

High Performance 2D Measurement System LINEAR HEIGHT

Bulletin No. 2104



World's best-in-class accuracy 2D measurement system

A sophisticated height gage offering exceptional accuracy of $(1.1+0.6L/600)\mu\text{m}^*$

(* L = measured height in mm)

Mitutoyo

Specifications

Type	LH600E	LH600EG
Order No.	518-351A-21	518-352A-21
Measuring range (Stroke)	0 - 972mm (600mm) 0 to 38" (24")	
Resolution	0.0001/0.001/0.01/0.1mm (selectable) .000001/.00001/.0001/.001" (selectable)	
Accuracy (at 20°C)	Indication accuracy*1	(1.1 + 0.6L/600)µm, L = Measured length (mm)
	Repeatability*1	Plane: 0.4µm (2σ), Hole: 0.9µm (2σ)
	Perpendicularity (forward and backward)*2	5µm (after compensation)
	Straightness (forward and backward)*2	4µm (mechanical accuracy)
Guiding method	Roller bearing	
Driving method	Motor-driven (5,10,15,20,25,30,40mm/s: 7 steps)/Manual	
Scale unit	Reflective-type linear encoder	
Measuring force	1N (automatic constant-force function)	
Balancing method	Counter weight balance	
Main unit moving mode	Full-floating(moving) / Semi-floating(measuring) air bearing	
Air source	Built-in compressor	
Monitor	5.7 inch COLOR TFT LCD (320 x 240 dots, with LED backlight)	
Max. number of programs	50	
Max. number of measured data	60,000 (Max. number of data is 30,000 / one program)	
Power supply	AC adapter / Battery (Ni-MH)	
Battery endurance	Operating*3	Approx. 5 hours (compressor duty cycle 25% max.)
	Standby*3	Approx. 10 hours
Battery charging time	Approx. 3 hours (usable during charge)	
Dimensions (WxDxH)	237x448x1013mm	247x448x1013mm
Mass	24kg	24.5kg
Operating temperature range	5 - 40°C / 20 - 80% RH (without condensation)	

*1 Guaranteed when using the standard eccentric φ5 probe.

*2 Guaranteed when using the Lever Head (MLH-521), Mu-Checker (M-511). Perpendicularity for horizontal direction is not defined. If the workpiece is cylindrical, measurement error may be observed.

*3 Optional large-capacity battery pack (12AAF675) for longer battery-powered operation (8 hours when operated and 16 hours on standby).

*4 Mitutoyo does not guarantee the operation of all commercial USB memories except for the following. Mitutoyo recommends those USB memories made by SanDisk Corporation or IO DATA DEVICE, INC. and that meet the following requirements.

- Those that are not compliant with USB3.0
- Those that have no security function such as encryption and fingerprint authentication
- Those that have no write-protect switch function

• It is recommended to use the Linear Height on a surface plate of high flatness accuracy.

Note: All information regarding our products, and in particular the illustrations, drawings, dimensional and performance data contained in this printed matter as well as other technical data are to be regarded as approximate average values. We therefore reserve the right to make changes to the corresponding designs. The stated standards, similar technical regulations, descriptions and illustrations of the products were valid at the time of printing. In addition, the latest applicable version of our General Trading Conditions will apply. Only quotations submitted by ourselves may be regarded as definitive.

Mitutoyo products are subject to US Export Administration Regulations (EAR). Re-export or relocation of Mitutoyo products may require prior approval by an appropriate governing authority.

Trademarks and Registrations

Designations used by companies to distinguish their products are often claimed as trademarks. In all instances where Mitutoyo America Corporation is aware of a claim, the product names appear in initial capital or all capital letters. The appropriate companies should be contacted for more complete trademark and registration information.

We reserve the right to change specifications and prices without notice.

Dimensions

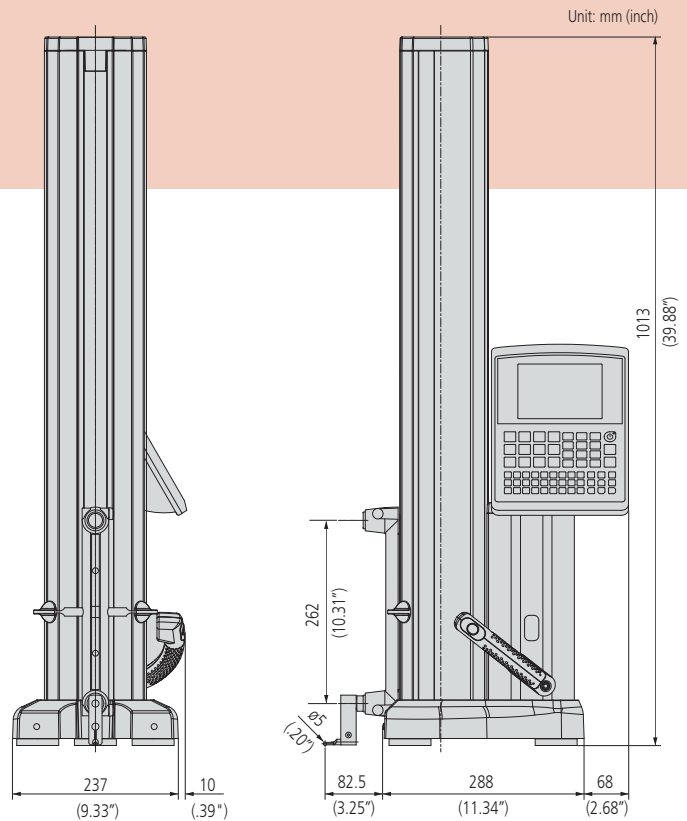

Standard accessories

- 5-step probe
- Ball-diameter corrected block
- Auxiliary weight (2pcs.)
- Battery pack
- AC adapter
- Power cable for AC adapter
- Clear cover
- Carrying handle
- Cap
- Hex wrench
- Manual set
- Inspection certificate

Coordinate Measuring Machines

Vision Measuring Systems

Form Measurement

Optical Measuring

Sensor Systems

Test Equipment and Seismometers

Digital Scale and DRO Systems

Small Tool Instruments and Data Management

Willrich Precision
Ph: 866-945-5742
email: sales@willrich.com

M³ Solution Centers

(Corporate Headquarters)
Westford, Massachusetts
Huntersville, North Carolina
Mason, Ohio
Plymouth, Michigan
City of Industry, California
Birmingham, Alabama

Mitutoyo
Precision is our Profession

World's Best Accuracy High Performance 2D

New Linear Height Series LH-600E/EG

*As of July 2012.

feature 1 World-class accuracy

- **Achieved accuracy: $(1.1 + 0.6L/600) \mu\text{m}$**

Best-in-class accuracy has been achieved by using a high-accuracy scale unit and high-accuracy guiding mechanism manufactured in our dedicated scale plant.

Displacement accuracy when measuring a height of 600mm: $1.7 \mu\text{m}$

feature 2 Superior ease of operation

- **Easy operation with a single touch of a key**

Each frequently-used measurement type is initiated by one dedicated icon-type command key.

Even a novice can immediately start measurement without instruction.

- **Color TFT LCD**

This has improved legibility and operability.

- **Unlimited USB memory**

Compatible models support more than 2 GB of USB memory.

- **High-accuracy air suspension assists measuring**

The Linear Height can move without friction over a surface plate using an air bearing incorporated in the base, powered by the small built-in compressor.

A semi-floating mode is also provided that allows measurement with the gage barely floating with no influence on the measuring accuracy.

This mode is effective in operations such as scanning measurement of a hole or shaft on a large workpiece and displacement measurements performed while moving the gage.

Additionally, the power grip model (518-352A-21 LH600EG) has improved handling operability.

feature 3 Numerous functions and options

- **Powerful measurement/calculation functions**

(See page 4 for details.)

Numerous types of measurement such as displacement/straightness/squareness are possible in addition to basic measurement functions including height and circle measurement.

This gage is also equipped with the 2D measurement function, tolerance judgment function, and others.

- **Standardization of measuring procedures**

Teaching the gage a series of measuring operations for a workpiece is possible (Repeat function). This function is very effective when measuring large batches of workpieces. Upon execution of the Repeat function, the probe automatically moves to the next measurement position (height). If an operation procedure manual is available, measurement can be standardized.

- **Supporting quality control with statistical processing functions**

GO/NG judgment is performed real-time on measured data. Up to 60,000 pieces of data can be stored in the database, on which can be performed various statistical calculations such as average, standard deviation and process capability. Quality control is also supported by graphic display of histograms.

- **Highly capable data processing unit**

The high-performance CPU supports future software upgrading.

Measurement results are output in CSV format, thus allowing users to reuse those results with their own software.

- **Versatile external interfaces**

A printer interface is provided, which is installed in the main unit to connect a thermal printer or Letter-size printer.

The USB interface allows a USB memory to back up and restore part programs and measured data that have been stored.

Moreover, the RS-232C interface can output measurement results to an external device such as a PLC.

- **Numerous optional probes**

This gage is provided with various types of probes and interchangeable styli flexibly compatible with complicated workpiece profiles and various measurement features.

Mitutoyo's lineup of options offers various interchangeable styli for $\phi 5$ ball probes, depth probes, dial indicator holders, etc.

The optional probes extend their flexibility with an M2/M3 threaded shank that allows various CMM styli to be attached.

Measurement System*



Reflective-type linear encoder & guide achieve world-class accuracy

Numerous accessories compatible with many types of workpiece and measurement features provided in addition to standard $\varnothing 5\text{mm}$ ball probes

High-accuracy air bearing that can be operated in semi-floating mode while making highly accurate measurements and fully floating mode for frictionless travel over a surface plate

Diverse interfaces

- Printer
- USB
- RS-232C
- Digimatic input

[Rear panel (connectors)]

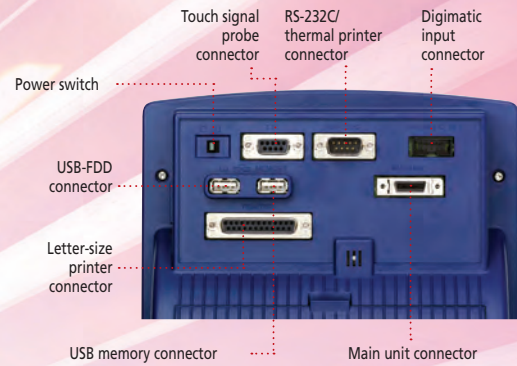

5.7 inch color TFT LCD display

Icon-type command keys provide simple one-touch operation to drive powerful functionality

A complete cordless system with a built-in compressor and battery, allowing frictionless movement on a surface plate

Functions

The touch of a single key automatically runs the instrument until the last result is displayed. This eliminates the need to execute key operations at each step in the measurement process, allowing you to concentrate 100% on workpiece inspection.

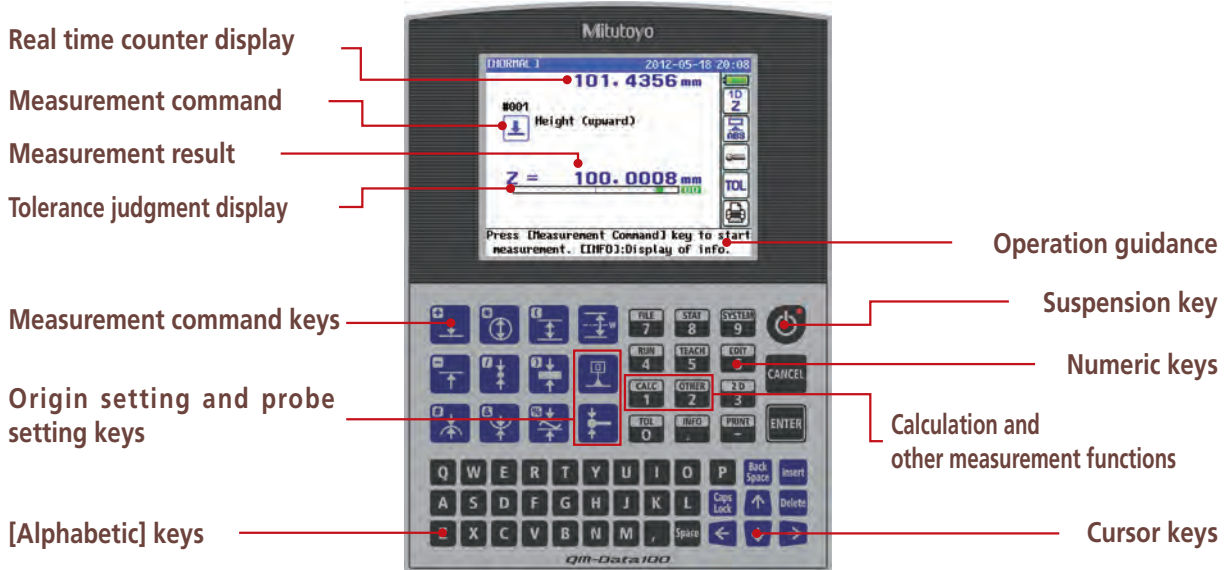

Single-touch Basic functions

	Measures the height of an upward-facing surface.		Measures the diameter and center of a hole.		Measures the width and center of an inner diameter.		Measures the width and center position between two elements.
	Measures the height of a downward-facing surface.		Measures the diameter and center of a shaft.		Measures the width and center of an outer diameter.		Sets the ABS origin (absolute reference origin) or INC origin (incremental origin defined by the user), switches between ABS/INC origins and sets the offset ABS origin.
	Measures the maximum height of a downward or upward-facing surface.		Measures the minimum height of a downward or upward-facing surface.		Measures the difference between maximum height and minimum height of an upward or downward facing surface.		Sets the probe type, measures the probe diameter, inputs the probe diameter, saves the probe, loads the probe and shifts the probe position.
	Performs calculation, including angle.		Displays a comment when operations are paused, measures the position of a hole with a tapered probe, inputs measurement from a Digimatic measuring instrument and measures perpendicularity.		Suspends or resumes system operation.		

Other functions

2D measurement	2D origin setting, XY axis setting, Element recall, Polar coordinate recall, Coordinate distance calculation, 2D distance calculation, 2 elements intersection-angle calculation, 3 elements intersection-angle calculation, Pitch-circle calculation
Tolerance judgment function	Tolerance/nominal value setting, Tolerance judgment result output, Warning functions
User-support functions	Switching resolution, Power saving function, Switchable measurement speed, Semi-floating measurement
Part-program functions	Creating/editing/executing a part program
Statistical processing functions	Basic statistical processing, Histogram
Accuracy-compensation functions	Temperature compensation, Scale factor

Screen display examples

The measurement operation is supported with graphics on the large LCD.

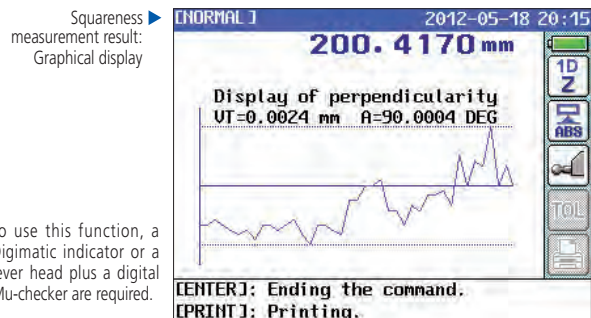
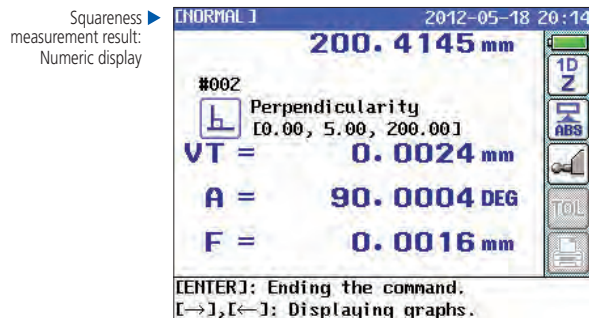
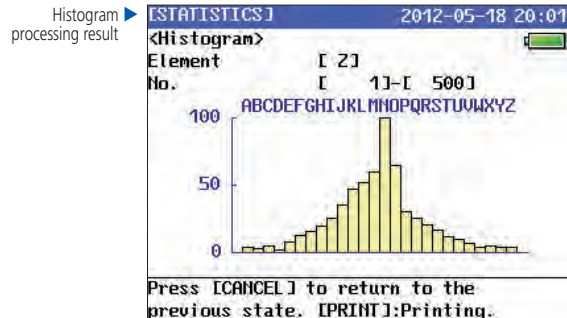
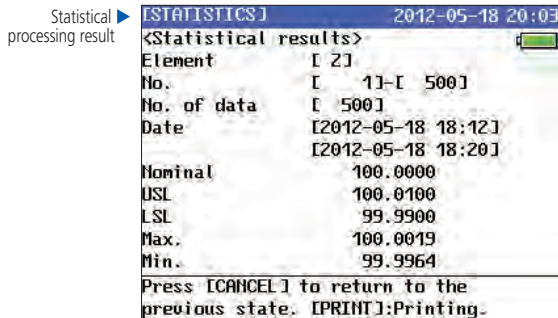

To use this function, a Digimatic indicator or a lever head plus a digital Mu-checker are required.

Printer output examples

A thermal printer that can be attached to the Linear Height main unit is available as an optional accessory.

Result data can also be output to a commercial letter-size printer.

Thermal printer output

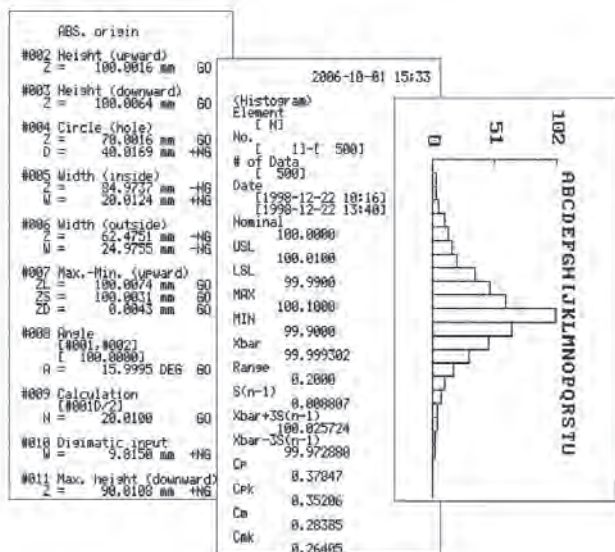

Letter size printer output

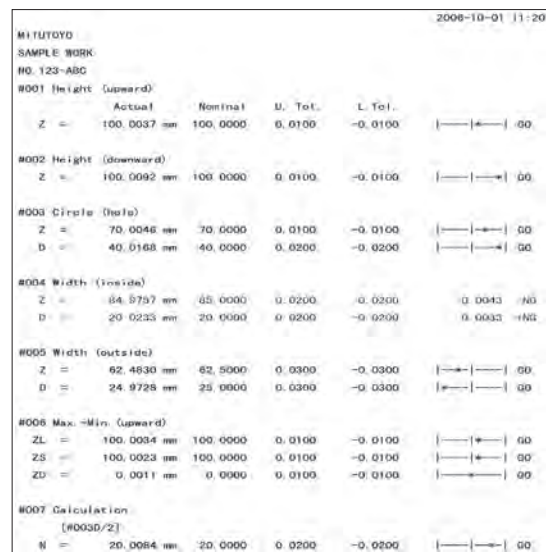

Frequently used measurements

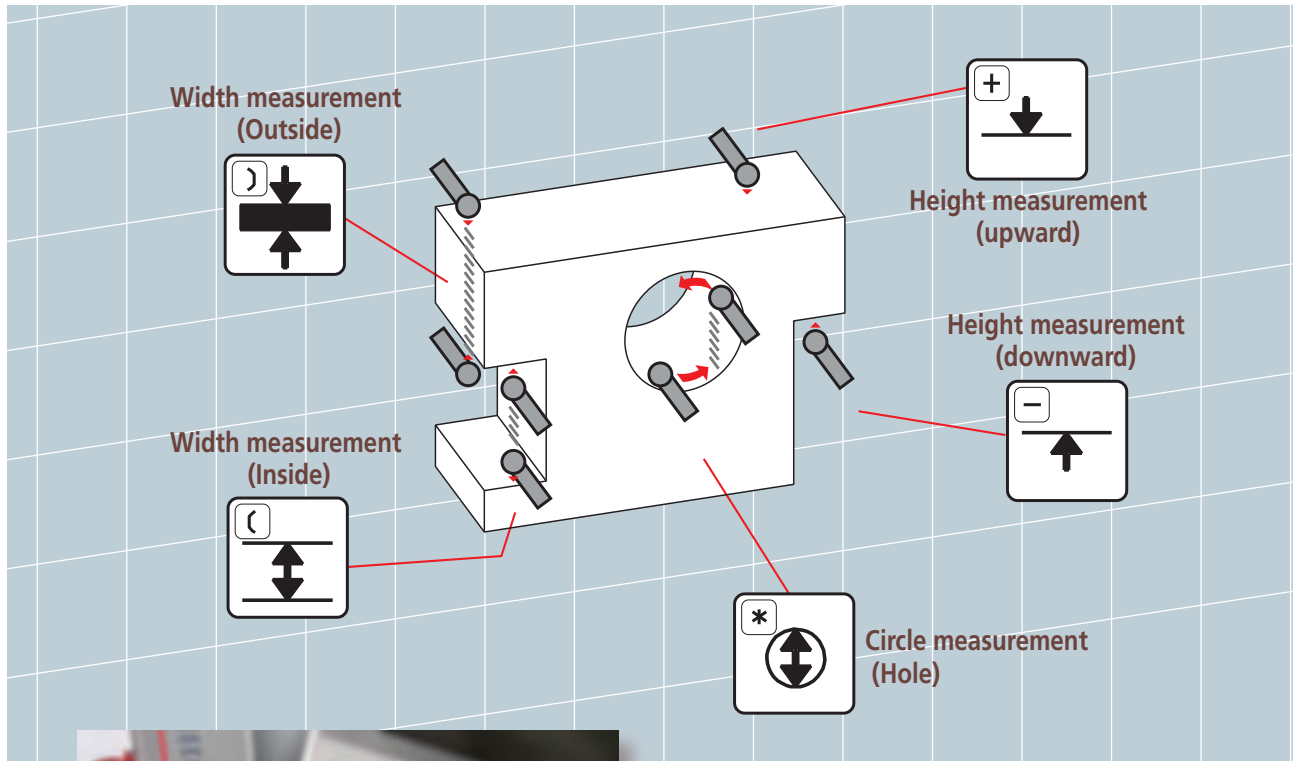

The Power Grip Type EG makes it easy to approach the workpiece.

Optional Accessories

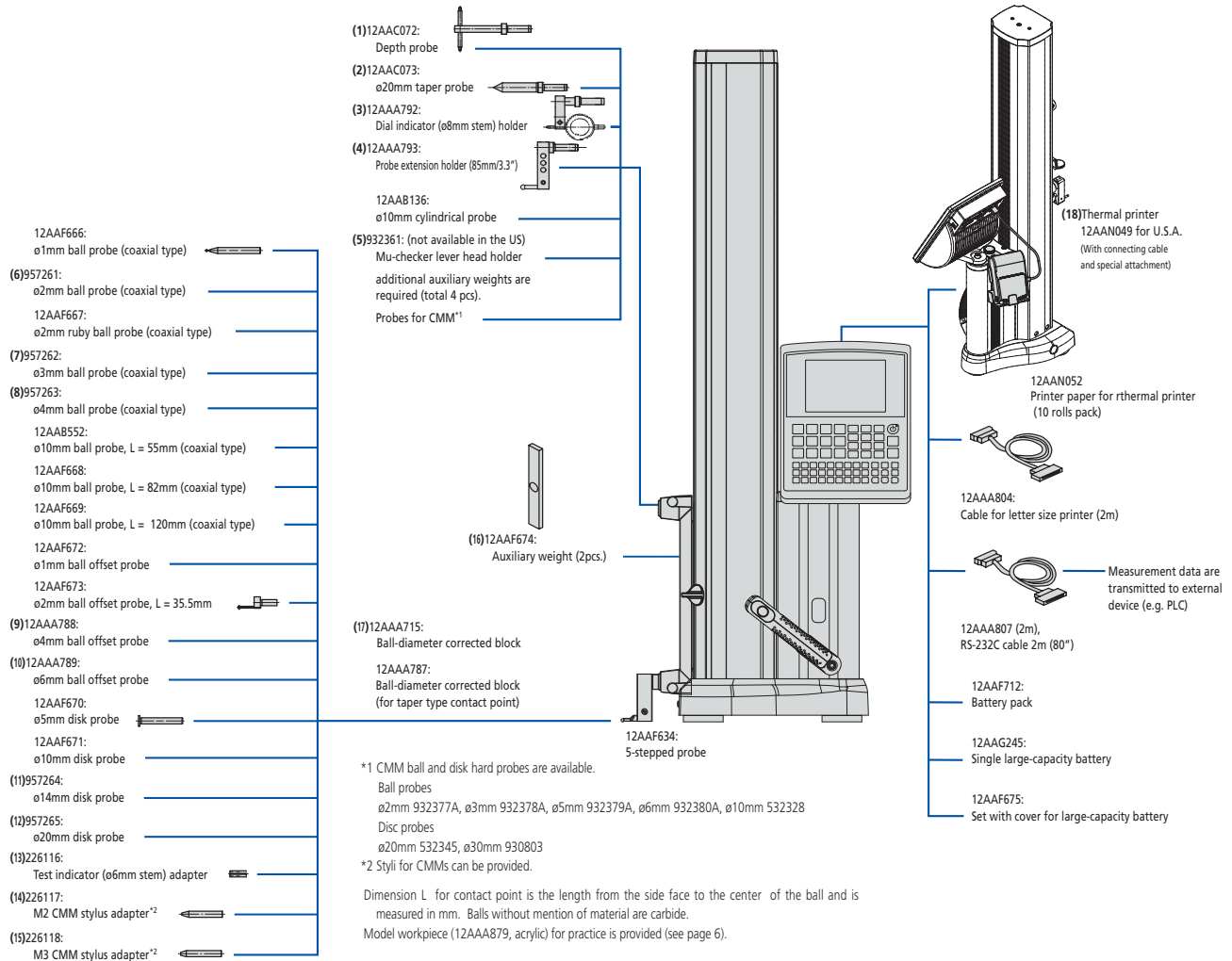

Many kinds of optional probes enable many types of measurement



A choice of peripherals expand functionality



(18) Thermal printer