

Vernier Calipers MarCal 16 N, 16 FN, 16 GN, 16 DN with scale reading

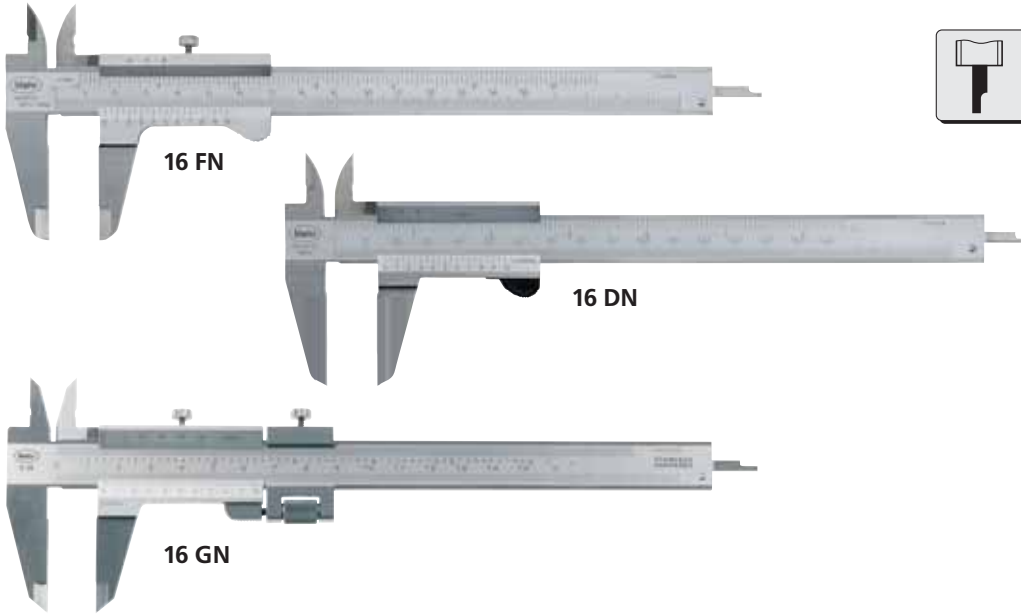

- ### Features
- Vernier and main scale have a satin chrome finish for glare free reading
 - Slide and beam made of hardened stainless steel
 - Raised guide ways for the protection of the scale
 - Measuring blades for inside measurement
 - Step measuring function
 - Depth bar
 - Locking screw or thumb clamp
- Supplied with:
 Plastic case and thread table

Technical Data

	Measuring range		Readings		Error limit G	DIN 862	Order no. without fine adjustment	Order no. with fine adjustment	Remarks
	mm	(inch)	upper inch	lower mm					
16 FN	150			0.05	0.05	•	4100420		Locking screw above
16 FN	150	(6")	1/128"	0.05	0.05	•	4100400		Locking screw above
16 DN	150	(6")	1/128"	0.05	0.05	•	4100600		Thumb clamp
16 N	150	(6")	1/128"	0.05	0.05	•	4100500		Locking screw below
16 GN	150			0.02	0.04		4100650	4100660*	}
16 GN	150	(6")	.001"	0.02	0.04		4100670	4100680*	
16 FN	200			0.05	0.05	•	4100421		}
16 FN	200	(8")	1/128"	0.05	0.05	•	4100401		
16 GN	200			0.02	0.05		4100651	4100661*	
16 GN	200	(8")	.001"	0.02	0.05		4100671	4100681*	
16 FN	300			0.05	0.05	•	4100422		}
16 FN	300	(12")	1/128"	0.05	0.05	•	4100402		
16 GN	300			0.02	0.05		4100652	4100662*	
16 GN	300	(12")	.001"	0.02	0.05		4100672	4100682*	

* Calipers with fine adjustment the measuring range is shortened by 20 mm / 1"

Dimensions mm	a	b	c	d	e	f
150	10	40	16	228	16 x 3	3.8
200	14	50	19	290	17 x 3.5	3.8
300	16	64	23	404	20 x 4	4.8

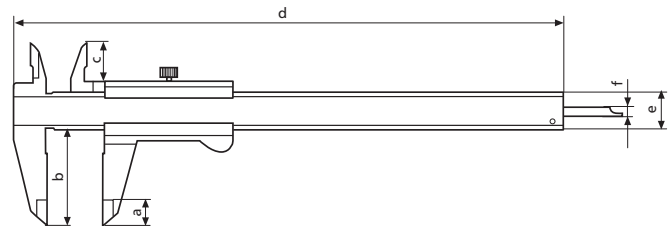

Accessories

	Order no.
Depth Measuring Bridge	16 Em 4102020
Leather case for meas. range 150 mm	4100302

