

# Vernier Caliper

## SERIES 160 — with Nib Style Jaws and Fine Adjustment

### FEATURES

- The jaws have round measuring faces for accurate ID measurement.
- With fine adjustment carriage to feed the slider finely.
- Inside and outside measurements can be directly read from the upper and lower slider graduations, respectively.
- Supplied with vinyl holster in fitted carton. Except 12" / 300mm, 18" / 450mm and 24" / 600mm are fitted carton only. Over 24" / 600mm supplied in wooden case.



### Technical Data

Accuracy: Refer to the list of specifications.  
Graduation: Refer to the list of specifications.

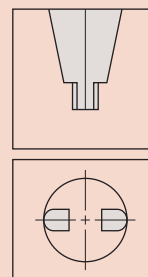

Round surface of jaws for accurate ID measurement

### DIMENSIONS

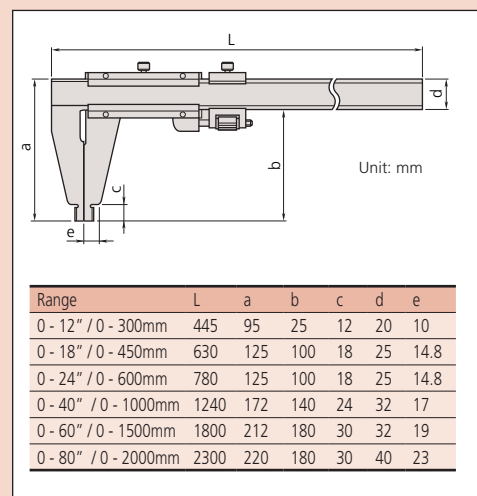

**Inch** with inch/inch dual scale

Range*	Order No.	Accuracy	Graduation		Mass (g)
			Lower Scale	Upper Scale	
0 (.3") - 12"	<b>160-124</b>	±.0015"	.001"	.001"	450
0 (.5") - 18"	<b>160-116</b>	±.002"	.001"	.001"	1,200
0 (.5") - 24"	<b>160-102</b>	±.002"	.001"	.001"	1,400
0 (1") - 40"	<b>160-105</b>	±.003"	.001"	.001"	3,500
0 (1") - 60"	<b>160-111</b>	±.004"	.001"	.001"	4,850
0 (1") - 80"	<b>160-114</b>	±.005"	.001"	.001"	10,200

\*( ) : Minimum dimension in ID measurement