

TP20 touch-trigger probe and MCR20 module change rack

- Detachable stylus modules, available in four trigger force options, provide fast stylus changing without the need for requalification
- Direct replacement for the Renishaw TP2 touch-trigger probe
- MCR20 module change rack provides automatic stylus changing using simple move commands (optional)
- Simple to retrofit
- Direct mounting on all Renishaw probe heads incorporating a standard M8 probe connector
- Mounting to Renishaw autojoint probe heads using PAA adaptors / extensions
- Compatibility with existing probe interfaces
- Design based on the industry-proven TP2 touch-trigger probe

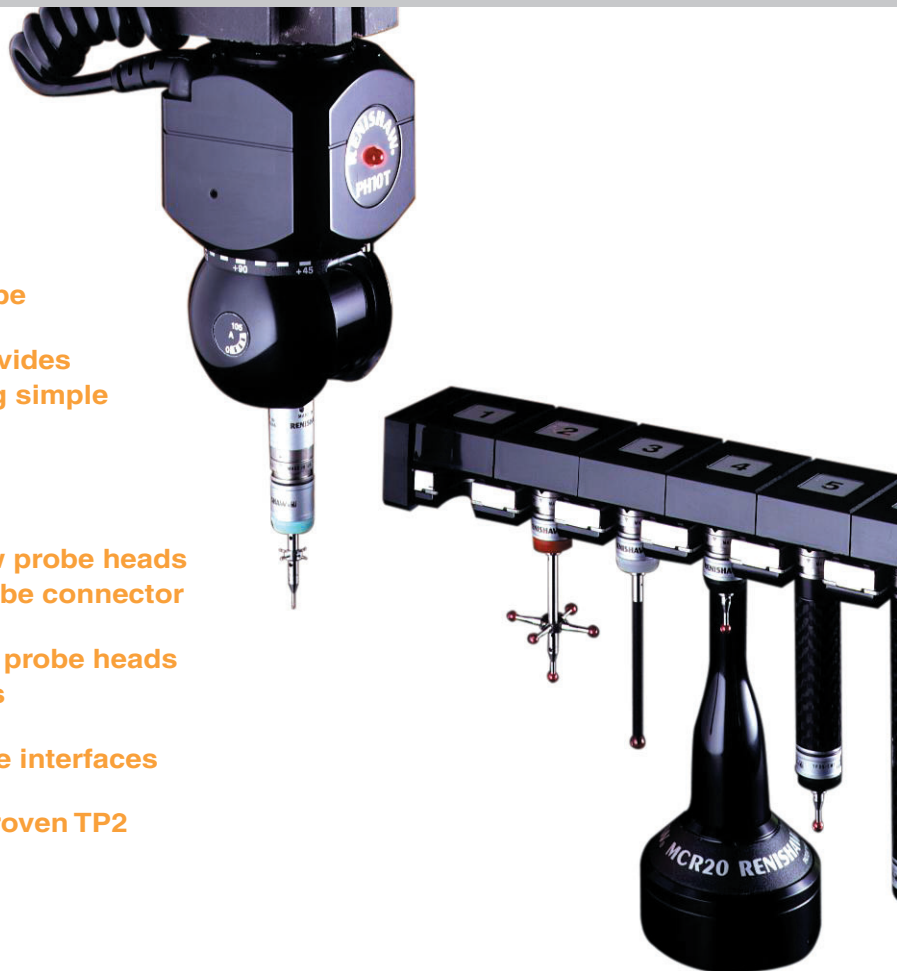

TP20 modular probes

The TP20 is available as either a 5-way or 6-way kinematic touch-trigger probe. Its two piece design comprises a probe body and detachable stylus module(s), giving the ability to change stylus configurations either manually or automatically without re-qualification of the stylus tips, and provides significant time savings in inspection routines.

A direct replacement for the industry standard Renishaw TP2 probe, the TP20 probe system brings a range of new benefits to manual and DCC CMM applications, and can easily be retrofitted to existing TP2 installations.

The TP20 can be used on a wide range of Renishaw's manual or motorised probe heads, either by direct mounting using the standard M8 thread or, alternatively, by using a PAA adaptor to connect to an autojoint.

The system components comprise:

- TP20/TP20 NI probe body
- TP20 stylus module – seven module variants allow for optimisation of performance to suit the application
- MCR20 module changing rack - automatic operation
- The TP20 probe system may be used with Renishaw's PI 4-2, PI 7-2 or PI 200 probe interfaces

TP20 probe body

The TP20 probe body houses one half of the highly repeatable magnetic kinematic coupling that attaches the stylus module and body. The body also contains a magnetic proximity switch to inhibit triggering of the probe during automatic module changing with MCR20.

Note: If the probe is operated close to magnetised parts/clamping etc., the probe trigger may become inhibited. Countermeasures include the use of long styli, stylus extensions or body orientation to increase the distance to the magnetic source. Alternatively, use the TP20 NI probe body.

TP20 NI probe body

The TP20 NI probe differs from the TP20 body in that it is not affected by magnetic fields. However, the probe trigger must be inhibited through software during change cycles using the MCR20.

TP20 stylus module

The TP20 stylus module houses the touch-trigger probe mechanism, carries the stylus assembly and provides overtravel in $\pm X$, $\pm Y$ and $\pm Z$ axes (or $\pm Z$ in the case of TP20 6-way module). The stylus mounting thread accepts styli from the Renishaw M2 range.

A range of seven, application specific, stylus modules are available, being identified by coloured caps:

- **LF** - Low force stylus module (green cap)
- **SF** - Standard force stylus module (black cap)
- **MF** - Medium force stylus module (grey cap)
- **EF** - Extended force stylus module (brown cap)
- **6W** - 6-way stylus module (blue cap)
- **EM1 SF** - Standard force extension module
- **EM2 SF** - Standard force extension module

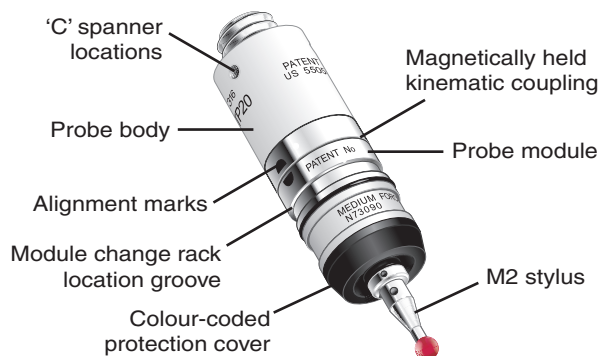
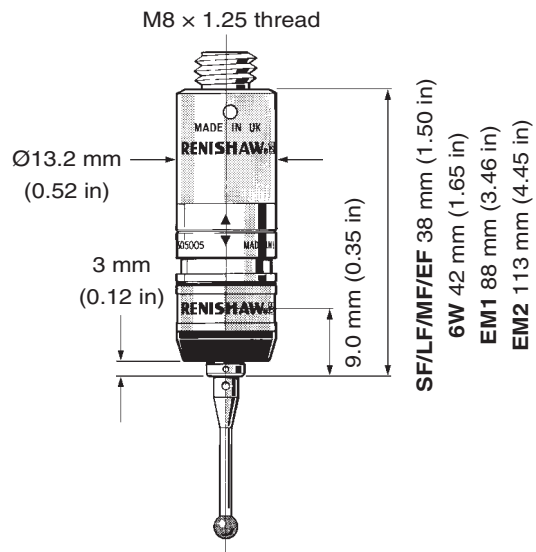

Figure 1 - The TP20 touch-trigger probe

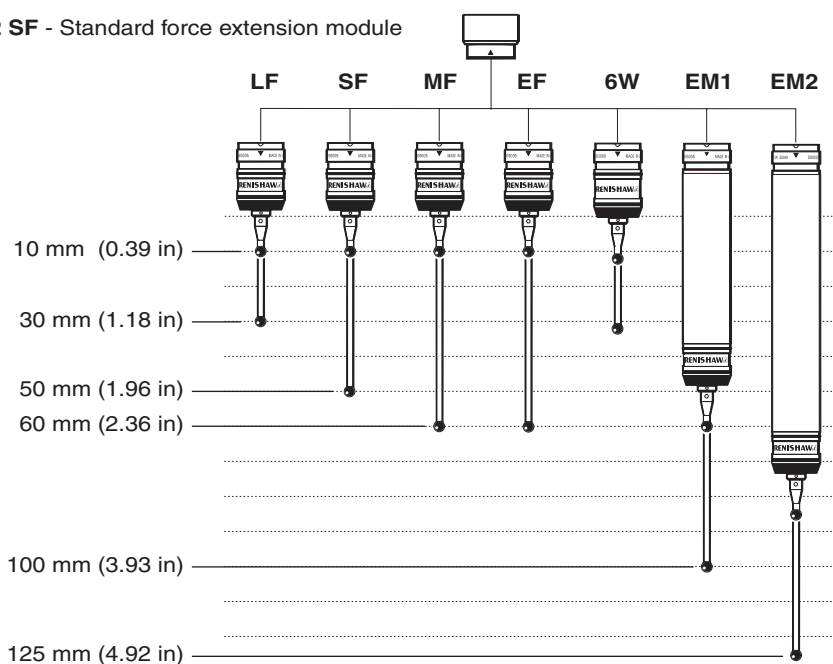

Figure 2 - Stylus module comparison

The MCR20 module changing rack

The MCR20 is designed to securely store stylus modules ready for rapid automatic changing, whilst protecting mating surfaces from any airborne contaminants within the working envelope.

Only seven datum points are needed to set the MCR20 alignment and probe module changing co-ordinates.

By generating a magnetic field about the front of each docking port lid, the MCR20 effectively ‘closes’ the probe’s inhibit switch during a probe module changing cycle. Rack function is completely passive and no electrical input is required.

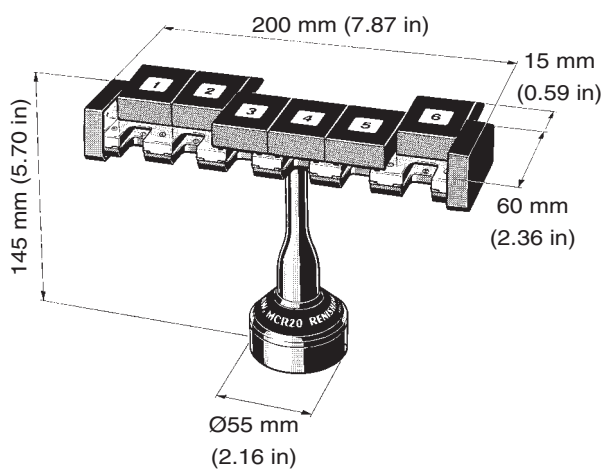

Figure 3 - The MCR20 module change rack

During automatic changing of probe modules, limited crash protection is provided by hinged overtravel mechanisms incorporated within both the base and the docking port assembly of the MCR20. Provided any collision occurs in the direction of overtravel, the hinged overtravel mechanisms can be manually reset and it should not normally be necessary to re-datum the rack.

MCR20 technical specification

NOTE: For further information on the MCR20, refer to the TP20 system installation and user’s guide (Renishaw part number H-1000-5008), available through your supplier.

Dimensions	Length	200 mm (7.87 in)
	Width	60 mm (2.36 in)
	Height	145 mm (5.70 in)
Port entry velocity		Maximum 800 mm/s
Mounting orientation		Unrestricted
Y axis overtravel		Hinged breakout from base 55 mm (2.16 in) travel at port height
Z axis overtravel		Hinged docking port assembly 90° travel in -Z axis
Inhibit range		50 mm (1.97 in) from port centre

TP20 probe technical data

NOTE: For further information on the TP20 probe, refer to the TP20 system installation and user’s guide (Renishaw part number H-1000-5008), available through your supplier.

NOTE: The following data is derived from high accuracy test rig measurements and may not represent the performance achievable on a CMM. Please consult you CMM supplier for overall system accuracy information.

Performance at 10 mm stylus length

Parameter	Probe module type						
	LF	SF	MF	EF	6W	EM1 STD	EM2 STD
Unidirectional repeatability* (2σ)	0.35 μm	0.35 μm	0.50 μm	0.65 μm	0.8 μm	0.35 μm	0.35 μm
2D (XY) form measurement deviation*	±0.6 μm	±0.8 μm	±1.00 μm	±2.00 μm	±1.5 μm	±0.8 μm	±0.8 μm

* Measured at trigger speed of 8 mm/s.

Test stylus ball Ø4 mm.

TP20 probe technical data (continued)

Probing forces and overtravel limits

Probe module type and stylus length	Trigger force (nominal at stylus tip)		Overtravel force (maximum at stylus tip)			Overtravel displacement		
	XY	Z	XY	+Z	-Z	XY **	+Z	-Z
LF 10 mm	0.055 N (5.5 gf)	0.65 N (65 gf)	0.09 N (9 gf)	1.15 N (115 gf)	-	±14°	3.1 mm	-
SF 10 mm	0.08 N (8 gf)	0.75 N (5 gf)	0.2-0.3 N (20-30 gf)	3.5 N (350 gf)	-	±14°	4.0 mm	-
MF 25 mm	0.1 N (10 gf)	1.9 N (190 gf)	0.2-0.4 N (20-40 gf)	7.0 N (700 gf)	-	±14°	3.7 mm	-
EF 50 mm	0.1 N (10 gf)	3.2 N (320 gf)	0.2-0.5 N (20-50 gf)	10.0 N (1 kgf)	-	±14°	2.4 mm	-
6W 10 mm	0.14 N (14 gf)	1.6 N (160 gf)	0.25 N (25 gf)	2.5 N (250 gf)	9.0 N (900 gf)	±14°	4.5 mm	1.5 mm
EM1 10 mm	0.08 N (8 gf)	0.75 N (75 gf)	0.2-0.3 N (20-30 gf)	3.5 N (350 gf)	-	±14°	4.0 mm	-
EM2 10 mm	0.08 N (8 gf)	0.75 N (75 gf)	0.2-0.3 N (20-30 gf)	3.5 N (350 gf)	-	±14°	4.0 mm	-

** The module may detach if this value is exceeded.

NOTE: The trigger force setting of the standard force probe module is the same as that of the TP2 probe when set at its factory setting.

Technical specification

Product compatibility	The TP20 is suitable for use with all probe interfaces and probe heads which service the TP1, TP2, TP6, TP7 and TP200 touch-trigger probes. The TP20 is compatible with the PEL, PAA and PEM series of probe extensions / adaptors.						
Probe characteristics	LF	SF	MF	EF	6W	EM1 STD	EM2 STD
Length	38 mm	38 mm	38 mm	38 mm	42 mm	88 mm	113 mm
Diameter	13.2 mm	13.2 mm	13.2 mm	13.2 mm	13.2 mm	13.2 mm	13.2 mm
Weight *	22 g	22 g	22 g	22 g	25 g	28 g	30 g
Sense directions	5-way †	5-way †	5-way †	5-way †	6-way ††	5-way †	5-way †
Mount	Probe: M8 × 1.25 × 5 mm			Stylus: M2 × 0.4			
Module pull-off force	1 kgf maximum						
Sealing	IP30						
Cable length	50 m (24 awg / 0.2 mm ² conductors)						
Probe module change life	>25,000 changes						
Probe module change repeatability	Automatic (2σ): 1.0 μm			Manual (2σ): 2.0 μm			
Inhibit system	Magnetic proximity switch in probe body						
Inhibit sensitivity	>500 Gauss (50 mT)						
Inhibit range	Up to 50 mm from the docking port						

* Body and module

† 5-way = ±X, ±Y, Z

†† 6-way = ±X, ±Y, ±Z

NOTE: The TP20 probe uses a magnetically actuated inhibit system. The TP20 will be automatically inhibited from triggering when it approaches the front of the MCR20 module change rack. The TP20 NI may be more appropriate for gauging magnetised parts, or parts held in magnetic fixtures.