

RMP600 radio machine probe



Specification

Principal application		Workpiece inspection and job set-up on multi-tasking machines, machining centres and gantry machining centres.
Transmission type		Frequency hopping spread spectrum (FHSS) radio Radio frequency 2400 MHz to 2483.5 MHz.
Radio approval regions		China, Europe (all countries within the European Union), Japan and USA. For details about other regions, please contact Renishaw.
Compatible interfaces		RMI and RMI-Q
Operating range		Up to 15 m (49.2 ft)
Recommended styli		High modulus carbon fibre, lengths 50 mm (1.97 in) to 200 mm (7.88 in)
Weight without shank (including batteries)		1010 g (35.63 oz)
Switch-on/switch-off options		Radio on → Radio off or timer off Spin on → Spin off or timer off Shank switch on → Shank switch off
Battery life (2 × AA 3.6 V lithium-thionyl chloride)	Standby life	1300 days maximum, dependent on switch-on/switch-off option.
	Continuous use	230 hours maximum, dependent on switch-on/switch-off option.
Sense directions		±X, ±Y, +Z
Unidirectional repeatability		0.25 µm (10 µin) 2σ – 50 mm (1.97 in) stylus length (<i>see note 1</i>) 0.35 µm (14 µin) 2σ – 100 mm (3.94 in) stylus length
2D lobing in X, Y		±0.25 µm (10 µin) – 50 mm (1.97 in) stylus length (<i>see note 1</i>) ±0.25 µm (10 µin) – 100 mm (3.94 in) stylus length
3D lobing in X, Y, Z		±1.00 µm (40 µin) – 50 mm (1.97 in) stylus length (<i>see note 1</i>) ±1.75 µm (70 µin) – 100 mm (3.94 in) stylus length
Stylus trigger force (<i>see notes 2 and 5</i>)		
XY plane (typical minimum)		0.20 N, 20 gf (0.72 ozf)
+Z direction (typical minimum)		1.90 N, 194 gf (6.83 ozf)
Stylus overtravel force		
XY plane (typical minimum)		2.80 N, 286 gf (10.07 ozf) (<i>see note 3</i>)
+Z direction (typical minimum)		9.80 N, 999 gf (35.25 ozf) (<i>see note 4</i>)
Minimum probing speed		3 mm/min (0.12 in/min) with auto-reset
Sealing		IPX8 (EN/IEC 60529)
Operating temperature		+5 °C to +50 °C (+41 °F to +122 °F)

- Note 1 Performance specification is tested at a standard test velocity of 240 mm/min (9.45 in/min). Significantly higher velocity is possible depending on application requirements.
- Note 2 Trigger force, which is critical in some applications, is the force exerted on the component by the stylus when the probe triggers. The maximum force applied will occur after the trigger point (overtravel). The force value depends on related variables including measuring speed and machine deceleration. **RENCAGE™** equipped probes offer ultra low trigger forces.
- Note 3 Stylus overtravel force in XY plane occurs 80 µm after the trigger point and rises by 0.35 N/mm, 36 gf/mm (32 ozf/in) until the machine tool stops (in the high force direction and using a carbon fibre stylus).
- Note 4 Stylus overtravel force in +Z direction occurs 7 µm to 8 µm after the trigger point and rises by 1.5 N/mm, 153 gf/mm (137 ozf/in) until the machine tool stops.
- Note 5 These are the factory settings, manual adjustment is not possible.

RMP600 dimensions

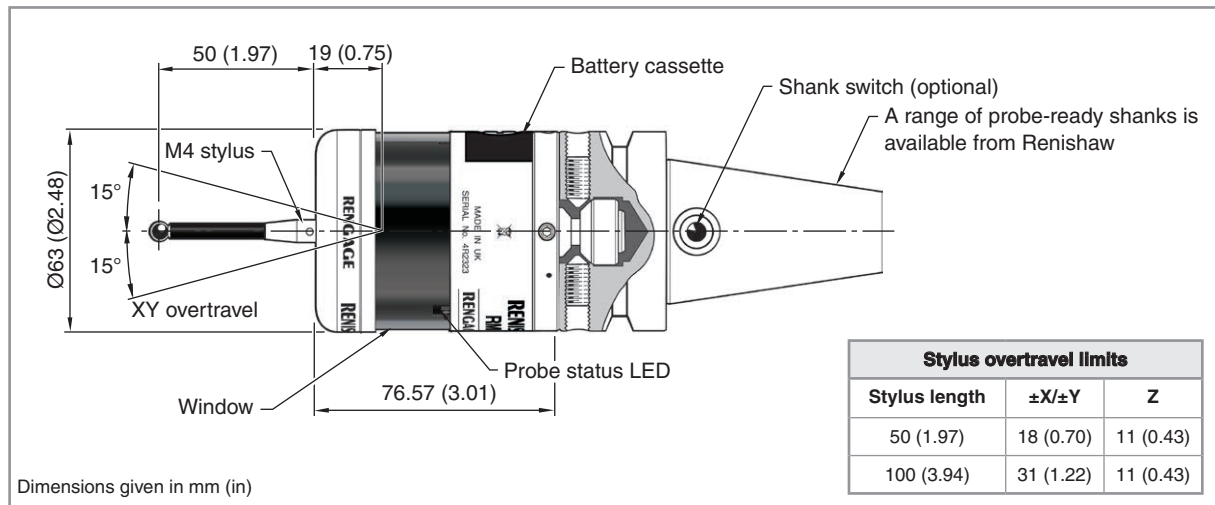

Performance envelope

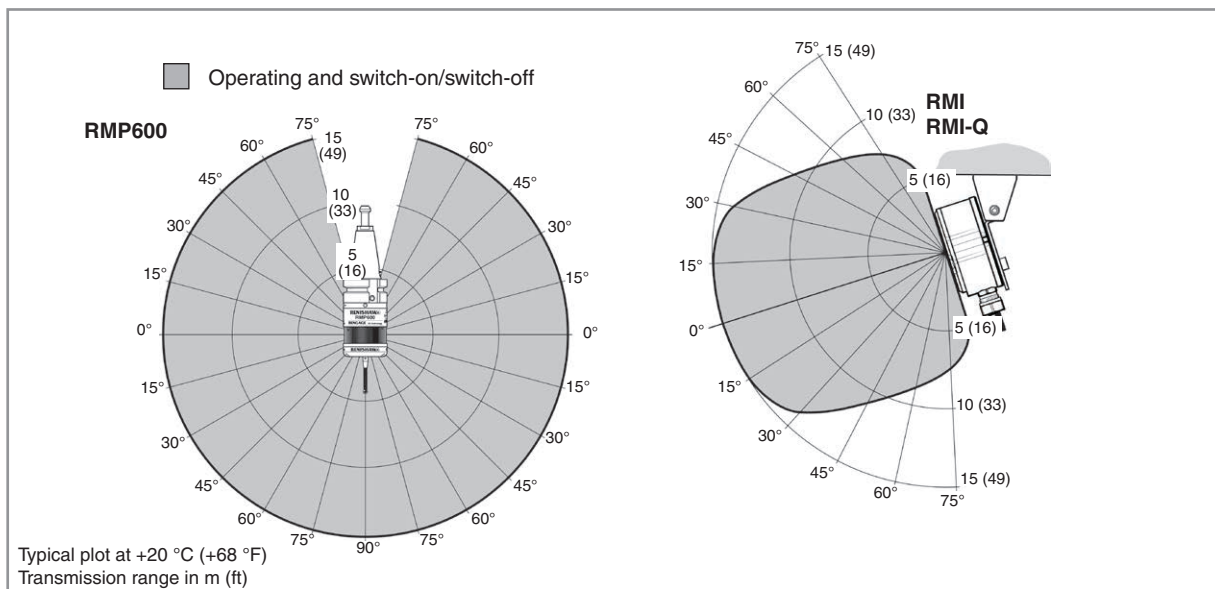

Spare parts and accessories

A full range of spare parts and accessories is available.
 Please contact Renishaw for a full list.

