

Vernier Caliper MarCal 18 N

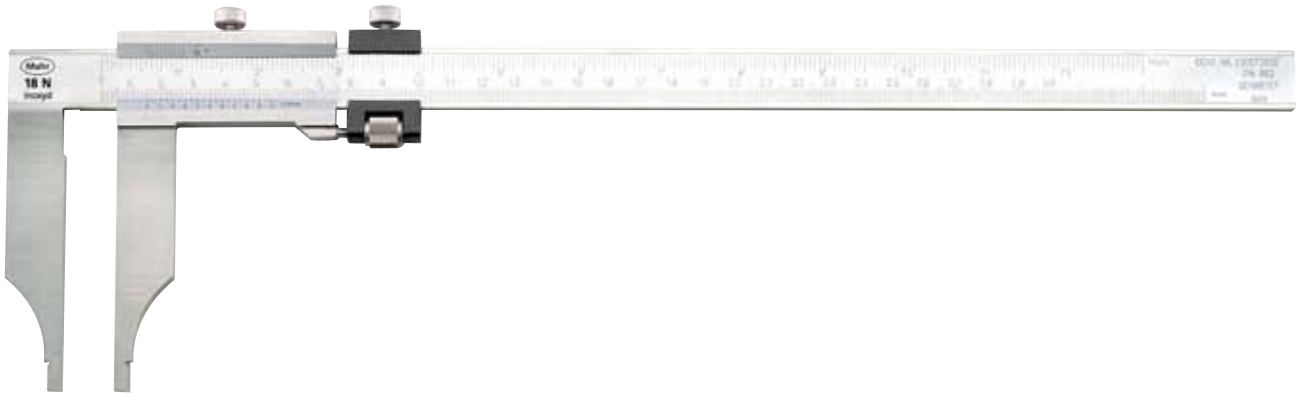

Features

- Vernier and main scale have a satin chrome finish for glare free reading
- Slide and beam made of hardened stainless steel
- Raised guide ways for the protection of the scale
- Rounded measuring faces for inside measurement
- Locking screw
- Supplied with: up to 1000 mm delivered with a case, over 1000 mm individually packed

Technical Data

Measuring range		Resolution		Error limit G		Order no.	Order no.
mm	(inch)	upper	lower	mm		without fine adjustment	with fine adjustment
200		0.02 mm	0.02 mm	0.05		4112200	
300		0.02 mm	0.02 mm	0.05		4112201	4112220
300	(12")	.001"	0.02 mm	0.05			4112230
500		0.02 mm	0.02 mm	0.06			4112221
500	(20")	.001"	0.02 mm	0.06			4112231
500		0.05 mm	0.05 mm	0.07	●	4112210	
800		0.02 mm	0.02 mm	0.08			4112222
800	(32")	.001"	0.02 mm	0.08			4112232
800		0.05 mm	0.05 mm	0.10	●	4112211	
1000		0.02 mm	0.02 mm	0.08			4112223
1000	(40")	.001"	0.02 mm	0.08			4112233
1000		0.05 mm	0.05 mm	0.12	●	4112212	
1500		0.02 mm	0.02 mm	0.10			4112224
1500	(60")	.001"	0.02 mm	0.10			4112234
1500		0.05 mm	0.05 mm	0.18	●	4112213	
2000		0.02 mm	0.02 mm	0.12			4112225
2000	(80")	.001"	0.02 mm	0.12			4112235
2000		0.05 mm	0.05 mm	0.22	●	4112214	

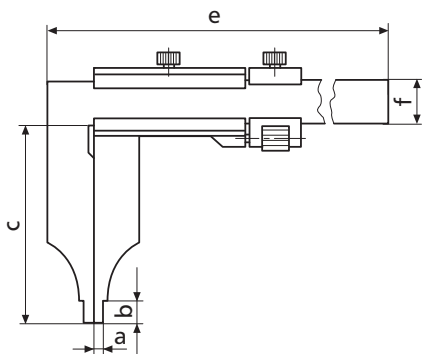

Dimensions

mm		a	b	c	e	f
18 N	200 mm	5	10	80	310	20 x 5
	300 mm	5	10	90	410	20 x 5
	500 mm	10	19	150	675	25 x 6
	800 mm	10	19	150	985	30 x 7
	1000 mm	10	19	150	1185	30 x 7
	1500 mm	15	19	200	1760	40 x 8
	2000 mm	15	19	200	2270	45 x 10