

# SPECIAL OFFER!

# TWIN-CAL IP67

Willrich Precision  
Ph:866-945-5742  
sales@willrich.com



## Features:

- Highest IP67 standard protection against liquids and dust, also with cable connection
- Biggest LCD screen ever with 11 mm digits
- More than 12 000 hours autonomy
- ABS measuring mode
- Unique TWIN & LINK connectivity concept, plus evolutive output capability with all TWIN-CAL
- Soft touch feature for smooth measurements
- Stainless steel plate cover with PVD deposit for optimal protection

## Electronic Calipers

- 150 mm / 6 in
- 200 mm / 8 in
- 300 mm / 12 in



Patent pending

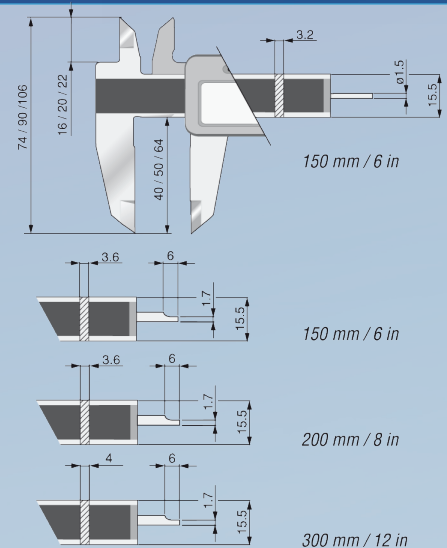
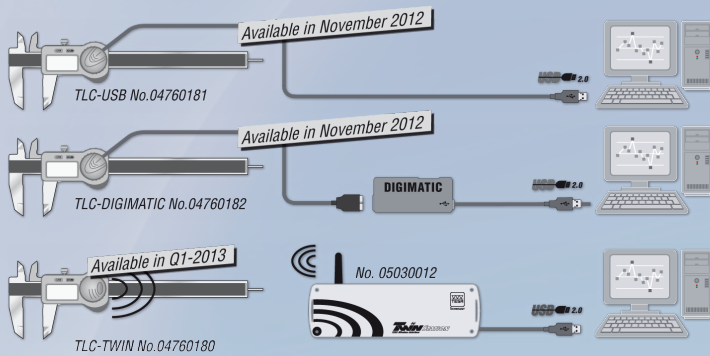

## Technical specifications

Order number	Measuring range	Depth Rod	Thumb wheel
00590302	150 mm / 6 in	•	•
00590303	150 mm / 6 in	■	•
00590304	200 mm / 8 in	■	•
00590305	300 mm / 12 in	■	•
Accessories		■	•
01961000	Lithium battery 3V, type CR 2032		
00560013	Depth measuring foot (150 mm / 6 in)		
00560106	Thumb wheel for caliper (150 mm / 6 in)		
058101	Battery cover for IP67 model		
04981001	DATA-Direct		
04981002	STAT-Express		
S47120003	USB multiplexer, 7x ports USB 2.0		

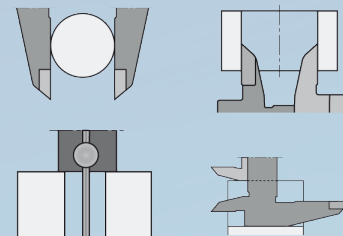

For more information contact:

WILLRICH PRECISION 866-945-5742 /  
SALES@WILLRICH.COM