

MEASURING MICROSCOPES MF C/MF-U C SERIES

PRE1303(4)



Higher performance measuring microscopes stretch
the boundaries

Mitutoyo

High Precision Measuring and Optimal Image Quality



MF C / MF-U C SERIES

Expectations of measuring microscope performance

A measuring microscope is a versatile instrument featuring highly accurate linear measurement as well as observation functions. This combination enables detailed inspection of products such as semiconductors, electrical and electronic parts, precision automobile components, plastic moldings, tools, and medical goods. Delicate workpieces that would be deformed by contact measurement and workpieces with details too small to be traced by a contact probe can be easily measured.

The essential element of a measuring microscope is an optimum balance of optical performance, accuracy and ease of operation. Objects that were previously invisible, or only barely visible, can now not only be observed but also measured. We believe that customer expectations of measuring microscope performance will keep on growing, and this must be matched by ease of use, high measurement throughput and environmental friendliness. Mitutoyo will continue to deliver high-quality and high-definition measuring microscopes while maintaining our commitments and beliefs in order to fulfill our responsibility to support fundamental industrial technologies.



In-house design

Mitutoyo designs all measuring microscope main units, optical systems (including lenses), and the digital scales that are essential for accuracy.

This approach enables a level of support that otherwise would be impossible, and puts us in a position to speedily comply with our customers' specific requests as far as practicable.



Concept design, manufacturing, and evaluation of microscope main units and components

Development design, manufacturing, and evaluation of optical systems and lenses

Development, manufacturing, and evaluation of high accuracy digital scales

Top-level Measuring and Viewing

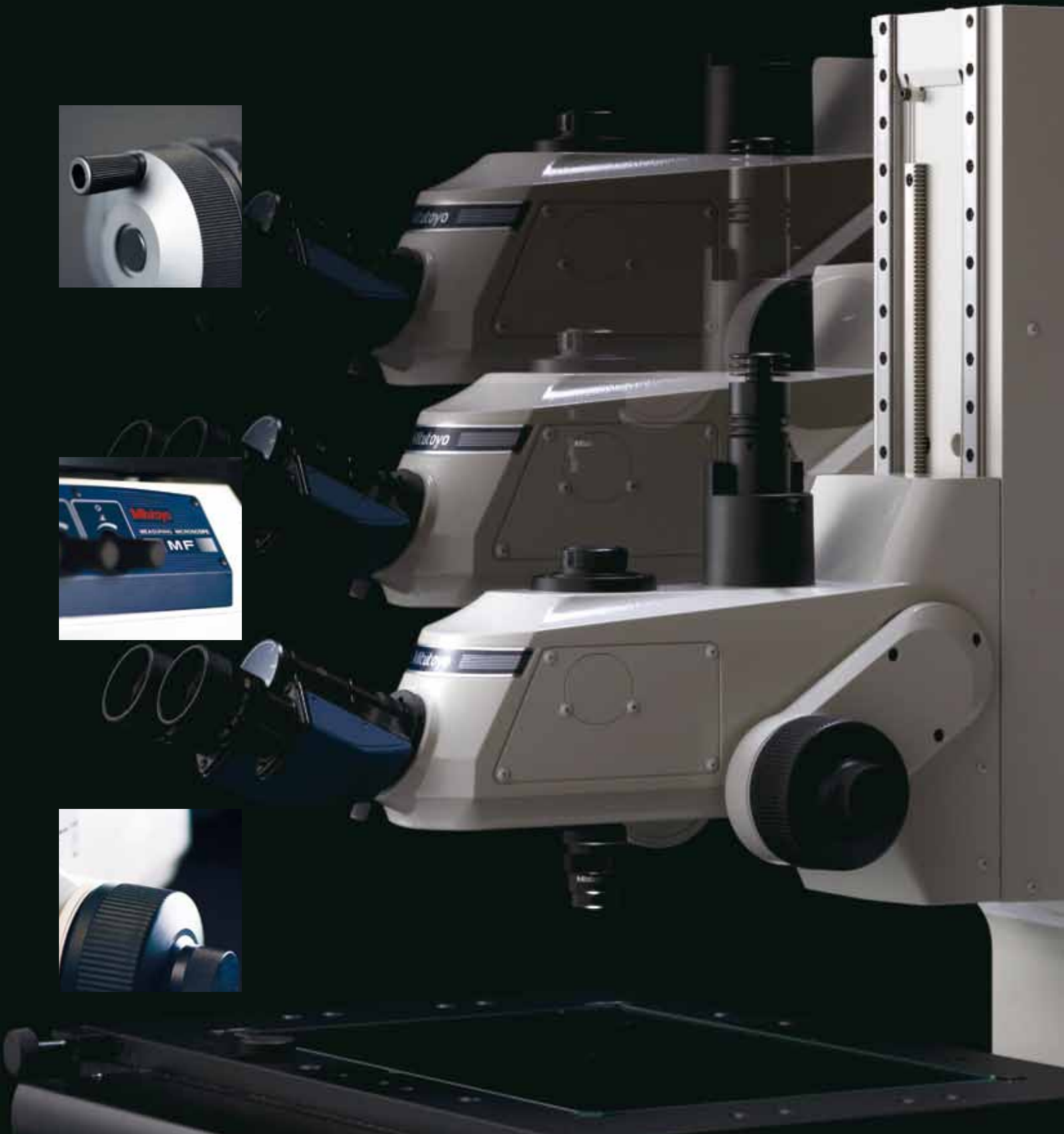

Superlative optical performance

Thanks to a new design of optical tube and modification of the objective lens specifications, flare that occurs within the optical system is suppressed as much as possible so that minute details on the workpiece are clearly shown. In addition, the internal black finish achieves a high image contrast and clear observation. The MF-U series is equipped with the established FS system metallographic microscope head which provides vivid images of high color reproducibility and features primary-color correction. (The objective lenses are plan apochromat*¹.) With much higher lighting efficiency in the optical system, which ensures sufficient illumination intensity, this series attains high-magnification measurements and a dark-field observation environment that is efficient and less tiring.

*¹ Image distortion and chromatic aberration in the wavelength range of the three primary colors (blue, yellow and red) are corrected.



Image brightness is about double compared with conventional microscopes.

Conventional microscope



Image of outer cover of floppy disk ^{*3}

MF/MF-U Series microscopes



^{*3}

Measuring accuracy approaching JIS level 0

Measuring microscopes must operate at a high level in terms of measuring accuracy and optical performance.

This series achieves the quoted measuring uncertainty for all stage sizes*². We believe that this series, which achieves a large measurement range and high accuracy at the same time, will help you in every measurement situation.

The digital scale built into the microscope body is a photoelectric type transmission linear encoder, with a maximum response speed of 50 m/min. This scale features high accuracy specifications developed in our underground research facility which is equipped with the world's highest scale accuracy evaluation technology. Mitutoyo acquired the first certification for calibration of line standards (standard scale of 500 mm or less) in Japan.

*² Measured conforming to the measurement method at each of the X and Y axes stipulated by JIS B 7153.

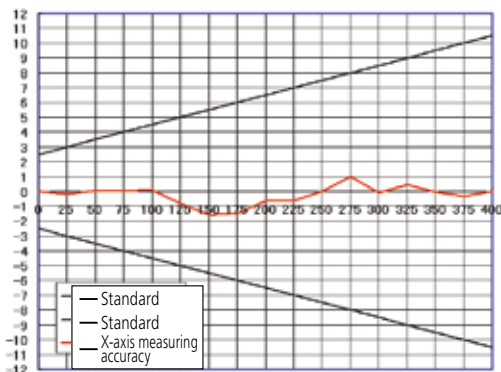

Uncertainty (X, Y) = $(2.5 + 0.02L) \mu\text{m}$

Reference: JIS B 7153 measuring microscope measuring accuracy at each axis (20°C)
 Level 0 ($2 + 0.01L$) μm or less Level 1 ($4 + 0.02L$) μm or less
 L = measurement length (mm)

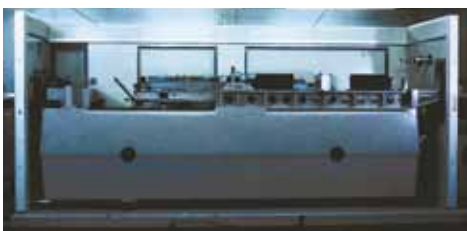

Line standard calibrator

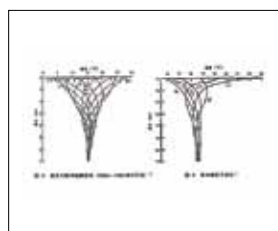

Underground facility temperature fluctuation graph

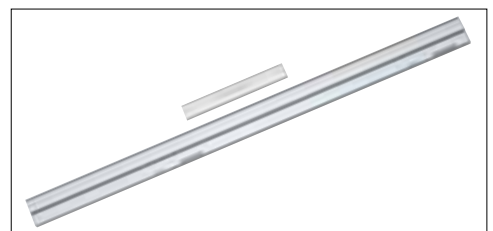

Glass scales

^{*3} Microscope images on this page are digital images, so they differ from the actual images.

Application Range



Observation and inspection of small areas

By using various types of illumination, the MF series can more precisely reproduce the colors and shapes of objects that are observed and inspected. The MF-U series microscopes are high value-added instruments that offer microscope observation functions such as dark-field mode (to observe surface scratches and small steps, which are difficult to see in bright-field mode), simple polarization (to observe coloration or contrast through the polarizer or analyzer using polarization properties), and differential interference (to observe small surface steps and other elements in color contrast using the polarization filter with a differential interference prism), as well as measurement functions.

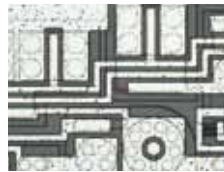

Bright-field observation



Dark-field observation



Polarized observation

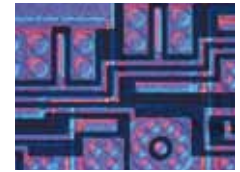

Differential interference observation



Anyone can easily photograph microscope images

Anyone can easily photograph microscope images by attaching a digital camera to the microscope. Because a general-purpose C-mount adapter is used, any digital camera model that supports C-mounting can be attached. For example, several people can simultaneously analyze and evaluate the microscope image displayed on the monitor, or generation of an inspection chart attached to the image can be automated.

In addition to taking photographs and printing data can be used to analyze images, send e-mail, and perform other tasks.



MF-B2010C + Vision Unit

Height measurement with a high focus repeatability

Focus reproducibility is important when measuring a vertical step or other element using the microscope. In particular, measurement errors due to the depth of focus of the objective lens are inevitable. The MF and MF-U series measuring microscopes have a focus pilot, which enhances focus repeatability. The focus pilot is mounted on the TV camera port section in the main unit as an add-on unit* and enables focusing position detection with high accuracy and repeatability. This realizes higher repeatability than a visual check and decreases variation in measured values caused by human error. Two types of focus patterns are available, either of which can be selected according to the size of the part to be focused on or the surface state, material, or other properties of the inspected object. A clear, bright, high-intensity LED (green or red) is employed as the light source. The focus pattern, for which brightness can be adjusted to any step, can be checked on the eyepiece or TV monitor. This substantially improves measurement throughput.

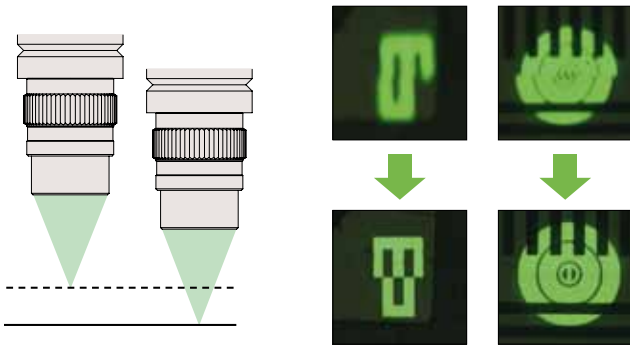

Ergonomic and High Performance Design Features

Wide-field observation

The best-in-class eyepiece field number*¹ of 24 mm (for WF10X) offers a wide viewing field that helps prevent extended observation or measurement from affecting your eyes or causing fatigue. The WF10X eyepiece, which was designed at the same time as the C series, has wider diopter adjustment ranges on the left and right sides than older products.



*¹ Width of an inspected object that can be seen across the whole viewing field when a 1X objective lens is used

LED and halogen light options for transmitted and reflected illumination (MF C and MF-U C)



Transmitted LED illumination part
(Common to MF C and MF-U C)

Reflected LED illumination part
(for MF C)

Reflected LED illumination part
(for MF-U C)

An LED or halogen light can be selected for the coaxial illumination in the main unit. While the conventional halogen light can be used for observation and measurement, the LED light can also be selected if you want to reduce the time lost to replace a failed halogen bulb with a new one and need high intensity illumination that quickly responds to brightness adjustment.

The LED light has a long working life*² and will not suddenly fail. In addition, the visibility, brightness and coloration are constant because, unlike fluorescent tubes, the LED light is free from glare and changes in color temperature. This means less eye fatigue after extended observation. Because the LED light consumes little power and emits little invisible radiation, measurement is economical, does not emit much heat, and therefore produces less heat-induced effects on inspected objects. In addition, this light source is impact resistant and does not contain environmental toxins. Therefore, you can confidently use it for a long time to come. All the models in the MF and MF-U series have transmitted and reflected illumination aperture-diaphragms as standard to enable observation and measurement with less light diffraction.

*² The working life will be shorter if the maximum illuminance is always used.



LED illumination



Halogen illumination

High visibility digital display

Because the resolution can be switched to 1 μm , 0.5 μm , or 0.1 μm for the digital display (two or three axes), which is a standard accessory for all models, high-discrimination measurement can be performed. The zero set, direction changeover, and smoothing functions are also standard. (Zero can be set using the switch near the X or Y handwheel.) Because the general-purpose RS-232C format is adopted for data transfer, data can be output to a standard printer or personal computer. It is also possible to output the display readings to spreadsheet software. The digital display can be installed on the left or right side of the column.



Front of display



Rear of display

Highly rigid column base

The base that supports the column holding the optical tube and the rest of the microscope must be absolutely rigid to enable observation and measurement using any amount of magnification. This series has been repeatedly evaluated from various aspects including a drop test*, transportation test*, and smoothing test and provides steady vision and consistent accuracy over the entire stroke. To enhance rigidity, horizontal ribs have been added within the column. The power supply section is located outside the base to reduce heat effects for higher base rigidity and highly accurate measurement.

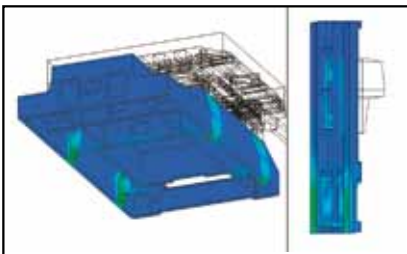

* Proprietary Mitutoyo tests executed using appropriate procedures. Column



Microscope-based high-resolution measurement

It is possible to build a manual image measurement system by equipping a measuring microscope with the image measurement option (the vision unit). Because the software constantly transmits stage displacements, measurements within the camera imaging range (on the screen) as well as those wider than the screen are supported. In addition, automatic edge detection provides an efficient measurement environment with a high throughput. However, eyepiece resolution might be superior to camera resolution in some cases. For example, the surface of a molded item made of black resin might be clearer to the naked eye than to the camera (monitor observation). Therefore, a measuring microscope that also enables you to see the surface and other elements is said to be a system that has a very high added value. It is recommended to connect the two-dimensional data processing unit QM-Data 200 (a dedicated control unit) to the measuring microscope for such dimensional measurement.



MF-B2010C + QM-Data 200

Ergonomic and High Performance Design Features

Quick release mechanism and zero set switch incorporated

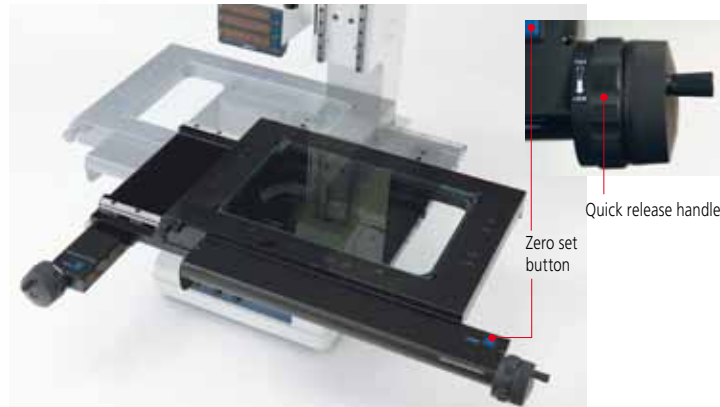

The stage movement can be switched between extremely coarse and fine (FREE and LOCK) by using the quick release handles on the X and Y handles. These handles are useful for freeing the stage when the distance to the measurement position is long or you want to quickly return to a reference position. Because this mechanism uses the twist roller method, switching causes little impact and enables smooth movement. Because the display zero set switches are located near the handles, you can focus on the eyepiece during measurement and keep your hand near the handle almost all the time except when adjusting the focus.

Stage variations including long stroke

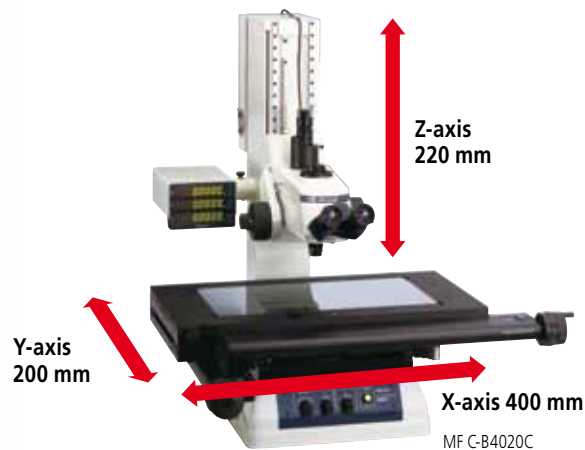

Inspected objects vary in size. Widely used in every industry, this series provides many measurement stroke variations. This series offers a stage for long stroke measurement of 400 × 200 × 220 (X × Y × Z) mm. This is useful when measuring printed circuit boards, shafts, knife tools and other objects. Although the standard model has a Z-axis range of 220 mm, the Z-axis can be extended with a column upgrade. A swivel rotation mechanism is also provided as standard. This mechanism is useful when fixing an inspected object in parallel with the table movement direction.

Z-axis handles provided on both sides of standard model



MF C



MF-U C

Because the Z-axis handles are placed on both sides of the column in standard models, the user can easily use one of them regardless of handedness. The digital display can also be installed on either side of the column to set up an environment suited to the user's dominant hand. Ergonomics have also been taken into consideration, and the handle is located in a position where a user of shorter stature can comfortably turn it.

Tilting optical tube of standard model (MF-U C)



Comfortable observation is possible because the eye point can be adjusted to a position suitable for the user's stature. The angle of the column can be fixed anywhere between 0° and 30°. The reticle in the optical tube can be replaced.

Sliding nosepiece (Factory installed option for MF C)



Usually, only one objective lens can be attached to an MF instrument (limited compensation optical system), and this must be replaced to change the magnification. Because up to two objective lenses can be attached to the sliding nosepiece, the magnification can be quickly changed when this option is specified.

Note: An external illumination source cannot be attached.

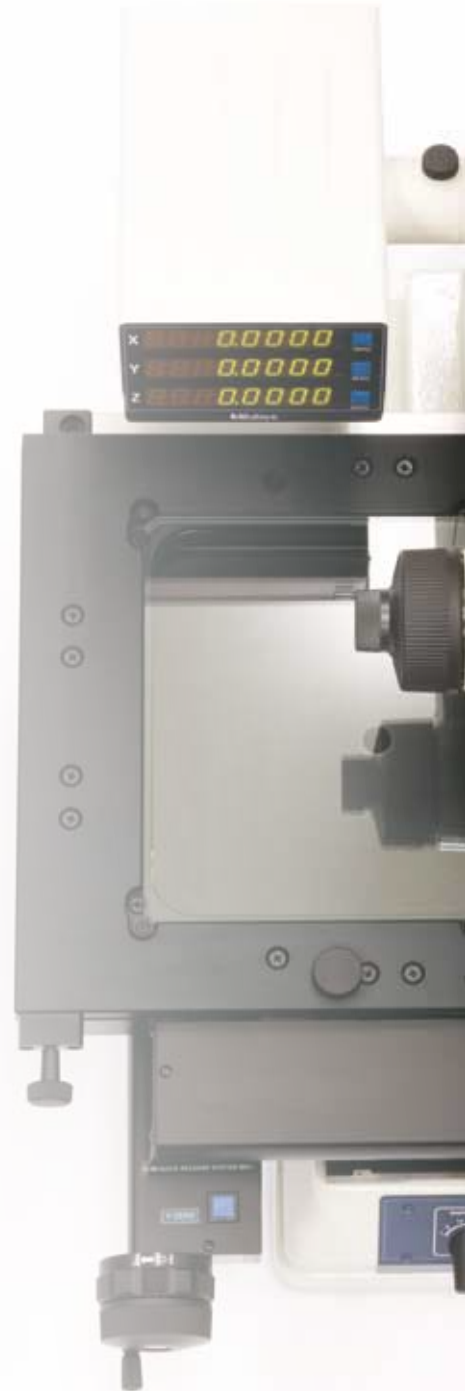

Measuring Microscope MF C-Series

Standard measuring microscopes with a broad variety of accessories



Features

- › Observation with a clear and flare less erect image and a wide field of view
- › Measuring accuracy that is the highest in its class (and conforms to JIS B 7153)
- › ML series, high-NA objectives that are specially designed for the MF series (long working distance type)
- › Illumination unit (reflected/transmitted) selectable from a high-intensity LED or halogen bulb (required)
- › Variable aperture diaphragm (reflected/transmitted) allows observation measurement while suppressing light diffraction
- › Variety of standardized stages in sizes up to 400×200 mm
- › Quick-release mechanism useful for moving the stage quickly when measuring workpieces that are large in size or quantity
- › Coarse/fine feed handles equipped as standard on both sides allow precise focus and observation measurement regardless of handedness
- › High-magnification eyepiece observation up to 2000X
- › Standard measuring microscope that has a wide variety of optional accessories including a Vision Unit and various digital CCD cameras
- › Low-noise design

Specifications

Without Z-axis scale	Model No.	MF-A1010C	MF-A2010C	MF-A2017C	MF-A3017C	MF-A4020C
	Order No.	176-662-10	176-663-10	176-664-10	176-665-10	176-666-10
With Z-axis scale	Model No.	MF-B1010C	MF-B2010C	MF-B2017C	MF-B3017C	MF-B4020C
	Order No.	176-682-10	176-683-10	176-684-10	176-685-10	176-686-10
Optical tube (eyepiece(s) required)		Monocular or binocular (angle of column: 25°) Standard TV camera port for all models, reticle (broken cross-hair, line width: 5 μm), optical path switching (observation/TV camera = 50/50)				
Observation image		Erect image				
Observation method		Bright-field observation				
Eyepiece (optional) Adjustable diopter		10X (eyepiece field number: 24), 15X, 20X Note: Monocular - one 10X eyepiece provided as standard; Binocular - two 10X eyepieces provided as standard				
Objective (optional)		ML objective 3X (provided as standard), 1X, 5X, 10X, 20X, 50X, 100X				
Z-axis	Max. workpiece height	150 mm			220 mm	
	Feed mechanism	Coaxial coarse and fine feed, handles on both sides (coarse: 30 mm /rotation, fine: 0.2 mm/ rotation)				
Illumination filter		One GIF filter is provided as standard (and mountable for both transmitted and reflected illumination)				
Stage	Measurement range (mm)	100×100	200×100	200×170	300×170	400×200
	Tabletop size (mm)	280×280	350×280	410×342	510×342	610×342
	Effective stage glass size (mm)	180×180	250×150	270×240	370×240	440×240
	Swiveling angle	—			±5° (left)	
	Maximum table loading (glass top)	10 kg			20 kg	
	Quick-release mechanism	Provided as standard for the X-and Y-axes				
Zero set button		Provided as standard for the X-and Y-axes (and for the Z-axis only for the MF-B type)				
Measurement system		High-accuracy digital scale*1				
Measuring accuracy*2 (X-and Y-axes, when not loaded)		(2.2+0.02L) μm, L: measuring length (mm)				
Digital display	Minimum reading	1/0.5/0.1 μm switchable				
	Display axes	X and Y (or X, Y, and Z only for the MF-B type)				
	Functions	Zero setting, direction switching, RS-232C output				
Main unit dimensions (W x D x H) mm		562×730×667	6248×745×667	632×892×782	682×892×782	757×907×782
Main unit mass		65.5 kg	69.5 kg	130 kg	138 kg	144 kg
Control unit dimensions and mass		114 (W)× 330 (D)× 90.5 (H) mm 2.0 kg				
Maximum power consumption (with the illumination unit)		LED: 45 W Halogen bulb: 160 W				

*1 Patent registered in Japan

Replacement halogen bulb (transmitted): Standard: **No. 513667** (12 V/ 50 W), Long life: **No. 12BAB345** (12 V/ 50 W)

*2 Measured in conformance with JIS B 7153

Replacement halogen bulb (reflected) (separate light source)

Illumination unit	LED	Halogen
Order No.	176-345*3	176-347*3
	Transmitted: Telecentric, built-in aperture diaphragm, white LED light source, non-stepped brightness adjustment, with cooling fan Reflected: Koehler illumination with adjustable aperture diaphragm, white LED light source, non-stepped brightness adjustment Control unit: Power switch (main switch), AC power supply input connector (100 to 240 V)	Transmitted: Telecentric, built-in aperture diaphragm, 12 V/ 50 W halogen lamp, non-stepped brightness adjustment, with cooling fan Reflected: Koehler illumination with adjustable aperture diaphragm, 12 V/ 50 W halogen lamp, non-stepped brightness adjustment, with cooling fan Control unit: Power switch (main switch), AC power supply input connector (100 to 240 V)

Note: Because the "Generation C type" does not have equipped the illumination unit, it is necessary to select the either LED illumination unit or Halogen illumination unit.

*3 To denote your AC line voltage add the following suffixes to the order No. (e.g.: **176-346A**): **A** for UL/CSA, **D** for CEE, **E** for BS, **DC** for China, **K** for EK, **C** for Taiwan, No suffix is required for JIS/100V

MF-B1010C

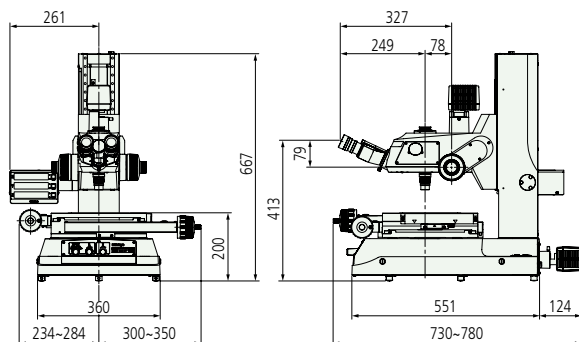

MF-B4020C

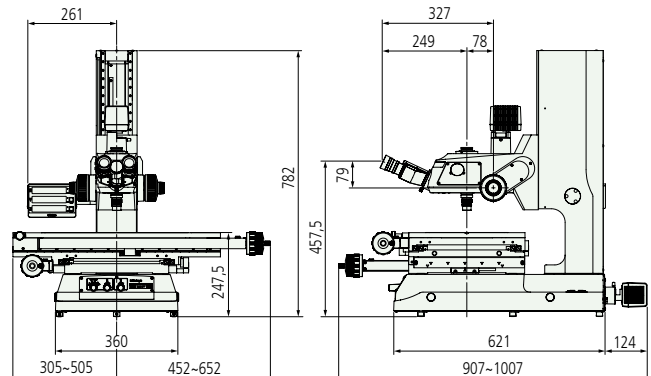

(Unit: mm)

Measuring Microscopes MF-U C Series

Standard measuring microscopes with a broad variety of accessories



Features

- › Observation with a clear and flare less erect image and a wide field of view
- › Measuring accuracy that is the highest in its class (and conforms to JIS B 7153)
- › Proven M Plan Apo/BD Plan Apo/G Plan Apo series, high-NA objectives from the FS optical system (long working distance type)
- › Integration of metallurgical and measurement microscope functions provides a high-resolution observation and high-accuracy measurement solution
- › Illumination unit (reflected/transmitted) selectable from a high-intensity LED or halogen bulb (required)
Only the halogen light source for transmitted illumination is provided as standard accessory. A separate light source for transmitted illumination must be ordered additionally as optional accessory.
- › Variable aperture diaphragm (reflected/transmitted) allows observation measurement while suppressing light diffraction
- › Variety of standardized stages in sizes up to 400 × 200 mm
- › Quick-release mechanism useful for moving the stage quickly when measuring workpieces that are large in size or quantity
- › Coarse/fine feed handles equipped as standard on both sides allow precise focus and observation measurement regardless of handedness
- › High-magnification eyepiece observation up to 4000X (when using M Plan Apo SL200X)
- › Standard measuring microscope that has a wide variety of optional accessories including a vision unit and various digital CCD cameras
- › Low-noise design

Specifications

With Z-axis scale	BF(brightfield)	Model No.	MF-UB1010C	MF-UB2010C	MF-UB2017C	MF-UB3017C	MF-UB4020C
		Order No.	176-688-10	176-689-10	176-690-10	176-691-10	176-692-10
	BD(brightfield/darkfield)	Model No.	MF-UD1010C	MF-UD2010C	MF-UD2017C	MF-UD3017C	MF-UD4020C
		Order No.	176-694-10	176-695-10	176-696-10	176-697-10	176-698-10
Optical tube		Tilting trinocular tube (angle of column: 0 to 30°), Siedentoph type (pupil distance adjustment: 51 to 76 mm), built-in 1X tube lens, reticle (broken cross-hair, line width: 5 μm), optical path switching (observation/TV camera = 50/50)					
Observation image		Erect image					
Observation method		BF, DF (only for MF-UC and UD types), simple polarization, differential interference					
Eyepiece (optional)		Adjustable diopter 10X (eyepiece field number: 24, two eyepieces provided as standard), 15X, 20X					
Turret (required)	Bright-field (BF)	Adjustable manual turret or adjustable power turret (Select one.)					
	Bright-field/dark-field (BD)	Adjustable manual turret or adjustable power turret (Select one.)					
Objective (optional)	Bright-field (BF)	All lenses including the M Plan Apo, M Plan Apo SL, and G Plan Apo series					
	Bright-field/dark-field (BD)	All lenses including the BD Plan Apo and BD plan Apo L series					
Focus system	Max. workpiece height	150 mm			220 mm		
	Feed mechanism	Coaxial coarse and fine feed, handles on both sides (coarse: 10 mm/ rotation, fine: 0.1 mm/ rotation)					
Stage	Measuring range (mm)	100×100	200×100	200×170	300×170	400×200	
	Tabletop size (mm)	280×280	350×280	410×342	510×342	610×342	
	Effective stage glass size (mm)	180×180	250×150	270×240	370×240	440×240	
	Swiveling angle	—			±5° (left)		±3° (left)
	Maximum table loading (glass top)	10 kg			20 kg		15 kg
	Quick-release mechanism	Provided as standard for the X- and Y-axes					
Zero set button		Provided as standard for the X-, Y- and Z-axes					
Measurement system		High accuracy digital scale *1					
Digital display	Minimum reading	1/ 0.5/ 0.1 μm switchable					
	Display axes	X-, Y- and Z-axes					
	Functions	Zero-setting, direction switching, RS-232C output					
Measuring accuracy*2 (X- and Y-axes, when not loaded)		(2.5+0.02 L) μm, L: measuring length (mm)					
Maximum power consumption		150 W					
Main unit	Dimensions (mm)	562 (W) × 730 (D) × 667 (H)	624 (W) × 745 (D) × 667 (H)	632 (W) × 892 (D) × 782 (H)	682 (W) × 892 (D) × 782 (H)	757 (W) × 907 (D) × 782 (H)	
	Mass	65.5 kg	69.5 kg	130 kg	138 kg	144 kg	
Control unit	Dimensions	114(W) × 330(D) × 90.5(H) mm					
	Mass	2.0 kg					

*1 Patent registered in Japan

*2 Measured in conformance with JIS B 7153

Replacement halogen bulb (transmitted)	Standard: No. 513667 (12 V/ 50 W)	Replacement halogen bulb (reflected) (separate light source)	For details, see p. 20
	Long life: No. 12BAB345 (12 V/ 50 W)		

illumination Unit	LED	Halogen
Order No.	176-346 *3	176-348 *3
	Transmitted: Telecentric, built-in aperture diaphragm, white LED light source, non-stepped brightness adjustment, with cooling fan Reflected: Koehler illumination with adjustable aperture diaphragm, white LED light source, non-stepped brightness adjustment Control unit: Power switch (main switch), AC power supply input connector (100 to 240 V)	Transmitted: Telecentric, built-in aperture diaphragm, 12 V/ 50 W halogen lamp, non-stepped brightness adjustment, with cooling fan Control unit: Power switch (main switch), AC power supply input connector (100 to 240 V)

Note: Because the "Generation C type" does not have equipped the illumination unit, it is necessary to select the either LED illumination unit or Halogen illumination unit.

*3 To denote your AC line voltage add the following suffixes to the order No. (e.g.: **176-346A**): **A** for UL/CSA, **D** for CEE, **E** for BS, **DC** for China, **K** for EK, **C** for Taiwan, No suffix is required for JIS/ 100 V

MF-UB2010C

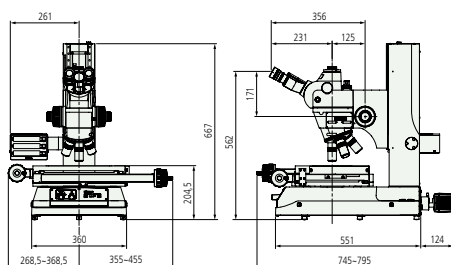

MF-UB3017C

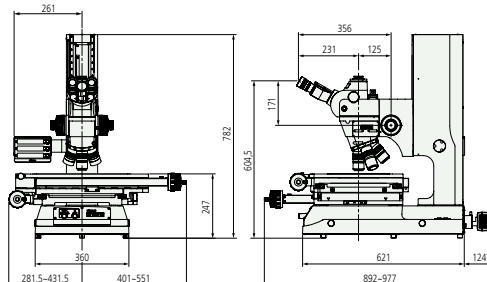

(Unit: mm)

Option Diagrams

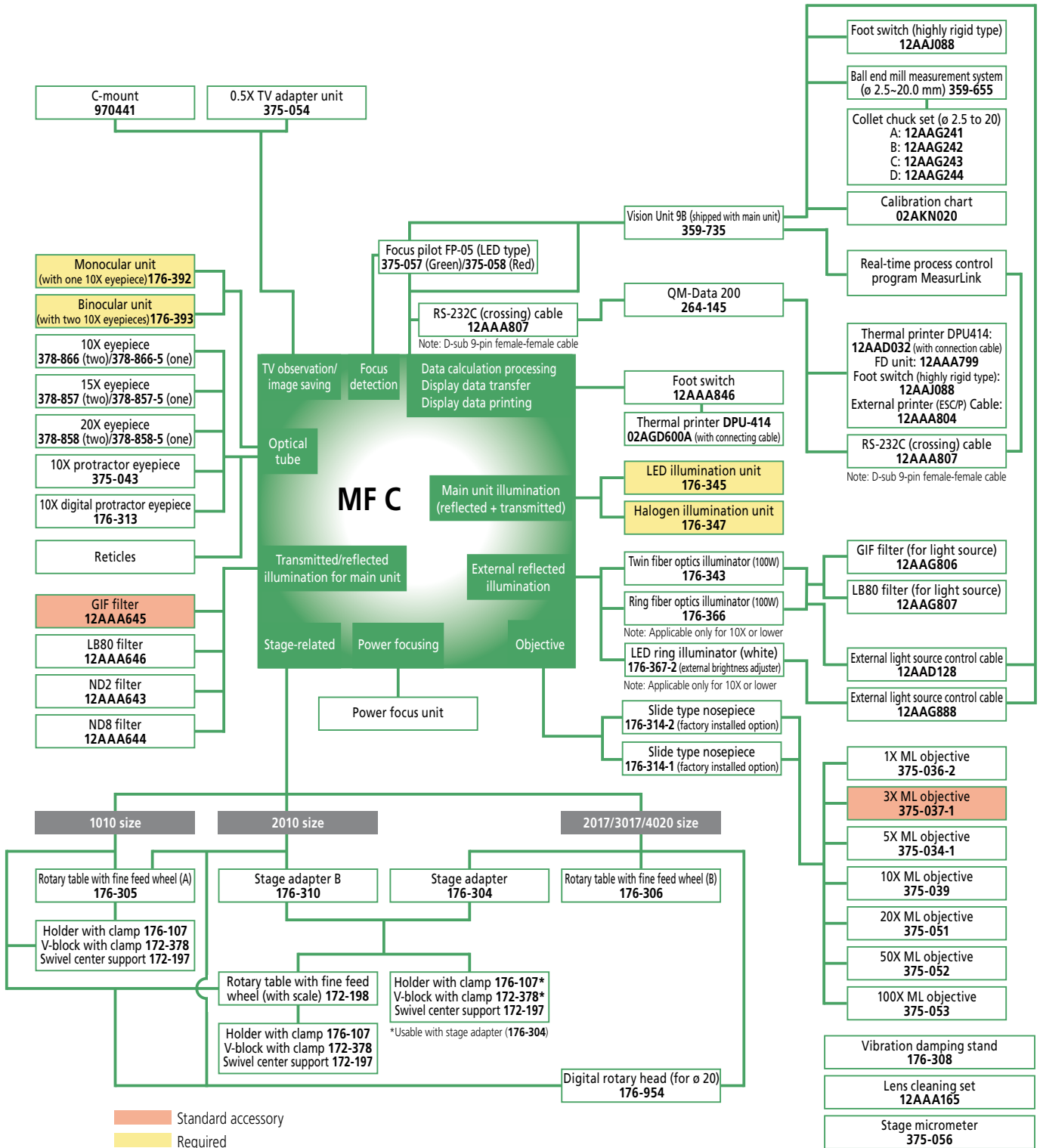

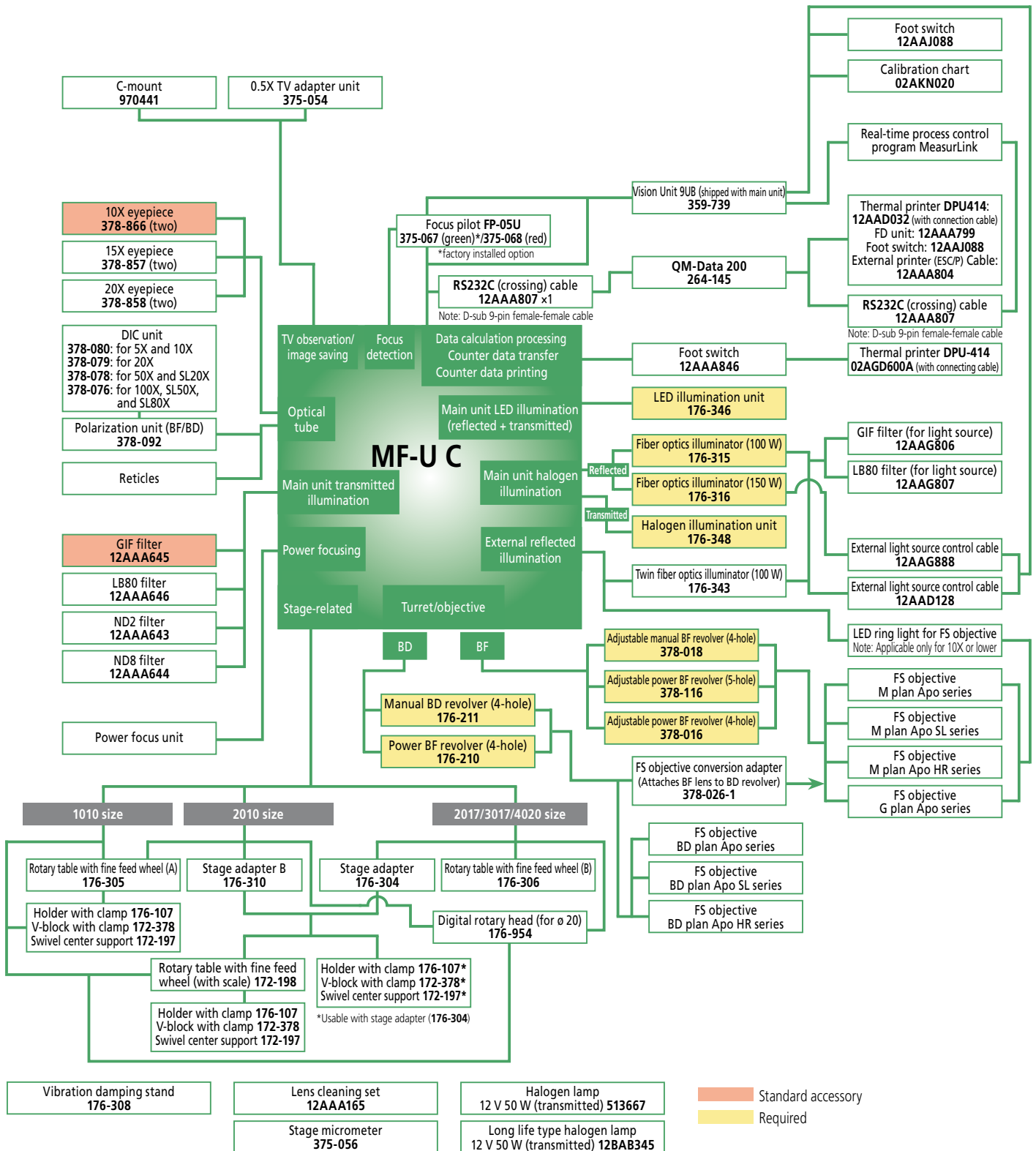

Lens Options

Naturally it is important that a user does not tire easily, even during lengthy periods of observation or measurement. Therefore these microscopes incorporate ergonomic design features such as widefield eyepieces (field number 24 for a 10X lens) and good eye relief to provide a relaxing view so that observation and measurement can be performed with minimal strain. Also, the standard objective lens series is a low-flare design with a long working distance. The FS objective lens for both BF and BF/DF are plan apochromat.

Optical tubes



Monocular Tube	
Order No.	176-392
Magnification	10X
Field number	24
Applicable model	MF C



Binocular Tube	
Order No.	176-393
Magnification	10X
Field number	24
Applicable model	MF C



Tilting Binocular Tubes	
Magnification	10X
Field number	24
Angle of column (tilted angle)	0 to 30°
Applicable model	Standard accessory for MF-U C

Eyepieces



Eyepiece	WF10X /24	WF15X /16	WF20X /1
Order No. (1)	378-856-5	378-857-5	378-858-5
Order No. (pair)	378-856	378-857	378-858
Magnification	10X	15X	20X
Field number	24	16	12
Applicable model	MF C / MF-U C		

Eye shade comes with 10X models.

MF C protractor eyepieces

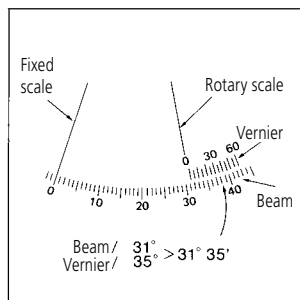

Protractor Eyepiece	
Order No.	375-043
Magnification	10X
Field number	21
Graduations	360° 5'
Applicable model	MF C



Digital Protractor Eyepiece	
Order No.	176-313*
Magnification	10 X
Field number	18
Eyepiece detection section	90° solid line, 45° broken line (line width: 5 μm for both)
Reticle	90° solid line, 45° broken line (line width: 5 μm for both)
Measuring range	Decimal degrees : 0.00° to ± 369.99°
Detection method	Degrees-minutes : 0°00' to ±369°59'
External dimensions (mm)	Electrostatic capacitance linear scale
Minimum reading	∅ 120 (OD) x 140 (D)
Digital counter (standard accessory) CE	0.01° (degree) or 1' (arc-minute)
Functions	Zeroset, ABS/INC switching, decimal degree / degree-minute switching, direction switching data output (with the foot switch No. 937179T)
External output	RS-232C
External dimensions (mm)	143 (W) x 112 (D) x 57 (H)
Power supply	100 to 120 VAC
Applicable model	MF C (can be fixed on the top of the counter.)

* To denote your AC line voltage add the following suffixes to the order No. (e.g.: 176-346A): **A** for UL/CSA, **D** for CEE, **E** for BS, **DC** for China, **K** for EK, **C** for Taiwan, No suffix is required for JIS/ 100 V

High resolution and long working distance of the objective lens are important factors promoting ease of operation when a microscope is used for inspection, observation or measurement. To obtain a clear image across the view field, apochromat specifications where chromatic aberration is compensated (compensation of red, blue, and yellow wavelengths) over a wide range of visible light are important, as are plan specifications where image surface warp, point aberration and other elements are compensated. FS objective lenses are high performance objective lenses combining these factors. This series has expanded the application range of microscopes and significantly improved ease of operation. M Plan Apo series are lenses for BF observation using visible light. BD Plan Apo series can be used for BF and DF observation. SL (Super Long) specifications are useful when a longer working distance is required. G Plan Apo series are lenses that enable observation through glass. Glass thickness is compensated for 3.5 mm (2 to 5 mm custom designs are available).

ML objective lenses

Limited correction optical system for MF



Model No.	Order No.	Magnification	N.A.	Working distance (mm)	Depth of focus ± (μm)
ML 1X	375-036-1	1X	0.03	61	306
ML 3X	375-037-1	3X	0.09	77	34
ML 5X	375-034-1	5X	0.13	61	23
ML 10X	375-039	10X	0.21	51	6.2
ML 20X	375-051	20X	0.42	20	1.6
ML 50X	375-052	50X	0.55	13	0.9
ML 100X	375-053	100X	0.70	6	0.6

FS objective lenses

Unlimited correction optical system for MF-U C

For bright-field (BF) observation and measurement



Model No.	Order No.	Magnification	N.A.	Working distance (mm)	Depth of focus ± (μm)
M Plan Apo 1X	378-800-3	1X	0.025	11.0	440
M Plan Apo 2X	378-801-6	2X	0.055	34.0	91
M Plan Apo 5X	378-802-3	5X	0.140	34.0	14
M Plan Apo 10X	378-803-3	10X	0.280	33.5	3.5
M Plan Apo 20X	378-804-3	20X	0.420	20.0	1.6
M Plan Apo 50X	378-805-3	50X	0.550	13.0	0.9
M Plan Apo 100X	378-806-3	100X	0.700	6.0	0.6
M Plan Apo SL 20X	378-810-3	20X	0.280	30.5	3.5
M Plan Apo SL 50X	378-811-3	50X	0.420	20.5	1.6
M Plan Apo SL 80X	378-812-3	80X	0.550	15.0	1.1
M Plan Apo SL 100X	378-813-3	100X	0.700	13.0	0.9
M Plan Apo SL 200X	378-816-3	200X	0.620	13.0	0.7
M Plan Apo HR 50X	378-814-4	50X	0.750	5.2	0.48
M Plan Apo HR 100X	378-815-4	100X	0.900	1.3	0.34
G Plan Apo 20X (t 3.5)	378-847	20X	0.280	30.6 (with glass) 29.42 (without glass)	3.5
G Plan Apo 50X (t 3.5)	378-848-3	50X	0.500	15.08 (with glass) 13.89 (without glass)	1.1
Lens set B1	378-911	Set of M Plan Apo 10X, 20X, 50X, and 100X			
Lens set B2	378-912	Set of M Plan Apo 2X, 5X, 10X, and SL20X			
Lens set B3	378-913	Set of M Plan Apo 5X, 10X, 20X, and 50X			
FS objective lens conversion adapter	378-026-1	Used when setting the bright-field BF lens onto the BF/DF BD revolving nosepiece.			

For BF/DF (BD) observation and measurement



Model No.	Order No.	Magnification	N.A.	Working distance (mm)	Depth of focus ± (μm)
BD Plan Apo 2X	378-831-7	2X	0.055	34.0	91
BD Plan Apo 5X	378-832-7	5X	0.140	34.0	14
BD Plan Apo 10X	378-833-7	10X	0.280	34.0	3.5
BD Plan Apo 20X	378-834-7	20X	0.420	20.0	1.6
BD Plan Apo 50X	378-835-7	50X	0.550	13.0	0.9
BD Plan Apo 100X	378-836-7	100X	0.700	6.0	0.6
BD Plan Apo SL 20X	378-840-7	20X	0.280	30.5	3.5
BD Plan Apo SL 50X	378-841-7	50X	0.420	20.0	1.6
BD Plan Apo SL 80X	378-842-7	80X	0.500	13.0	1.1
BD Plan Apo SL 100X	378-843-7	100X	0.550	13.0	0.9
BD Plan Apo HR 50X	378-845	50X	0.750	5.2	0.48
BD Plan Apo HR 100X	378-846	100X	0.900	1.3	0.34
Lens set D1	378-931	Set of BD Plan Apo 10X, 20X, 50X, and 100X			
Lens set D2	378-932	Set of BD Plan Apo 2X, 5X, 10X, and SL20X			
Lens set D3	378-933	Set of BD Plan Apo 5X, 10X, 20X, and 50X			

Note: For more lenses see our brochure "Microscope Units" (PRE1299)".

Illumination Options

How illumination (a light source) is used is important for observing and measuring various inspected objects such as semiconductors, electronic or electric components, automobile precision components, resin moldings, tools, medical products, and printed materials with clarity and high contrast. Select the best illumination according to the shape, surface conditions, color, and materials in the inspected object.

A: Reflected illumination and transmitted illumination (required)



LED illumination unit	
Order No.	176-345*
	Made up of lamp housing (for reflected illumination and transmitted illumination) and an LED control unit. The LED control unit can be fixed to the rear of the column of the microscope main unit. White light LED (low power consumption: 65 W) Rated life of approximately 30,000 hours continuously variable brightness control. Built-in cooling fan (includes an alarm for indicating that the fan has stopped). A color filter can be attached to a reflected or transmitted illumination unit.
External dimensions (mm)	Reflected illumination unit: $\varnothing 33 \times 86$ (maximum protrusion) Transmitted illumination unit: 68×103 (maximum protrusion) LED control unit: 118 (W) \times 365 (D) \times 96 (H)
Applicable model	MF C



LED illumination unit	
Order No.	176-346*
	Made up of lamp housing (for reflected illumination and transmitted illumination) and an LED control unit. The LED control unit can be fixed to the rear of the column of microscope main unit. White light LED (low power consumption: 70 W). Rated life: Approximately 30,000 hours. Continuously variable brightness control. Built-in cooling fan (includes an alarm for indicating that the fan has stopped). A color filter can be attached to a reflected or transmitted illumination unit.
External dimensions (mm)	Reflected illumination unit: 68×66 (maximum protrusion) Transmitted illumination unit: 68×103 (maximum protrusion) LED control unit: 118 (W) \times 365 (D) \times 96 (H)
Applicable model	MF-U C



Halogen illumination unit	
Order No.	176-347* (MF C)/176-348* (MF-U C)
	Made up of lamp housing (for reflected illumination and transmitted illumination) and a halogen control unit. The halogen control unit can be fixed to the rear of the column of the microscope main unit. 12 V, 50 W halogen lamp, continuously variable brightness control. Built-in cooling fan (includes an alarm for indicating that the fan has stopped) A color filter can be attached.
External dimensions (mm)	Reflected and transmitted illumination unit: 91×106 (maximum protrusion) Halogen control unit: 118 (W) \times 365 (D) \times 96 (H)
Applicable model	MF C/MF-U C

Note: MF-U C is available only for transmitted illumination.



100W and 150W fiber optics cable illumination unit (external light source)	
Order No.	176-315* (100W)
	12 V, 100 W halogen lamp (No. 517181) Rated life: 1,000 hours 12 V, 100 W high brightness halogen lamp (No. 12BAD602) Rated life: 50 hours Continuously variable brightness control
External dimensions (mm)	76 (W) \times 235 (D) \times 120 (H), Fiberglass cable length: 1,500
Order No.	176-316D (150 W)
	15 V, 150 W halogen lamp (No. 12BAJ076) Rated life: 500 hours 15 V, 150 W high brightness halogen lamp (No. 12BAJ075) Rated life: 50 hours Continuously variable brightness control
External dimensions (mm)	120 (W) \times 273 (D) \times 119 (H), Fiberglass cable length: 1,500
Applicable model	For reflected illumination when selecting the halogen illumination unit (No. 176-348) with MF-U C

* To denote your AC line voltage add the following suffixes to the order No. (e.g.: **176-345A**): **A** for UL/CSA, **D** for CEE, **E** for BS, **DC** for China, **K** for EK, **C** for Taiwan, No suffix is required for JIS/ 100 V

A: Reflected and transmitted illumination

The light is projected vertically downward onto the surface of an inspected object through an objective. An LED or halogen lamp is selectable as the light source.



B: Dual swan-neck light pipe

Light piped from a standalone halogen lamp unit and projected from two heads is suitable for three-dimensional observation. The condenser lens included as standard makes high brightness spot lighting possible.

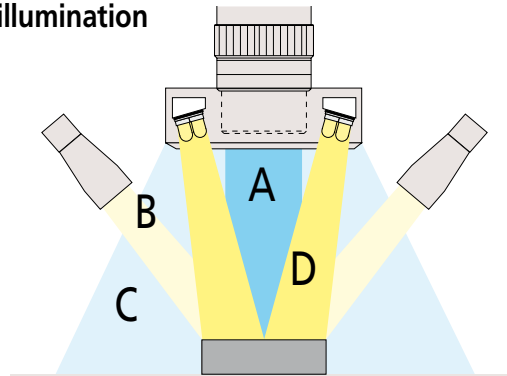

The four images show the same portion of an inspected object.

C: Fiber-optic ring light

Light piped from a standalone halogen lamp unit and projected from around the objective enables observation that is less affected by shadows due to surface irregularities and is suitable for image measurement.



D: LED ring light

Light from an LED array surrounding the objective enables high contrast observation of deeply colored resins, circuit boards, and small cylindrical objects and is also suitable for image measurement. In addition, adjusting the brightness does not change the coloring.



B: Dual swan-neck light pipe

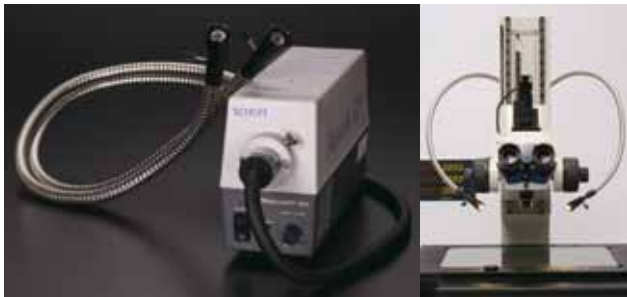

Dual swan-neck light pipe (external light source)	
Order No.	176-343*
	Fixed to the rear of the microscope column. Continuously variable brightness control. Includes a condenser lens. Auto-brightness control can be used for the vision unit system (with external light source control cable No. 12AAD128). 12 V, 100 W halogen lamp (No. 517181), rated life: 1,000 hours 12 V, 100 W high brightness halogen lamp (No. 12BAD602), rated life: 50 hours. LB80 filter (No. 12AAG807)
External dimensions (mm)	76 (W) x235 (D) x120 (H): includes only the light source Fiber optics cable length: 700 (from the rear fixed portion to the front edge) Maximum fiber bending radius: 60
Applicable model	MF C / MF-U C

C: Fiber-optic ring light



Fiber-optic ring light (external light source)	
Order No.	176-366*
	Continuously variable brightness control. Includes a condenser lens. Auto-brightness control can be used for the vision unit system (with external light source control cable No. 12AAD128). 12 V, 100 W halogen lamp (No. 517181) Rated life: 1,000 hours. 12 V, 100 W high brightness halogen lamp (No. 12BAD602) Rated life: 50 hours. LB80 filter (No. 12AAG807)
External dimensions (mm)	76 (W) x235 (D) x120 (H): includes only the light source Circular illumination unit: outside diameter: 60, inside diameter: 35 Maximum fiber length: 1,000
Applicable model	MF C (ML objective 10X or lower model)

* To denote your AC line voltage add the following suffixes to the order No. (e.g.: **176-345A**): **A** for UL/CSA, **D** for CEE, **E** for BS, **DC** for China, **K** for EK, **C** for Taiwan, No suffix is required for JIS/ 100 V

Illumination Options

A: Reflected and transmitted illumination

The light is projected vertically downward onto the surface of an inspected object through an objective. An LED or halogen lamp is selectable as the light source.



B: Dual swan-neck light pipe

Light piped from a standalone halogen lamp unit and projected from two heads is suitable for three-dimensional observation. The condenser lens included as standard makes high brightness spot lighting possible.

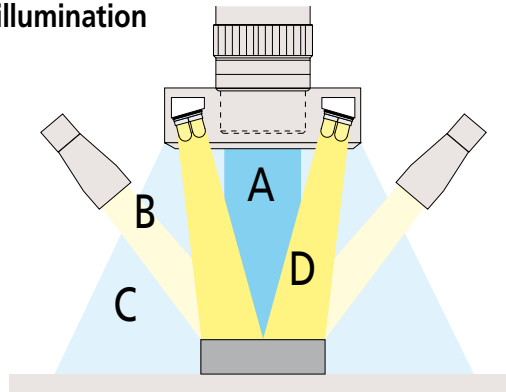

The four images show the same portion of an inspected object.

C: Fiber-optic ring light

Light piped from a standalone halogen lamp unit and projected from around the objective enables observation that is less affected by shadows due to surface irregularities and is suitable for image measurement.



D: LED ring light

Light from an LED array surrounding the objective enables high contrast observation of deeply colored resins, circuit boards, and small cylindrical objects and is also suitable for image measurement. In addition, adjusting the brightness does not change the coloring.



D: LED ring light



LED Ring Light	
Order No.	176-367-2*
	Continuously variable brightness control. Auto-brightness control can be used for the vision unit system (with external light source control cable No. 12AAG888).
External dimensions (mm)	75 (W) x150 (D) x90 (H): only the control part Ring LED part: outside diameter: 70, height: 68 to 93 LED cable length: 1,500
Applicable model	MF C (ML objective 10X or lower model)

D: LED ring light



LED ring light (for FS objectives)	
Order No.	Please contact us.*
	Fixed to an objective and projects ring-shaped white LED light. Continuously variable brightness control. Auto-brightness control can be used for the vision unit system (with external light source control cable No. 12AAG888).
External dimensions (mm)	75 (W) x150 (D) x90 (H): only the control part Ring LED part: outside diameter: 70, height: 65 to 80 LED cable length: 1,000
Applicable model	MF-U C (FS objective M plan Pro 10X or lower model)

* To denote your AC line voltage add the following suffixes to the order No. (e.g.: **176-345A**): **A** for UL/CSA, **D** for CEE, **E** for BS, **DC** for China, **K** for EK, **C** for Taiwan, No suffix is required for JIS/ 100 V

2-D Data Processing Unit QM-Data 200



MF-UD2010C with QM-Data200

Features

- > Auto edge detection tool and various macro icons to perform measurement at once
- > Easy-to-use graphics and measurement navigation
- > Enables measurement results to be output to MS-Excel®* and an inspection table created on the same PC
- > Enables tolerance zone analysis for measurement and calculation results, and various types of statistical processing for each item
- > Auto-brightness control that precisely duplicates an illumination setting (when using the measuring microscopes MF C and MF-U C together)
- > Enables high-accuracy height measurement when combined with the focus pilot
- > Enables measurement within one screen
- > Images can be input or saved (in BMP or JPEG format).

* MS-Excel is a Microsoft product.

Specifications

QM-DATA 200 (stand type)

Order No.	264-155
Displayed language	Switched among 16 languages (Japanese, English, French, German, Italian, Spanish, Portuguese, Czech, Chinese (traditional), Chinese (simplified), Korean, Turkish, Swedish, Polish, Dutch, Hungarian).
Unit of measurement	Length: mm, angle: degree/degree-minute-second (switchable)
Resolution	0.1 μm
Program function	Creating, performing, and editing measuring procedures
Statistical processing	The measured item, number of data items, maximum value, minimum value, average value, standard deviation, range, histogram, and statistics for each measuring function (statistics for each command)
Display field	Colour graphics LCD (with a backlight)
Tilt feature	Available
I/O connector	XYZ: for linear scale input ... up to 3 axes RS-232C Ⓞ: for connecting a PC (measuring result) RS-232C Ⓢ: for connecting the counter of the measuring machine main unit OPTOEYE: for inputting edge signal from OPTOEYE FS: for connecting a foot switch PRINTER: for connecting a receipt or external printer (measuring result) USB-FDD: for connecting a USB-FDD (measuring result file, measuring procedure file) USB-MEMORY: for connecting USB memory (measuring result file, measuring procedure file)
File output of measuring result	RS-232C output (CSV format, MUX-10 format)
Power supply	100 V to 240 V AC
Maximum power consumption	17W (without including options)
External dimensions (mm)	Approximately 260 x242 x310 mm (including a stand)
Weight	Approximately 2.9 kg
Applicable model	MF C/MF-U C

External dimensions (Unit: mm)

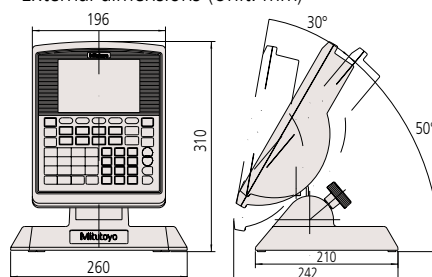

Thermal printer DPU-414



Specifications

Thermal printer DPU-414

Order No.	Connected to QM-Data 200	12AAD032
Order No.	Counter display printing	02AGD600A Note: Combined use with footswitch No. 12AAA846
Printing method	Dot-matrix thermosensitive	
Number of printing digits	40 digits (9 normal characters (7 dot matrix))	
Printing speed	Maximum 52.5 normal characters/s	
External dimensions	160 mm (W) x170 mm (D) x65.5 mm (H) (printer)	
Standard accessories	Printer cable, printing paper (1 roll), AC adapter (for 100 V)	
Spare goods	Printing paper	No. 908353-1 (1 roll)
	ESC/P printer cable	No. 12AAA804 (2 m) 24 pin for color and monochrome

Printout example

ND0001	X =	2.8005	Y =	10.4220
ND0002	X =	1.0490	Y =	7.4525
	D =	0.0217	F2 =	0.0056
ND0003	X =	2.1000	Y =	1.8285
	Y =	-1.0145		
ND0004	X =	1.6150	Y =	1.6150
	Y =	0.0000	AC =	9.2758

Image Measurement Option Vision Unit

Measurement results can be instantly displayed by specifying the desired command from various options based on the digital counter output on the microscope main unit. Highly versatile electronic and image measurement functions, where image processing is used to align edges, are available. The measurement results can be printed and output to a spreadsheet application or inspection table.



MF-B4020C mit Vision Unit

Features

- › Automatic edge detection tool that enables instant measurement and a variety of macro types
- › Graphics and measurement navigation function that supports easy operation
- › Measurement results can be output to MS-Excel^{®*}, and an inspection table can be created using the same personal computer.
- › Tolerance zone measurement and per-item statistical processing
- › Auto-brightness control function that exactly reproduces illumination settings (when the MF and MF-U measuring microscopes are used at the same time)
- › High accuracy height measurement is possible with the aid of the focus pilot
- › Measurement within a single screen image
- › Functions to input and save images

* MS-Excel is a registered trademark of Microsoft Corporation.

Instant manual measurement

The CCD camera integrated into the microscope automatically detects the edge of the target and instantly displays operation results if the edge is within the video screen. In addition to fewer edge alignment errors, higher repeatability and reduction of measurement time, simultaneous monitoring of measured points is also possible.

Specifications

Vision Unit	
Order No.	359-797 (for MF-C); 359-799 (for MF-U C)
Optical magnification	0.5X when installed into the microscope (with the 0.5X TV adapter)
Image detection	High-sensitivity 12.70 mm (1/2") CMOS colour camera 3 Mega Pixels
Monitor display magnification	Approximately 19X (when using a 3X lens: approximately 57X, imaging range: 4.5 x 3.3 mm)
Maximum resolution	0.1 μ m
Measuring accuracy at each axis (measurement temperature: 20 °C)	Depends on the accuracy of measuring microscope. Reference: Repeatability on a single screen (Mitutoyo reference samples were used.) With 3X objective lens: $3\sigma = \pm 2.5 \mu$ m or less With 10X objective lens: $3\sigma = \pm 1.0 \mu$ m or less
Software	QS PAK vision unit edition
Maximum power consumption	420 W (incl. monitor)
Applicable model	MF C/MF-U C

QSPAK VUE®

In order to support various measuring methods from measurement of a wide variety of single parts to CNC measurement of mass production parts, QSPAK® has achieved both high-reliability vision detecting capability and user-friendly operability.

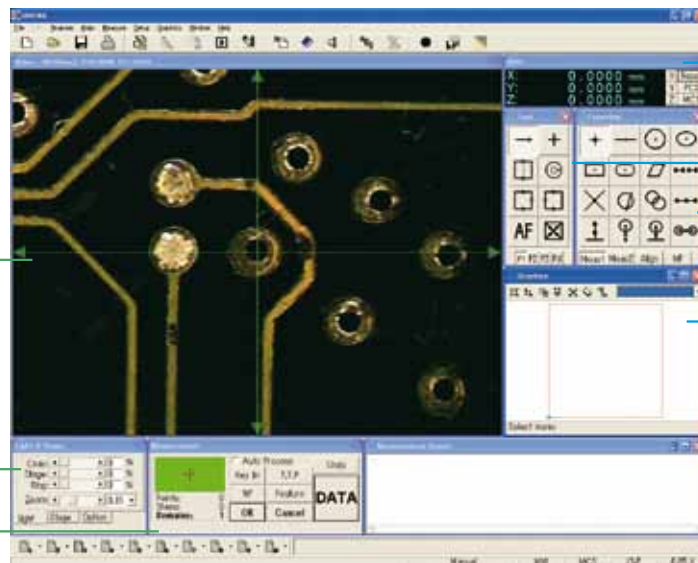

Video window

Counter window

Tools window

Functions window

Graphics window

Illumination/stage window

Measurement window

Example of internal diameter measurement

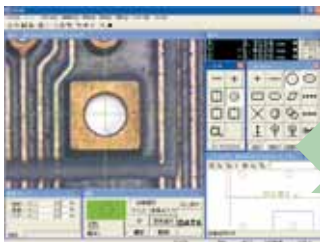

(1) Display the target to be measured in the video window and adjust illumination and focus on the main unit of the measuring microscope.

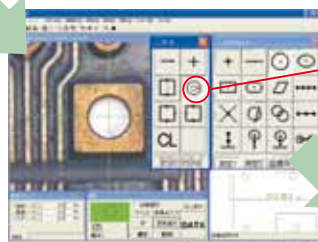

One-Click circle tool

(2) Select the measurement function "Circle Measurement" from the function window and the edge detection tool "One-Click Circle Tool" from the tool window.

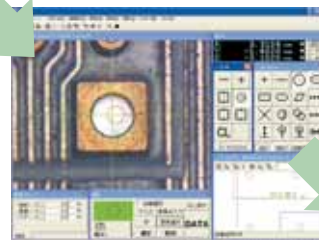

(3) Click on the edge of the target hole once: the edge is automatically detected and the measurement process started.



(4) Measurement results are displayed.

Optional Accessories





We offer options that support the ease of operation of measuring microscopes. A focus pilot that reduces the dispersion of the focusing point, power revolving nosepiece and power focus unit that enable changing magnification and focusing by hand, a digital rotary head which digitally measures angles, a rotary table with a fine feed wheel enabling smooth rotational movement of the target, and other options are highly developed. Choose options such as polarization and differential interference contrast units which support metallographic microscope observation, TV port adapter for setting the camera required for multiple users to simultaneously perform analysis and evaluation according to the application.



Focus pilot

Mounted onto the TV port of the microscope main unit as an add-on function, the focus pilot can detect the focus point with high accuracy and reproducibility. Adjustment of the brightness of the focus pattern is possible according to the surface condition, material, and other characteristics of the target. The internal 0.5X optical system enables a wide field of view on the TV monitor. (A separate CCD camera needs to be mounted.)

Note: Combination of MF-U and FP-05U is a factory-fit option.

Focus detection unit focus pilot		
Model type	FP-05	FP-05U
Order No.	375-057* (green) / 375-058* (red)	375-067* (green) / 375-068* (red)
Light source	Green LED or Red LED	
	<ul style="list-style-type: none"> Concentric circle pattern  	<ul style="list-style-type: none"> Slit pattern  
	<ul style="list-style-type: none"> The focal point is the position where the top and bottom of the pattern are aligned. The brightness can be adjusted according to the reflectivity of the surface. Observation with a wide field of view on a TV monitor using 5X optical magnification is available. 	
Focusing reproducibility	Approximately 1.5 μm (when using a 20X lens) ... This is a reference value based on an inspection performed using our standard sample.	
Optical magnification	0.5X	
Magnification accuracy	$\pm 0.1\%$ (within 2/3 of the center of the field of view)	
Camera	Supports up to 16.93 mm (2/3 inch)	
TV adapter	Equipped with C-mount, centering or parfocal adjusting mechanism	
Power supply	100 to 240 V AC, Maximum power approximately 10 W	
External dimensions (mm)	Main unit: 131(H)	
	Console box: 90 (W) x 78 (H) x 178 (D)	
Applicable model	MF C	MF-U C

Note: The combination of MF-U and FP-05U is a factory-installed option.

* To denote your AC line voltage add the following suffixes to the order No. (e.g.: **176-345A**): **A** for UL/CSA, **D** for CEE, **E** for BS, **DC** for China, **K** for EK, **C** for Taiwan, No suffix is required for JIS/ 100 V

Digital rotary head



Order No.	176-954*1
	This unit digitally displays the rotation angle. Indexing angles is possible.
Digital angle display	0.1° or 0.05° (switchable) The accuracy is not guaranteed.
Rotation	Manual (The head is rotated 50% per handle rotation.)
Clamping range for the collet chuck (mm)	ø2.5 to 20 Note: The collet chuck is an option.
Power supply	100 to 240 V AC Maximum power consumption: approximately 8.4 W
External dimensions (mm)	160 (W) ×220 (D) ×88 (H)
Applicable model	MF C

*1 To denote your AC line voltage add the following suffixes to the order No. (e.g.: **176-345A**): **A** for UL/CSA, **D** for CEE, **E** for BS, **DC** for China, **K** for EK, **C** for Taiwan, No suffix is required for JIS/ 100 V

Collet chuck set



Set A (No. 12AAG241)	Clamping range: ø 2.5 to 5 mm
Set B (No. 12AAG242)	Clamping range: ø 5.5 to 10 mm
Set C (No. 12AAG243)	Clamping range: ø 10.5 to 15 mm
Set D (No. 12AAG244)	Clamping range: ø 15.5 to 20 mm
Applicable model	MF C

Slide type nose pieces (Factory-installed option)



Order No.	176-314-1 The lens mounted at the centering mechanism (standard) position and the lens mounted at the focal point adjusting mechanism position are parfocal. Note: The magnification of the lens mounted at the focal point adjusting mechanism position is not guaranteed.
Order No.	176-314-2 Magnification of the lens mounted at the centering mechanism (standard) position and that of the lens mounted at the focal point adjusting mechanism position are guaranteed. Note: The two lenses are not parfocal.
Applicable model	MF C

Note: An external light source is not available with this product.

Turrets



Order No.	378-018	176-211	378-016*2	378-116*2	176-210*2
Supported observation	For bright-field (BF)	For bright-field and dark-field (BD)	For bright-field (BF)	For bright-field (BF)	For bright-field and dark field (BD)
Number of ways	4	4	4	5	4
Centering and parfocal mechanism	Standard fixed: 1 position Centering and parfocal: 3 positions	—	Standard fixed: 1 position Centering and parfocal: 3 positions	Standard fixed: 1 position Centering and parfocal: 4 positions	—
Driving method	Manual		Electric		
Power supply	—	—	100 to 240 V AC		
External dimensions (mm)	ø 110 ×51 (H)	—	Turret: 164 (W) ×65 (H) ×137 (D) Console box: 108 (W) ×72 (H) ×193 (D)		Cable length: 3 m
Applicable model	Required for MF-U C				

*2 To denote your AC line voltage add the following suffixes to the order No. (e.g.: **176-345A**): **A** for UL/CSA, **D** for CEE, **E** for BS, **DC** for China, **K** for EK, **C** for Taiwan, No suffix is required for JIS/ 100 V

Electric focus unit



Order No.	152865 (complies with the RoHS directive)
	Attached to the Z-axis handle on the left side of the microscope to allow fine focus adjustment by turning the electric jog dial by hand. By using a jog shuttle, the variable speed coarse feed focus can be changed in 7-levels.
Maximum feed	0.4 μm
Maximum drive speed	3.2 mm/s
Driving method	Stepping motor (jog shuttle/jog dial)
Power supply	100 to 240 V AC Maximum power consumption: approximately 20 W
External dimensions (mm)	Main unit: ø 69 ×99 (L) Console box: 108 (W) ×72 (H) ×193 (D)
Applicable model	MF C/MF-U C

This unit is made to order. (Inquiry No. **152865**)

Optional Accessories

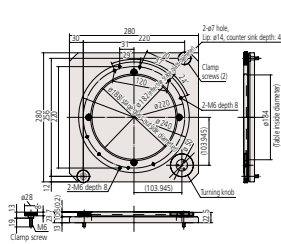

Rotary table with fine feed wheel (A)	
Order No.	176-305
External dimensions (mm)	280 (W) x 280 (D) x 24 (H) mm Table top: ø 240 mm, 360° rotation, no angle reading
Weight	5.5 kg
Effective glass size (mm)	ø 183
Applicable model	505 / 1010 / 2010 size (MF C / MF-U C)

Note: The V-block with clamp, swivel center, and adjustable clamp can be fixed onto the table.

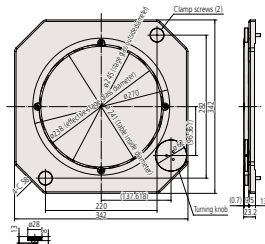

Rotary table with fine feed wheel (B)	
Order No.	176-306
External dimensions (mm)	342 (W) x 342 (D) x 23 (H) mm Table top: ø410mm, 360° rotation, no angle reading
Weight	6.5 kg
Effective glass size (mm)	ø 240
Applicable model	2017 / 3017 / 4020 size (MF C / MF-U C)

Note: The V-block with clamp, swivel center, and adjustable clamp cannot be fixed onto the table.

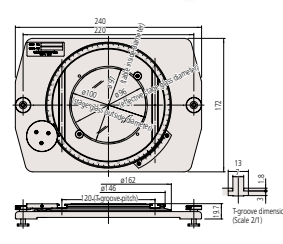
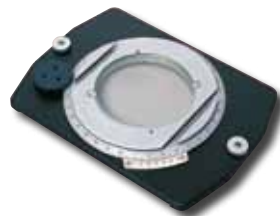

Rotary table with fine feed wheel (graduated)	
Order No.	172-198
External dimensions (mm)	240 (W) x 172 (D) x 19.7 (H) mm, table top T-slot pitch: 120 Table top: ø 146 mm, 360° rotation, minimum angle reading vernier: 2'
Weight	2.5 kg
Effective glass size (mm)	ø 94
Applicable model	MF-C / MF-U C Note: Use stage adapter B in for the 2010 size model. Use stage adapter A for the 2017, 3017, and 4020 size models.

Note: The V-block with clamp, swivel center, and adjustable clamp can be fixed onto the table.



V-Block with clamp	
Order No.	172-378
	Maximum supportable diameter: ø 25 mm High from the mounted surface to the center: 38 to 48 mm
External dimensions (mm)	117 (H) x 90 (W) x 45 (D) mm
Weight	0.8 kg
Applicable model	MF C / MF-U C Note: Use stage adapter B for the 2010 size model. Use stage adapter A for the 2017, 3017 and 4020 size models.



Swivel center	
Order No.	172-197
	Can be tilted within $\pm 10^\circ$, minimum angle reading: 1" Most appropriate for measurement screws and other items
	Maximum supportable size: 80 x 140 mm when horizontal Maximum supportable size: 65 x 140 mm when tilted by 10°
Weight	2.5 kg
Applicable model	MF C / MF-U C Note: Use stage adapter B for the 2010 size model. Use stage adapter A for the 2017, 3017, and 4020 size.



Adjustable clamp	
Order No.	176-107
Maximum clamp length (mm)	35
External dimensions (mm)	62 (H) x 152 (W) x 38 (D) mm
Weight	0.4 kg
Applicable model	MF C / MF-U C Note: Use stage adapter B for the 2010 size model. Use stage adapter A for the 2017, 3017, and 4020 size.

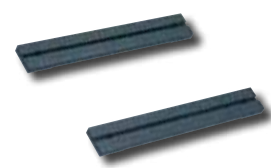

Stage adapter A/B	
Order No.	A : 176-304 / B : 176-310
External dimensions, one piece (mm)	50 (W) x 340 (D) x 15 (H) mm Note: The depth of adapter B is 280 mm.
Weight	A : 1.5 kg / B : 1.2 kg
Applicable model	MF C / MF-U C

Note: One pair in a set



Polarization unit	
Order No.	378-092 (common to BF and BF/DF) Polarizer and analyzer one each per set.
Applicable model	MF-U C



Differential interference units	
Order No.	378-080 (for 5 X and 10 X) 378-079 (for 20 X) 378-078 (for 50 X and SL20 X) 378-076 (for 100 X, SL80 X, and SL50 X)
Applicable model	MF-U C



C-mount	
Order No.	970441
	Standard adapter used to mount a digital camera or other device onto the TV camera port of the microscope main unit. Note: Not used when an Vision Unit is mounted.
External dimensions (mm)	ø 45 x 22.5 (H)
Applicable model	MF C / MF-U C



0.5 X TV adapter (with C-mount)	
Order No.	375-054
	Standard adapter used to mount a digital camera or other device onto the TV camera port of the microscope main unit. 0.5 X reduction relay image enables wide field observation. Magnification accuracy: ± 0.1%, image view field: ø 11 mm Note: Supplied as standard with the vision unit.
External dimensions (mm)	ø 45 x 123 (H)
Applicable model	MF C / MF-U C



Illumination filters		
For the light source in the microscope main unit*	GIF filter	12AAA645
	LB80 filter	12AAA646
	ND2 filter	12AAA643
	ND8 filter	12AAA644
For the light source of reflected illumination (for 100 W fiber-optic illumination)	GIF filter	12AAG806
	LB80 filter	12AAG807



Lens Cleaning Kit	
Order No.	12AAA165
	Dedicated to eyepiece and objective lens maintenance Set of cleaner, cloth, blower, cotton wads, and other items
Applicable model	MF C (common to transmitted and reflected illumination)/ MF-U C (transmitted illumination only)

* MF (for both transmitted and reflected illumination) / MF-U (for transmitted illumination only)

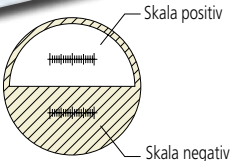

Stage micrometer	
Order No.	375-056
Scale graduation	1 mm
Minimum graduation	0.01 mm
Scale accuracy (20°C)	1 + L (µm), L: length between any two lines (mm)
Graduations	Negative/positive type
External dimensions (mm)	76 (W) x 26 (D) mm
Weight	16 g
Applicable model	MF C / MF-U C

Note: Mitutoyo supports calibration after purchase. For details, contact your nearest sales office.

Vibration damping stand	
Order No.	176-308
Supporting	Spring pad
Maximum loading	200 kg
External dimensions (mm)	750 (W) x 550 (D) x 36 (H) mm
Weight	36 kg
Applicable model	MF C / MF-U C

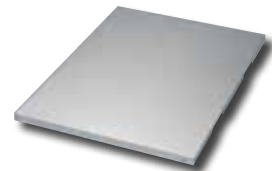

Optional Accessories Reticles

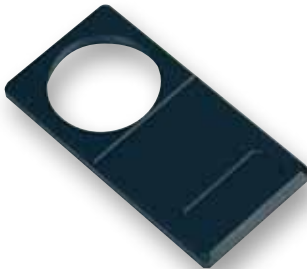

For MF C

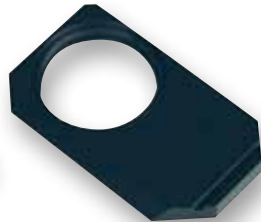

For MF-U C

	No.12AAG836 (MF C) No.12AAG877 (MF-U C) 90° broken line Broken line pitch: 0,2/0,2 Line width: 5 µm
	No.12AAG873 (MF C) No.12AAG876 (MF-U C) 90° broken line Broken line pitch: 0,2/0,2 Line width: 3 µm

	No. 12AAG839 (MF C) No. 12AAG879 (MF-U C) 90° solid line, 45° broken line Broken line pitch: 0,2/0,2 Line width: 5 µm
--	---

	No. 12AAG840 (MF C) No. 12AAG880 (MF-U C) 90° solid line, 60° broken line Broken line pitch: 0,2/0,2 Line width: 5 µm
--	---

	No. 12AAG841 (MF C) No. 12AAG881 (MF-U C) Zeiss-Schablone Broken line pitch: 0,2/0,2 Line width: 5 µm
--	--

	No. 12AAG842 (MF C)*1 Cross hairs graduated line 0,1 / 20 mm Line width: 7 µm
--	---

	No. 12AAG843 (MF C)*1 Concentric circles with cross hairs ø 1,2 to ø 18 Line width: 7 µm
--	---

	No. 12AAG844 (MF C)*1 Graduated line 0,1 / 10 mm Line width: 10 µm
--	--

	No. 12AAG845 (MF C)*1 Graduated line 0,05 / 5 mm Line width: 10 µm
--	--

	No. 12AAG846 (MF C)*1 Grid 1 mm x 1 mm, 10 mm x 10 mm Line width: 10 µm
--	--

	No. 12AAG847 (MF C)*2 Metric coarse screw thread P = 0,25 to 1,0 Line width: 7 µm
--	--

	No. 12AAG848 (MF C)*2 Metric coarse screw thread P = 1,25 to 2,0 Line width: 7 µm
--	--

	No. 12AAG849 (MF C)*2 Involute gear reference rack m = 0,1 to 1,0 pressure angle: 14,5° Line width: 7 µm
--	---

	No. 12AAG850 (MF C)*2 Involute gear reference rack m = 0,1 to 1,0 pressure angle: 20 ° Line width: 7 µm
--	--

	No. 12AAG851 (MF C)*2 Unified coarse screw thread 80 to 28 Line width: 7 µm
--	--

	No.12AAG852 (MF C)*2 Unified coarse screw thread 24 to 14 Line width: 7 µm
--	---

	No.12AAG853 (MF C)*2 Unified coarse screw thread 13 to 10 Line width: 7 µm
--	---

	No.12AAG854 (MF C)*2 Concentric circles with cross hairs 0,01" to 0,20" Line width: 7 µm
--	---

	Reticle for digital protractor eyepiece (standard) 90° solid line 45° broken line Broken line pitch: 0,2 / 0,2 Line width: 5 µm
--	---

Each reticle is supplied with a mounting bracket.

*1 To be used with the eyepiece 10 X.

*2 Comparison chart for ML 3 X objective lens. To be used with 10 X eyepiece.

Optional Accessories



Mitutoyo opti-fix

The opti-fix system allows the quick and safe solution of very different tasks using only a few components. In case of measuring methods using reflected as well as transmitted light for measurement of cubic, rotationally symmetrical and especially flat workpieces, the use of opti-fix is a really practical solution.

Furthermore, the spring clips and centering pins of different design which are integrated in the system allow also tactile measuring. Mitutoyo opti-fix offers the user a large number of possibilities for part fixing, form clamping tweezers for miniature test specimens to precision vice for large parts.

Mitutoyo opti-fix round

The innovative, newly developed tool "Mitutoyo opti-fix round" completes the opti-fix types in the true sense of the word "the wheel comes full circle".

The circular design allows an infinitely variable adjustment of 360° in horizontal level as well as in space and additionally, the "pin fixing" at the sides ensures a user-friendly access to the workpiece.

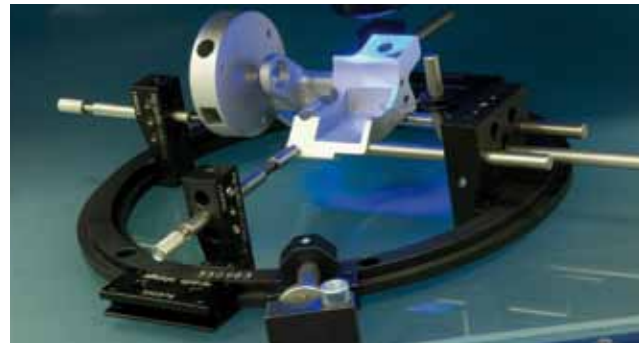



Ask for the brochure "Microscope Units and Objective Lenses".

Get detailed information about our lenses featuring large working distances for various viewing requirements.



Ask for the brochure "Mitutoyo opti-fix".

Get concise information about Mitutoyo's innovative and economically priced clamping system.

- Coordinate Measuring Machines
- Vision Measuring Systems
- Form Measurement
- Optical Measuring
- Sensor Systems
- Test Equipment and Seismometers
- Digital Scale and DRO Systems
- Small Tool Instruments and Data Management

Mitutoyo Europe GmbH
Borsigstraße 8-10
41469 Neuss
Germany
T +49 (0) 2137 - 102-0
F +49 (0) 2137 - 102-351
info@mitutoyo.eu
www.mitutoyo.eu

Note: Product illustrations are without obligation. Product descriptions respectively capability characteristics are only binding when explicitly agreed upon.

