

PH10T motorised probe head

Gain access to your work-piece with a PH10T

The PH10T is a motorised probe head designed to increase throughput by giving DCC machines the added capability of probe re-orientation. This enables the probe to inspect features at different angles without the need for frequent, time-consuming, stylus cluster changes.

It is compatible with a range of M8 touch trigger probes and extension bars, allowing the size and position of critical features to be determined.

The PH10T is an established product that provides a cost-effective method of probe orientation.



Key benefits

Increased throughput

The ability of the PH10T to index automatically allows easy part programming, without the need for expensive stylus clusters.

Improved accuracy

The PH10T can achieve 0.5 μm repeatability at 62 mm radius, providing accurate positioning even when using long extensions.

Increased reach and flexibility

Extension bars up to 300 mm long together with the full range of Renishaw M8 probes can be used with PH10T.

Innovations

Repeatable kinematic location

The PH10T uses six point kinematic location for each of its 720 positions making its locking mechanism extremely repeatable.

UCC compatibility

The PH10T can be used in conjunction with Renishaw's UCC controller family providing a comprehensive solution.

Specification

Weight	645 g (22.7 oz)
CMM mounting	Shank (a variety of shanks are available from Renishaw)
Probe mounting	M8 thread
Suitable controller	PHC10-2 (RS232 and IEEE versions available) or, PHC10/50 UCC daughter card
Repeatability of position	0.5 µm (0.00002 in) specified at a distance of 62 mm (2.44 in)
Cycle time	
75° move:	2.5 seconds
90° move:	3.5 seconds
Total angular movement	
A axis	0° to 105° in 7.5 steps
B axis	0° to ±180° in 7.5 steps
Total number of positions	720
Maximum drive output torque	0.45 Nm
Maximum extension bar	300 mm (11.8 in) using PEL4 extension
Temperature range	
Operating:	10 °C to 40 °C (50 °F to 104 °F)
Storage:	-10 °C to 70 °C (14 °F to 158 °F)
Hand control unit	HCU1

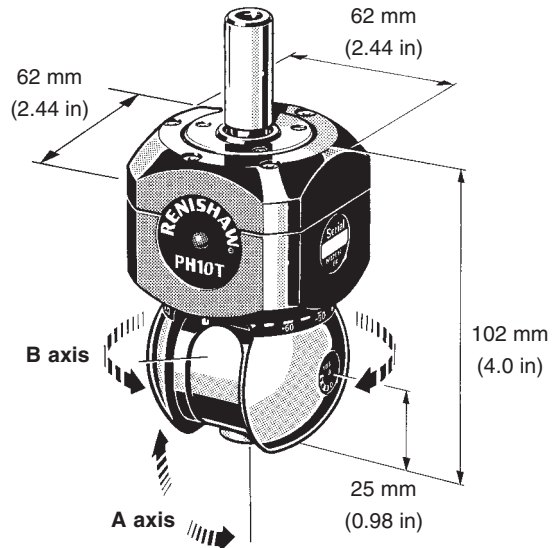

Additional information

Other variants of the PH10T are also available. These are PH10MQ and PH10M. For further details on these enhanced products refer to www.renishaw.com/PH10.

A variety of shanks are also available for PH10T, depending on your CMM. In order to select the correct PH10 kit for your machine refer to www.renishaw.com/PH10T.

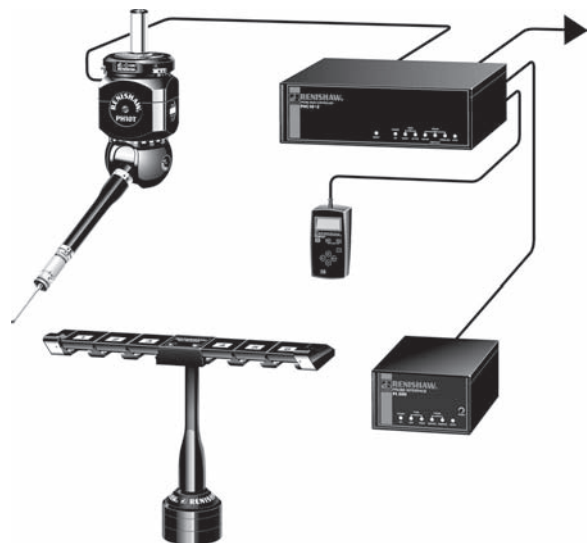

For worldwide contact details, please visit our main website at www.renishaw.com/contact