

Willrich Precision  
Ph 866-945-5742  
sales@willrich.com

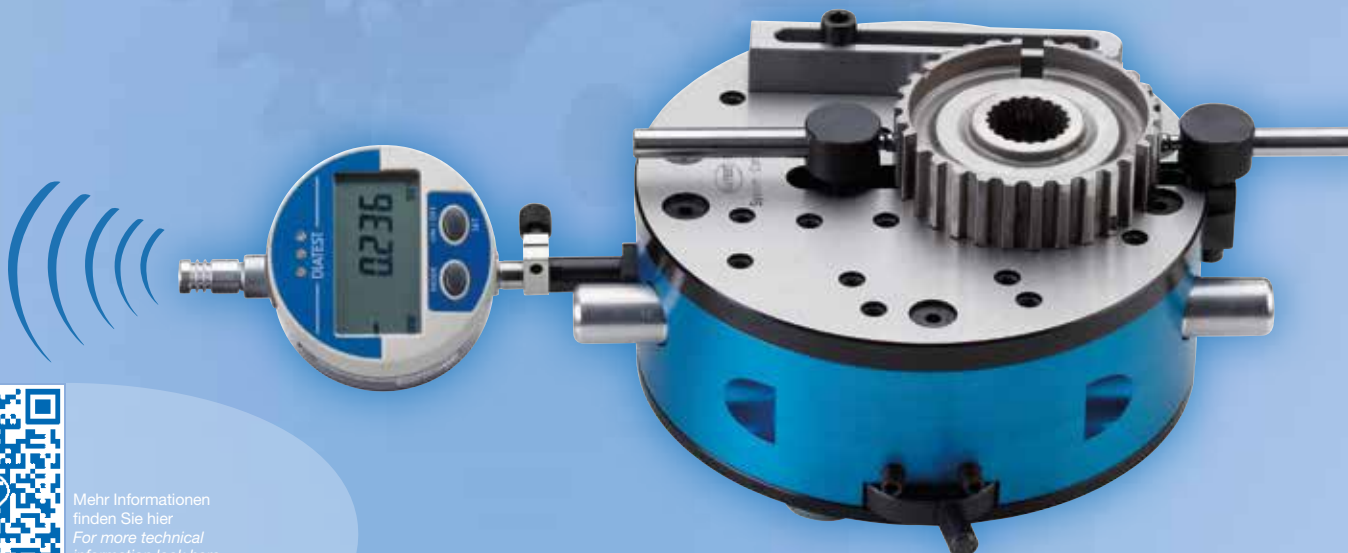

**System DIA-COME**  
**System DIA-COME**



Mehr Informationen  
finden Sie hier  
*For more technical  
information look here*  
DIATEST Anzeigende Messgeräte  
DIATEST Indicating bore gauges

Seite	Page
<b>3</b> DIATEST System Come	<b>3</b> DIATEST System Come
<b>4</b> DIA-COME C2 Messtische für Ø (Bohrungsmessungen)	<b>4</b> DIA-COME C2 Measuring Tables for Ø (Bore Gauging)
<b>5</b> DIA-COME C2 Kits für Ø (Bohrungsmessungen)	<b>5</b> DIA-COME C2 Kits for Ø (Bore Gauging)
<b>6</b> DIA-COME C2 Messtische für Verzahnung	<b>6</b> DIA-COME C2 Measuring Tables for Gear Gauges
<b>7</b> DIA-COME C2 Kits für Verzahnung	<b>7</b> DIA-COME C2 Kits for Gear Gauges
<b>8</b> DIA-COME Ausrichtung und Einstellmeister	<b>8</b> DIA-COME Adjustment and Setting Master
<b>9</b> DIA-COME Messtisch-Bestandteile	<b>9</b> DIA-COME Components of a Measuring Table
<b>10</b> DIA-COME Anwendungsbeispiele	<b>10</b> DIA-COME Sample Applications
<b>12</b> DIA-COME C3 Messtische	<b>12</b> DIA-COME C3 Measuring Tables
<b>13</b> DIA-COME C3 Kits	<b>13</b> DIA-COME C3 Kits
<b>14</b> DIA-COME Zubehör	<b>14</b> DIA-COME Accessories

# DIA-COME Messtische:

## DIA-COME measuring tables:

**Mit den flexiblen Messtischen nach DIATEST System COME (DIA-COME) können Sie Innen- und Außendurchmesser sowie Verzahnungen messen.**

Durch die äußerst robuste Ausführung sowie die einfache Bedienung und schnelle Montage eignen sich die Messtische ideal für den Einsatz in der Produktion oder der Werkstatt. Die Tische widerstehen vielen Ölen, Emulsionen oder Spänen und zeigen sich gleichzeitig überaus einfach in der Bedienung. Das Messen kann durch den Werker selbst erfolgen, so kann der Prozess der Kontrolle in die laufende Produktion mit eingebunden werden, man spart Zeit und Kosten.

DIA-COME Messtische gibt es in verschiedenen Größen, Ausführungen und Messbereichen und können Dank des vielfältigen Zubehörs viele Messaufgaben wahrnehmen, wie bspw. in Innen- oder Außennuten, Konzentritäten oder Konizitäten. Ergänzt wird das Ganze noch durch Anwendungspakete (Kits), mit denen die häufigsten Messaufgaben bequem gelöst werden können.

Die Wiederholgenauigkeit liegt bei  $\pm 2 \mu\text{m}$ . Die Messkraft lässt sich stufenlos regulieren, so dass Werkstücke nicht deformiert oder beschädigt werden. Angeschlossen werden können analoge oder digitale Messuhren mit einer Klemmung 8h7 (3/8" Zoll), induktive oder inkrementelle Messtaster, PC, DIATRON oder Drucker. Messdaten können natürlich bei Verwendung einer geeigneten Anzeige per Echtfunk übertragen werden. Für die korrekte Messwertanzeige ist eine Messuhr für die Außenmessung notwendig.

**You can measure internal and external diameters as well as gear gauges with the flexible measuring tables DIATEST System COME (DIA-COME).**

Due to its sturdy construction, simple handling and quick installation the measuring tables are suitable for use in both inspection & production areas. The measuring tables are coolant and swarf resistant, at the same time they are very easy to handle. The measurement can be made by the machine operator himself during the production process. This saves time and money.

DIA-COME measuring tables are offered in different sizes, layouts and measuring ranges. Many different measuring tasks (for example inside- and outside grooves, concentricity or tapers) can be checked thanks to the wide range of accessories. Additional application kits (Kits) provide solutions for the most common measuring tasks.

Measuring repeatability is  $\pm 2 \mu\text{m}$ . In order not to distort or damage the work piece the measuring force can be continuously adjusted. Mechanical or digital indicators with a 8h7 or 3/8" clamping, inductive or incremental probes, PC, DIATRON or printer can be connected. Measured data can be transferred wirelessly when using a suitable indicator. An indicator for the measurement of outer diameters has to be used for the accurate display of measured data.

# Stabil – Flexibel – Ökonomisch

## Sturdy – Flexible – Economic



## DIA-COME C2 Messtische für Ø (Bohrungsmessungen)

### DIA-COME C2 Measuring Tables for Ø (Bore Gauging)

#### DIA-COME C2 Messtische zum Messen von Innen- und Außendurchmessern (Bohrungsmessungen) und Verzahnungen.

Die DIA-COME C2 Messtische sind in drei Größen verfügbar und decken unterschiedliche Messbereiche ab. C2 Messtische haben einen beweglichen und einen festen Messkontakt. Durch die variable Montage des festen Messkontakts erfolgt die Anpassung auf das gewünschte Maß. Der bewegliche Messkontakt hat einen Messbereich von 20 mm. Der Messweg wird direkt 1:1 auf eine Messwertanzeige übertragen.

Alle Messtische sind als Basistische "Base" ohne Messkontakte und als vollwertige Messtische mit Messkontakten erwerbbar. C2 Messtische sind auch mit Zoll-Klemmung erhältlich.

#### DIA-COME C2 measuring tables for the measurement of I.D. and O.D. and gear gauging.

DIA-COME C2 measuring tables are available in 3 sizes covering different measuring ranges. C2 measuring tables have a fixed and a moving measuring contact. The required measurement can be achieved by fitting the fixed measuring contact. The moveable measuring contact has a measuring range of 20 mm. The measuring travel is transferred 1:1 to the measuring indicator.

All measuring tables are available as basic tables ("Base") without measuring contacts, or as fully complete measuring tables including measuring contacts. C2 measuring tables are also available with 3/8" clamping.

#### DIA-COME C2

Abb./Picture 5.01

Messbereich Measuring Range	Innen Ø I.D. Ø 30 – 105 mm	Außen Ø O.D. Ø 0 – 90 mm
Inhalt Basistisch C2 Base Content of basic table C2 Base	Messtisch mit 1 Klemmstück CO-CP und 1 Messeinsatz-Halter CO-MH38 Measuring table with 1 Clamping Pin CO-CP and 1 Measuring Contact Support CO-MH38	
Inhalt Messtisch C2 Content of gauge C2	Wie C2 Base, zusätzlich mit 1 Messeinsatz CO-MI16-25 und 2 Messeinsätzen CO-MI16-52 As C2 Base, additionally with 1 Measuring Contact CO-MI16-25 and 2 Measuring Contacts CO-MI16-52	

#### DIA-COME C2 AL

Abb./Picture 4.01

Messbereich Measuring Range	Innen Ø I.D. Ø 30 -185 mm	Außen Ø O.D. Ø 0 – 155 mm
Inhalt Basistisch C2 AL Base Content of basic table C2 AL Base	Messtisch mit 2 Klemmstücken CO-CP, 1 Messeinsatz-Halter CO-MH38 und 1 Messeinsatz-Halter CO-MH75 Measuring Table with 2 Clamping Pins CO-CP, 1 Measuring Contact Support CO-MH38 and 1 Measuring Contact Support CO-MH75	
Inhalt Messtisch C2 AL Content of gauge C2 AL	Wie C2 AL Base, zusätzlich mit 1 Messeinsatz-Halter CO-MH110, 1 Messeinsatz CO-MI16-25 und 2 Messeinsätzen CO-MI16-52 As C2 AL Base, additionally with 1 Measuring Contact Support CO-MH110, 1 Measuring Support CO-MI16-25 and 2 Measuring Contacts CO-MI16-52	

#### DIA-COME C2 JS

Abb./Picture 5.02

Messbereich Measuring Range	Innen Ø I.D. Ø 30 -275 mm	Außen Ø O.D. Ø 0 – 245 mm
Inhalt Basistisch C2 JS Base Content of basic table C2 JS Base	Messtische mit 1 Klemmstück CO-CP und 1 Messeinsatz-Halter CO-MH60 Measuring Table with 1 Clamping Pin CO-CP and 1 Measuring Contact Support CO-MH60	
Inhalt Messtisch C2 JS Content of gauge C2 JS	Wie C2 JS Base, zusätzlich mit 1 Messeinsatz CO-MI16-25 und 2 Messeinsätzen CO-MI16-52 As C2 JS Base, additionally with 1 Measuring Support CO-MI16-25 and 2 Measuring Contacts CO-MI16-52	

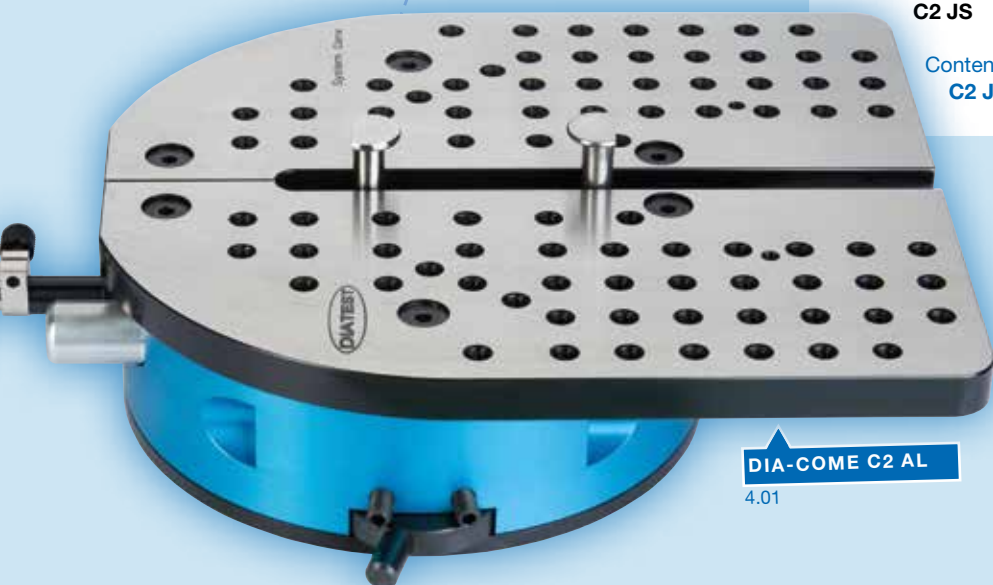

DIA-COME C2 AL

4.01



## DIA-COME C2 Kits für Ø (Bohrungsmessungen)

### DIA-COME C2 Kits for Ø (Bore Gauging)

DIA-COME Kits sind nur ein Mal pro passenden Messtisch und bei gleichzeitiger Bestellung eines solchen erwerbbar.

Zum Messen kleiner Durchmesser  
For the measurement of Small Diameters

C2-Kit1 / C2-Kit1-S		
Messbereich Measuring Range	Innen Ø I.D. Ø	Außen Ø O.D. Ø
	11,5 -60 mm	0 – 90 mm
Inhalt C2-Kit1 / C2-Kit1-S *	1 Klemmstück CO-CP, 1 Messeinsatz-Halter CO-MH38-S, 2 Messeinsätze CO-MI5-48-S, 2 Adapter CO-A44-S, 1 Paar Aufsatzplatten CO-MT-S und 4 Schrauben	
Content of C2-Kit1 / C2-Kit1-S *	1 Clamping Pin CO-CP, 1 Measuring Contact Support CO-MH38-S, 2 Measuring Supports CO-MI5-48-S, 2 Adapters CO-A44-S, 1 set of Small Tables CO-MT-S and 4 Screws	
Gültig für/ Valid for	alle C2 /all C2	

\*) DIA-COME Kits mit der Endung -S (Single) können einzeln erworben werden

\*) DIA-COME Kits with the ending -S (Single) can be acquired single

DIA-COME Kits can only be purchased once per suitable table and in combination with a suitable table.

Zum Messen großer Durchmesser  
For the measurement of Large Diameters

C2-Kit2		
Messbereich Measuring Range	Innen Ø I.D. Ø	Außen Ø O.D. Ø
	30 - 120 mm	0 – 100 mm
Inhalt C2-Kit2	1 Klemmstück CO-CP, 1 Messeinsatz-Halter CO-MH110	
Content of C2-Kit2	1 Clamping Pin CO-CP, 1 Measuring Contact Support CO-MH110	
Gültig für/ Valid for	alle C2 /all C2	

Zum Messen von Sacklochbohrungen  
For Flat Bottom

C2-Kit3		
Messbereich Measuring Range	Innen Ø I.D. Ø	Außen Ø O.D. Ø
	25 -105 mm	0 – 90 mm
Inhalt C2-Kit3	1 Messeinsatz CO-MI10-25-FB und 2 Messeinsätze CO-MI10-52-FB	
Content of C2-Kit3	1 Measuring Contact CO-MI10-25-FB, 2 Measuring Contacts CO-MI10-52-FB	
Gültig für/ Valid for	alle C2 /all C2	

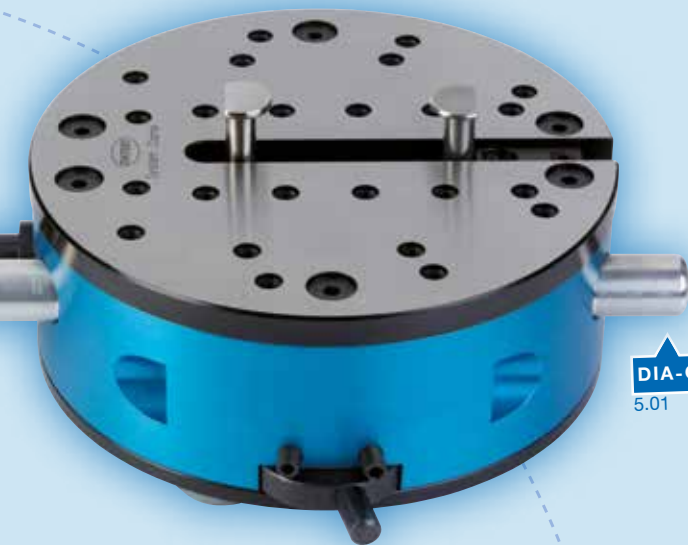

DIA-COME C2  
5.01

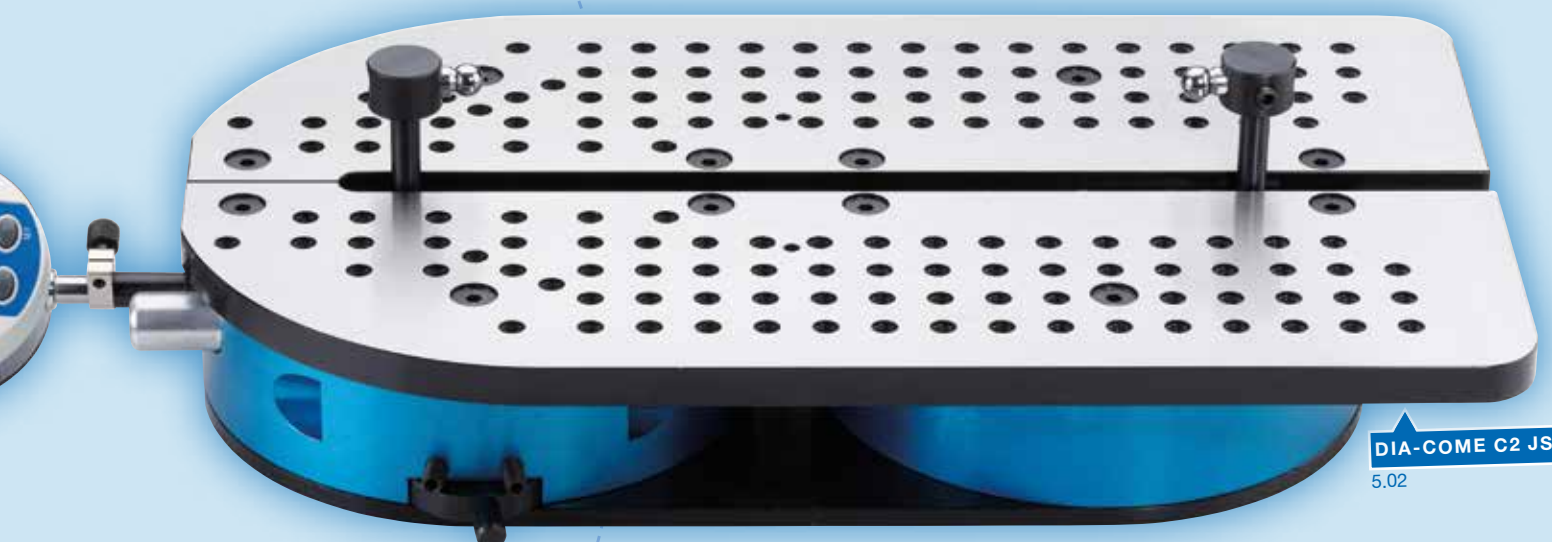

DIA-COME C2 JS  
5.02

# DIA-COME C2 Messtische für Verzahnung

## DIA-COME C2 Measuring Tables for Gear Gauges

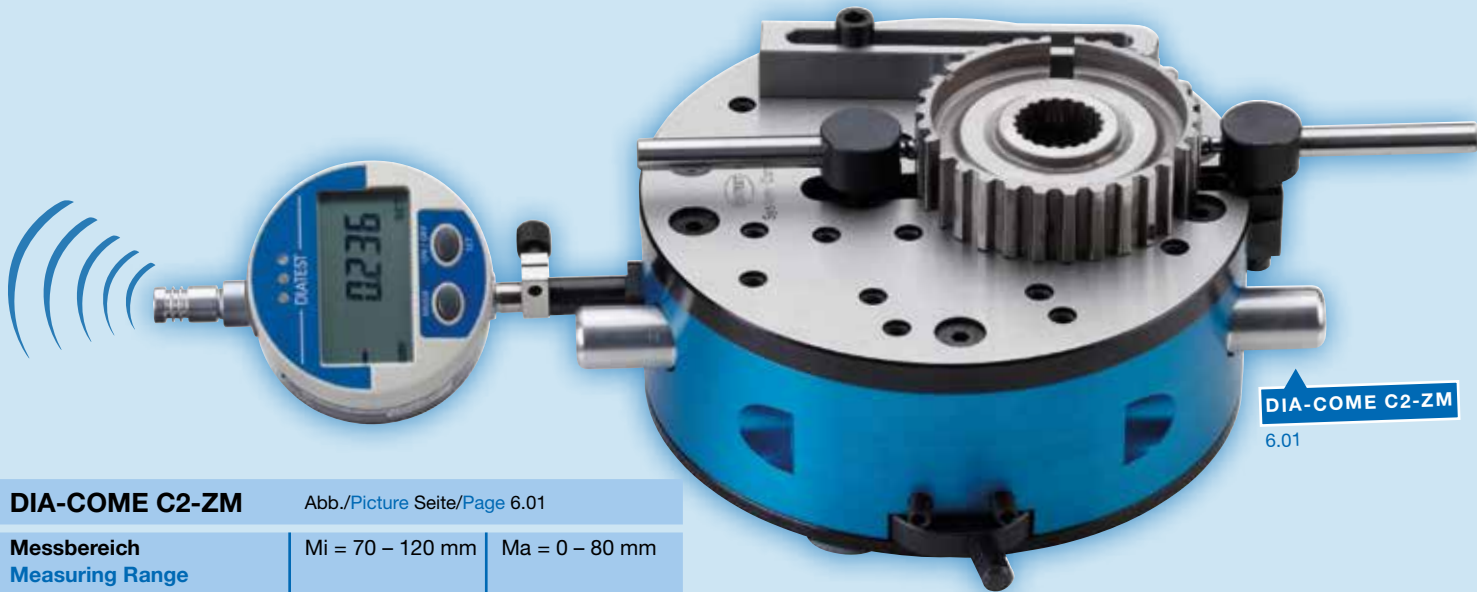

**DIA-COME C2-ZM**  
6.01

<b>DIA-COME C2-ZM</b> Abb./Picture Seite/Page 6.01	
<b>Messbereich</b> <b>Measuring Range</b>	Mi = 70 – 120 mm   Ma = 0 – 80 mm
<b>Inhalt Messtisch</b> <b>C2-ZM</b>	Wie C2 Base (Seite 4), zusätzlich mit 1 Fixem Anschlag CO-ST100, 2 Kugelstifträgern CO-ZMS30; zusätzlich benötigt: 2 Kugelmesseinsätze CO-MI8-KE (Kugel-Ø angeben)
<b>Content of basic table</b> <b>C2-ZM</b>	Content of gauge: As C2 Base (page 4), additionally with 1 Fixed Stop CO-ST100, 2 Supports for Gear Gauges CO-ZMS30; additionally needed: 2 Ball-Measuring Contacts (ball-Ø needed)

<b>DIA-COME C2-ZM AL</b> ohne Abb./ w/o Picture	
<b>Messbereich</b> <b>Measuring Range</b>	Mi = 70 – 195 mm   Ma = 0 – 155 mm
<b>Inhalt Messtisch</b> <b>C2-ZM AL</b>	Wie C2 AL Base (Seite 4, ohne CO-MH75), zusätzlich mit 1 Fixem Anschlag CO-ST100, 1 Messeinsatzhalter CO-MH110, 2 Kugelstifträgern CO-ZMS30; zusätzlich benötigt: 2 Kugelmesseinsätze CO-MI8-KE (Kugel-Ø angeben)
<b>Content of basic table</b> <b>C2-ZM AL</b>	Content of gauge: As C2 AL Base (page 4, w/o CO-MH75), additionally with 1 Fixed Stop CO-ST100, 1 Measuring Contact Support CO-MH110, 2 Supports for Gear Gauges CO-ZMS30; additionally needed: 2 Ball-Measuring Contacts (ball-Ø needed)



<b>DIA-COME C2-ZM JS</b> Abb./Picture Seite/Page 7.01	
<b>Messbereich</b> <b>Measuring Range</b>	Mi = 70 – 275 mm   Ma = 0 – 245 mm
<b>Inhalt Messtisch</b> <b>C2-ZM JS</b>	Inhalt Messtisch. Wie C2 JS Base (Seite 4), zusätzlich mit 1 Fixem Anschlag CO-ST100, 2 Kugelstifträgern CO-ZMS30; zusätzlich benötigt: 2 Kugelmesseinsätze CO-MI8-KE (Kugel-Ø angeben)
<b>Content of basic table</b> <b>C2-ZM JS</b>	Content of gauge: As C2 JS Base (page 4), additionally with 1 Fixed Stop CO-ST100, 2 Supports for Gear Gauges CO-ZMS30; additionally needed: 2 Ball-Measuring Contacts (ball-Ø needed)



## DIA-COME C2 Kits für Verzahnung

### DIA-COME C2 Kits for Gear Gauges

#### Kleine Werkstücke Small work pieces

C2-ZM Kit1 / C2-ZM Kit1-S		
Messbereich Measuring Range	Mi = 18 – 120 mm	Ma = 0 – 80 mm
Inhalt <b>C2-ZM Kit1</b> <b>C2-ZM Kit1-S *</b>	1 Messeinsatzhalter CO-MH38-S, 2 Adapter CO-A44-S, 2 Halter für Kugelschrauben für kleine Verzahnungen CO-ZMS45-S, 1 Set Aufsatzplatten für kleine Werkstücke CO-MT-S C2 Set, 1 Klemmstück CO-CP, 4 Schrauben, 2 Kugelschrauben KS-ZM3-Ø (Kugel-Ø angeben)	
Content of <b>C2-ZM Kit1</b> <b>C2-ZM Kit1-S *</b>	1 Measuring Contact Support CO-MH38-S, 2 Adapters CO-A44-S, 2 Holder for Ball Anvils for Small Gears CO-ZMS45-S, 1 Set Small Tables for Small Components CO-MT-S C2 Set, 1 Clamping Pin CO-CP, 4 Screws, 2 Ball Anvils KS-ZM3-Ø (Ball-Ø needed)	
Gültig für / Valid for	alle C2 / all C2	
*) DIA-COME Kits mit der Endung –S (Single) können einzeln erworben werden ) DIA-COME Kits with the ending –S (Single) can be acquired single		

#### Hohe Werkstücke High work pieces

C2-ZM Kit2		
Messbereich Measuring Range	Mi = 70 – 120 mm	Ma = 0 – 80 mm
Inhalt <b>C2-ZM Kit2</b>	2 Kugelstiftträger CO-ZMS52	
Content of <b>C2-ZM Kit2</b>	2 Supports for Gear Gauges CO-ZMS52	
Gültig für / Valid for	alle C2 / all C2	

Die Maße Mi und Ma sind abhängig von der Länge des Kugelstiftes. Die Standard-Länge beträgt 30 mm.  
Measurements Mi and Ma depend on length of ball pins. Standard length is 30 mm.

#### Höhenverstellbarer Anschlag Adjustable Stop

C2-ZM Kit3		
Messbereich Measuring Range	Mi = 70 – 120 mm	Ma = 0 – 80 mm
Inhalt <b>C2-ZM Kit3</b>	1 Verstellbarer Anschlag (Verstellbereich 28 mm) CO-STA50, 1 Fixe Anschlagstange mit Gewinde M2,5 CO-ST60-M2,5 (zum Einschrauben optionaler Einsätze, bspw. KS-MU)	
Content of <b>C2-ZM Kit3</b>	1 Adjustable Stop (Adjustment range 28 mm) CO-STA50, 1 Fixed Stop Bar with Thread M2.5 CO-ST60-M2,5 (for screwing optional inserts, e. g. KS-MU)	
Gültig für / Valid for	alle C2 / all C2	

#### Kugelschrauben Ball Anvils

C2-ZM Kit4		
Messbereich Measuring Range	Mi = 70 – 120 mm	Ma = 0 – 80 mm
Inhalt <b>C2-ZM Kit4</b>	2 Fixe Anschlagstangen mit Gewinde M2,5 CO-ST60-M2,5 (zum Einschrauben optionaler Einsätze, bspw. KS-MU)	
Content of <b>C2-ZM Kit4</b>	2 Fixed Stop Bars with Thread M2.5 CO-ST60-M2,5 (for screwing optional inserts, e.g. KS-MU)	
Gültig für / Valid for	alle C2 / all C2	

#### Sehr große Durchmesser Very Large Diameters

C2-ZM JS Kit1		
Messbereich Measuring Range	Mi = 70 – 300 mm	Ma = 0 – 275 mm
Inhalt <b>C2-ZM JS Kit1</b>	1 Messeinsatzhalter CO-MH110, 1 Klemmstück CO-CP	
Content of <b>C2-ZM JS Kit1</b>	1 Measuring Contact Support CO-MH110, 1 Clamping Pin CO-CP	
Gültig für / Valid for	nur C2 JS / only C2 JS	

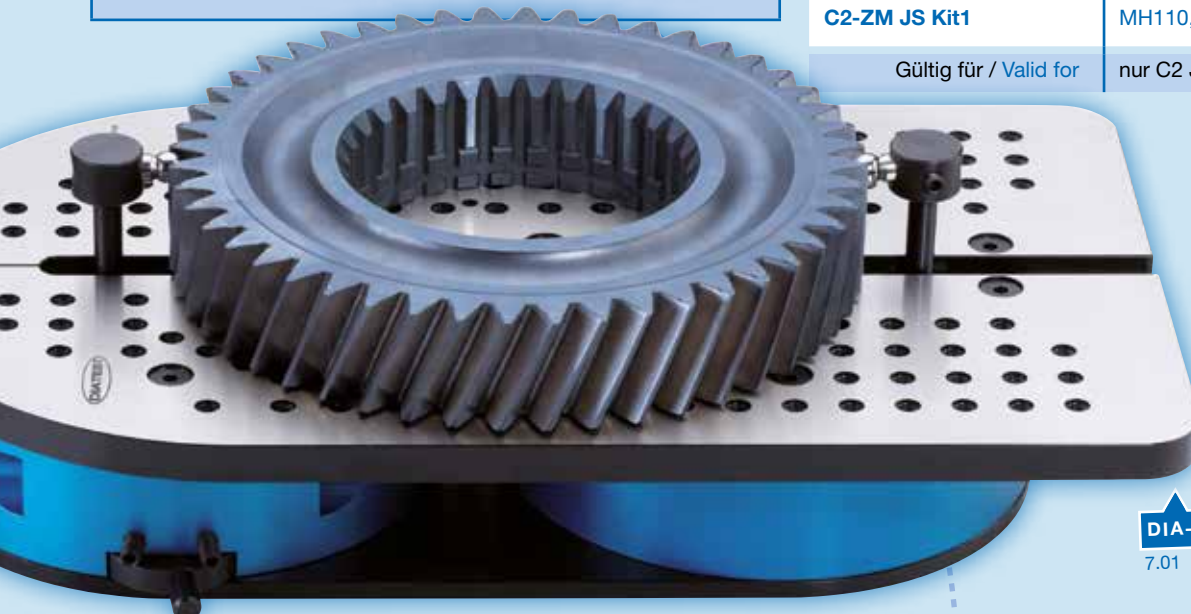

## DIA-COME Ausrichtung und Einstellmeister DIA-COME Adjustment and Setting Master

Z.B. Endmaß zur Ausrichtung  
der Höhe

e.g. Gauge Block for aligning  
the height

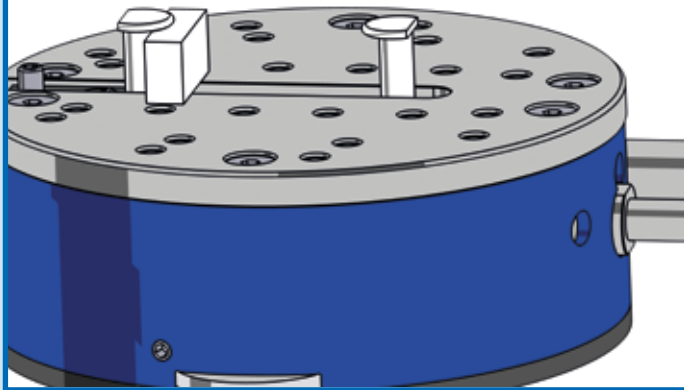

Messeinsätze müssen in Höhe und Abstand zueinander ausgerichtet werden, zudem muss der Messhub angepasst werden. Um Messeinsätze in der Höhe auszurichten, können z.B. Endmaße verwendet werden. Für die korrekte Anpassung des Abstands zwischen den Messeinsätzen und des Messhubs eignet sich am besten ein Einstellmeister.

Measuring contacts have to be adapted in height and distance to each other and the measuring stroke has to be aligned. To align heights of measuring contacts, you can use gauge blocks for instance. A setting master is the most appropriate gauge for correct adaptation of distance between measuring inserts and measuring stroke.

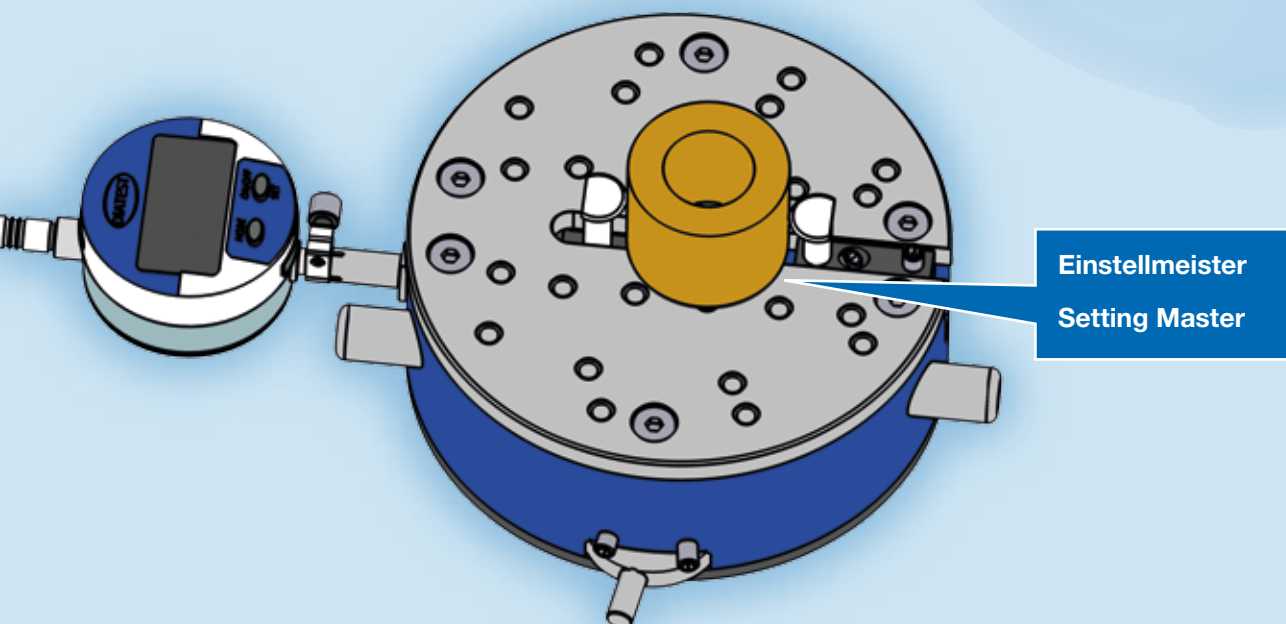

Einstellmeister  
Setting Master



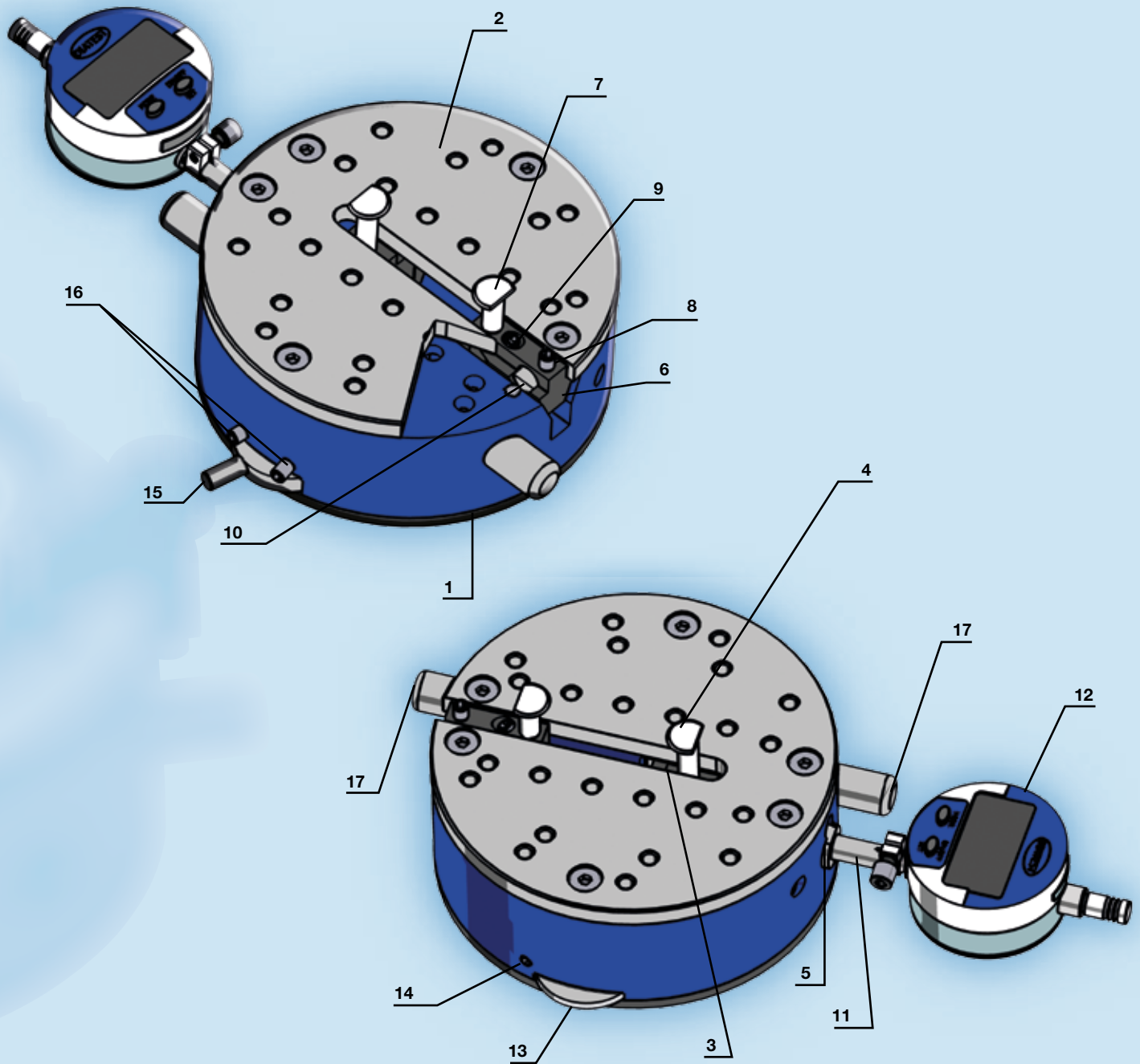

**DIA-COME Tische – Legende**

**DIA-COME tables – Legend**

- |   |  |
|---|--|
| 1. Grundkörper<br>body  | 10. Klemmstück CO-CP<br>clamping pin CO-CP   |
| 2. Tischplatte<br>table top   | 11. Einbauhalter<br>build-in holder  |
| 3. Messeinsatzhalter CO-MH, beweglich<br>measuring content support CO-MH, mobile          | 12. Messuhr oder -taster<br>dial indicator or probe  |
| 4. Messeinsatz CO-MI, beweglich<br>measuring insert CO-MI, mobile                         | 13. Stellrad für Messrichtung und Messkraft (für CO-MI Nr. 4)<br>setting wheel for measuring direction and force (for CO-MI no. 4) |
| 5. Klemmschraube zum Arretieren des CO-MI (Nr. 4)<br>stop screw to lock CO-MI (no. 4)     | 14. Klemmschraube zum Arretieren des Stellrads (Nr. 13)<br>clamping screw to lock setting wheel (no. 13)                           |
| 6. Messeinsatzhalter CO-MH, fest<br>measuring contact support CO-MH, fixed                | 15. Anlühthebel für CO-MI (Nr. 4)<br>retracting lever for CO-MI (no. 4)  |
| 7. Messeinsatz CO-MI, fest<br>measuring insert CO-MI, fixed                               | 16. Anschlagsschrauben zur Messbereichsbegrenzung (für Nr. 15)<br>stop screws to limit measuring range (for no. 15)                |
| 8. Klemmschraube zum Arretieren des CO-MH (Nr. 6)<br>clamping screw to lock CO-MH (no. 6) | 17. Verschlusskappen<br>sealing caps   |
| 9. Klemmschraube zum Arretieren des CO-MI (Nr. 7)<br>clamping screw to lock CO-MI (no. 7) |  |

Messen eines Außendurchmessers  
Measuring of an outer diameter

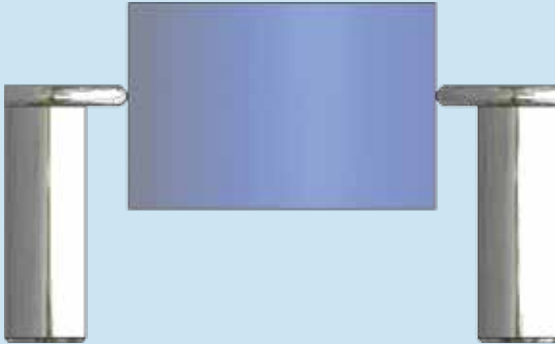

Messen des Durchmessers einer Außennut  
Measuring of an outer groove diameter

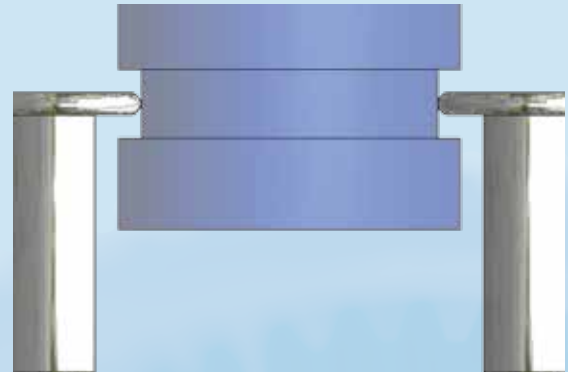

Messen der Konizität  
Measuring of the taper

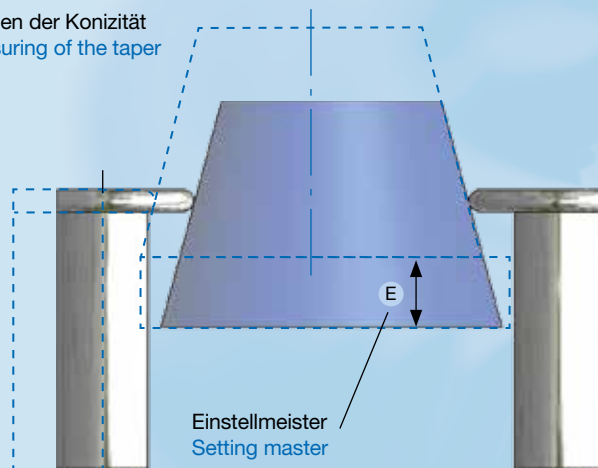

Messen einer Innenverzahnung  
Inside gear gauge measurement

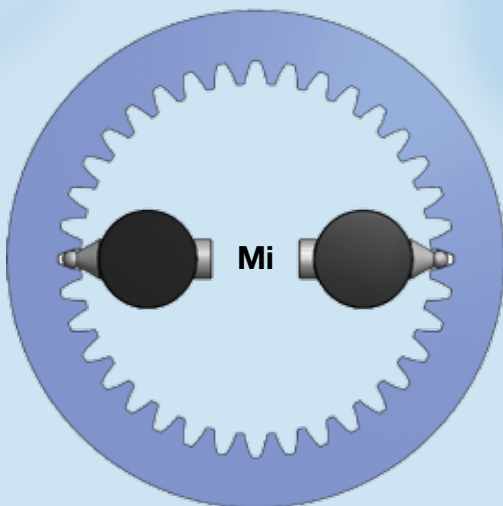

Messen einer Außenverzahnung  
Outside gear gauge measurement

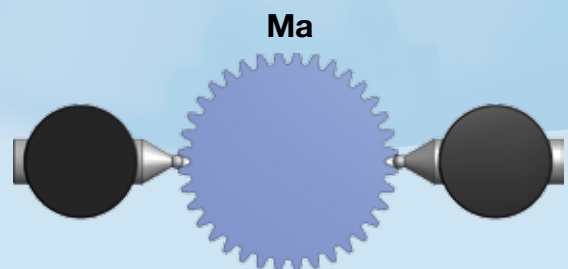

Messen eines Innendurchmessers  
Measurement of an inside diameter

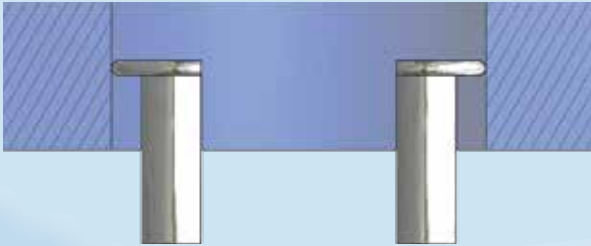

Messen einer Innennut  
Measurement of an inside groove



Messen eines Sacklochs  
Flat Bottom measurement



Messen eines schwer zugänglichen Durchmesser  
(Innen- oder Außendurchmesser)  
Measurement of a diameter which is difficult to reach (I.D. or O.D.)

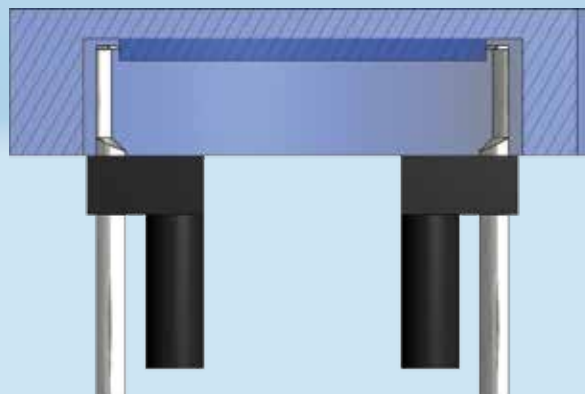

## DIA-COME C3 Messtische

### DIA-COME C3 Measuring Tables

Die DIA-COME C3 Messtische sind in vier Größen verfügbar und decken unterschiedliche Messbereiche ab. C3 Messtische haben einen beweglichen und zwei feste Messkontakte. Durch die variable Montage der festen Messkontakte erfolgt die Anpassung auf das gewünschte Maß. Der bewegliche Messkontakt hat einen Messbereich von 20 mm. Der Messweg wird direkt 1:1 auf eine Messwertanzeige übertragen.

Alle Messtische sind als Basistische ohne Messkontakte und als vollwertige Messtische mit Messkontakten erwerbbar. C3 Messtische sind auch mit Zoll-Klemmung erhältlich.

DIA-COME C3 measuring tables are available in 4 sizes which cover different measuring ranges. C3 measuring tables have two fixed and one moving measuring contact. The required measurement can be achieved by fitting the fixed measuring contacts. The moveable measuring contact has a measuring range of 20 mm. The measuring travel is transferred 1:1 to the measuring indicator.

All measuring tables are available as basic tables ("Base") without measuring contacts, or as fully complete measuring tables including measuring contacts. C3 measuring tables are also available with 3/8" clamping.

<b>DIA-COME C3-90</b>		Abb./Picture 13.02
<b>Messbereich</b> <b>Measuring Range</b>	Innen Ø I.D. Ø 35 – 80 mm	Außen Ø O.D. Ø 0 – 60 mm
Inhalt Basistisch <b>C3-90 Base</b> Content of basic table <b>C3-90 Base</b>	Messtisch mit 2 Klemmstücken, CO-CP 2 Messeinsatzhalter CO-MH38 Measuring Table with 2 Clamping Pins CO-CP, 2 Measuring Contact Supports CO-MH38	
Inhalt Messtisch <b>C3-90</b> Content of basic table <b>C3-90</b>	Wie C3-90 Base, zusätzlich mit 1 Messeinsatz CO-MI10,5-52 und 2 Messeinsätzen CO-MI10,5-36 As C3-90 Base, additionally with 1 Measuring Contact CO-MI10-52, 2 Measuring Contacts CO-MI10-36	

<b>DIA-COME C3-45</b>		Abb./Picture 13.03
<b>Messbereich</b> <b>Measuring Range</b>	Innen Ø I.D. Ø 40 – 100 mm	Außen Ø O.D. Ø 0 – 80 mm
Inhalt Basistisch <b>C3-45 Base</b> Content of basic table <b>C3-45 Base</b>	Messtisch mit 2 Klemmstücken, CO-CP 2 Messeinsatzhalter CO-MH38 Measuring Table with 2 Clamping Pins CO-CP, 2 Measuring Contact Supports CO-MH38	
Inhalt Messtisch <b>C3-45</b> Content of basic table <b>C3-45</b>	Wie C3-45 Base, zusätzlich mit 1 Messeinsatz CO-MI10,5-52 und 2 Messeinsätzen CO-MI10,5-36 As C3-45 Base, additionally with 1 Measuring Contact CO-MI10-52, 2 Measuring Contacts CO-MI10-36	

<b>DIA-COME C3-AL</b>		Abb./Picture 13.04
<b>Messbereich</b> <b>Measuring Range</b>	Innen Ø I.D. Ø 40 – 140 mm	Außen Ø O.D. Ø 0 – 110 mm
Inhalt Basistisch <b>C3-AL Base</b> Content of basic table <b>C3-AL Base</b>	Messtisch mit 3 Klemmstücken, CO-CP 2 Messeinsatzhalter CO-MH38 und 1 Messeinsatzhalter CO-MH75 Measuring Table with 3 Clamping Pins CO-CP, 2 Measuring Contact Supports CO-MH38, 1 Measuring Contact Support CO-MH75	
Inhalt Messtisch <b>C3-AL</b> Content of basic table <b>C3-AL</b>	Wie C3-AL Base, zusätzlich mit 1 Messeinsatz CO-MI16-52, 2 Mes- seinsätze CO-MI16-36, 1 Messeins- atzhalter CO-MH110 As C3-AL Base, additionally with 1 Measuring Contact CO-MI16-52, 2 Measuring Contacts CO-MI16-36, 1 Measuring Contact Support CO- MH110	



<b>DIA-COME C3-JS</b>		Abb./Picture 13.01
<b>Messbereich</b> <b>Range of basic gauge</b>	Innen Ø I.D. Ø 40 – 220 mm	Außen Ø O.D. Ø 0 – 170 mm
Inhalt Basistisch <b>C3-JS Base</b> Content of basic table <b>C3-JS Base</b>	Messtisch mit 3 Klemmstücken, CO-CP 2 Messeinsatzhalter CO-MH60 Measuring Table with 3 Clamping Pins, 2 Measuring Contact Supports CO-MH60	
Inhalt Messtisch <b>C3-JS</b> Content of basic table <b>C3-JS</b>	Wie C3-JS Base, zusätzlich mit 1 Messeinsatz CO-MI16-52, 2 Mes- seinsätze CO-MI16-36, 1 Messeins- atzhalter CO-MH110, 1 Messeinsatz- halter CO-MH38 As C3-JS Base, additionally with 1 Measuring Contact CO-MI16-52, 2 Measuring Contacts CO-MI16-36, 1 Measuring Contact Support CO-MH110, 1 Measuring Contact Support CO-MH38	

<b>DIA-COME C3-JSL</b>		ohne Abb./ w/o Picture
<b>Messbereich Basisgerät</b> <b>Range of basic gauge</b>	Innen Ø I.D. Ø 30 – 275 mm	Außen Ø O.D. Ø 0 – 245 mm
Inhalt Basistisch <b>C3-JSL Base</b> Content of basic table <b>C3-JSL Base</b>	Messtisch mit 3 Klemmstücken CO-CP, 1 Messeinsatzhalter CO-MH60, 1 Mes- seinsatzhalter CO-MH75 Measuring Table with 3 Clamping Pins CO-CP, 1 Measuring Contact Support CO-MH60, 1 Measuring Contact Support CO-MH75	
Inhalt Messtisch <b>C3-JSL</b> Content of basic table <b>C3-JSL</b>	Wie C3-JSL Base, zusätzlich mit 1 Messeinsatz CO-MI16-52, 2 Messeinsätze CO-MI16-36 As C3-JSL Base, additionally with 1 Measuring Contact CO-MI16-52, 2 Measuring Contacts CO-MI16-36	

## DIA-COME C3 Kits

### DIA-COME C3 Kits

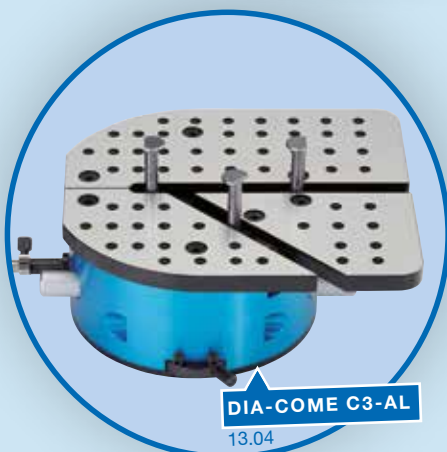
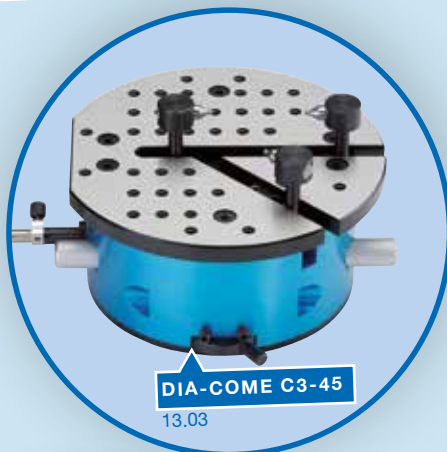
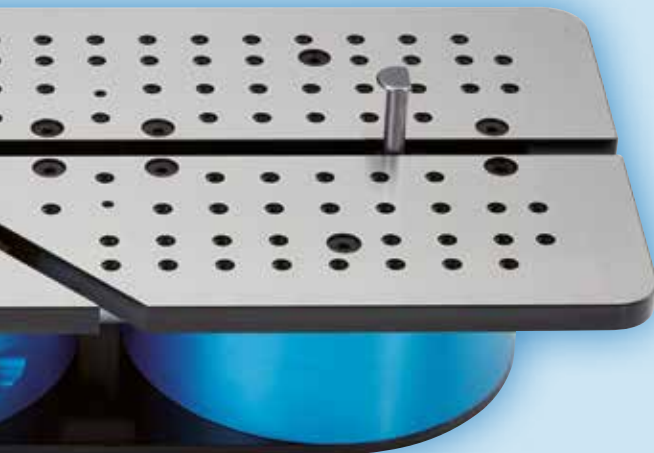
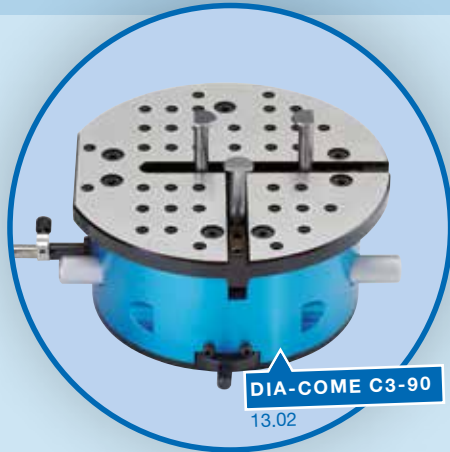

Zum Messen kleiner Durchmesser  
For the measurement of Small Diameters

#### C3-Kit1 / C3-Kit1-S

Messbereich Measuring Range	Innen Ø I.D. Ø 20 – 35 mm	Außen Ø O.D. Ø 0 – 60 mm
Inhalt <b>C3- Kit1</b> <b>C2- Kit1-S *</b>	2 Klemmstücke CO-CP, 2 Messeinsatz-Halter CO-MH38-S, 3 Messeinsätze CO-MI5-48-S, 3 Adapter CO-A29-S, 1 Set Aufsatzplatten CO-MT-S-C3 Set und 5 Schrauben	
Content of <b>C3- Kit1</b> <b>C2- Kit1-S *</b>	2 Clamping Pins CO-CP, 1 Set of Small Tables CO-MT-S C3 Set, 2 Measuring Contact Supports CO-MH38-S, 3 Adapter CO-A29-S, 3 Measuring Contacts CO-MI5-48-S, 5 Screws	
Gültig für/ Valid for	alle C2 /all C2	
*) DIA-COME Kits mit der Endung –S (Single) können einzeln erworben werden		
*) DIA-COME Kits with the ending –S (Single) can be acquired single		

Zum Messen von Einstichen bis zu 2,5 mm Tiefe  
For the measurement of Grooves up to a depth of 2.5 mm

#### C3-Kit2

Messbereich Measuring Range	Innen Ø I.D. Ø 28 – 80 mm	Außen Ø O.D. Ø 0 – 60 mm
Inhalt <b>C3-Kit2</b>	1 Messkontakt CO-MI8-45, 2 Messkontakte CO-MI8-36	
Content of <b>C3-Kit2</b>	1 Measuring Contact CO-MI8-45, 2 Measuring Contacts CO-MI8-36	
Gültig für/ Valid for	alle C2 /all C2	

Zum Messen großer Durchmesser  
For the measurement of Large Diameters

#### C3-Kit3

Messbereich Measuring Range	Innen Ø I.D. Ø 40– 250 mm	Außen Ø O.D. Ø 0 – 200 mm
Inhalt <b>C3-Kit3</b>	1 Klemmstück CO-CP, 1 Messeinsatz-Halter CO-MH150	
Content of <b>C3-Kit3</b>	1 Measuring Contact Support CO-MH150, 1 Clamping Pin CO-CP	
Gültig für/ Valid for	C3 JS, C3 JSL / C3 JS, C3 JSL	

### DIA-COME Messeinsatz-Halter

Messeinsatz-Halter dienen der Aufnahme der Messeinsätze in den DIA-COME Tischen. Jeder Messeinsatz-Halter kann nur einen Messeinsatz aufnehmen. Messeinsatzhalter gibt es in verschiedenen Längen, dadurch können die Messbereiche der DIA-COME Tische angepasst werden.

### DIA-COME Measuring Contact Support

Measuring Contact Supports hold the Measuring Inserts inside the measuring tables. Each Measuring Contact Support can only hold one Measuring Insert. Measuring Contact Supports are available in different lengths, therefore the measuring range of a DIA-COME table can be adjusted as required

CO-MH38: Messeinsatz-Halter L=38 mm  
CO-MH38: Measuring Contact Support L=38 mm

Abb./Picture  
14.01

CO-MH60: Messeinsatz-Halter L=60 mm  
CO-MH60: Measuring Contact Support L=60 mm

Abb./Picture  
14.02

CO-MH75: Messeinsatz-Halter L=75 mm  
CO-MH75: Measuring Contact Support L=75 mm

Abb./Picture  
14.03

CO-MH110: Messeinsatz-Halter L=110 mm  
CO-MH110: Measuring Contact Support L=110 mm

CO-MH150: Messeinsatz-Halter L=150 mm  
CO-MH150: Measuring Contact Support L=150 mm

CO-MH38-S: Messeinsatz-Halter, L=38 mm, gestuft, Bei Verwendung der Adapter CO-A29-S und CO-A44-S

Abb./Picture  
14.04

CO-MH38-S: Measuring Contact Support L = 38 mm, stepped, when using the adapter CO-A29-S and CO-A44-S

### DIA-COME Klemmstück

Mit den Klemmstücken werden die Messeinsatz-Halter im Tisch fixiert. In Abhängigkeit vom Messeinsatz-Halter werden ein oder zwei Klemmstücke benötigt.

### DIA-COME Clamping Pin

Clamping Pins hold the Measuring Contact Supports inside the table. Depending on the Measuring Contact Support one or two Clamping Pins are needed.

CO-CP Klemmstück für Messeinsatz-Halter  
CO-CP: Clamping Pin for Measuring Contact Support

Abb./Picture  
14.05

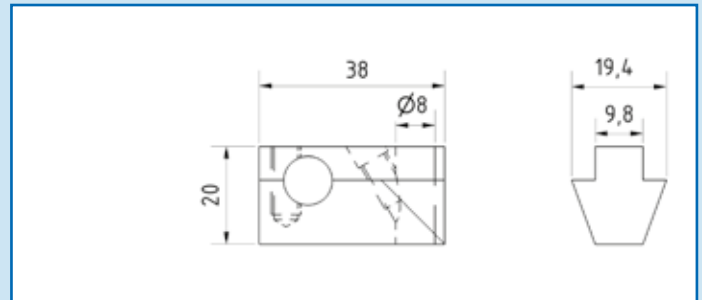

14.01

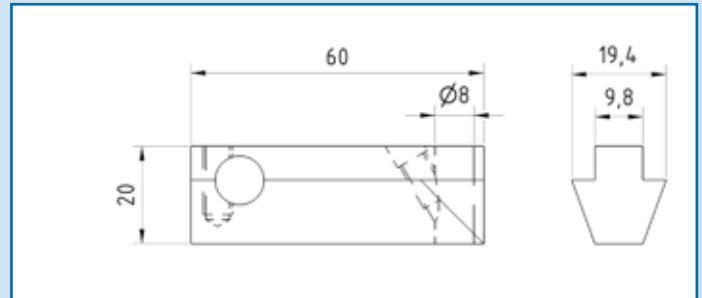

14.02

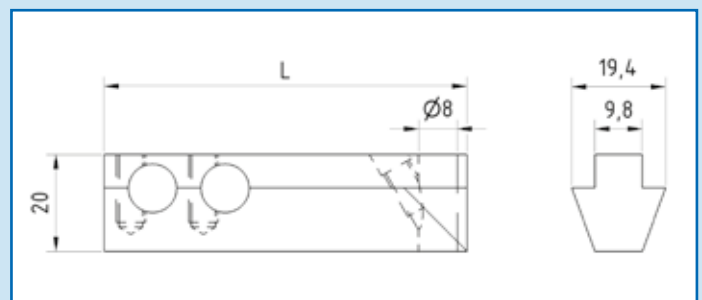

14.03

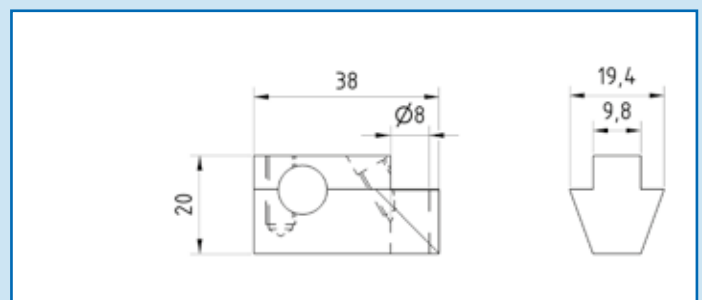

14.04

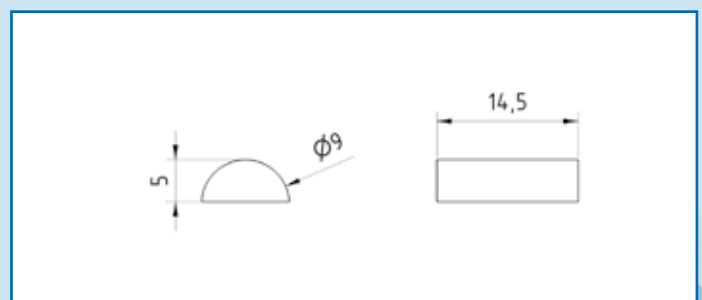

14.05

### Für Innen- und Außendurchmesser

Für unterschiedlichste Messaufgaben kann man unter einer Vielzahl von Messeinsätzen wählen.

### For Inner- and Outer diameter

For different applications you can choose between a wide range of Measuring Inserts.

CO-MI10,5-36 Messeinsatz,  $\varnothing=10,5\text{mm}$ ,  $L=36\text{ mm}$  Abb./Picture  
CO-MI10,5-36 Measuring Insert,  $\varnothing=10.5\text{mm}$ ,  $L=36\text{ mm}$  15.01

CO-MI10,5-52 Messeinsatz,  $\varnothing=10,5\text{mm}$ ,  $L=52\text{ mm}$   
CO-MI10,5-52 Measuring Insert,  $\varnothing=10.5\text{mm}$ ,  $L=52\text{ mm}$

CO-MI16-25 Messeinsatz,  $\varnothing=16\text{mm}$ ,  $L=25\text{ mm}$  Abb./Picture  
CO-MI16-25 Measuring Insert,  $\varnothing=16\text{mm}$ ,  $L=25\text{ mm}$  15.02

CO-MI16-36 Messeinsatz,  $\varnothing=16\text{mm}$ ,  $L=36\text{ mm}$   
CO-MI16-36 Measuring Insert,  $\varnothing=16\text{mm}$ ,  $L=36\text{ mm}$

CO-MI16-52 Messeinsatz,  $\varnothing=16\text{mm}$ ,  $L=52\text{ mm}$   
CO-MI16-52 Measuring Insert,  $\varnothing=16\text{mm}$ ,  $L=52\text{ mm}$

CO-MI16-67 Messeinsatz,  $\varnothing=16\text{mm}$ ,  $L=67\text{ mm}$   
CO-MI16-67 Measuring Insert,  $\varnothing=16\text{mm}$ ,  $L=67\text{ mm}$

CO-MI16-82 Messeinsatz,  $\varnothing=16\text{mm}$ ,  $L=82\text{ mm}$   
CO-MI16-82 Measuring Insert,  $\varnothing=16\text{mm}$ ,  $L=82\text{ mm}$

CO-MI16-120 Messeinsatz,  $\varnothing=16\text{mm}$ ,  $L=120\text{ mm}$   
CO-MI16-120 Measuring Insert,  $\varnothing=16\text{mm}$ ,  $L=120\text{ mm}$

CO-MI24-25 Messeinsatz,  $\varnothing=24\text{mm}$ ,  $L=25\text{ mm}$  Abb./Picture  
CO-MI24-25 Measuring Insert,  $\varnothing=24\text{mm}$ ,  $L=25\text{ mm}$  15.03

CO-MI24-52 Messeinsatz,  $\varnothing=24\text{mm}$ ,  $L=52\text{ mm}$   
CO-MI24-52 Measuring Insert,  $\varnothing=24\text{mm}$ ,  $L=52\text{ mm}$

CO-MI28-25 Messeinsatz,  $\varnothing=28\text{mm}$ ,  $L=25\text{ mm}$  Abb./Picture  
CO-MI28-25 Measuring Insert,  $\varnothing=28\text{mm}$ ,  $L=25\text{ mm}$  15.04

CO-MI28-52 Messeinsatz,  $\varnothing=28\text{mm}$ ,  $L=52\text{ mm}$   
CO-MI28-52 Measuring Insert,  $\varnothing=28\text{mm}$ ,  $L=52\text{ mm}$

CO-MI28-82 Messeinsatz,  $\varnothing=28\text{mm}$ ,  $L=82\text{ mm}$   
CO-MI28-82 Measuring Insert,  $\varnothing=28\text{mm}$ ,  $L=82\text{ mm}$

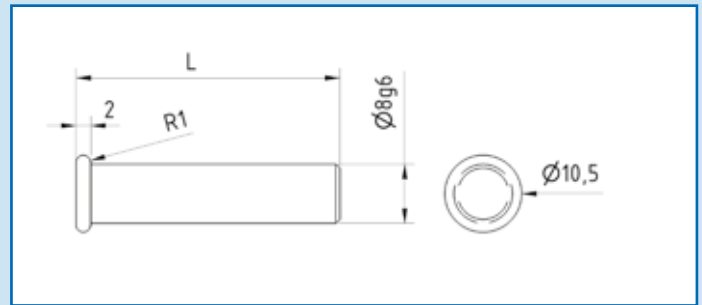

15.01

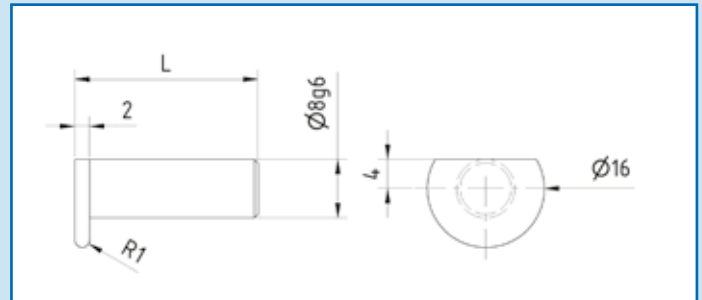

15.02

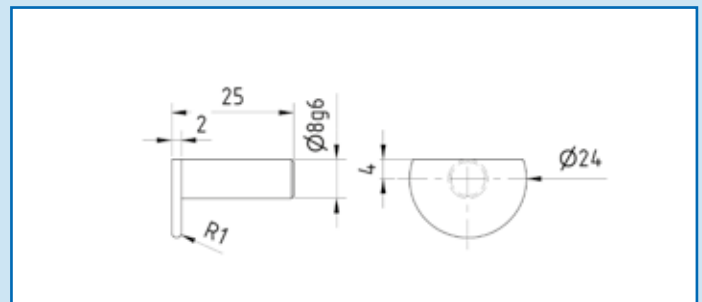

15.03

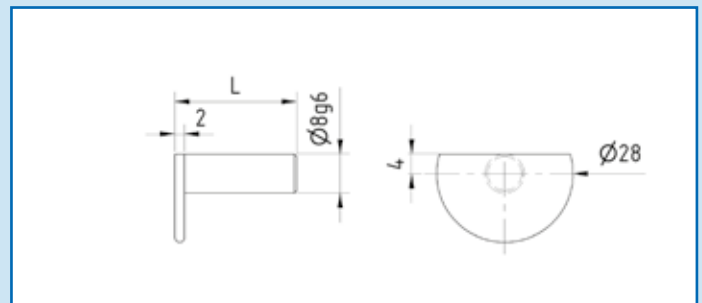

15.04

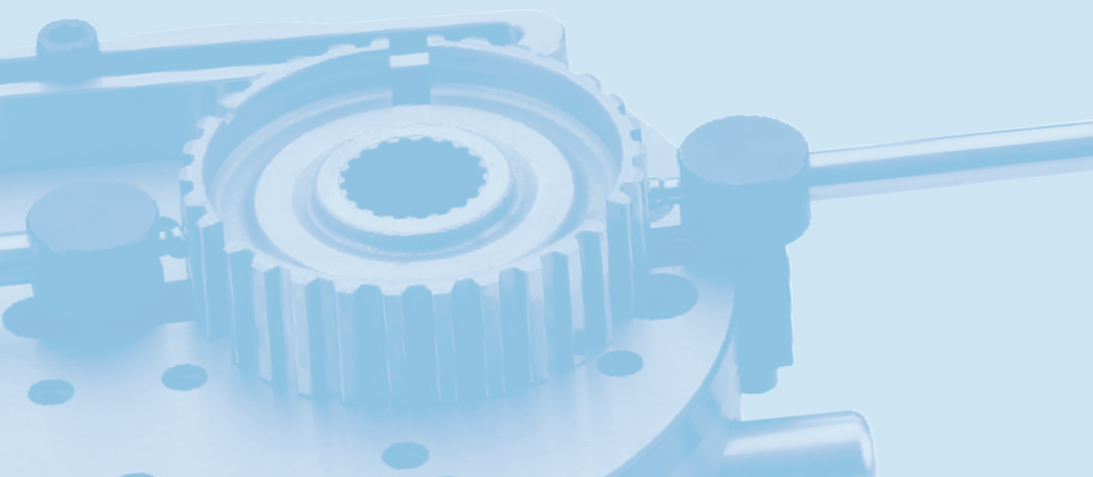

Für beide Messaufgaben kann man unterschiedliche Messeinsätze wählen.

For both measuring tasks you can choose between different measuring inserts.

### Für Einstiche

#### For Grooves

CO-MI8-36;  $\varnothing$  8 mm, L=36 mm  
CO-MI8-36;  $\varnothing$  8 mm, L=36 mm

Abb./Picture  
16.01

CO-MI8-45;  $\varnothing$  8 mm, L=45 mm  
CO-MI8-45;  $\varnothing$  8 mm, L=45 mm

### Für Sacklochbohrungen

#### For Flat Bottom

CO-MI10-25-FB;  $\varnothing$ =10mm, L=25mm  
CO-MI10-25-FB;  $\varnothing$ =10mm, L=25mm

Abb./Picture  
16.02

CO-MI10-52-FB;  $\varnothing$ =10mm, L=52mm  
CO-MI10-52-FB;  $\varnothing$ =10mm, L=52mm

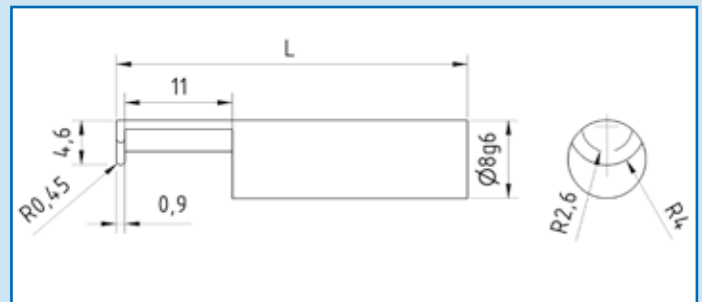

16.01

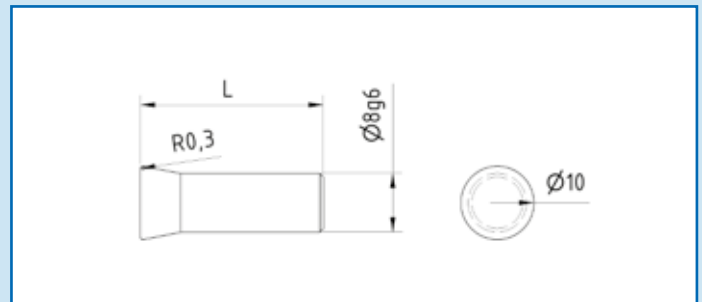

16.02

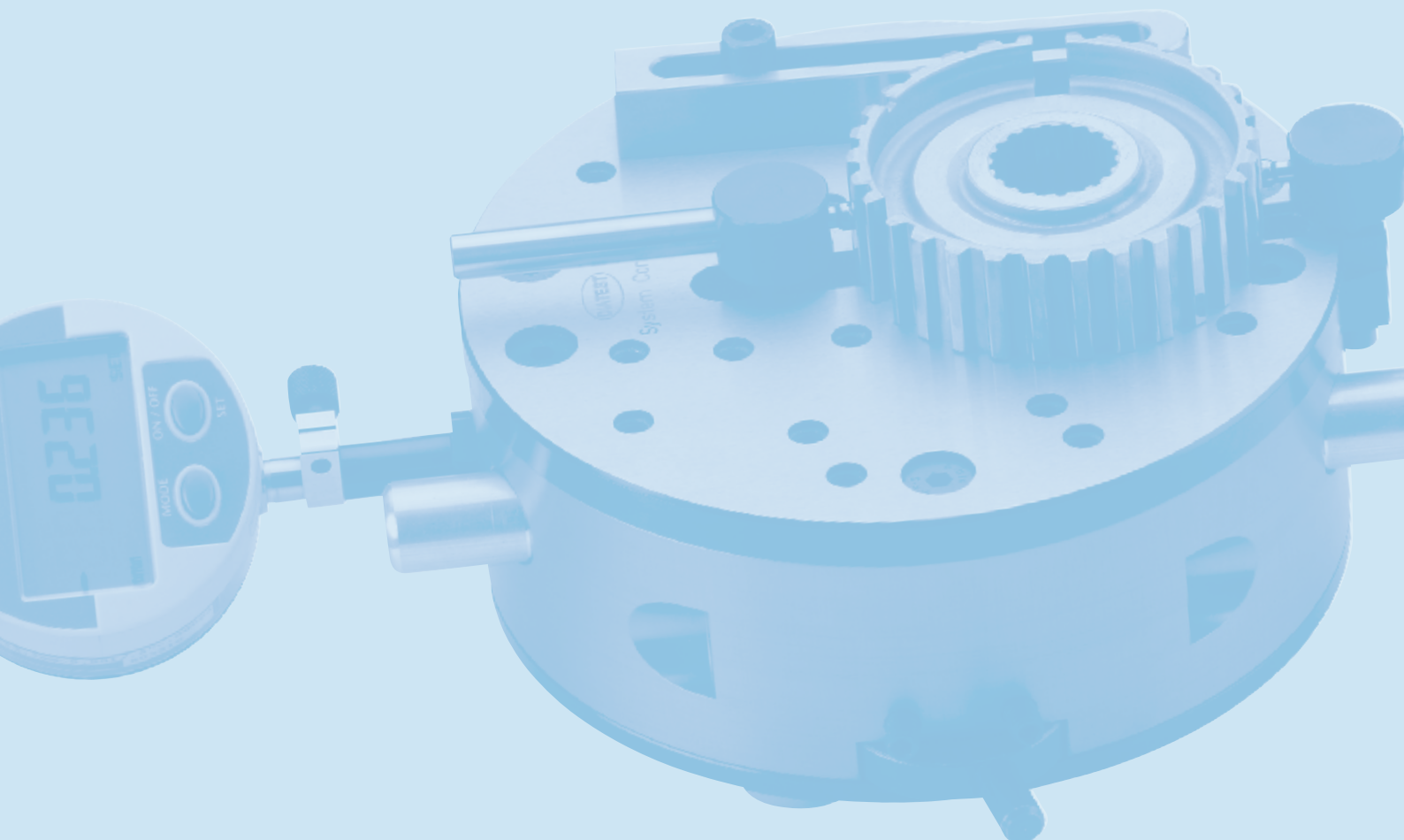



### DIA-COME Zwischenstück (Adapter)

Zwischenstücke dienen der Aufnahme von Messeinsätzen mit kleineren Schaft-Durchmessern (< 5 mm) Sie stellen damit das notwendige Bindeglied zum Messeinsatz-Halter für kleine Durchmesser dar.

### DIA-COME Adapter

Adapters are used for clamping the measuring inserts with small shaft diameters (< 5 mm). They are the required connectors to the Measuring Contact Supports for small diameters.

CO-A29-S Adapter, L=29mm, kurz  
CO-A29-S Adapter, L=29mm, short

Abb./Picture  
17.01

CO-A44-S Adapter, L=44mm  
CO-A44-S Adapter, L=44mm

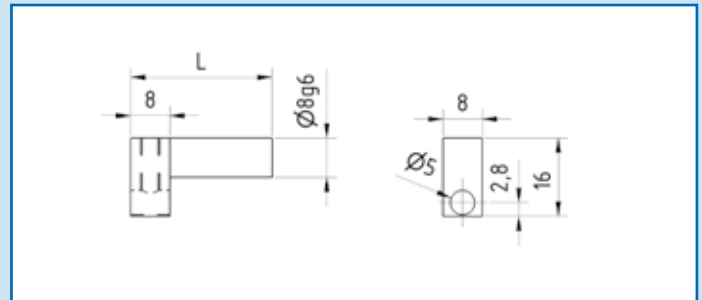

17.01

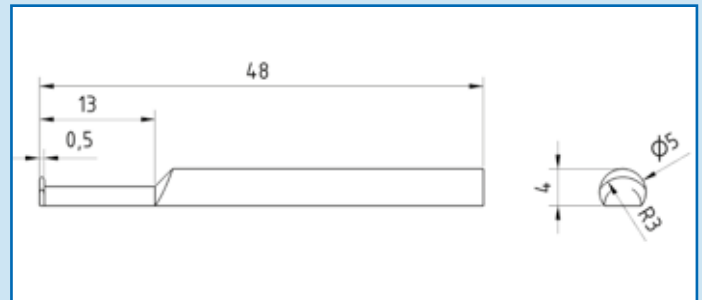

17.02

### Messeinsatz für besonders kleine Durchmesser

### Measuring Insert for Very Small Diameters

CO-MI5-48-S Messeinsatz, Ø=5mm, L=48mm  
CO-MI5-48-S Measuring Insert, Ø=5mm, L=48mm

Abb./Picture  
17.02

### DIA-COME Aufsatzplatte

Die Aufsatzplatten dienen der Verkleinerung der Tisch-Nut, wenn kleine Durchmesser gemessen werden sollen. Sie werden in Verbindung mit den Zwischenstücken (Adaptoren) eingesetzt.

### DIA-COME Small Table

The Small Tables have a smaller groove in the table top. They are used for the measurement of small diameters and in combination with the adapters.

CO-MT-S Aufsatzplatte für kleine Werkstücke,  
nur für C2 Tische Inkl. 2 Schrauben  
CO-MT-S Small Table for small components,  
only for C2 tables, incl. 2 screws

Abb./Picture  
17.03

CO-MT-S-C3 Aufsatzplatte für kleine Werkstücke,  
nur für C3 Tische Inkl. 3 Schrauben  
CO-MT-S-C3 Small Table for small components,  
only for C3 tables, incl. 3 screws

Abb./Picture  
17.04

CO-MT-S C2 Set, 2 CO-MT-S, nur C2 Tische;  
Inkl. 4 Schrauben  
CO-MT-S C2 Set, 2 CO-MT-S, only for C2 tables,  
incl. 4 screws

ohne Abb.  
w/o Picture

CO-MT-S C3 Set, 1 CO-MT-S und 1 CO-MT-S C3,  
nur C3 Tische Inkl. 5 Schrauben  
CO-MT-S C3 Set, 1 CO-MT-S und 1 CO-MT-S C3,  
only for C3, incl. 5 screws

ohne Abb.  
w/o Picture

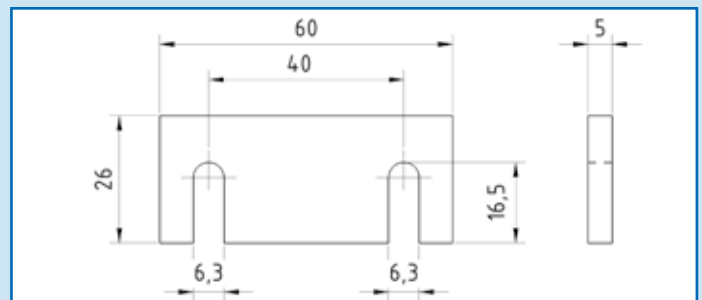

17.03

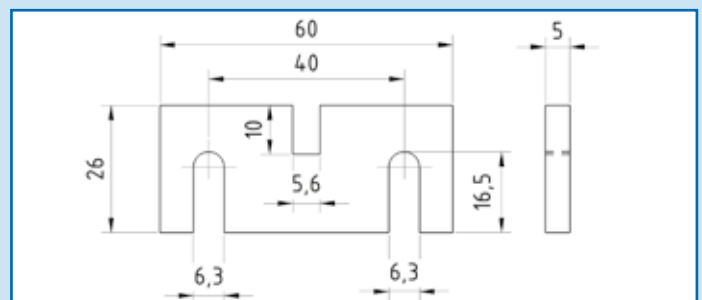

17.04

### DIA-COME Kugelstiftträger

Kugelstiftträger dienen der Aufnahme von Messeinsätzen für die Verzahnung, bspw. CO-MI8-KE.

### DIA-COME Support for Gear Gauging

The Support for Gear Gauges is for clamping the measuring inserts for gear gauges, e. g. CO-MI8-KE

CO-ZMS30 Halter für Verzahnung, L=30mm  
CO-ZMS30 Holder for ball anvils, L=30mm

Abb./Picture  
18.01

CO-ZMS52 Halter für Verzahnung, L=52mm  
CO-ZMS52 Holder for ball anvils, L=52mm

CO-ZMS45-S Halter für Kugelschrauben für kleine Verzahnungen, L=45 mm; zur Verwendung mit KS-ZM3 Messkontakten  
CO-ZMS45-S Holder for ball anvils for small gears, L = 45 mm. To use with KS-ZM3 measuring contacts.

Abb./Picture  
18.02

### Messeinsatz für Verzahnungen

### Measuring Insert for Gear Gauges

CO-MI8-KE Kugel-Messeinsatz,  $\varnothing=8\text{mm}$  (Schaft), für Verzahnung; Angabe Kugeldurchmesser notwendig  
CO-MI8-KE Ball Measuring Contact,  $\varnothing = 8 \text{ mm}$  (shaft) for Gear Gauges; specification of ball- $\varnothing$  is necessary

Abb./Picture  
18.03

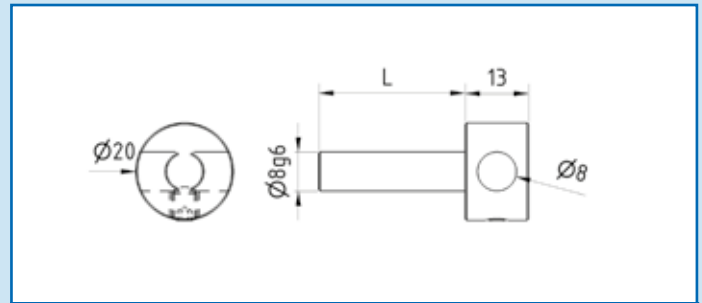

18.01

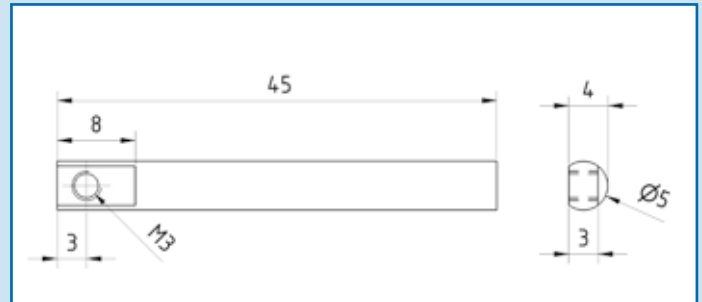

18.02

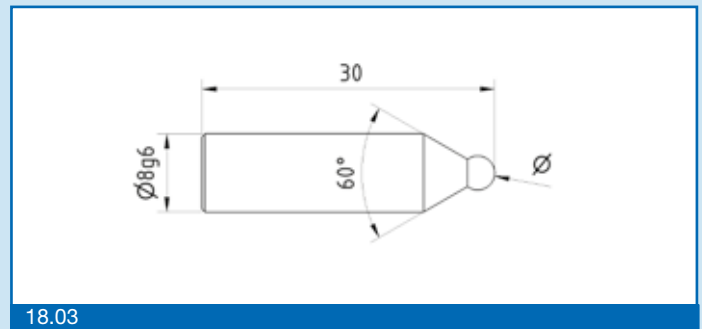

18.03

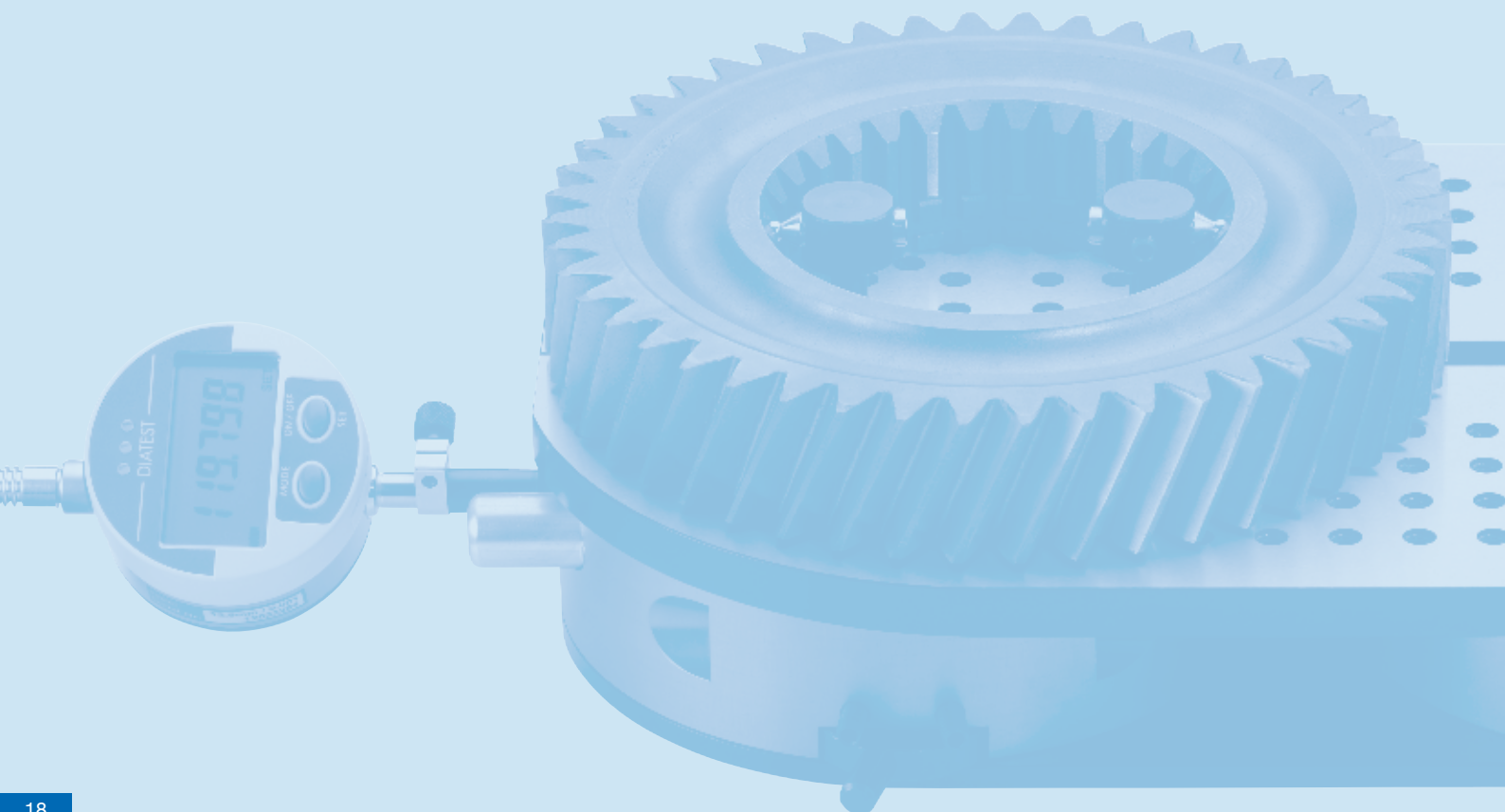

### Anschläge

Anschläge dienen dazu, ein Werkstück in der gewünschten Mess-Position zu stoppen.

### Stops

Stops are used to locate a work piece in the required measuring position.

CO-STA26 Verstellbarer Anschlaghalter, L=26 mm; Verstellbereich 11 mm; zusätzliche Anschlagstange notwendig bspw. CO-ST60-M2,5.

Abb./Picture 19.01

CO-STA26: Adjustable stop, L=26 mm; Adjustment range 11 mm; additional fixed stop bar required, e. g. CO-ST60-M2,5

CO-STA50 Verstellbarer Anschlaghalter, L=50 mm; Verstellbereich 28 mm; zusätzliche Anschlagstange notwendig bspw. CO-ST60-M2,5.

CO-STA50: Adjustable stop, L=50 mm; Adjustment range 28 mm; additional fixed stop bar required, e. g. CO-ST60-M2,5

CO-ST60-M2,5 Fixe Anschlagstange, L=60mm, M2,5; Für bspw. CO-STA26 oder CO-STA50

Abb./Picture 19.02

CO-ST60-M2,5 Fixed Stop bar; L=60 mm; M2,5; for e. g. CO-STA26 or CO-STA50

CO-ST100 Fixer Anschlag, L=100 mm, B=14 mm

Abb./Picture 19.03

CO-ST100 Fixed Stop, L=100 mm, W=14 mm

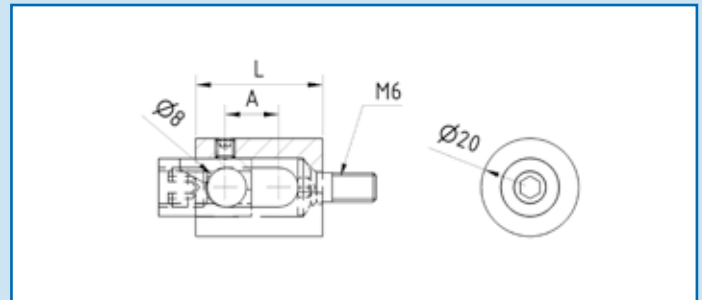

19.01

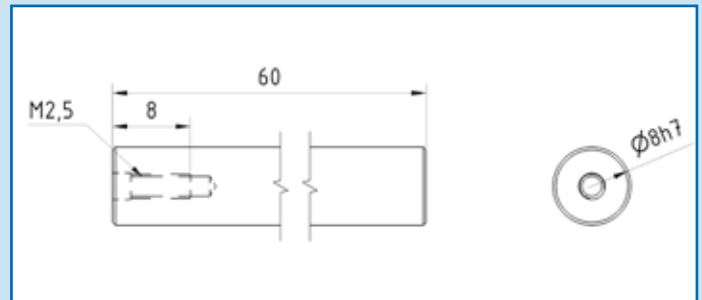

19.02

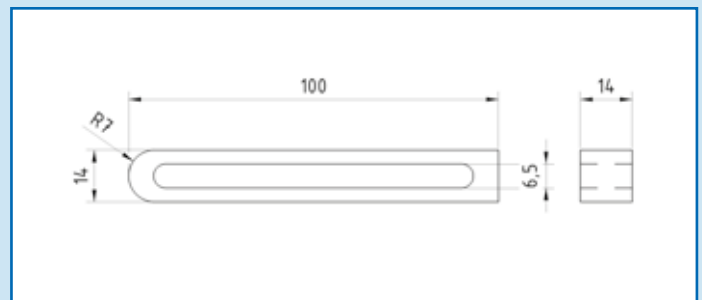

19.03

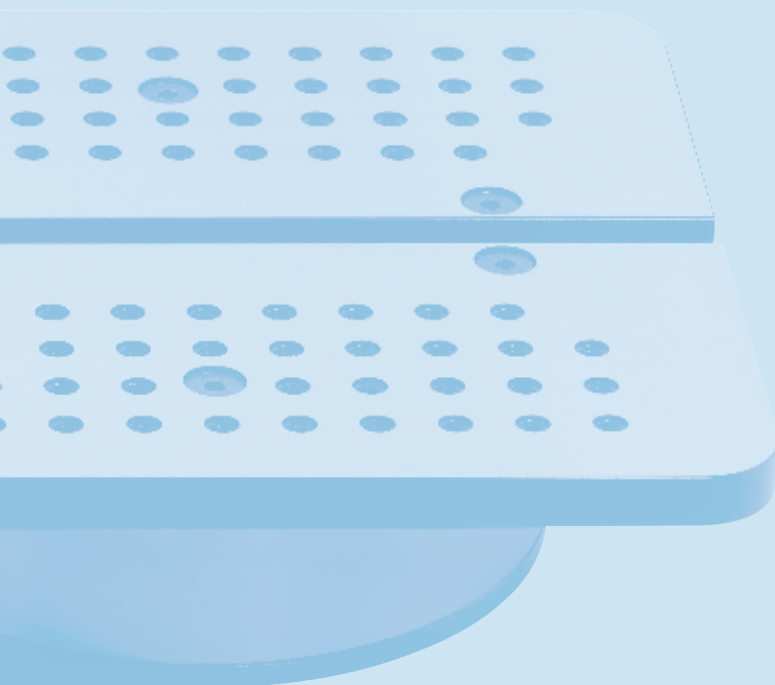



**Willrich Precision**  
**Ph 866-945-5742**  
**sales@willrich.com**

**DIATEST**  
**Hermann Költgen GmbH**

Schottener Weg 6  
D-64289 Darmstadt  
Germany

Phone +49 61519790  
Fax +49 6151979111  
E-Mail [info@diatest.com](mailto:info@diatest.com)  
[www.diatest.com](http://www.diatest.com)

**DIATEST (U.K.) Ltd.**

18, Avondale Avenue,  
Hinchley Wood, Surrey,  
KT10 0DA  
England

Phone +44 2083981100  
Fax +44 2083989887  
E-Mail: [sales@diatest.co.uk](mailto:sales@diatest.co.uk)  
[www.diatest.co.uk](http://www.diatest.co.uk)

**DIATEST –**  
**France S.A.R.L.**

Z.I. de la Malnoue, 41,  
Avenue de L'Europe  
77184 Emerainville  
France

Phone +33 160951277  
Fax +33 160174798  
E-Mail [info@diatest.fr](mailto:info@diatest.fr)  
[www.diatest.fr](http://www.diatest.fr)

**DIATEST Sverige**

AB Hans Ehlers  
Ranhammarsvägen 24  
168 67 Bromma  
Sweden

Phone +46 856470188  
Fax +46 8362279  
E-Mail [info@diatest.se](mailto:info@diatest.se)  
[www.diatest.se](http://www.diatest.se)

**DIATEST USA**

11 West College Drive  
Suite I  
Arlington Heights, IL 60004  
USA

Phone +1 8003428378  
+1 8473922060  
Fax +1 8473922197  
E-Mail [diatest@aol.com](mailto:diatest@aol.com)  
[www.diatest.us](http://www.diatest.us)

**DIATEST JAPAN Ltd.**

15-29, 1-Chome Hitotsuya  
580-0003 Matsubara City,  
Osaka  
Japan

Phone +81 723306661  
Fax +81 723338223  
E-Mail [d-info@diatest-j.co.jp](mailto:d-info@diatest-j.co.jp)  
[www.diatest-j.co.jp](http://www.diatest-j.co.jp)

**DIATEST do BRASIL**

Produtos de Medição LTDA  
R. Ulisses Cruz, n° 1.050/1052 -  
3°.andar – CJ.06 – Tatuapé  
ZIP: 03077-000 – São Paulo – SP –  
Brazil

Phone +55 1120918811  
Fax +55 1120918801  
E-Mail [info@diatest.com.br](mailto:info@diatest.com.br)  
[www.diatest.com.br](http://www.diatest.com.br)

**DIATEST MEASURING**  
**INSTRUMENTS**  
**(BEIJING) CO., LTD**

Room 1010, No. 61,  
Building Balizhuang  
Xili, Chaoyang District,  
Beijing, China

Phone +86 1065505608  
Fax +86 1085865483  
E-Mail [china@diatest.com.cn](mailto:china@diatest.com.cn)  
[www.diatest.cn](http://www.diatest.cn)

