

INTERNATIONAL
STANDARD

ISO
10664

First edition
1999-09-01

**Hexalobular internal driving feature
for bolts and screws**

Empreinte à six lobes internes pour vis



Reference number
ISO 10664:1999(E)

Foreword

ISO (the International Organization for Standardization) is a worldwide federation of national standards bodies (ISO member bodies). The work of preparing International Standards is normally carried out through ISO technical committees. Each member body interested in a subject for which a technical committee has been established has the right to be represented on that committee. International organizations, governmental and non-governmental, in liaison with ISO, also take part in the work. ISO collaborates closely with the International Electrotechnical Commission (IEC) on all matters of electrotechnical standardization.

International Standards are drafted in accordance with the rules given in the ISO/IEC Directives, Part 3.

Draft International Standards adopted by the technical committees are circulated to the member bodies for voting. Publication as an International Standard requires approval by at least 75 % of the member bodies casting a vote.

International Standard ISO 10664 was prepared by Technical Committee ISO/TC 2, *Fasteners*.

Annex A of this International Standard is for information only.

© ISO 1999

All rights reserved. Unless otherwise specified, no part of this publication may be reproduced or utilized in any form or by any means, electronic or mechanical, including photocopying and microfilm, without permission in writing from the publisher.

International Organization for Standardization
Case postale 56 • CH-1211 Genève 20 • Switzerland
Internet iso@iso.ch

Printed in Switzerland

Hexalobular internal driving feature for bolts and screws

1 Scope

This International Standard specifies the shape and basic dimensions of hexalobular internal driving feature for bolts and screws including the gauging method.

The curvature of the contour of the hexalobular internal driving feature is defined by the gauges specified in Tables 3, 4 and 5. Additional information which may be used when drawing the contour is given in the informative annex A.

The intent of this International Standard is to provide the details necessary for inspection of the hexalobular driving feature. It is not suitable for, nor intended to be used as a manufacturing standard.

2 Basic dimensions

See Figure 1 and Table 1.

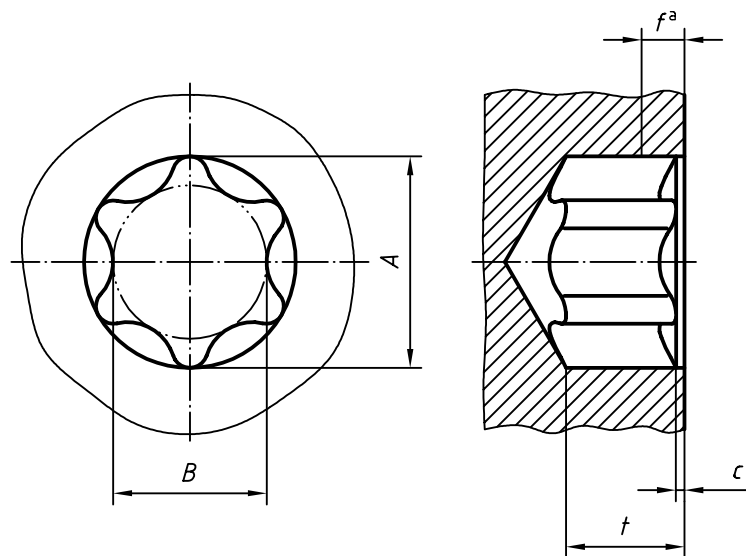

Counterbore: $c \leq 0,13$ mm up to socket No. 15, $\leq 0,25$ mm over socket No. 15

Penetration depth t : see relevant product standard

NOTE The contour of the bottom of the socket beyond the gauge is at the option of the manufacturer.

^a See Table 2.

Figure 1 — Basic dimensions

Table 1 — Basic dimensions

Dimensions in millimetres

Hexalobular socket No.	Nominal dimensions ^a	
	A	B
6	1,75	1,27
8	2,4	1,75
10	2,8	2,05
15	3,35	2,4
20	3,95	2,85
25	4,5	3,25
30	5,6	4,05
40	6,75	4,85
45	7,93	5,64
50	8,95	6,45
55	11,35	8,05
60	13,45	9,6
70	15,7	11,2
80	17,75	12,8
90	20,2	14,4
100	22,4	16

^a The curvature of the contour of the hexalobular internal driving feature is defined by the gauges specified in Tables 3, 4 and 5.

3 Gauging

3.1 Principle

The hexalobular internal driving feature shall allow the GO gauge (see 3.2) to enter freely to the penetration depth t as specified in the relevant product standards.

The NOT GO gauges (see 3.3.1 and 3.3.2) shall not enter the hexalobular internal driving feature to a depth greater than the fallaway allowance specified in Table 2.

Table 2 — Fallaway allowance

Dimensions in millimetres

Socket No.	6	8	10	15	20	25	30	40	45	50	55	60	70	80	90	100
Fallaway allowance f	0,31	0,41	0,51	0,51	0,64	0,64	0,76	0,89	1,02	1,27	1,27	1,27	1,52	1,52	1,78	2,03

All gauging is performed with reference to the top surface of the head. In the case of oval or round top heads, measurements are taken from the actual intersection of the top surface of the head and the hexalobular internal driving feature counterbore.

When using a dial penetration gauge this should be adjusted to zero while the gauge is pressed against a flat surface thereby compressing the plunger to make it flush with the gauge reference surface. See Figure 2.

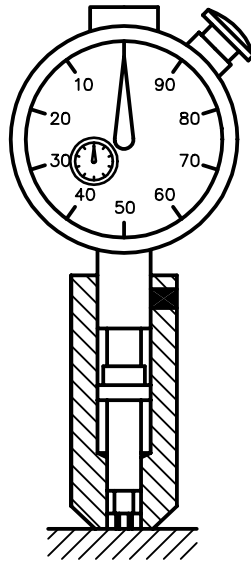
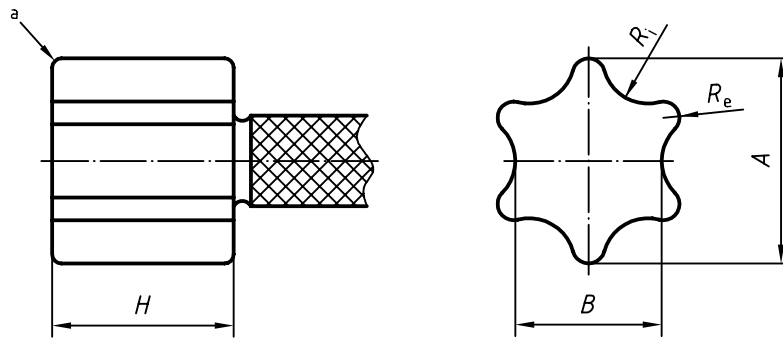

Figure 2 — Dial gauge in zero position

3.2 GO gauge

The GO gauge shall have dimensions within the limits specified in Table 3.



^a Radius max. 0,076 mm at juncture of side and face for gauge sizes \geq No. 10 and max. 0,025 4 mm for gauge sizes $<$ No. 10

Figure 3 — Dimensions of the GO gauge

Table 3 — Limiting sizes of dimensions of the GO gauge

Dimensions in millimetres

Socket No.	<i>A</i>		<i>B</i>		<i>R_i</i>		<i>R_e</i>		<i>H</i>	
	min.	max.	min.	max.	min.	max.	min.	max.	min.	max.
6	1,695	1,709	1,210	1,224	0,371	0,396	0,130	0,134	1,33	1,82
8	2,335	2,349	1,672	1,686	0,498	0,523	0,188	0,193	2,54	3,05
10	2,761	2,776	1,979	1,993	0,585	0,609	0,227	0,231	3,05	3,56
15	3,295	3,309	2,353	2,367	0,704	0,728	0,265	0,269	3,30	3,81
20	3,879	3,893	2,764	2,778	0,846	0,871	0,303	0,307	3,56	4,07
25	4,451	4,465	3,170	3,185	0,907	0,932	0,371	0,378	3,94	4,45
30	5,543	5,557	3,958	3,972	1,182	1,206	0,448	0,454	4,44	4,95
40	6,673	6,687	4,766	4,780	1,415	1,440	0,544	0,548	5,08	5,59
45	7,841	7,856	5,555	5,570	1,784	1,808	0,572	0,576	5,71	6,22
50	8,857	8,872	6,366	6,380	1,804	1,828	0,773	0,777	5,97	6,48
55	11,245	11,259	7,930	7,945	2,657	2,682	0,765	0,769	6,22	6,73
60	13,302	13,317	9,490	9,504	2,871	2,895	1,065	1,069	7,68	8,17
70	15,588	15,603	11,085	11,099	3,465	3,489	1,192	1,196	8,46	8,96
80	17,619	17,635	12,646	12,661	3,625	3,629	1,524	1,529	9,4	9,9
90	20,021	20,035	14,232	14,246	4,456	4,480	1,527	1,534	10,06	10,56
100	22,231	22,245	15,820	15,834	4,913	4,937	1,718	1,724	10,85	11,35

3.3 NOT GO gauges

3.3.1 Gauging the fallaway of dimensions A and R_e

The NOT GO gauge for dimensions A and R_e shall have dimensions within the limits specified in Table 4.

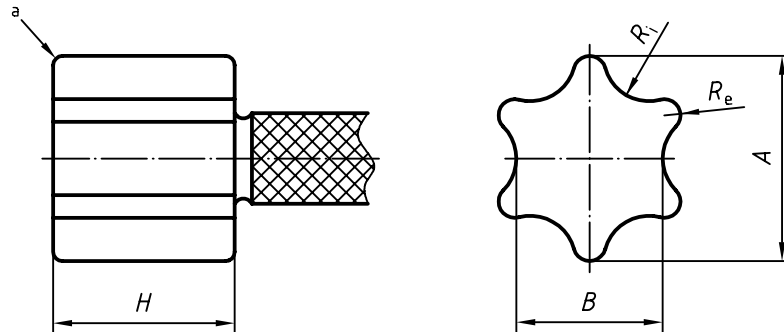

^a Radius max. 0,076 mm at juncture of side and face for gauge sizes \geq No. 10 and max. 0,025 4 mm for gauge sizes $<$ No. 10

Figure 4 — NOT GO gauge for dimensions A and R_e

Table 4 — Limiting sizes of dimensions of the NOT GO gauge for dimensions A and R_e

Dimensions in millimetres

Socket No.	A		B max.	R_i		R_e		H $\pm 0,25$
	min.	max.		min.	max.	min.	max.	
6	1,778	1,785	1,181	0,231	0,241	0,173	0,180	1,57
8	2,419	2,425	1,664	0,36	0,37	0,231	0,238	2,79
10	2,845	2,852	1,956	0,431	0,441	0,269	0,276	3,3
15	3,379	3,385	1,956	0,398	0,408	0,307	0,315	3,56
20	3,963	3,970	2,616	0,602	0,614	0,345	0,353	3,81
25	4,560	4,566	2,868	0,637	0,647	0,429	0,436	4,19
30	5,652	5,659	3,886	0,939	0,949	0,505	0,513	4,7
40	6,807	6,814	4,661	1,112	1,125	0,612	0,619	5,33
45	7,976	7,983	4,661	1,110	1,123	0,640	0,648	5,97
50	8,992	8,999	6,413	1,628	1,640	0,840	0,848	6,22
55	11,405	11,412	7,684	2,176	2,189	0,845	0,853	6,48
60	13,488	13,495	7,684	2,153	2,164	1,158	1,165	7,92
70	15,774	15,781	10,262	2,545	2,557	1,285	1,292	8,71
80	17,831	17,838	11,760	2,608	2,621	1,628	1,635	9,52
90	20,257	20,264	12,827	3,111	3,121	1,648	1,656	10,31
100	22,467	22,473	15,240	4,006	4,018	1,839	1,847	11,1

3.3.2 Gauging the fallaway of dimension B

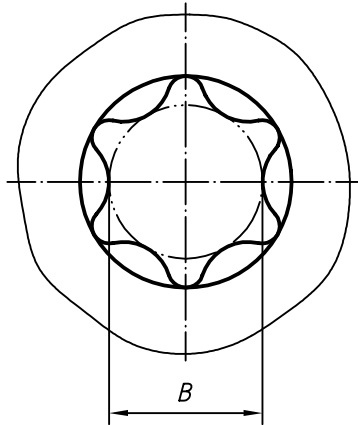

Figure 5 — Cylindrical zone to be gauged

A cylindrical NOT GO gauge with diameter as specified in Table 5 shall not enter the hexalobular internal driving feature to a depth greater than the fallaway allowance specified in Table 2.

Table 5 — Diameter of the cylindrical NOT GO gauge for dimension B

Dimensions in millimetres

Socket No.	Diameter of the cylindrical NOT GO gauge	
	min.	max.
6	1,440	1,445
8	1,920	1,925
10	2,280	2,285
15	2,760	2,765
20	3,280	3,285
25	3,720	3,725
30	4,660	4,665
40	5,600	5,605
45	6,660	6,665
50	7,380	7,385
55	9,660	9,665
60	11,340	11,345
70	13,340	13,345
80	14,920	14,925
90	17,160	17,165
100	19,020	19,025

4 Designation

EXAMPLE A hexalobular internal driving feature, socket No. 20 is designated as follows:

Hexalobular internal driving feature ISO 10664 - 20

Annex A (informative)

Representation of hexalobular internal driving feature contour

NOTE The correlations of dimensions given in Figure A.1 are intended to support the drawing of the driving feature only, e.g. when using a CAD system.

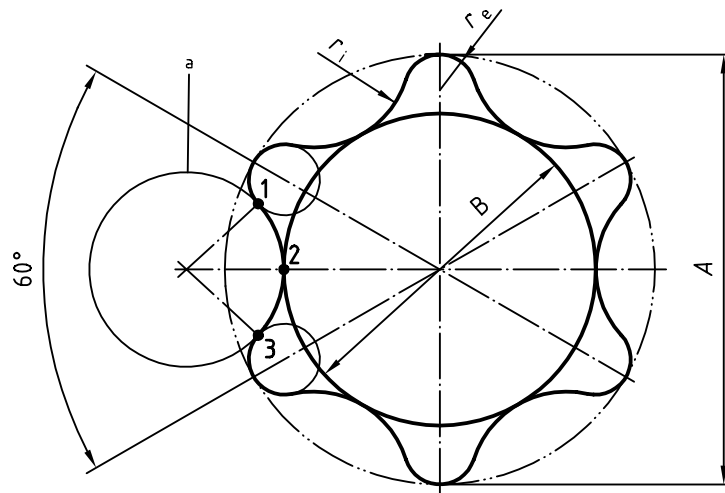

$$B \approx 0,72 A$$

$$r_e \approx 0,1 A$$

$$r_1 \approx 0,175 A$$

^a Circle is tangential to the socket contour at points 1, 2 and 3.

Figure A.1 — Representation of hexalobular internal driving feature

