

MarSurf

Mahr

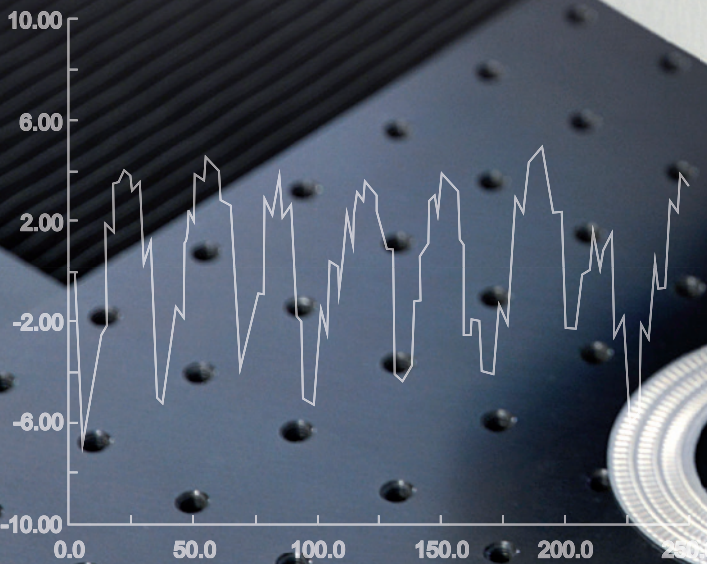

OPTICAL
3D PROFILOMETRY

OPTICAL 3D SURFACE METROLOGY FOR INDUSTRY AND RESEARCH

- Proven technology
- High flexibility and individual configuration

This is what we mean by **EXACTLY!**

- 0 +

Mahr

EXACTLY

OPTICAL 3D SURFACE METROLOGY

FOR INDUSTRY AND RESEARCH

RESEARCH AND
DEVELOPMENT



PROCESS
CONTROL



PRODUCTION
CONTROL

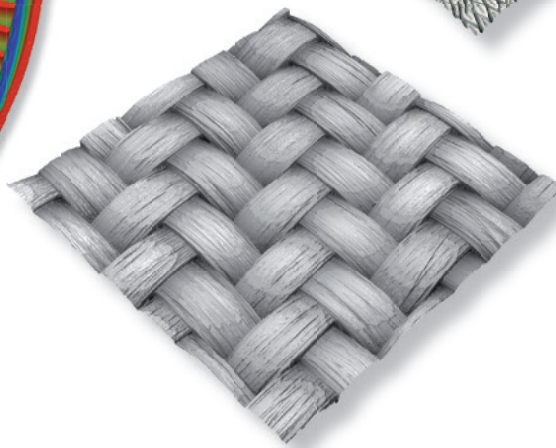
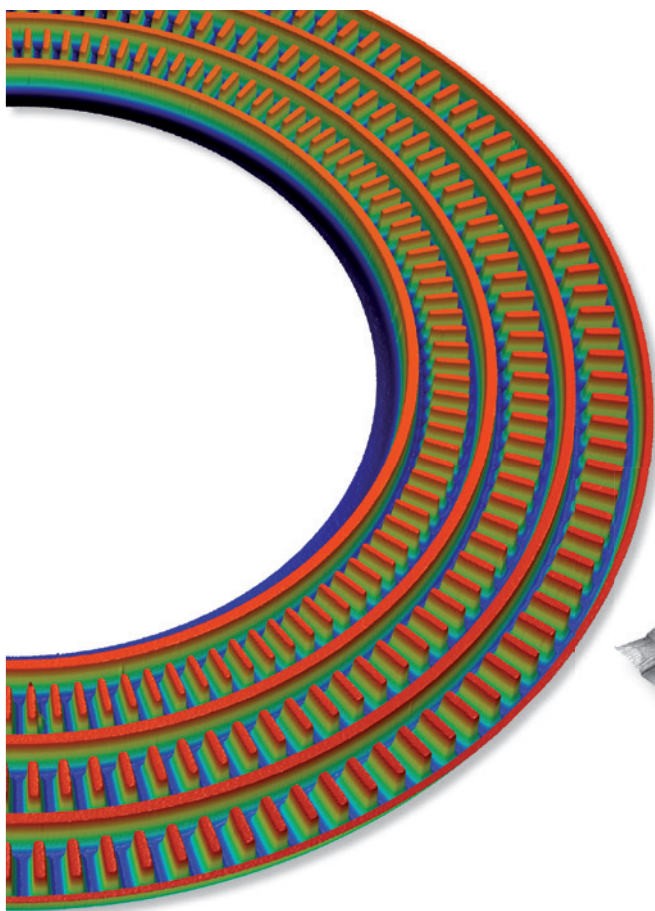

MarSurf CP & CL *select* - PLATFORM

OPTICAL 3D PROFILOMETERS FOR THE LABORATORY AND PRODUCTION

1 High flexibility

Thanks to material-independent measurement and versatile sensor combinations, MarSurf technology can be used in a large number of measurement applications.

2 Custom configuration

Depending on the measurement task, different sensors, hardware components, and software solutions can be assembled flexibly.

3 Industrial-strength automation

Typical industrial requirements for user-independent series measurements can be comprehensively satisfied.

4 Intuitive operation

The efficient operation of the measurement system is provided by a refined operating concept, thanks to ergonomic hardware and software.

5 High repeatability

Stable construction on granite guarantees the highest possible repeatability of measurements, even when used in production environments.

6 High-quality construction

Powerful, low-maintenance high-end components guarantee the highest possible measurement precision and service life of the measurement system.



MarSurf CP & CL *select*

OPTICAL 3D PROFILOMETERS FOR THE LABORATORY AND PRODUCTION

FLEXIBILITY AND EFFICIENCY

- The measurement systems can be used in the laboratory as well as in production environments.
- Measurements are possible on nearly any material.
- The intuitive user guidance of the measurement software ensures an easy, quick start to the measurement process.
- No time-consuming sample preparation is required (for example orientation, anti-reflective coating, or sputtering).
- Surface scans and 2D profiles can be completed in a few seconds.
- The high measurement speed is accelerated even more by functions like bi-directional scanning.

QUALITY AND STANDARDS COMPLIANCE

- Numerous ISO-compliant profile and surface parameters guarantee the comparability and usability of results.
- Mahr always implements the latest standards in measuring systems and software.
- Conventional 2D measured values can be supplemented at any time with current 3D measured values. These values provide new possibilities for evaluation and statistical metrics.
- The measurement systems provide new information about surface structure and machining processes.

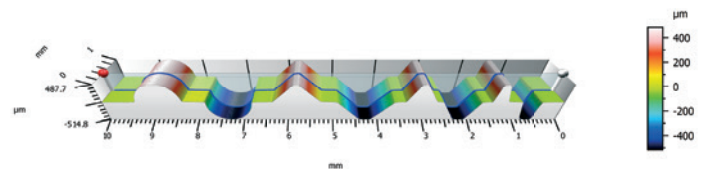
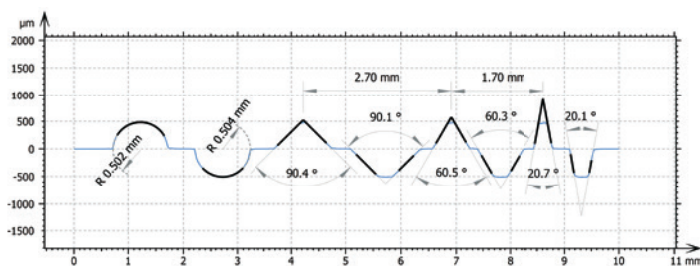
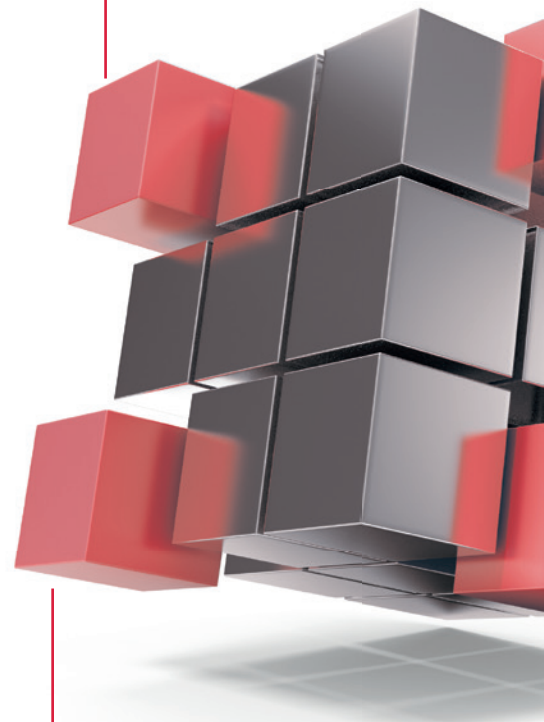



AUTOMATION

- The measurement process and data analysis can be entirely automated.
- Measurement data is placed into a complete measurement report without time-consuming intermediate steps.
- Thanks to fiducial mark detection, possible errors in sample positioning can be detected and corrected automatically.
- Integrated measurement range tracking make industrial-strength fully automated measurement possible.
- Industrial requirements for complete automation are satisfied by functions like user administration, database connections, tolerance checks, and SPC charts.

REPRODUCIBILITY

- Physical data collection leads to repeatably accurate and reproducible measurements.
- The commissioning of all systems is based on calibration with certified standards. A signed acceptance protocol including calibration certificates is provided.
- The option of automation guarantees maximum reproducibility of measurement results.
- Measurement units from Mahr have a stable mechanical construction that minimizes environmental influences.



MarSurf OPTICAL 3D PROFILOMETRY

2D APPLICATIONS

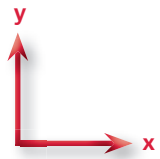

2D

Contour

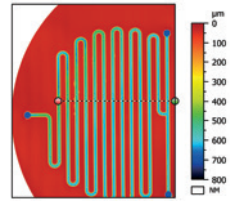
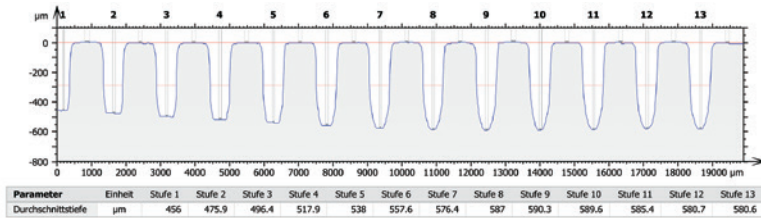

Channels in a microfluid chip

Straightness

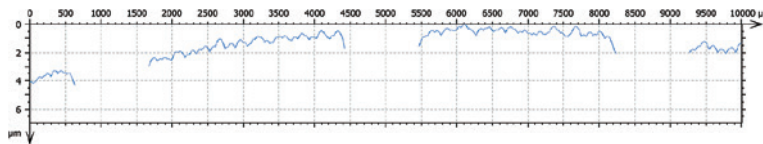

ISO 12780		
Oberflächenrauheits-Parameter		
STRt	4.3 µm	Geradheitsabweichung Spitze zu Tal
STRp	1.3 µm	Geradheitsabweichung Spitze zu Referenz
STRv	3 µm	Geradheits-Abweichung Referenz zu Tal
STRq	1 µm	Durchschnittliche quadratische Geradheitsabweichung

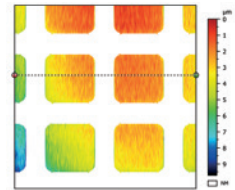

Contact pads on an electronic board

Cross-sectional area

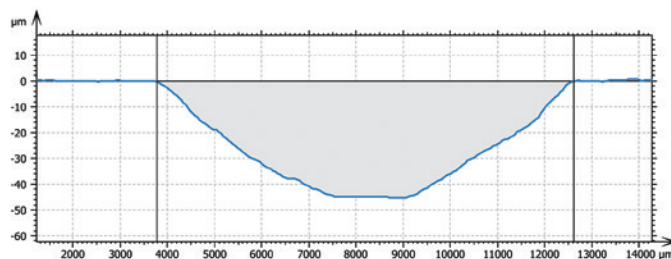

Parameter	Wert	Einheit
Maximale Tiefe	45.4	µm
Fläche der Mulde	256278.1	µm ²

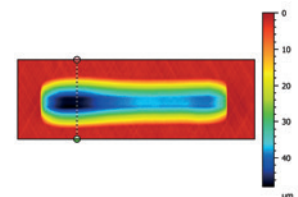

Wear marks on a metal sample

3D APPLICATIONS

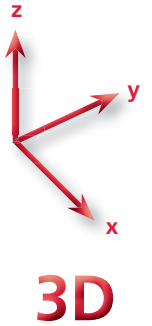

Form

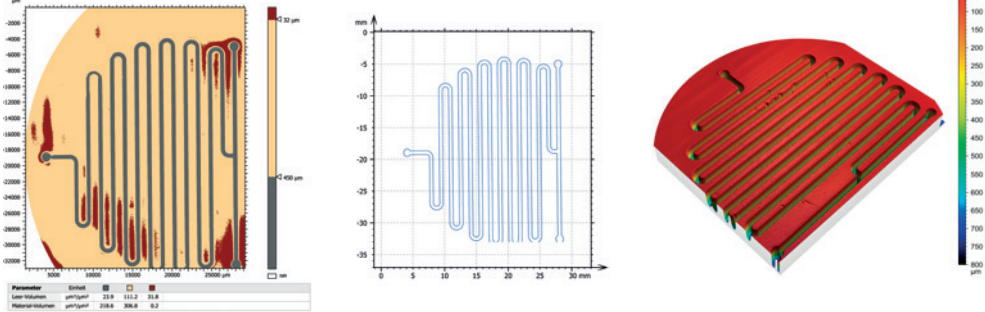

Channels in a microfluidic chip

Flatness

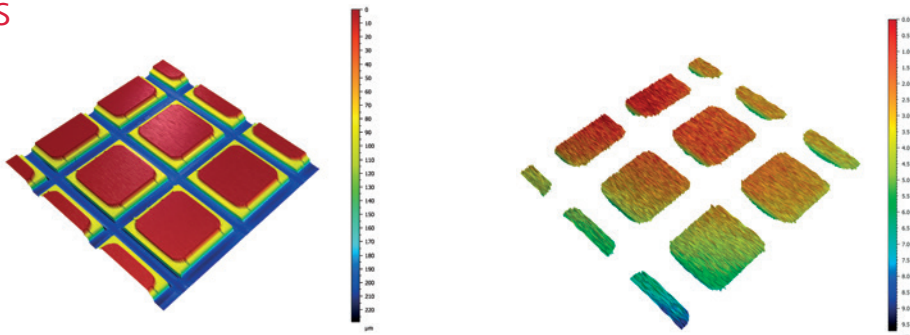

Contact pads on an electronic board

ISO 12781		
Ebenheitsparameter		
FLTt	9.7 µm	Spitze-zu-Mulde Ebenheitsabweichung der Oberfläche
FLTp	3.1 µm	Ebenheitsabweichung von der Spitze zur Referenzlinie
FLTv	6.6 µm	Ebenheitsabweichung Referenz zu Tal
FLTq	1.4 µm	Durchschnittliche quadratische (RMS) Ebenheitsabweichung

Volume/Wear

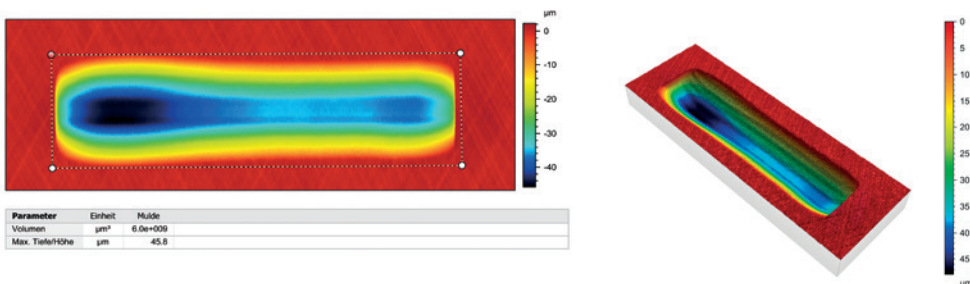

Wear marks on a metal sample

MARSURF OPTICAL 3D PROFILOMETRY

2D APPLICATIONS

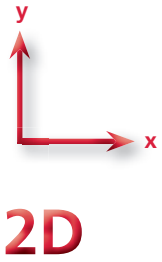

Layer thickness

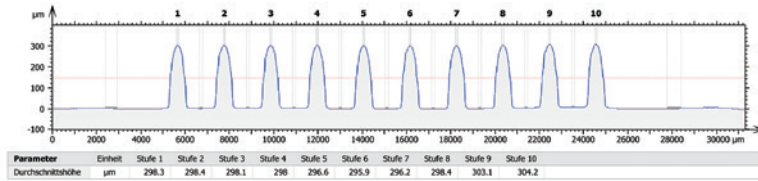

Paste on ceramic substrate

Warpage/Coplanarity

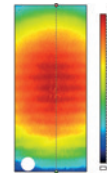
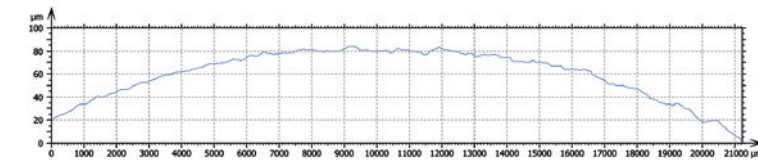

ISO 12780
Oberflächenrauheits-Parameter
STRt 83.9 µm Geradheitsabweichung Spitze zu Tal

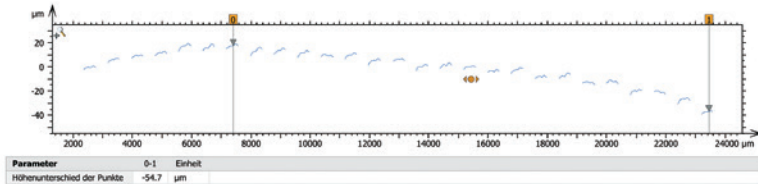

SMD component

Profile roughness

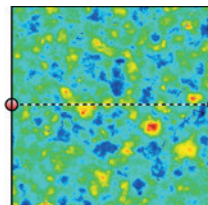
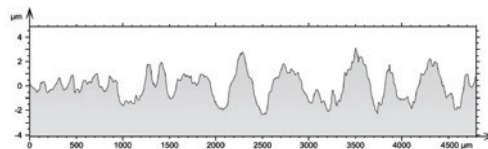

Structured sheet metal

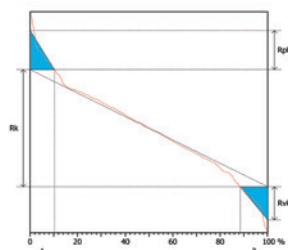

ISO 4287	
Amplituden-Parameter - Rauheitsprofil	
Ra	1.05 µm Arithmetische Durchschnittsabweichung des Rauheitsprofils.
Rq	1.21 µm Durchschnittliche quadratische Abweichung (RMS) vom Rauheitsprofil.
Rsk	0.05 Schiefe des Rauheitsprofils.
Rku	2.03 Kurtosis des Rauheitsprofils.
Rz	4.28 µm Maximale Höhe des Rauheitsprofils.
Rt	5.67 µm Gesamte Höhe des Rauheitsprofils.
ISO 13565	
ISO 13565-2	
Rk	3.51 µm Korn-Rauheitsiefe.
Rpk	0.93 µm Reduzierte Spitzentiefe.
Rvk	0.59 µm Reduzierte Muldentiefe.
Mr1	8.99 % Oberes Materialverhältnis.
Mr2	93.04 % Unteres Materialverhältnis.

3D APPLICATIONS

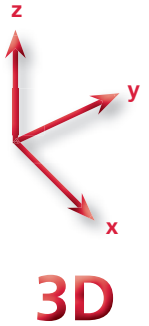

Layer thickness

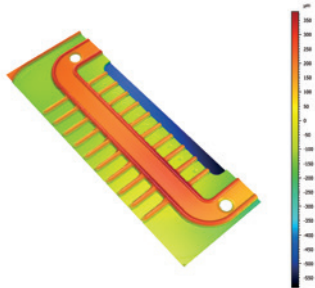

Paste on ceramic substrate

Parameter	Wert	Einheit
Durchschnittshöhe - Stufe 1 - Mittelwert	298.8	µm ✓
Durchschnittshöhe - Stufe 2 - Mittelwert	298.8	µm ✓
Durchschnittshöhe - Stufe 3 - Mittelwert	298.7	µm ✓
Durchschnittshöhe - Stufe 4 - Mittelwert	298.6	µm ✓
Durchschnittshöhe - Stufe 5 - Mittelwert	298.5	µm ✓
Durchschnittshöhe - Stufe 6 - Mittelwert	299.2	µm ✓
Durchschnittshöhe - Stufe 7 - Mittelwert	299	µm ✓
Durchschnittshöhe - Stufe 8 - Mittelwert	299.4	µm ✓
Durchschnittshöhe - Stufe 9 - Mittelwert	299.6	µm ✓
Durchschnittshöhe - Stufe 10 - Mittelwert	299.6	µm ✓

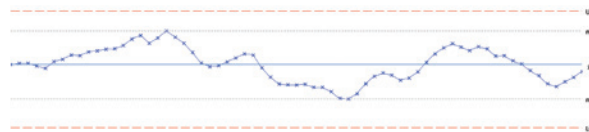

Warpage/Coplanarity

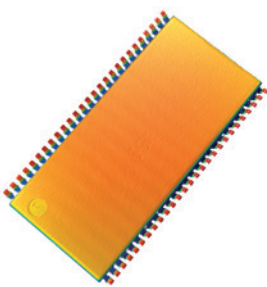

SMD component

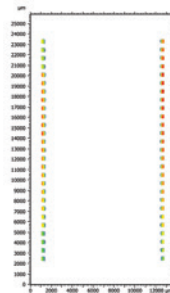
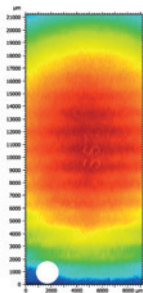
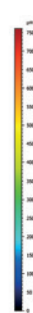

ISO 12781	
Ebenheitsparameter	
FLTi	93.4 µm Spitze-zu-Mulde Ebenheitsabweichung der Oberfläche

ISO 12781	
Ebenheitsparameter	
FLTi	117 µm

Surface roughness

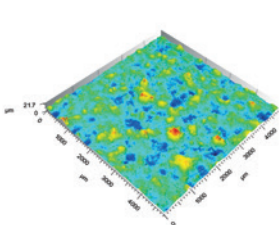

Structured sheet metal

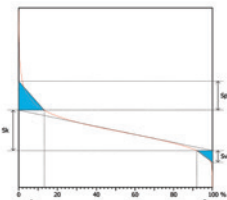
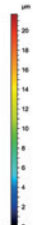

ISO 25178		
Höhen-Parameter		
Sa	1.65 µm	Arithmetische Durchschnittshöhe
Sq	2.19 µm	Durchschnittliche quadratische Höhe
Sp	14.6 µm	Maximale Spitzenhöhe der Oberfläche
Sv	7.08 µm	Maximale Muldenhöhe
Sz	21.68 µm	Maximale Höhe
Topographieparameter-Parameter		
S10z	13.42 µm	Zehn-Punkte-Höhe
Funktions-Parameter (Mehrschichtige Oberflächen)		
Sk	3.35 µm	Kern-Rauheitstiefe
Spk	2.47 µm	Reduzierte Spitzenhöhe
Svk	1.16 µm	Reduzierte Muldentiefe

MARSURF OPTICAL 3D PROFILOMETRY

3D APPLICATIONS FOR AREAL MEASUREMENT

Surface roughness according to ISO 25178, surface area ratio, isotropy

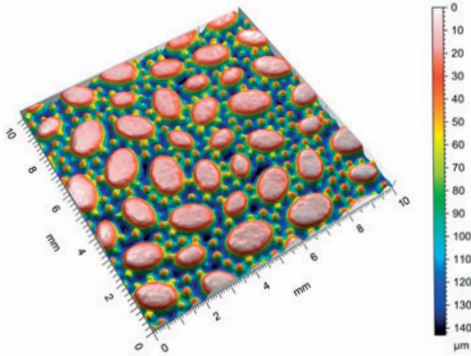

ISO 25178		
Height Parameters		
Sa	35.7 μm	Arithmetic mean height
Sp	69.8 μm	Maximum peak height
Sv	83 μm	Maximum pit height
Sz	153 μm	Maximum height
Feature Parameters		
S10z	124 μm	Ten point height
Functional Parameters (Stratified surfaces)		
Sk	36.9 μm	Core roughness depth
Spk	19.5 μm	Reduced summit height
Svk	47.3 μm	Reduced valley depth

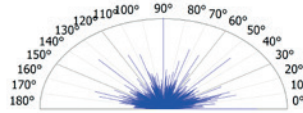

Parameters	Value	Unit
Isotropy	86	%

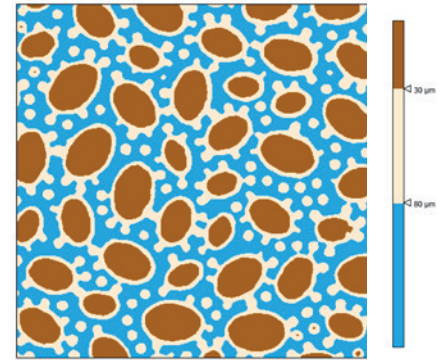

Parameters	Unit	Value
Projected area	%	36.9 30.7 32.4

Automotive industry

- Electronics
- Interior

Geometry

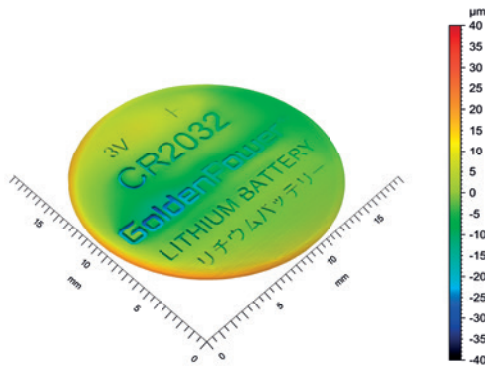

Energy

- Batteries
- Fuel cells

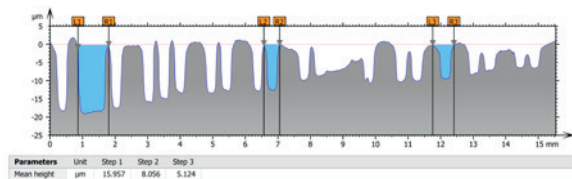

Coplanarity, flatness, layer thickness

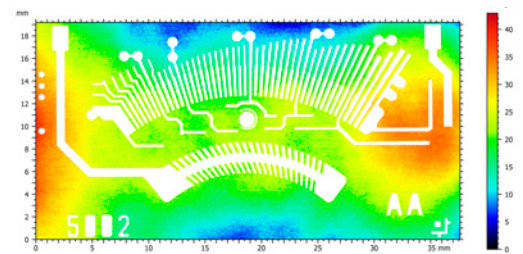
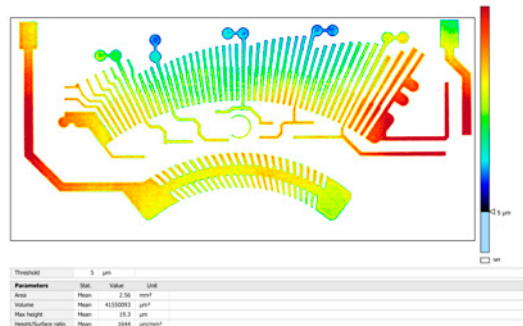
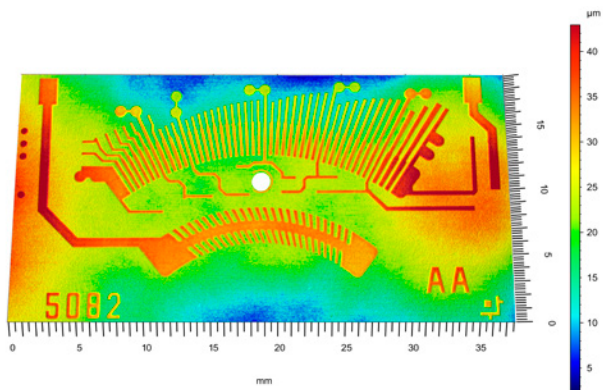

Electronics

- Chips
- Semiconductors

Volume

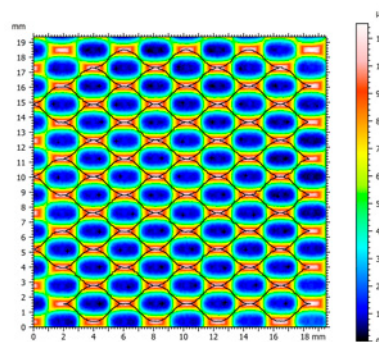
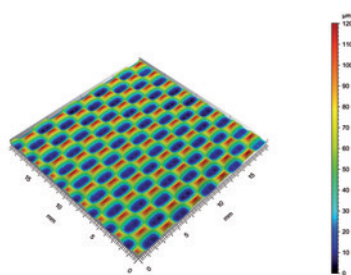

Printing industry

- Decors
- Interior

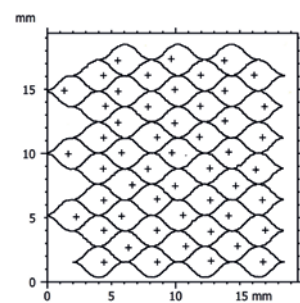

Number of motifs			
52			
Parameters	Stat.	Value	Unit
Height	Mean	0.0467	mm
	Std dev	0.00176	mm
	Min	0.0418	mm
	Max	0.0501	mm
Area	Mean	5.03	mm ²
	Std dev	0.0402	mm ²
	Min	4.96	mm ²
Volume	Mean	0.0803	mm ³
	Std dev	0.00342	mm ³
	Min	0.0694	mm ³
	Max	0.0865	mm ³

MarSurf OPTICAL 3D PROFILOMETRY INDUSTRIES

Automotive industry

- Electronics
- Interior
- Glass components
- Drivetrain

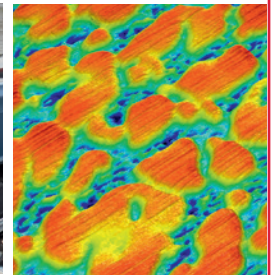

Power engineering

- Fuel cells
- Batteries
- Turbines

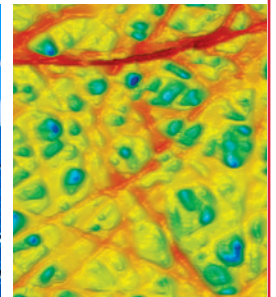

Electronics and semiconductors

- BGA
- MEMS
- High-performance electronics
- Microelectronics
- Microvias
- Hybrid technology
- Conductor tracks and circuit boards

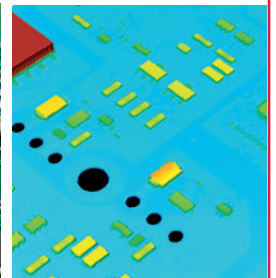

Microsystem technology

- Microoptics
- LED
- Pressure sensors
- Microfluidics

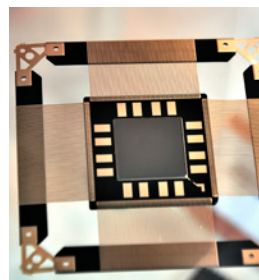

Printing and paper industry

- Printing plates
- Banknotes
- Paper screens
- Security features



Medical technology

- Microfluidics
- Sensors
- Smart materials
- Microtomes
- Implants

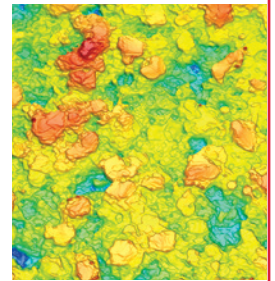

Tool systems

- Razor blades
- Microtools
- Sandpaper
- Cutting and grinding tools



Material science

- Surface machining
- New materials
- Laminates
- Fibers

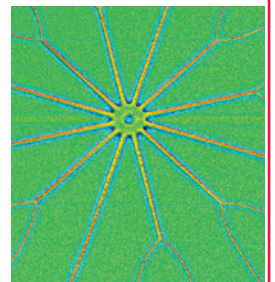
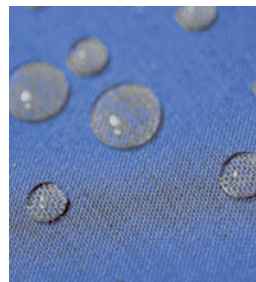

MarSurf OPTICAL 3D PROFILOMETRY

EXAMPLES OF APPLICATION

Grinding

- Tools
- Sandpaper
- Contactor armature



Measurement parameters: surface quality, flatness, grain size, grain density

Screen printing

- Circuit boards
- Electrical circuits
- Solar cells
- Rear window heaters



Measurement parameters: layer heights, layer widths, screen stretching

Injection molding

- Razor blades
- Housings
- Technical plastics



Measurement parameters: angle, width, height, contour

Laser processing

- Printing rollers
- Laser marking
- Microvias



Measurement parameters: hole diameter, trough width, raised collars, erosion volume

Stamping

- Coins
- Laminate edging
- Artificial leather
- Chip cards
- Plastic channels
- Rollers

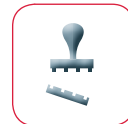

Measurement parameters: structural depths, roughness, channel width and height

Tribology

- Bearings
- Guides
- Gears
- Motors
- Contacts

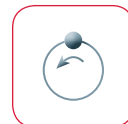

Measurement parameters: wear volume, depth, contact burning

Fine machining

- Diesel injectors
- Contact surfaces
- Membranes
- Precision components



Measurement parameters: flatness, waviness

MarSurf OPTICAL 3D PROFILOMETRY TECHNOLOGY

Different sensors available for fast, contact-free and nondestructive measurement.

Chromatic sensor CLA

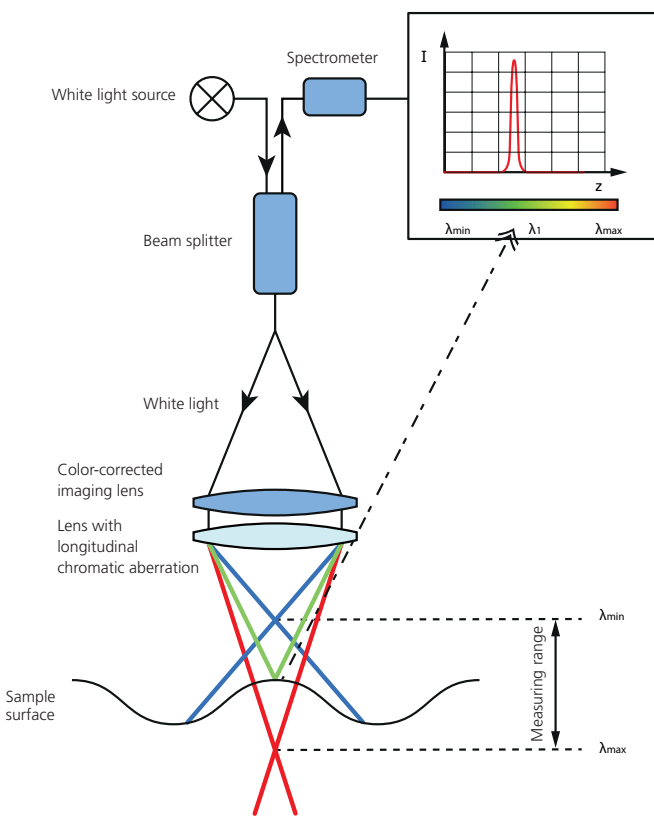

Chromatic sensor CLA

- Sensors with vertical measurement ranges from 0.1 mm to 10 mm depending on application
- High vertical resolution with optimized signal/noise ratio
- Measurement rates up to 4 kHz
- Dynamic brightness adjustment
- Long-lasting, powerful LED light source
- Precise measurements in hard-to-reach places thanks to compact construction
- Suitable for roughness measurement
- Layer thickness measurement and measurement of transparent materials possible

The CLA chromatic sensor works on the confocal principle. During recording of measurement values the dispersive property of light is used. A lens with a pronounced chromatic length aberration focuses the blue portion of the light closer to the lens and the red farther away. A spectrometer detects the resulting color differences, from which the height of the sample surface can be calculated. This permits the surface to be imaged at different distances without the need for a sampling movement along the optical axis.

Layer thickness measurement with chromatic sensors

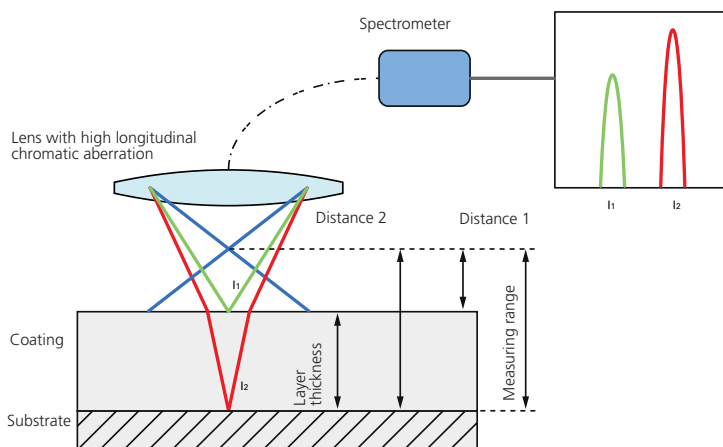

In transparent layers, the light is reflected at the air-coating interface and on the coating-substrate interface. Both layers can be detected by the sensor, allowing the layer thickness to be determined.

Chromatic sensor CLS



Chromatic sensor CLS

- Sensors with vertical measurement range up to 4 mm
- Line width up to 4.8 mm
- 384,000 points/s

The chromatic line sensor CLS focuses 192 points along a line of light onto the surface of the workpiece. For each of the 192 channels, the reflected light is spectrally analyzed to determine the height.

POWERFUL SOFTWARE SOLUTIONS



INTUITIVE MEASUREMENT

- Refined user guidance
- Prescan function (Navigator)
- Just a few clicks to the measurement (snapshot technology)
- Automatic brightness adjustment (auto-intensity) when using CLA sensors
- Storage of all parameters as template for similar measurements (template function)

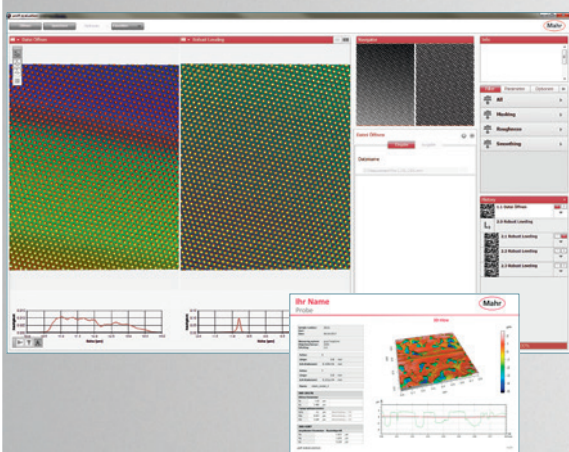

EFFECTIVE ANALYSIS AND DOCUMENTATION

- User-independent
- Powerful automation
- Customer-specific adaptation and reporting
- 3D analysis, ISO 25178, ISO 13565, ISO 12781, etc.
- 2D analysis, ISO 4287
- Geometry, volume, contour, CAD comparison, etc.

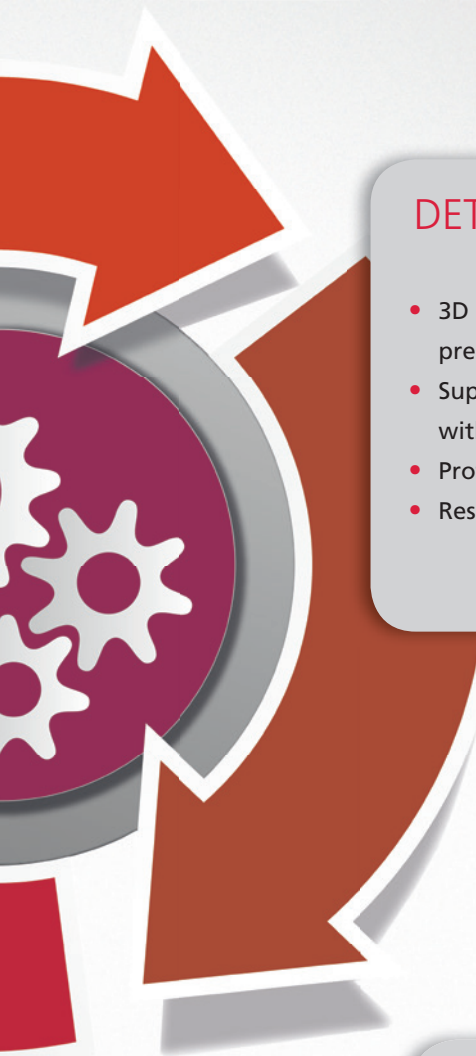

DETAILED RESULT DISPLAY

- 3D displays, fast and high-quality presentation
- Superimposition of 3D measurement data with intensity and color measurement
- Profile display
- Results display

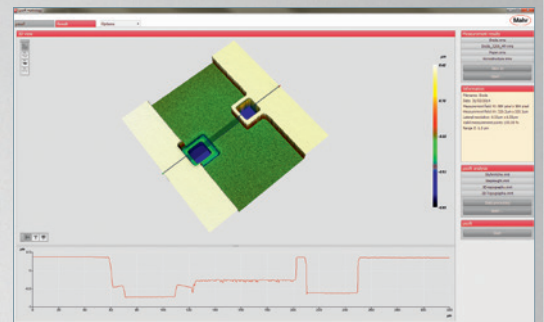

CUSTOMIZED AUTOMATION

- User-independent series measurements
- Time-efficient operation
- Different measurement tasks and reports in a single measurement recipe
- Protocol generation and SPC control
- Database-supported



POWERFUL SOFTWARE SOLUTIONS

MarSurf Metrology Software



Navigator function

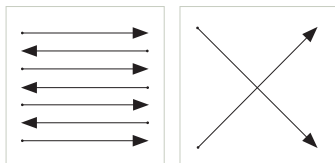

Bi-directional scanning

free profile scanning

The intuitive measurement and control software MarSurf Metrology SW guarantees the efficient performance of measurements. With the software, all sensors and an overview camera can be conveniently controlled from a single user interface. When switching between the sensors or the overview camera, the measurement head automatically moves to the defined measurement position. Powerful 3D displays of measurement results with intensity overlays are available after just a few seconds. The software is available in numerous languages.

Navigator function

With the navigator function, a rapid overview can be created in which the desired measurement range can easily be selected with the mouse.

Template function

With the template function, measurement parameters can be stored as a template. Semi-automated measurement series can be implemented easily with this feature.

Bi-directional scanning and free profile scanning

Measurement times are significantly reduced by bi-directional scanning. The start and end point of a measuring section can be flexibly set using free profile scanning.

MarSurf MfM Software

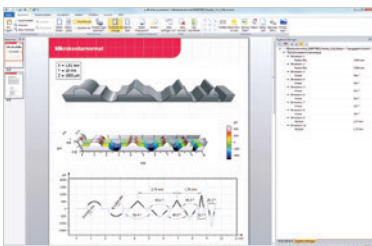

The analysis surface MarSurf Mountains for Mahr (MfM) provides an extensive function package for the display and analysis of structure, roughness, waviness, step height, contour, and other surface features.

The intuitive, multilingual user interface allows complex analytical reports to be created with the press of a button. Numerous display options such as profile view, 3D reconstruction and reflected image generate meaningful measuring reports. Custom reporting recipes are easy for users to create and implement.

The software always contains the latest standard parameters and filter functions.

The software is available in the Standard, Extended and Professional versions. Further special modules, for example statistical evaluation, are available.

MarSurf Automation Software

With MarSurf Automation SW it's easy to automate custom measurements and special analyses.

Customizable measurement recipes

An unlimited number of measurement recipes can be defined and stored in a database. The defined measurement parameters are stored in the measurement template and are available for later use.

An unlimited number of measurement positions can be defined on each individual sample. Custom sensor settings can be specified for each of these measurement positions. For series measurements, several samples are moved to and measured just as with single measurements. In this case, all the samples can be measured identically in accordance with the defined measurement settings, or the settings can be individually activated or deactivated for each sample.

Database-supported

MarSurf Automation SW has a powerful reporting library. Measurement results and reports are permanently stored and are therefore available for statistical process control. The central, network-capable database and the recipes stored there can be accessed from multiple systems.

Industrial strength

With support for registration mark detection and transmission of measured data to statistical software (such as QS-Stat), the software meets current industrial standards. Simultaneous data collection and reporting on two different computers is supported. A strict separation between operator and administrator modes guarantees the greatest possible ease of use and reliable results.

Multisensor

Measurement recipes can also be carried out by multiple sensors. Here, a defined automatic change between sensors can be defined.

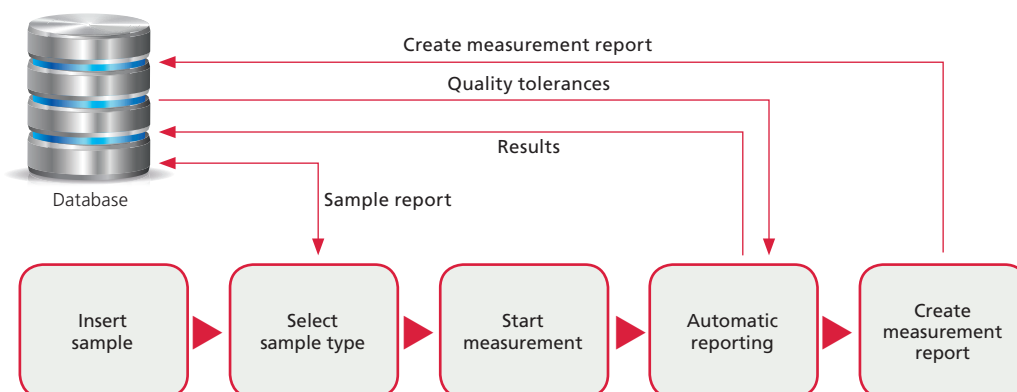

AUTOMATION WITH MarSurf AUTOMATION SOFTWARE

1 RIGHTS MANAGEMENT

- Hierarchical user administration with password protection
- Security of calibration data
- Granting of rights for operator, process, and administration levels

2 COLLECTING SAMPLE INFORMATION

- Entry of order-related information: e.g. the user ID, component type, lot number, date/time and more
- Manual input of information
- Digital entry using a barcode reader or data matrix code reader
- Automatic linking of measurement recipes to associated evaluation recipes

3 CHECKING SAMPLE POSITION

- Detection and checking of the sample position. Correction optionally possible using registration mark detection.
- Comparison of placement accuracy when inserting the sample
- Compensation for component/dimensional tolerances and corresponding corrections to measurement positions
- Acceptance of the new position and adaptation of the measurement recipe if necessary

4 MEASUREMENT

- Start of individual measurements or series measurements

5 AUTOMATIC EVALUATION

- Transmission of measurement data to the analysis software
- Analysis based on predefined report recipes or user-defined templates

6 AUTOMATIC MEASUREMENT REPORT GENERATION

- Comprehensive presentation of measurement results using transparent measurement reports
- Custom-adaptable measurement reports with highly powerful presentation
- Output possible as MS-Excel or PDF

7 EXPORT TO DATABASE

- Transmission of the measurement dataset and measurement report to a predefined database
- Export of measurement results as ASCII, in QS-Stat format, or using an Excel VBA-script

User

Password

In industry, the worldwide trend is towards user-independent automation of quality assurance. With measurement systems and automation software from Mahr, user-independent series measurements and inline inspections can be carried out efficiently. That increases throughput and reduces downtime. Measuring equipment capability is guaranteed by the high repeatability of measurements.

Lot number

Date

Time

or



Measurement recipe

Evaluation recipe

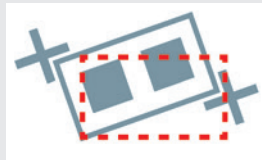

or



Evaluation

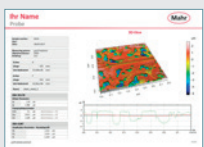

OK/NOK
SPC



MarSurf CP *select*

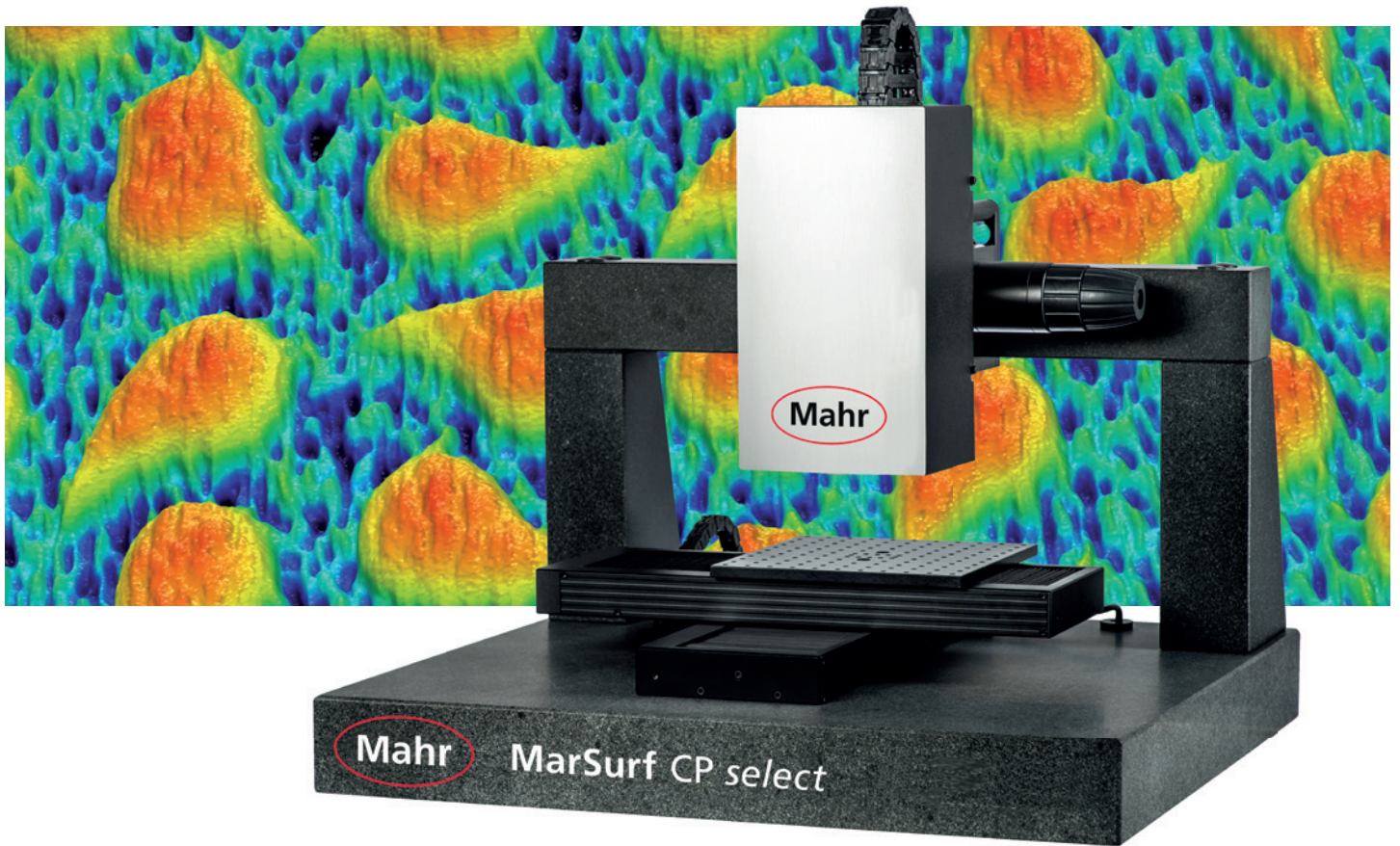

Flexible 3D profilometer for quality control

Using MarSurf CP *select* technology, you can measure up to 100 times faster than with conventional probe systems. That saves time and reduces costs.

Construction on granite and the use of first-class components guarantee high repeatability of measurements. The measurement of large and heavy samples is no problem.

MarSurf CP *select* and MarSurf CL *select* can be fully automated and conveniently integrated into quality assurance processes using industrial-strength interfaces.

The MarSurf CP *select* 3D profilometer has proven itself many times over in measuring topography, line roughness, height profile or coating thickness as part of the production process. Its modular design and capacity for connecting to different sensors allows it to be adapted to many different measuring tasks. The manual z adjustment with fine tuning guarantees high operating comfort. Alternatively, a motorized z axis is also available.

Maximum flexibility thanks to multicompatible sensor holding

The sensor holder within the measurement head is designed for the flexible support of a variety of sensors. Sensors can be inserted into the holder easily and quickly. That makes replacement or interchanging sensors as easy as it sounds. It offers numerous combination options for using the most suitable sensor technology.



MarSurf CP *select*

- High measurement speed
- Large height measurement range
- Contact-free, nondestructive
- Color overview camera
- Motorized z-axis
- Measurement range extension with z-stitching
- Can be automated
- Highly developed technology Made in Germany

MarSurf CL *select*

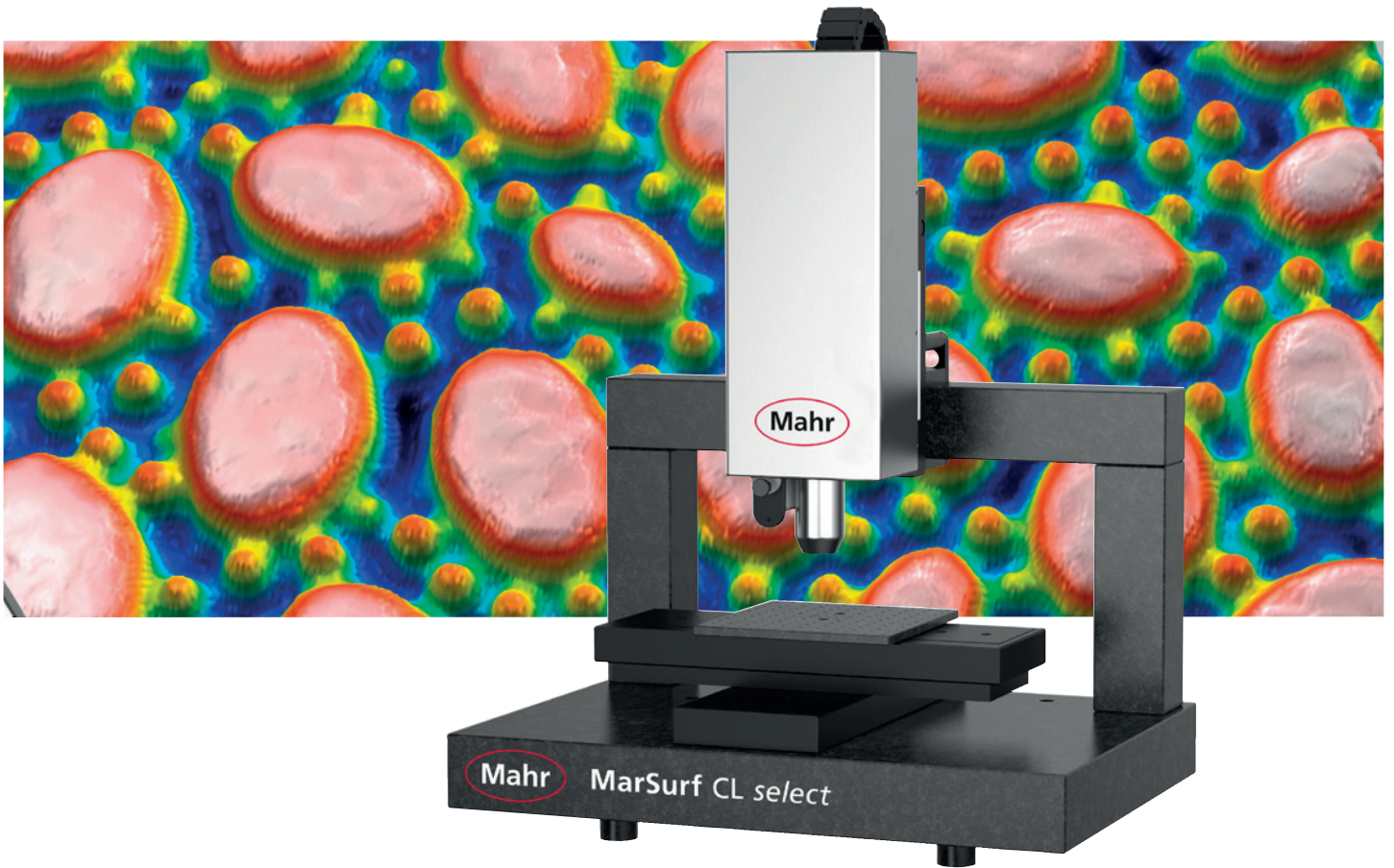

Multiple sensors in combination with MarSurf CL *select* technology

The MarSurf CL *select* is characterized by an extremely fast three-dimensional detection of large measuring surfaces with simultaneously high measuring precision. The system does not record just one profile, but 192 parallel profile lines. This allows topographies to be recorded within a few seconds from the μm to the cm range. Due to the fast measuring speed, high throughput rates can be achieved. This significantly saves you time compared to the classic profilometer.

Profile data on almost all surfaces with varying reflection properties and inclinations are recorded with high precision thanks to high dynamics. The construction on granite and the use of premium components guarantee a high repeatability accuracy of the measurements. The measurement of large and heavy workpieces is easily possible. The MarSurf CL *select* is fully automated and can be conveniently integrated into quality assurance processes via industrial interfaces.

The 3D profilometer MarSurf CL *select* has proven itself many times over in measuring topography, height profile or coating thickness as part of the production process. Its modular design and capacity for connecting to different sensors allows it to be adapted to many different measuring tasks. The motorized Z-axis guarantees high operating comfort.

➔ MarSurf CL *select*

- Large surface 3D measurements
- Very high measurement speed
- Excellent dynamics and precision
- Coating thickness measurement and measurement of transparent materials
- Contact-free and nondestructive measurement
- Can be automated
- Robust and reliable
- Highly developed technology made in Germany

MarSurf OPTICAL 3D PROFILOMETRY

TECHNICAL SPECIFICATIONS

Sensors

Point sensors	Type	Name	Measurement range (mm)	Working distance (mm)	Diameter of measurement spot (μm)	Lateral resolution (μm)	Vertical resolution (μm)	Vertical resolution ¹ (μm)	Measurement angle ² ($^\circ$)	Thickness measurement range ³ (mm)	Measurement rate (kHz)	Light source
	Chromatic sensors (CLA) ^{4,5}	CLA 0.6	0.6	6.5	4	2	0.020	0.006	90 \pm 30	0.9	4	LED
CLA 1		1	19.1	3.5	1.8	0.035	0.010	90 \pm 45	1.5			
CLA 3		3	22.5	12	6	0.100	0.030	90 \pm 30	4.5			
CLA 6		6	35	16	8	0.200	0.060	90 \pm 25	9			
CLA 10		10	70	24	12	0.300	0.100	90 \pm 20	15			

1) reduced measurement range

2) larger measurement angle possible for scattering surfaces

3) refraction index = 1.5

4) other controllers upon request

5) two sensors can be held in one holder

Sensors

Line sensors	Type	Name	Measurement range (mm)	Line length (mm)	Working distance (mm)	Diameter of measurement spot (μm)	Lateral resolution (μm)	Vertical resolution (μm)	Measurement angle ¹ ($^\circ$)	Thickness measurement range ² (mm)	Measurement rate (kHz)	Light source
	Chromatic sensors CLS ³	CLS 0.2	0.2	0.96 \pm 0.01	5.3 \pm 0.2	2	1	0.020	90 \pm 44	0.28	2	LED
CLS 1		0.95	1.91 \pm 0.01	18.5 \pm 0.2	4	2	0.080	90 \pm 33	1.35			
CLS 4		3.9	4.78 \pm 0.02	41 \pm 0.2	10	5	0.320	90 \pm 20	5.5			

1) larger measurement angle possible for scattering surfaces

2) refraction index = 1.5

3) other sensors upon request

Camera

Overview camera	Color off-axis camera	
	Field of view (mm)	up to 10 x 10
	External brightfield / darkfield illumination	optional

¹ Only for MarSurf CL select

Vertical adjustment

Adjustment unit z	Manual ¹	Adjustment distance (mm)	150
		Fine drive	optional
	Motorized	Adjustment distance (mm)	100
		Resolution z	0.1

¹ Only for MarSurf CP select

Scanning modules¹

Portal		S	M	L	XL	XXL+
Axis system x/y	Measurement range (mm)	100x150	200x200	200x300	200x300	300x300
	Resolution x/y (µm)	0.5	0.5	0.5	0.5	0.05
System controller	Standing container	Standard	Standard	Standard	–	–
	Rolling container	Optional	Optional	Optional	Standard	Standard
Base frame with passive/active vibration damping		–	–	–	Standard/ Optional	Standard/ Optional
MarSurf CP	Weight (kg)	100	130	150	250	350
	Max. sample height (mm)	125	125	125	125	125
	Max. passage width in x direction (mm)	360	500	500	720	710
	Max. sample weight (kg)	10	10	10	10	50
MarSurf CL	Max. sample height (mm)	95	95	95	95	95
	Max. passage width in x direction (mm)	360	500	500	720	710
	Max. sample weight (kg)	10	10	10	10	50

General information

Power supply	Voltage: 100-240 V; frequency: 50-60 Hz, power consumption: ca. 550 W
Computer type	Industrial PC

Software packages

MarSurf Metrology SW	Included
MarSurf Automation SW	Optional
MarSurf Mountains for Mahr SW	Optional
Export formats	X3P, NMS, OMS, FITS, ASCII, SDF, TIF, BMP, SUR

MarSurf CP select

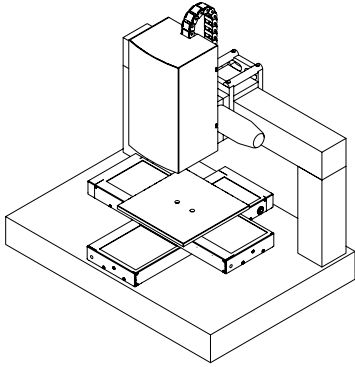

Accessories

1 Sensor module



CLA sensor

2 Add-on cameras



Overview camera

3 z-axis



Manual course drive with optional fine drive

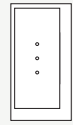

Motorized

Roughness standard

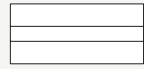

Depth setting standard



Step standard

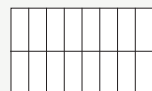

Flatness standard

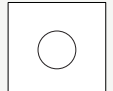

4 Portals and x/y-axes

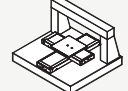
S	M	L
		
540×435×440	680×480×440	680×605×440

4 Portals and x/y-axes

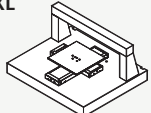
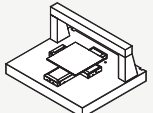
XL	XXL
	
900×750×430	900×750×560

5 Standing/rolling containers

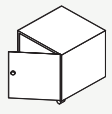
	
800×555×750	600×550×660

5 Vibration damping

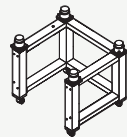

Passive or active

6 Rolling container



600×550×660

Dimensions in mm, (LxWxH)

MarSurf CL select

Accessories

Laboratory table

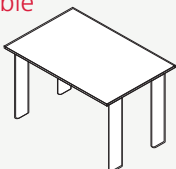

WT 100	Dimensions WxHxD (mm ³)	1000 x 750 x 800
	Weight (kg)	40
	Max. load (kg)	200
WT 150	Dimensions WxHxD (mm ³)	1500 x 750 x 1000
	Weight (kg)	70
	Max. load (kg)	200

1 Sensor module



CLS sensor

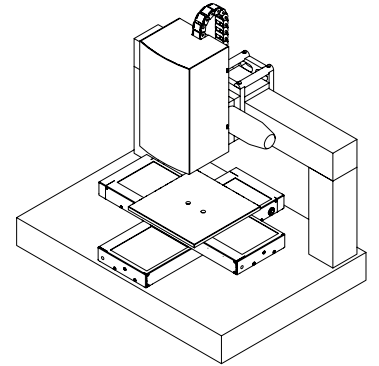

2 Add-on cameras

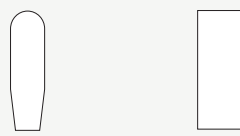

Overview camera Illumination

3 z-axis

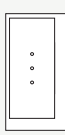

Motorized

4 Portals and x/y-axes

S	M	L
		
540x435x440	680x480x440	680x605x440

4 Portals and x/y-axes

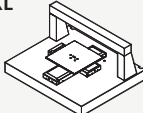
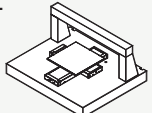
XL	XXL
	
900x750x430	900x750x560

5 Standing/rolling containers

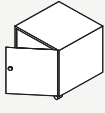
	
800x555x750	600x550x660

5 Vibration damping

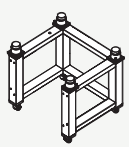

Passive or active

6 Rolling container

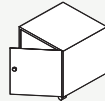

600x550x660

MarSurf OPTICAL 3D PROFILOMETRY

MarSurf METROLOGY SOFTWARE

General information	
Languages	English, German, French, Italian, Spanish, Portuguese, Polish, Japanese, Chinese, Korean, Russian, Turkish, Arabic, others to come
Ergonomics	The user interface has a clear structure and it is easy to start a measurement in just a few steps.
Navigator	With the Navigator-function, a rapid overview of the sample surface can be created in which the desired measurement range can easily be selected with the mouse.
3D preview	Fast assessment of topography recorded using a powerful 3D view. Profile cross sections can be used for a quick initial analysis.

Measurement	
Bidirectional measurement	Recording of topography by scanning in a back-and-forth movement. This accelerates measurement speeds by a factor up to 2.
Template function	Storage of the measurement currently carried out as a template in order to access the measurement settings again quickly for similar measurements.
Diagonal profiles	The recording of non-orthogonal profiles is possible.
Multisensor	Switching between the different integrated sensors is no problem. The positioning system moves back to the same sample position after switching, of course.
Remaining time display	Even before the measurement starts, you can approximate measurement time.
Height stitching (optional)	Extension of the measurement range in the z-direction by stitching together multiple scans which have been taken at different height positions. Only in combination with a motorized z-axis.

MarSurf AUTOMATION SOFTWARE

General information	
Languages	English, German, other languages upon request
Operation	Program supports the separation of measurement and analysis units (program is network-capable)
User levels	Multiple security levels with different permissions: administrator, process level, operator
Creating measurement recipe	Intuitive input form for measurement position (joystick support) and sensor settings
Data storage	Storage of measurement data/analysis results in an SQL database

Measurement	
Measurement settings	Sensor settings variable within a measurement run
Measurement recipe	Automatic approach and measurement at different positions
Series measurement	Comparison of position using reference points
Exporting results	ASCII export for integration into QS database, transmission to MarSurf Analysis SW, Excel (csv)
Number of measurements per job	unlimited

Analysis	
Results display	Custom-designed analysis protocol, SPC diagram
Reporting recipe	Each measurement point can be assigned specific measurement parameters
SPC	Input of warning and specification limits for measurement data evaluation

Evaluation	
Connections	MarSurf Mountains for Mahr SW and other analysis software

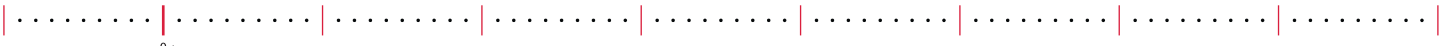

MarSurf OPTICAL 3D PROFILOMETRY

MarSurf MOUNTAINS FOR MAHR SOFTWARE

General information	
Languages	English, German, French, Italian, Spanish, Portuguese, Polish, Japanese, Chinese, Korean
Report generation	Automatic report generation, additional information (logos, identification, notes, figures)
Traceability and productivity	Analysis workflow diagram, add, change, or delete analysis steps, minidocs (analysis sequences), any document can be used as a template for the reporting of multiple measurement datasets, OK/NOK criteria can be set for each parameter, results can be exported to .csv format for Excel
Statistics	Multiple populations, control overviews, parameter tables, scatter charts, histograms

Processing	
Intelligent preprocessing	Alignment, form filtering, histogram function, resampling, filling out of unmeasured points, retouching, noise suppression, partition alignment, right-angled, round, or polygonal zoom
Metrological and scientific filters	Gaussian, robust Gaussian and spline filters, FFT, morphological filters, Laplace and Sobel filters, etc.
Segmentation	Segmentation by zoom, threshold calculation and application of binary masks
Statistics	Multiple populations, control overviews, parameter tables, scatter charts, histograms

Evaluation	
International standards	ISO 25178 3D parameters, EUR 15178 EN 3D parameter, definitions for 2D parameters in ISO 4287, ISO 13565 and other standards, ISO 16610 extended filters, ISO 12781 flatness parameters
Functional 3D analysis	Bearing ration curve, graphical study of functional volume parameters in ISO 25178, material and cavity volumes, motif analysis, surface subtraction (wear)
Particle/grain analysis	Grain/particle detection, customized grain characteristics, grain topography, statistics about grains and islands, distribution of peaks, number of peaks
Surface geometry	Distances, angles, areas, volumes, step heights on profiles and surfaces, contour
Contour analysis	Geometric dimensioning of vertical (z axis) and horizontal (x,y plane) profiles, analysis of form deviations with automatic generation of a results table
Extended analysis	Fourier spectrum, power spectrum density (PSD), structural isotropy, direction, and periodicity, fractal analysis (box counting method or morphological embedding method)

Presentation	
Analysis of different measurement data types	2D profiles, 3D surfaces, 3D surface with intensity, 3D surface with RGB image, 4D series of 3D surfaces
3D surface display	3D views in real time, images in pseudocolors, photo simulations, contour diagrams, 4D films created from 3D surfaces, simulated flights over surfaces

MarSurf CM *select*

FURTHER MarSurf TECHNOLOGIES



Mutiple sensors in combination with MarSurf CM *select* technology

The areal measurement of MarSurf CM *select* technology from Mahr can be combined with the linear measurement of MarSurf point sensors. As a multisensor system, MarSurf CM *select* is the first choice for process-related multiple sensor systems.

The integration of both industrial-strength Mahr technologies into one 3D surface measurement system offers you the option of selecting the right sensor for any given measurement ask.

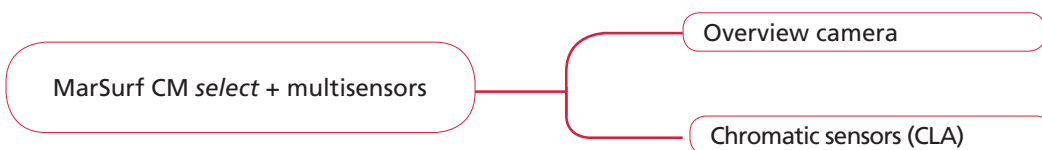

For the analysis of large measurement areas, the fast-scanning point sensor is a good choice. By switching to the MarSurf CM *select* technology, selected areas or precisely defined measurement points can then be scanned with top measurement precision. For the highest possible user-friendliness, both sensors are controlled from the same software.



MarSurf OPTICAL 3D PROFILOMETRY

YOUR ADVANTAGES

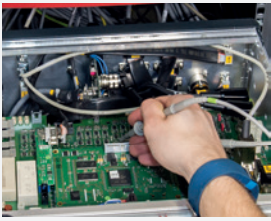
Mahr GmbH adopts a close orientation towards customer processes in its products, services, and innovation. From consulting to commissioning to ongoing support, we offer you comprehensive service from a single source. Our customers can rely at any time on our well-founded engineering experience and our high quality expectations. NanoFocus is certified to ISO 9001, OHSAS 18001 and ISO 14001.

Requirements Analysis	Engineering	Commissioning	After-Sales Service
			
Test measurements	Customer-specific adaptations	Installation	Maintenance
Consulting	Programming	Training	Repair
Requirement specification	Integration	System relocation	Support
			Training
			Calibration



Traceability of results and auditability

- Acceptance of all measurement systems in accordance with international standards and PTB-certified standards



Conformity with standards

- Active involvement in international committees for the standardization and norms of optical measurement processes
- Further development of our technology based on the latest standards
- Highest possible standards compliance of measurement results



Environmental consciousness

- Environmentally responsible materials, including supplies and consumables
- Energy-optimized measurement equipment
- Operational environmental management

Qualified customer service

- We offer comprehensive services with short and reliable response times that are individually tailored to the needs of your specific application.
- Continuous and regular maintenance of your measuring system by our trained service staff ensures its precision and durability.
- To ensure continuous smooth operation, we have designed a range of different service packages.

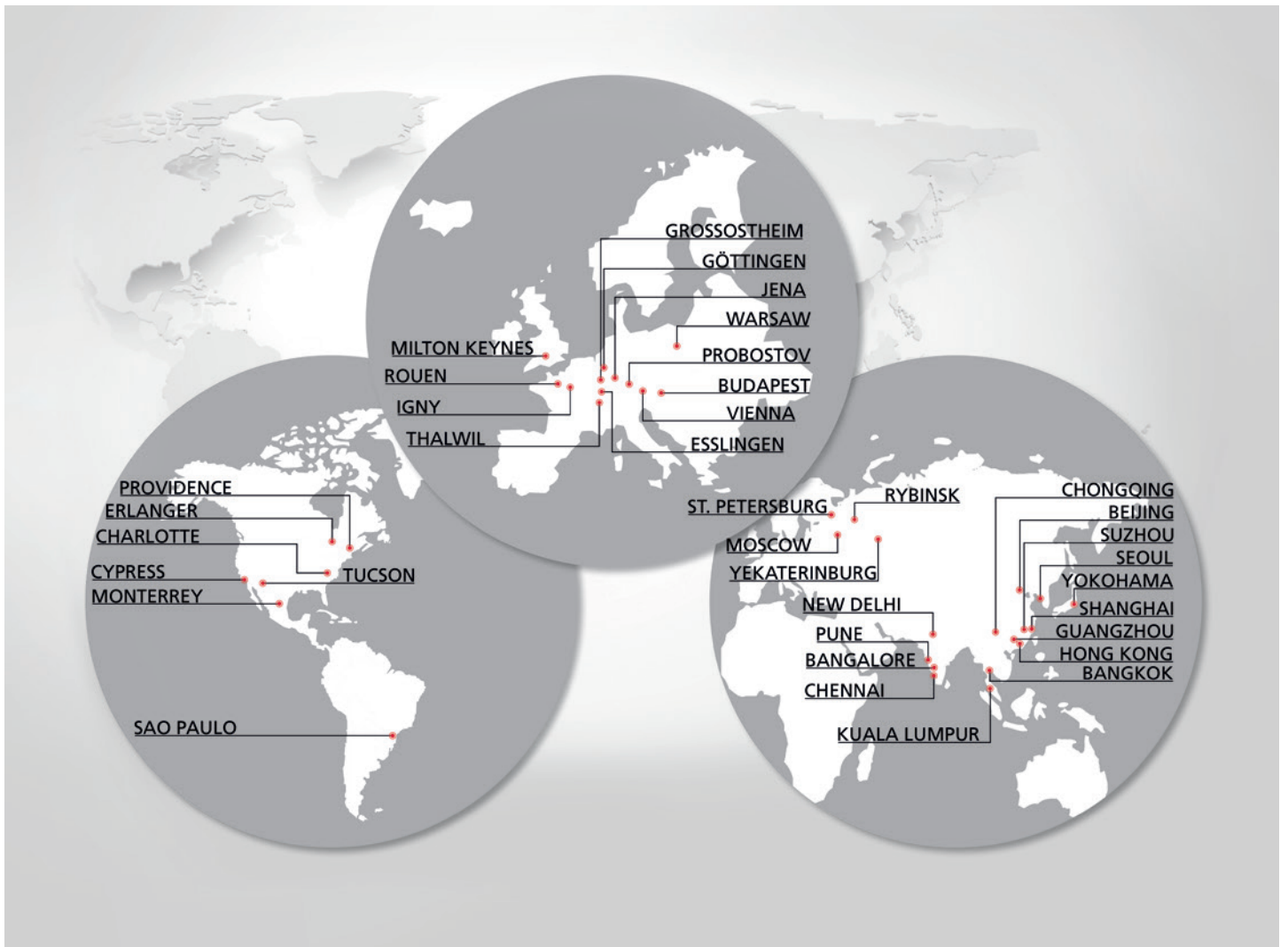

Partner for manufacturing companies worldwide.

Close to our customers.

Preferred distributor
Willrich Precision
866-945-5742 / sales@willrich.com



Mahr GmbH



© Mahr GmbH

We reserve the right to make changes to our products, especially due to technical improvements and further developments. All illustrations and technical data are therefore without guarantee. All list prices are the recommended retail prices.

3764323 | 04.2018

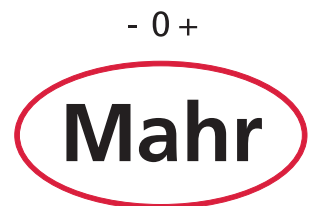

EXACTLY