

Starrett®

ELECTRONIC PRECISION HAND TOOLS

Micrometers

Calipers

Height Gages

Depth Gages

Indicators

Bore Gages

Testers



**WILLRICH PRECISION
INSTRUMENT**
THINK MEASUREMENT... THINK WILLRICH

Ph 866-945-5742 email:sales@willrich.com



TABLE OF CONTENTS

MICROMETERS	3-15	CALIPERS	16-21
Outside Micrometers (3)		HEIGHT GAGES	22-26
Anvil Micrometers (4)		DEPTH GAGES	27-29
Multi-Anvil (5)		INDICATORS	30-35
Sheet Metal Micrometers (6)		BORE GAGES	36-40
Tube Micrometers (7)		TESTERS	42-48
Blade Micrometers (8)			
Disc-Type Micrometers (9)			
Rounded Anvil Micrometers (10)			
Screw Thread Comparator Micrometers (11)			
Micrometer Heads (12)			
Bench Micrometers (13)			
Micrometer Depth Gage (13)			
3732 Micrometers (14)			
796.1 Micrometers (15)			

ICON LEGEND



Industry 4.0

Equipped with an output to allow for connection to wired or wireless data collection systems. Useful for quality control and tracking.



IP Protection

An IP number is composed of two numbers, the first referring to protection against solid objects and the second against liquids.

First number 6: High level protection against dust

Second number 7: Protection against submersion in water up to 1 meter of depth for 30 minutes



Wireless

Internal/ embedded wireless communication capability.

NEW AND IMPROVED!

BENEFITS/UPGRADES ON THE NEW ELECTRONIC MICROMETERS (WITH OUTPUT)

- IP67 Protection on the 733.1 1-4"/0-100mm, 756.1, 788.1, & 760.1
- Ergonomic frame design
 - Comfortable to use
 - Modern look
 - Insulated frame
- Upgraded Electronics
 - Larger readout display
 - Improved button feel
- Auto OFF after 20 minutes
- Advanced locking mechanism
- Equipped with RS232 output is ideal for use with DataSure Wireless Data Collection Systems or Multiplexer Input
- Competitive price point



ELECTRONIC MICROMETER

NEW!

733.1 ELECTRONIC MICROMETERS (WITH OUTPUT)

0-24"/0-600MM

The newly designed 733.1 is a full function electronic digital readout outside micrometer with IP67 level of protection for 0-4"/0-100mm ranges only.

The balanced and tapered frame provides comfortable and accurate measuring and gives the right feel during use.

733.1 Electronic Micrometers with Output - IP67

Friction Thimble, Spindle Lock, Shell and Thimble

Inch Grads			Metric Grads		
Cat. No.	EDP	Range	Cat. No.	EDP	Range
733.1XFL-1	72529	0-1"	733.1MEXFL-25	71032	0-25mm
733.1XFL-2	72630	1-2"	733.1MEXFL-50	72462	25-50mm
733.1XFL-3	72697	2-3"	733.1MEXFL-75	72528	50-75mm
733.1XFL-4	72698	3-4"	733.1MEXFL-100	71280	75-100mm

733.1 Electronic Micrometers with Output - Non IP67

733.1XFL-5	72699	4-5"	733.1MEXFL-125	71368	100-125mm
733.1XFL-6	72774	5-6"	733.1MEXFL-150	71574	125-150mm
733.1XFL-7	72775	6-7"	733.1MEXFL-175	71670	150-175mm
733.1XFL-8	72776	7-8"	733.1MEXFL-200	72003	175-200mm
733.1XFL-9	72777	8-9"	733.1MEXFL-225	72041	200-225mm
733.1XFL-10	72530	9-10"	733.1MEXFL-250	72124	225-250mm
733.1XFL-11	72536	10-11"	733.1MEXFL-275	72126	250-275mm
733.1XFL-12	72585	11-12"	733.1MEXFL-300	72128	275-300mm
733.1XFL-13	72586	12-13"	733.1MEXFL-325	72173	300-325mm
733.1XFL-14	72587	13-14"	733.1MEXFL-350	72174	325-350mm
733.1XFL-15	72590	14-15"	733.1MEXFL-375	72177	350-375mm
733.1XFL-16	72626	15-16"	733.1MEXFL-400	72178	375-400mm
733.1XFL-17	72627	16-17"	733.1MEXFL-425	72282	400-425mm
733.1XFL-18	72628	17-18"	733.1MEXFL-450	72449	425-450mm
733.1XFL-19	72629	18-19"	733.1MEXFL-475	72450	450-475mm
733.1XFL-20	72631	19-20"	733.1MEXFL-500	72465	475-500mm
733.1XFL-21	72632	20-21"	733.1MEXFL-525	72466	500-525mm
733.1XFL-22	72633	21-22"	733.1MEXFL-550	72470	525-550mm
733.1XFL-23	72634	22-23"	733.1MEXFL-575	72475	550-575mm
733.1XFL-24	72674	23-24"	733.1MEXFL-600	72527	575-600mm

Sets

Cat. No.	EDP	Range	Description
S733.1BXFLZ	60394	0-6"	Electronic micrometer set (set of 6) includes 733.1XFL-1 thru 733.1XFL-6 (IP67 0-4" only)
S733.1CXFLZ	60395	0-12"	Electronic micrometer set (set of 12) includes 733.1XFL-1 thru 733.1XFL-12 (IP67 0-4" only)

Cables and Accessories

Part No.	EDP	Description
795.1SCM	01124	Smart Cable to multiplexer
795.1SCKB	01125	USB Cable to PC (In focused window)
795.1SCU	01126	Smart Cable with USB keyboard output
PT99492	65650	Two 3-Volt Batteries, CR2032

All 733.1 Micrometers include a protective case.

All except 1" & 25mm sizes furnished with standards.

FEATURES AND SPECIFICATIONS

- IP67 protection against coolants, water, chips, dust and dirt (ranges 0-4"/0-100mm only)
- Equipped with an RS232 output - ideal for use with DataSure Wireless Data Collection System
- Starrett no-glare satin chrome finish on thimble and sleeve
- Micro-lapped carbide measuring faces
- Large, easy-to-read .275" (7mm) tall characters, high contrast LCD digital readout
- Balanced and tapered frame
- Extremely hard and stable one-piece spindle
- Auto Off after 20 minutes of nonuse
- Inch/millimeter conversion on English versions
- Smooth friction thimble for uniform pressure
- Measurement HOLD button
- Zero at any position
- Retain and return to true zero reading
- Spindle lock
- Data Output
- Resolution: .00005" (0.001mm)
- Accuracy +/- .0001" (+/- .002mm)
- PRESET button to install any reading at any position
- Ability to set minimum and maximum limits



MICROMETERS



NEW!

ANVIL MICROMETERS

714.1 ELECTRONIC INTERCHANGEABLE ANVIL OUTSIDE MICROMETERS (WITH OUTPUT)

0-24"/0-600MM

The newly designed 714.1 is very popular in machine or automotive repair shops and for all applications requiring a single micrometer with range greater than 1".

Each micrometer is equipped with a series of easily interchangeable anvils, thus providing the full range in steps of 1" or 25mm with a single micrometer. Suitable wrenches are furnished to make necessary adjustments.

The balanced and tapered frame provides comfortable and accurate measuring and gives the right feel during use.

714.1 Electronic Interchangeable Anvil Micrometer

Friction Thimble, Spindle Lock, Shell and Thimble

Inch Grads			Metric Grads		
Cat. No.	EDP	Range	Cat. No.	EDP	Range
714.1AAFLZ	72788	0-4"	714.1MEAFLZ	72801	0-100mm
714.1AFLZ	72789	2-6"	714.1MEAFZ	72802	50-150mm
714.1BFLZ	72790	6-9"	714.1MEGFLZ	72803	150-300mm
714.1GFLZ	72794	6-12"	714.1MEDFLZ	72804	300-400mm
714.1CFLZ	72795	9-12"	714.1MEEFLZ	72806	400-500mm
714.1DFLZ	72798	12-16"	714.1MEJFLZ	72807	500-600mm
714.1EFLZ	72799	16-20"			
714.1JFLZ	72800	20-24"			

Cables and Accessories

Part No.	EDP	Description
795.1SCM	01124	Smart Cable to multiplexer
795.1SCKB	01125	USB Cable to PC (In focused window)
795.1SCU	01126	Smart Cable with USB keyboard output
PT99492	65650	Two 3-Volt Batteries, CR2032

Adjusting wrenches furnished with each tool.

Micrometer furnished in protective case with 234 Standards.

FEATURES AND SPECIFICATIONS

- Equipped with an RS232 output - ideal for use with DataSure Wireless Data Collection System
- Starrett no-glare satin chrome finish on thimble and sleeve
- Large, easy-to-read .275" (7mm) tall characters, high contrast LCD digital readout
- Extremely hard and stable one-piece spindle
- Auto Off after 20 minutes of nonuse
- Inch/millimeter conversion on English versions
- Smooth friction thimble for uniform pressure
- Measurement HOLD button
- Zero at any position
- Retain and return to true zero reading
- Spindle lock
- Data Output
- Resolution: .00005" (0.001mm)
- Accuracy +/- .0001" (+/-0.002mm)
- PRESET button to install any reading at any position
- Ability to set minimum and maximum limits

**MICROMETERS**

MULTI ANVIL MICROMETERS

NEW!

790.1 ELECTRONIC MULTI-ANVIL MICROMETERS (WITH OUTPUT)

0-1"/0-25MM

The newly designed 790.1 will handle a wide variety of measurements impossible to obtain with regular micrometers, such as measuring the wall thickness of tubing, cylindrical walls from a hole or slot to an edge, many hard-to-reach locations, and thickness of screw heads, shoulder lengths, etc.

The balanced and tapered frame provides comfortable and accurate measuring and gives the right feel during use.

790.1 Electronic Multi-Anvil Micrometer With Round and Flat Anvils

Friction Thimble, Spindle Lock, Shell and Thimble

Inch Grads			Metric Grads		
Cat. No.	EDP	Range	Cat. No.	EDP	Range
790.1AFL-1	72859	0-1"	790.1MEAFL-25	72860	0-25mm

Cables and Accessories

Part No.	EDP	Description
795.1SCM	01124	Smart Cable to multiplexer
795.1SCKB	01125	USB Cable to PC (In focused window)
795.1SCU	01126	Smart Cable with USB keyboard output
PT99492	65650	Two 3-Volt Batteries, CR2032

Furnished with two hardened anvils-round anvil approximately .120 diameter and flat anvil approximately .125" thick V-Anvil only, order PT13017 (EDP 71399)

FEATURES AND SPECIFICATIONS



- Equipped with an RS232 output - ideal for use with DataSure Wireless Data Collection System
- Starrett no-glare satin chrome finish on thimble and sleeve
- Large, easy-to-read .275" (7mm) tall characters, high contrast LCD digital readout
- Extremely hard and stable one-piece spindle
- Auto Off after 20 minutes of nonuse
- Inch/millimeter conversion on English versions
- Smooth friction thimble for uniform pressure
- Measurement HOLD button
- Zero at any position
- Retain and return to true zero reading
- Spindle lock
- Data Output
- Resolution: .00005" (0.001mm)
- Accuracy +/- .0001" (+/-0.002mm)
- PRESET button to install any reading at any position
- Ability to set minimum and maximum limits



MICROMETERS



NEW!

SHEET METAL MICROMETERS

764.1 ELECTRONIC SHEET METAL MICROMETERS (WITH OUTPUT)

0-1"/0-25MM

The newly deigned 764.1 micrometer reaches over the edge of sheet metal to take measurements away from the edge toward the center. Also for gaging jobs where a deep throat micrometer is needed. Rounded anvil gives a point of contact for more accurate gaging; flat anvil also available.

The balanced and tapered frame provides comfortable and accurate measuring and gives the right feel during use.

764.1 Electronic Sheet Metal Micrometer, 6" Throat Depth with Round or Flat Anvil

Friction Thimble, Spindle Lock, Shell and Thimble

Inch Grads			Metric Grads		
Cat. No.	EDP	Range	Cat. No.	EDP	Range
764.1AXFL	72814	0-1", Round Anvil	764.1MEAXFL	72816	0-25mm, Round Anvil
764.1BXFL	72815	0-1", Flat Anvil			

Cables and Accessories

Part No.	EDP	Description
795.1SCM	01124	Smart Cable to multiplexer
795.1SCKB	01125	USB Cable to PC (In focused window)
795.1SCU	01126	Smart Cable with USB keyboard output
PT99492	65650	Two 3-Volt Batteries, CR2032

Packed one in a box without case
Flat anvil for Metric available upon request

FEATURES AND SPECIFICATIONS



- Equipped with an RS232 output - ideal for use with DataSure Wireless Data Collection System
- Starrett no-glare satin chrome finish on thimble and sleeve
- Large, easy-to-read .275" (7mm) tall characters, high contrast LCD digital readout
- Extremely hard and stable one-piece spindle
- Auto Off after 20 minutes of nonuse
- Inch/millimeter conversion on English versions
- Smooth friction thimble for uniform pressure
- Measurement HOLD button
- Zero at any position
- Retain and return to true zero reading
- Spindle lock
- Data Output
- Resolution: .00005" (0.001mm)
- Accuracy +/- .0001" (+/-0.002mm)
- PRESET button to install any reading at any position
- Ability to set minimum and maximum limits



TUBE MICROMETERS

NEW!

769.1 ELECTRONIC TUBE MICROMETERS (WITH OUTPUT)

0-1"/0-25MM

The newly designed 769.1 used for measuring the wall thickness of tubing and other parts with cylindrical walls. Also for measuring from a hole to an edge (minimum hole size 3/16").

The balanced and tapered frame provides comfortable and accurate measuring and gives the right feel during use.

769.1 Tube Micrometers					
Friction Thimble, Spindle Lock, Shell and Thimble					
Inch Grads			Metric Grads		
Cat. No.	EDP	Range	Cat. No.	EDP	Range
769.1AXFL	72817	0-1"	769.1MEAXFL	72818	0-25mm
Cables and Accessories					
Part No.	EDP	Description			
795.1SCM	01124	Smart Cable to multiplexer			
795.1SCKB	01125	USB Cable to PC (In focused window)			
795.1SCU	01126	Smart Cable with USB keyboard output			
PT99492	65650	Two 3-Volt Batteries, CR2032			

FEATURES AND SPECIFICATIONS



- Equipped with an RS232 output - ideal for use with DataSure Wireless Data Collection System
- Starrett no-glare satin chrome finish on thimble and sleeve
- Large, easy-to-read .275" (7mm) tall characters, high contrast LCD digital readout
- Extremely hard and stable one-piece spindle
- Auto Off after 20 minutes of nonuse
- Inch/millimeter conversion on English versions
- Smooth friction thimble for uniform pressure
- Measurement HOLD button
- Zero at any position
- Retain and return to true zero reading
- Spindle lock
- Data Output
- Resolution: .00005" (0.001mm)
- Accuracy +/- .0001" (+/-0.002mm)
- PRESET button to install any reading at any position
- Ability to set minimum and maximum limits

MICROMETERS



NEW!

BLADE MICROMETERS

786.1 ELECTRONIC MICROMETERS WITH NON-ROTATING SPINDLE (WITH OUTPUT)

0-5"/0-125MM

The newly designed 786.1 blade micrometer is used for fast and accurate measurements of circular form tools, diameter and depth of narrow grooves, slots, key ways, recesses, and depths between lands and fins.

The balanced and tapered frame provides comfortable and accurate measuring and gives the right feel during use.

MICROMETERS

786.1 Blade Micrometers

Non-rotating spindle, Shell and Thimble

Inch Grads			Metric Grads		
Cat. No.	EDP	Range	Cat. No.	EDP	Range
786.1P-1	72832	0-1"	786.1MEP-25	72829	0-25mm
786.1P-2	72834	1-2"	786.1MEP-50	72830	25-50mm
786.1P-3	72835	2-3"	786.1MEP-75	72831	50-75mm
786.1P-4	72836	3-4"	786.1MEP-100	72826	75-100mm
786.1P-5	72856	4-5"	786.1MEP-125	72827	100-125mm

Cables and Accessories

Part No.	EDP	Description
795.1SCM	01124	Smart Cable to multiplexer
795.1SCKB	01125	USB Cable to PC (In focused window)
795.1SCU	01126	Smart Cable with USB keyboard output
PT99492	65650	Two 3-Volt Batteries, CR2032

*Carbide face measuring surfaces available upon request

FEATURES AND SPECIFICATIONS



- Equipped with an RS232 output - ideal for use with DataSure Wireless Data Collection System
- Starrett no-glare satin chrome finish on thimble and sleeve
- Large, easy-to-read .275" (7mm) tall characters, high contrast LCD digital readout
- Attractive no glare black wrinkle finish on the frame
- Auto Off after 20 minutes of nonuse
- Inch/millimeter conversion on English versions
- Smooth friction thimble for uniform pressure
- Measurement HOLD button
- Zero at any position
- Retain and return to true zero reading
- .030" Blade Thickness
- Data Output
- Resolution: .00005" (0.001mm)
- Accuracy +/- .0001" (+/-0.002mm)
- PRESET button to install any reading at any position
- Ability to set minimum and maximum limits



DISC-TYPE MICROMETERS

NEW!

756.1 ELECTRONIC DISC-TYPE MICROMETER (WITH OUTPUT)

0-1"/0-25MM

The newly designed 756.1 is used to measure the thickness of work sections such as ribs, lands, fins, cutting edges on form tools, and chordal thickness of gear teeth. Because of their large anvil and spindle faces, the 1"/25mm sizes are also useful for measuring the thickness of sheet materials like paper, cardboard, rubber, and plastics. Now with IP67 level of protection.

The balanced and tapered frame provides comfortable and accurate measuring and gives the right feel during use.

756.1 Disc-Type Micrometer

Friction Thimble, Spindle Lock, Shell and Thimble

Inch Grads			Metric Grads		
Cat. No.	EDP	Range	Cat. No.	EDP	Range
756.1FL-1	72808	0-1"	756.1MEFL-25	72809	0-25mm

Cables and Accessories

Part No.	EDP	Description
795.1SCM	01124	Smart Cable to multiplexer
795.1SCKB	01125	USB Cable to PC (In focused window)
795.1SCU	01126	Smart Cable with USB keyboard output
PT99492	65650	Two 3-Volt Batteries, CR2032

FEATURES AND SPECIFICATIONS

- IP67 protection against coolants, water, chips, dust and dirt
- Equipped with an RS232 output - ideal for use with DataSure Wireless Data Collection System
- Starrett no-glare satin chrome finish on thimble and sleeve
- Large, easy-to-read .275" (7mm) tall characters, high contrast LCD digital readout
- Extremely hard and stable one-piece spindle
- Auto Off after 20 minutes of nonuse
- Inch/millimeter conversion on English versions
- Smooth friction thimble for uniform pressure
- Measurement HOLD button
- Zero at any position
- Retain and return to true zero reading
- Spindle lock
- Data Output
- Resolution: .00005" (0.001mm)
- Accuracy +/- .0001" (+/-0.002mm)
- PRESET button to install any reading at any position
- Ability to set minimum and maximum limits



MICROMETERS



NEW!

ROUNDED ANVIL MICROMETERS

788.1 ELECTRONIC MICROMETERS WITH ROUNDED ANVIL (WITH OUTPUT)

0-1"/0-25MM

The newly designed 788.1 are extremely useful for measuring the wall thickness of parts such as solid and split bearings, tubing, sleeves, collars, rings, various cylinders, and also measuring from the inside of a hole to an edge. The rounded anvil contacts the inside curved surface and a flat spindle for contacting the outside of the work, thus providing single point contact. This permits accurate gaging of curved surface thickness. Now with IP67 level of protection.

The balanced and tapered frame provides comfortable and accurate measuring and gives the right feel during use.

788.1 Electronic Micrometer

Friction Thimble, Spindle Lock, Shell and Thimble

Inch Grads			Metric Grads		
Cat. No.	EDP	Range	Cat. No.	EDP	Range
788.1XFL	72858	0-1"	788.1MEXFL	72857	0-25mm

Cables and Accessories

Part No.	EDP	Description
795.1SCM	01124	Smart Cable to multiplexer
795.1SCKB	01125	USB Cable to PC (In focused window)
795.1SCU	01126	Smart Cable with USB keyboard output
PT99492	65650	Two 3-Volt Batteries, CR2032

FEATURES AND SPECIFICATIONS

- IP67 protection against coolants, water, chips, dust and dirt
- Equipped with an RS232 output - ideal for use with DataSure Wireless Data Collection System
- Starrett no-glare satin chrome finish on thimble and sleeve
- Large, easy-to-read .275" (7mm) tall characters, high contrast LCD digital readout
- Extremely hard and stable one-piece spindle
- Auto Off after 20 minutes of nonuse
- Inch/millimeter conversion on English versions
- Smooth friction thimble for uniform pressure
- Measurement HOLD button
- Zero at any position
- Retain and return to true zero reading
- Spindle lock
- Data Output
- Resolution: .00005" (0.001mm)
- Accuracy +/- .0001" (+/-0.002mm)
- PRESET button to install any reading at any position
- Ability to set minimum and maximum limits



MICROMETERS



SCREW THREAD MICROMETERS

NEW!

760.1 ELECTRONIC SCREW THREAD COMPARATOR MICROMETER (WITH OUTPUT)

0-1"/0-25MM

The newly designed 760.1 micrometer is ideal for quick comparisons of thread accuracy in screw cutting operations, measuring in small grooves or recesses where regular micrometers cannot be used, and for many other applications. Now with IP67 level of protection.

The balanced and tapered frame provides comfortable and accurate measuring and gives the right feel during use.

FEATURES AND SPECIFICATIONS

- IP67 protection against coolants, water, chips, dust and dirt
- Equipped with an RS232 output - ideal for use with DataSure Wireless Data Collection System
- Starrett no-glare satin chrome finish on thimble and sleeve
- Large, easy-to-read .275" (7mm) tall characters, high contrast LCD digital readout
- Extremely hard and stable one-piece spindle
- Auto Off after 20 minutes of nonuse
- Inch/millimeter conversion on English versions
- Smooth friction thimble for uniform pressure
- Measurement HOLD button
- Zero at any position
- Retain and return to true zero reading
- Spindle lock
- Data Output
- Resolution: .00005" (0.001mm)
- Accuracy +/- .0001" (+/-0.002mm)
- PRESET button to install any reading at any position
- Ability to set minimum and maximum limits



MICROMETERS

760.1 Electronic Micrometer					
Friction Thimble, Spindle Lock, Shell and Thimble					
Inch Grads			Metric Grads		
Cat. No.	EDP	Range	Cat. No.	EDP	Range
760.1FL	72810	0-1"	760.1MEFL	72811	0-25mm
Cables and Accessories					
Part No.	EDP	Description			
795.1SCM	01124	Smart Cable to multiplexer			
795.1SCKB	01125	USB Cable to PC (In focused window)			
795.1SCU	01126	Smart Cable with USB keyboard output			
PT99492	65650	Two 3-Volt Batteries, CR2032			

*Note: Does not measure pitch diameter.



NEW!

MICROMETER HEADS

762.1 ELECTRONIC MICROMETER HEADS

0-2"/0-50MM

MICROMETERS

762.1 Electronic Micrometer Head					
Friction Thimble, Spindle Lock, Shell and Thimble					
Inch Grads			Metric Grads		
Cat. No.	EDP	Range	Cat. No.	EDP	Range
762.1XFL	72786	0-1"	762.1MEXFL-25	72783	0-25mm
762.1NXRL	72785	0-1" (non-rotating)	762.1MEXFL-50	72784	0-50mm
762.1XFL-2	72787	0-2"			

Cables and Accessories		
Part No.	EDP	Description
795.1SCM	01124	Smart Cable to multiplexer
795.1SCKB	01125	USB Cable to PC (In focused window)
795.1SCU	01126	Smart Cable with USB keyboard output
PT99492	65650	Two 3-Volt Batteries, CR2032

FEATURES AND SPECIFICATIONS



- Equipped with an RS232 output - ideal for use with DataSure Wireless Data Collection System
- Starrett no-glare satin chrome finish on thimble and sleeve
- Large, easy-to-read .275" (7mm) tall characters, high contrast LCD digital readout
- Extremely hard and stable one-piece spindle
- Auto Off after 20 minutes of nonuse
- Inch/millimeter conversion on English versions
- Smooth friction thimble for uniform pressure
- Measurement HOLD button
- Zero at any position
- Retain and return to true zero reading
- Spindle lock
- Data Output
- Resolution: .00005" (0.001mm)
- Accuracy +/- .0001" (+/-0.002mm)
- PRESET button to install any reading at any position
- Ability to set minimum and maximum limits



BENCH MICROMETERS

NEW!

777.1 ELECTRONIC BENCH MICROMETERS (WITH OUTPUT)

0-1"/0-25MM

Especially suitable for precision measurements where the work must be brought to the gage. Work is staged between the anvil and spindle on an adjustable table, which can be raised to a selected height and locked in position by turning a knurled thumb screw on the back of the base. Made of cast iron with black finish, the base is heavily proportioned to sustain gage accuracy and assure stability in use. It stands on three machined pads.

777.1 Bench Micrometer					
Friction Thimble, Spindle Lock, Shell and Thimble					
Inch Grads			Metric Grads		
Cat. No.	EDP	Range	Cat. No.	EDP	Range
777.1XFLZ	72822	0-1"	777.1MEXFLZ	72819	0-25mm

Cables and Accessories		
Part No.	EDP	Description
795.1SCM	01124	Smart Cable to multiplexer
795.1SCKB	01125	USB Cable to PC (In focused window)
795.1SCU	01126	Smart Cable with USB keyboard output
PT99492	65650	Two 3-Volt Batteries, CR2032



749.1 ELECTRONIC MICROMETER DEPTH GAGE (WITH OUTPUT)

0-12"/0-300MM

This depth micrometer has a wide 0-12"/0-300mm range for measuring the depth of most holes slots, shoulders, and projections.

A base shape design that will automatically position the fingers so the base will be held in place evenly.

749.1 Depth Micrometer					
Spindle Lock, Shell and Thimble					
Inch Grads			Metric Grads		
Cat. No.	EDP	Range	Cat. No.	EDP	Range
749.1BZ-6RL	72780	0-6"	749.1MEBZ-150	72781	0-150mm
749.1BZ-12RL	72779	0-12"	749.1MEBZ-300	72782	0-300mm

Cables and Accessories		
Part No.	EDP	Description
795.1SCM	01124	Smart Cable to multiplexer
795.1SCKB	01125	USB Cable to PC (In focused window)
795.1SCU	01126	Smart Cable with USB keyboard output
PT99492	65650	Two 3-Volt Batteries, CR2032



FEATURES AND SPECIFICATIONS



- Equipped with an RS232 output - ideal for use with DataSure Wireless Data Collection System
- Starrett no-glare satin chrome finish on thimble and sleeve
- Large, easy-to-read .275" (7mm) tall characters, high contrast LCD digital readout
- Extremely hard and stable one-piece spindle
- Auto Off after 20 minutes of nonuse
- Inch/millimeter conversion on English versions
- Smooth friction thimble for uniform pressure
- Measurement HOLD button
- Zero at any position
- Retain and return to true zero reading
- Spindle lock
- Data Output
- Resolution: .00005" (0.001mm)
- Accuracy +/- .0001" (+/-0.002mm)
- PRESET button to install any reading at any position
- Ability to set minimum and maximum limits

FEATURES AND SPECIFICATIONS



- Equipped with an RS232 output - ideal for use with DataSure Wireless Data Collection System
- Starrett no-glare satin chrome finish on thimble and sleeve
- Large, easy-to-read .275" (7mm) tall characters, high contrast LCD digital readout
- Extremely hard and stable one-piece spindle
- Auto Off after 20 minutes of nonuse
- Inch/millimeter conversion on English versions
- Measurement HOLD button
- Zero at any position
- Retain and return to true zero reading
- Spindle lock
- Data Output
- Resolution: .00005" (0.001mm)
- Accuracy +/- .0001" (+/-0.002mm)
- PRESET button to install any reading at any position
- Ability to set minimum and maximum limits
- Base Length 4"/rod diameter 5/32"
- Ground and hardened base

MICROMETERS



OUTSIDE MICROMETERS

796.1 ELECTRONIC MICROMETERS (NON OUTPUT)

0-4" / 0-100MM

The 796.1 Micrometer offering includes measuring ranges of 0-4" / 0-100mm. All are IP67 protected against coolant, water, chips, dirt, and dust.

796.1 Electronic Micrometers without Output / Friction Thimble

Cat. No.	EDP	Range
796.1XFL-1	01104	0-1"
796.1XFL-2	01105	1-2"
796.1XFL-3	01106	2-3"
796.1XFL-4	01107	3-4"

796.1 Electronic Micrometers without Output / Ratchet Thimble

Cat. No.	EDP	Range
796.1XRL-1	01116	0-1"
796.1XRL-2	01117	1-2"
796.1XRL-3	01118	2-3"
796.1XRL-4	01119	3-4"
796.1MXRL-25	01120	0-25mm
796.1MXRL-50	01121	25-50mm
796.1MXRL-75	01122	50-75mm
796.1MXRL-100	01123	75-100mm

*All 796.1 Micrometers include a protective case.

*All except 1" & 25mm furnished with standards.

FEATURES AND SPECIFICATIONS

- Large, easy-to-read .275" (7mm) tall characters, high contrast LCD digital readout
- Starrett no-glare satin chrome finish on thimble and sleeve
- Balanced and tapered frame
- Extremely hard and stable one-piece spindle
- Micro-lapped carbide measuring faces
- Auto OFF after 20 minutes of nonuse
- Inch/millimeter conversion on English versions
- Measurement HOLD button
- Zero at any position
- Retain and return to true zero reading
- Resolution: .00005" (0.001mm)
- Accuracy: $\pm .0001"$ ($\pm 0.002\text{mm}$)



796.1XFL-2



796.1XFL-1



ELECTRONIC MICROMETERS

3732 ELECTRONIC MICROMETERS (NON OUTPUT)

0-6"/0-150MM

The 3732 Electronic Micrometer is a full-featured precision measuring tool built with customary Starrett quality and workmanship. The 3732 includes a large, easy-to-read, high contrast LCD digital readout for clear readings. With its auto OFF functionality, smooth friction thimble for uniform pressure, and balanced frame design, the 3732 provides comfortable and accurate measuring.

3732 Inch/Metric Micrometers without Output							
Cat. No.	EDP	Range		Resolution		Accuracy	
		in	Approx. mm	in	mm	in	mm
3732XFL-1	12268	0-1	0-25.4	.0001"	0.001	± .0001"	± 0.002
3732XFL-2	12269	1-2	25.4-50.8	.0001"	0.001	± .0001"	± 0.003
3732XFL-3	12270	2-3	50.8-76.2	.0001"	0.001	± .00015"	± 0.004
3732XFL-4	12271	3-4	76.2-101.6	.0001"	0.001	± .00015"	± 0.004
3732XFL-5	12272	4-5	101.6-127	.0001"	0.001	± .00015"	± 0.004
3732XFL-6	12273	5-6	127-152.4	.0001"	0.001	± .00015"	± 0.004

3732 Metric/Inch Micrometers without Output							
Cat. No.	EDP	mm		mm		mm	
		mm	Approx. in	mm	in	mm	in
3732MEXFL-25	12274	0-25	0-.984	0.001	.0001"	± 0.002	± .0001"
3732MEXFL-50	12275	25-50	.984-1.968	0.001	.0001"	± 0.003	± .0001"
3732MEXFL-75	12276	50-75	1.968-2.953	0.001	.0001"	± 0.004	± .0001"
3732MEXFL-100	12277	75-100	2.953-3.937	0.001	.0001"	± 0.004	± .0001"
3732MEXFL-125	12278	100-125	3.937-4.921	0.001	.0001"	± 0.004	± .0001"
3732MEXFL-150	12279	125-150	4.921-5.905	0.001	.0001"	± 0.004	± .0001"

3732 Inch/Metric Micrometer Sets without Output				
Cat. No.	EDP	in	mm	Description
S3732BXFLZ	12726	0-1 to 3-4	0-25.4 to 76.2-101.6	0 to 4 inch set of four micrometers in metal case
S3732CXFLZ	12727	0-1 to 5-6	0-25.4 to 101.6-152.4	0 to 6 inch set of six micrometers in metal case

3732 Micrometer Accessories		
Part No.	EDP	Description
PT99492	65650	CR2032 3-volt battery for 3732 Micrometers

All electronic micrometers include protective case

FEATURES AND SPECIFICATIONS

- Auto OFF after 30 minutes of nonuse
- .250" (6.35mm) spindle diameter
- No-glare black wrinkle finish on frame
- No-glare satin chrome finish on thimble and sleeve
- Ring-type knurled lock nut for quick and sure locking
- English/Metric models feature inch graduations on shell and thimble
- Metric/English (ME) models have mm graduations on shell and thimble
- Instant inch/millimeter conversion
- Measurement HOLD button
- Ability to zero tool at any position
- Ability to retain and return to the true zero reading of the micrometer
- PRESET button to install any reading at any position
- Includes one 3-volt battery for over one year of normal usage



CARBON FIBER CALIPERS

5000, 5001 AND 5002 CARBON FIBER CALIPERS

0-40"

- Carbon fiber construction significantly reduces weight, improving maneuverability
- Titanium coated stainless steel outside measurement jaws for long life and superior flatness
- Coolant resistant
- Two preset modes, REF I and REF II, allow setting one mode to a setting master and a second to a zero setting
- Full-featured, sophisticated electronics with RS232 output
- Will also transmit to PC through cable

FEATURES AND SPECIFICATIONS

- Equipped with an RS232 output - ideal for use with DataSure Wireless Data Collection System
- CR2032 lithium battery included
- Clamping screw
- Protective wooden case
- Resolution: .0005"/0.01mm



5000 AND 5002 ONLY

- mm/inch mode button
- On/Off button
- Hold feature will freeze the display when in REF I or REF II mode

5001 ONLY

- Mode and Set buttons
- Min/Max mode displays values referenced from the preset value of the REF mode the tool is in when entering MIN/MAX
- Tolerance mode to set upper and lower measurement tolerances
- Larger display with more information



5002BZ-16/400 with PT06138 Step Contacts



5002BZ-24/600 with PT06139 Conical Contacts



5002BZ-40/1000 with PT06137 Disc Contacts



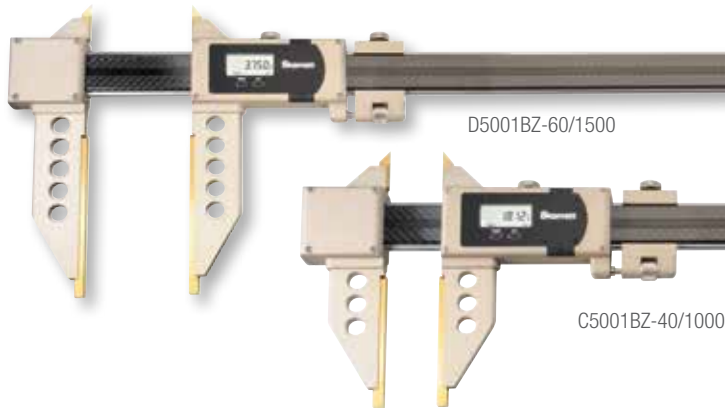
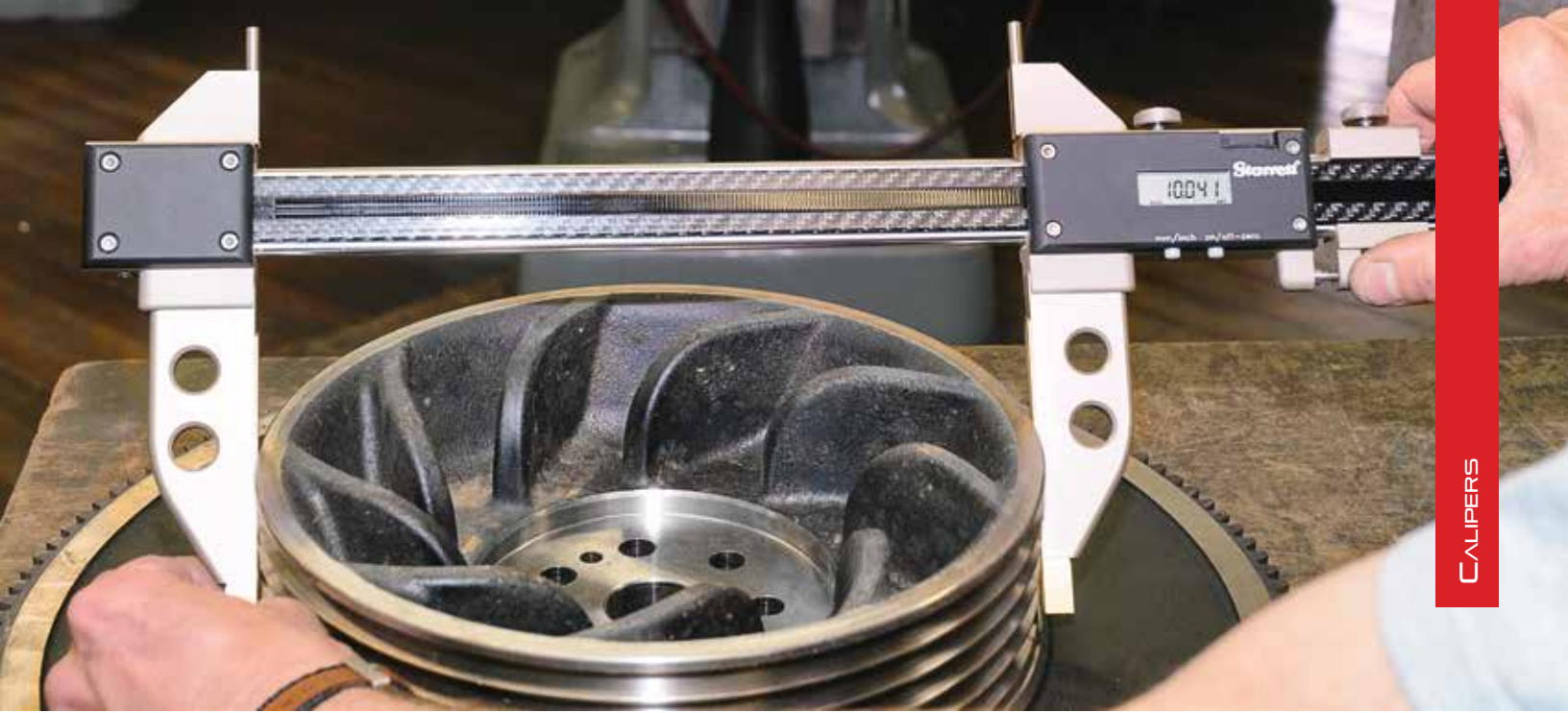

5000 Carbon Fiber Calipers

Cat. No.	EDP	Outside	Weight	Jaw Depth	Measuring Capacities	
					Inside (w/jaws)	Inside (w/top pins)
B5000BZ-20/500	14571	0-20" (0-500mm)	2.43lb (1.10kg)	4.921" (125mm)	.787-20" (20-500mm)	.394-20" (10-500mm)
B5000BZ-24/600	14572	0-24" (0-600mm)	2.56lb (1.16kg)	4.921" (125mm)	.787-24" (20-600mm)	.394-24" (10-600mm)
B5000BZ-40/1000	14573	0-40" (0-1000mm)	3.09lb (1.40kg)	4.921" (125mm)	.787-40" (20-1000mm)	.394-40" (10-1000mm)

5001 Carbon Fiber Calipers

Cat. No.	EDP	Outside	Weight	Jaw Depth
C5001BZ-40/1000	14574	0-40" (0-1000mm)	5.51lb (2.50kg)	5.906" (150mm)
D5001BZ-60/1500	14575	0-60" (0-1500mm)	7.28lb (3.30kg)	7.875" (200mm)

5002 Carbon Fiber Calipers

Cat. No.	EDP	Outside	Weight
5002BZ-16/400	14576	0-16" (0-400mm)	1.65lb (0.75kg)
5002BZ-24/600	14577	0-24" (0-600mm)	1.98lb (0.90kg)
5002BZ-40/1000	14578	0-40" (0-1000mm)	3.31lb (1.50kg)

Accessories for 5002 Carbon Fiber Calipers

Part No.	EDP	Description
PT06137	12829	Disc Contacts
PT06138	12830	Step Contacts
PT06139	12831	Cone Contacts

Data Collection

Part No.	EDP	Description
798SCKB	69889	USB Cable to PC (In focused window)





ELECTRONIC CALIPERS

5005 ELECTRONIC LONG JAW CALIPERS

0-24"/0-600MM

The 5005 Electronic Calipers are built with extra long, 12" (300mm) jaws ideal for applications requiring precise O.D. or I.D. measurement in tight spaces that standard calipers cannot reach.

FEATURES AND SPECIFICATIONS

- Equipped with an RS232 output - ideal for use with DataSure Wireless Data Collection System
- Hardened stainless steel construction for long life
- Tight, smoothly fitted slides for maximum accuracy and easy adjustment
- Coolant resistant
- Lock nut to hold measurements
- Fine adjustment thumbwheel
- Inch/mm conversion
- Ability to set ZERO at any position
- Two preset modes to install any reading at any point
- Full-featured, sophisticated electronics with proximity output
- Will also transmit to PC through cable
- CR2032 lithium battery included
- Large easy-to-read display with resolution of 0.0005"/0.01mm
- Packed in a wood case
- Computers with Excel use 798SCKB USB Cable to PC
- Computers running SPC Data Collection use 798SCU Smart Cable to USB



INDUSTRY 4.0



F5005BZ-24/600

5005 Electronic Calipers

Cat. No.	EDP	Range	Jaw Depth
F5005BZ-24/600	14588	0-24" (0-600mm)	12" (300mm)





ELECTRONIC CALIPERS

5006 ELECTRONIC GROOVE CALIPERS

FEATURES AND SPECIFICATIONS

- Equipped with an RS232 output - ideal for use with DataSure Wireless Data Collection System
- Standard Measuring Tip Diameter: .118" (3mm)
- Two Preset Modes
- Hold Feature will freeze the display when it is in preset mode
- On/Off Button
- CR2032 lithium battery included
- Includes wooden case
- Resolution: .0005" (0.01mm)
- Generous diameter and jaw depth capacities
- Ideal for measuring internal and external grooves on large workpieces
- Hardened stainless steel construction
- Coolant resistant



5006BZ-14/350



INDUSTRY 4.0

5006 Electronic Groove Caliper	
Cat. No.	EDP
5006BZ-14/350	14589

Data Collection		
Part No.	EDP	Description
798SCKB	69889	USB Cable to PC (In focused window)

Specifications		
	Groove Measuring Range	Max. Depth
Outside	0-12.5" (0-318mm)	3.937" (100mm)
Inside	1.654-15" (42-381mm)	3.7" (94mm)



ELECTRONIC CALIPERS

798 ELECTRONIC CALIPERS

0-12"/0-300MM

The 798 Electronic Caliper features a large, easy-to-read, high contrast LCD readout. It includes IP67 protection against coolants, water, chips, dust and dirt often found in machine shop environments. Its induction type linear encoder system and Inch/millimeter conversion makes this Starrett precision measuring tool the right choice for any job.

798 Electronic Calipers

Cat. No.	EDP	Range	Description
798B-6/150	12521	0-6" (150mm)	Caliper with output
798B-6/150 W/SLC	12522		Caliper with output
798BX-6/150	12782		Caliper with output
798A-6/150	20798		Caliper without output
798B-8/200	12523	0-8" (200mm)	Caliper with output
798B-8/200 W/SLC	12524		Caliper with output
798A-8/200	20799		Caliper without output
798B-12/300	12525	0-12" (300mm)	Caliper with output
798B-12/300 W/SLC	12526		Caliper with output
798A-12/300	20800		Caliper without output

Special Large Jaw for Brake Calipers

EC799AR-6/150	73602	0-6" (150mm)	Caliper without output
---------------	-------	--------------	------------------------

Accessories, Cables and Case Information for 798 Electronic Calipers

Cat. No.	EDP	Description
798SCM	69894	Smart Cable to multiplexer
798SCU	73321	Smart Cable to USB
798SCKB	69889	USB Cable to PC (In focused window)
PT26151	64440	Center distance attachment
PT22431	64640	Depth attachment
PT63388	72517	Computer interface cable to PC (USB) with driver CD
PT63329-1	12733	Replacement non-contact computer interface cable to PC (USB)
PT99492	65650	Two 3-Volt batteries, CR2032
723ZZ-6/722ZZ-6	57070	Deluxe padded case for 0-6" (150mm) calipers
950	63878	Finished wood case for 0-8" (200mm) calipers
946	56695	Finished wood case for 0-12" (300mm) calipers

*Includes redemption card for Standard Letter of Certification (SLC).

FEATURES

- IP67 level of protection
- Equipped with an RS232 output - ideal for use with DataSure Wireless Data Collection System
- Fine adjustment
- Hardened stainless steel measuring surfaces
- Large, easy-to-read, high-contrast LCD digital readout
- Induction type linear encoder system
- RS232 output
- Heavy-duty bar and slide
- Slide lock
- One 3-volt battery for over one year of normal usage
- In/mm conversion
- Zero at any position
- Auto off after 30 minutes of nonuse
- Reactivation of display with no loss of position



INDUSTRY 4.0

Approximate Jaw Depths for 798 Electronic Calipers

	6" (150mm)	8" (200mm)	12" (300mm)
Outside	1-1/2" (38mm)	1-7/8" (47.6mm)	2-1/2" (63.5mm)
Inside	5/8" (16mm)	3/4" (19mm)	3/4" (19mm)



ELECTRONIC CALIPERS

EC799 ELECTRONIC CALIPERS

0-40"/0-1000MM

The EC799 Electronic Caliper is light, comfortable, easy-to-use, and constructed with features that have made Starrett slide calipers the machinist's first choice for many years. Output now available on B models.

The EC799 offers a slim, streamlined profile, a large, clear, easy-to-read LCD display, long battery life, and function buttons for zero and inch/mm.

FEATURES

- Equipped with an RS232 output - ideal for use with DataSure Wireless Data Collection System
- Lightweight, ergonomic design
- Inch/millimeter conversion reads .0005" or 0.01mm
- Easy access to the single, long-life battery
- Last measuring position retained when shut off
- Hardened stainless steel body for long life
- Fine adjustment thumb wheel
- Lock screw to hold the slide in position
- Resolution is .0005" (0.01mm)
- Zero at any position
- Protective case

EC799 Electronic Slide Calipers			
Cat. No.	EDP	Range in	mm
EC799A-6/150	00142	0-6	0-150
EC799A-6/150 W/SLC*	72665		
EC799B-6/150	00143		
EC799B-6/150 W/SLC*	00144		
EC799A-8/200	00145	0-8	0-200
EC799A-8/200 W/SLC*	72674		
EC799B-8/200	00146		
EC799B-8/200 W/SLC*	00147	0-12	0-300
EC799A-12/300	00148		
EC799A-12/300 W/SLC*	72673		
EC799B-12/300	00149		
EC799B-12/300 W/SLC*	00150		

799 Extended Slide Calipers without Output			
Cat. No.	EDP	Range in	mm
799AZ-24/600	11978	0-24	0-600
799AZ-40/1000	11979	0-40	0-1000

Accessories, Cables and Case Information for 799 Electronic Calipers		
Cat. No.	EDP	Description
EC799BSCM	46000	Smart Cable to multiplexer
EC799BSCU	46002	Smart Cable to USB
EC799BSCKB	46001	Smart Cable to USB keyboard
PT26151	64440	Center distance attachment
PT22431	64640	Depth attachment for 6", 9" and 150mm calipers
PT99492	65650	3-volt battery; CR2032
723ZZ-6/72ZZZ-6	57070	Deluxe padded case for 0-6" (150mm) calipers
950	63878	Finished wood case for 0-8" (200mm) calipers
946	56695	Finished wood case for 0-12" (300mm) calipers

* Includes redemption card for Standard Letter of Certification (SLC).

Approximate Jaw Depths for 799 Electronic Calipers					
	6" (150mm)	8" (200mm)	12" (300mm)	24" (600mm)	40" (1000mm)
Outside	1-1/2" (38mm)	2" (50.8mm)	2-1/2" (63.5mm)	4" (100mm)	6" (150mm)
Inside	5/8" (16mm)	3/4" (19mm)	23/32" (18.3mm)	11/16" (17.46mm)	11/16" (17.46mm)

6", 8" AND 12" CALIPERS ONLY

- Large, easy-to-read .32" tall characters, high contrast LCD digital readout
- Auto OFF after 5 minutes of nonuse
- Linear accuracy meets DIN862
- Integrated depth rod



EXTENDED RANGE 24" AND 40" CALIPERS

- Preset and hold feature
- Minimum and maximum limits set
- I.D. jaw dimension is .800"/20.32mm
- LCD characters are .50" high
- Auto off after 30 minutes of nonuse



ELECTRONIC HEIGHT GAGES

2000 ALTISSIMO® ELECTRONIC HEIGHT GAGES

0-24"/600MM

Altissimo® Electronic Height Gages are innovative, easy-to-use, and loaded with Starrett-exclusive functions for easy-to-program measuring routines that run smoothly and reliably.



FEATURES

- Equipped with an RS232 output - ideal for use with DataSure Wireless Data Collection System
- A unique, ergonomically shaped base, hardened and ground, that fits your grip just right to easily move the gage and press the hot key
- Hot key allows you to select measuring results on the fly
- 0-24" Measuring Range
- Smart probe that can measure I.D. or O.D. without attachments
- Electronically adjusted probe force
- Large, easy-to-read interactive LCD with unique scanning meter for monitoring probe position
- Electronically adjustable beeper volume
- Bold screen icons indicate the current routine
- Three electronically adjustable resolutions
- Retains the last calibrated diameter of the measuring probe, even after the gage is shut down
- Dynamic bi-directional probing with point and scan modes
- Easy operation with speed wheel, which also has fine-adjust feature
- Locking mechanism for scribing
- Five measurement modes: (ID/OD, Center, TIR, Max/Min, Continuous Display)
- Instant inch/millimeter conversion
- Two selectable Datums and Presets
- Auto Power Off after two hours with retention of probe calibration
- Automatic calculation of eight measurement routines:
 - Center
 - Diameter
 - Height
 - Max
 - Min
 - TIR
 - Distance to last feature
 - Distance between last two points
- Rechargeable NiMH batteries with 100 hours of continuous life
- Seven setup functions:
 - Probe Calibration (2)
 - Beeper Volume
 - Display Resolution
 - Probe Force Adjustment
 - Printer On/Off
 - Force Calibration
- Optional probe kit features a variety of probes for many applications
- Gages include carbide probe, probe holder and probe calibration block
- Starrett capacitive measurement system ensures the accuracy and reliability you expect
- Excellent value – loaded with features and competitively priced

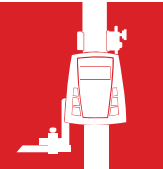



Large, easy-to-view /understand display shows the diameter of a hole or boss



Display showing TIR



Interactive LCD with unique scanning meter for easy probe position viewing

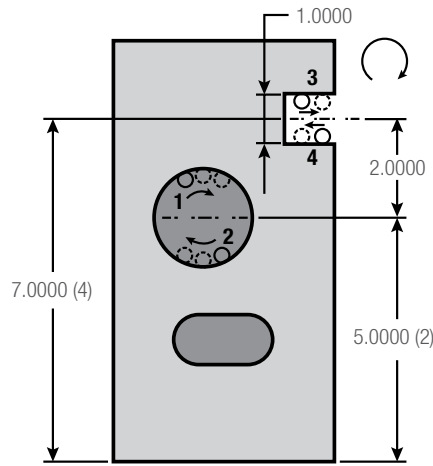

Altissimo includes many routines including diameter of a bore (1 and 2), width of a slot or a rib (3 and 4), distance from datum to center of a hole or slot and distance between features

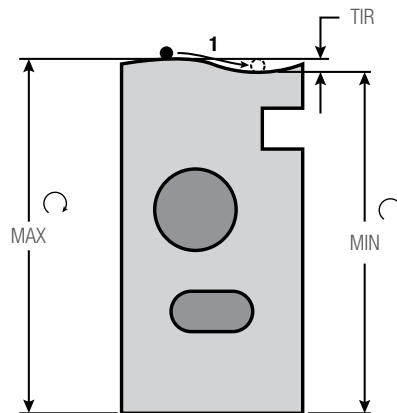

TIR mode can measure the high or low point of a diameter or other surface. The datum can then be set to the max or min value.

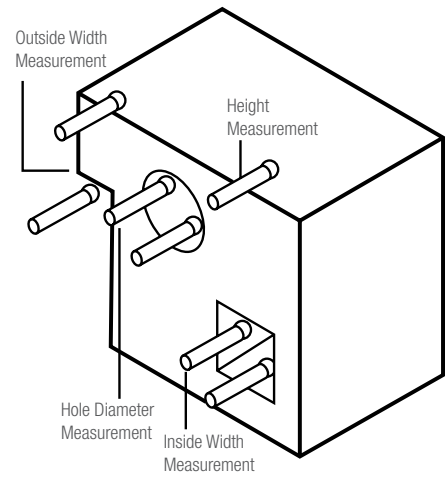

Specifications	
Measuring Range	24"/600mm (Extendible to 30"/750mm by rotating the probe holder 180°)
Resolution	.0001"/.0005"/.001" (0.002mm/0.01mm/0.02mm)
Accuracy	±.0003" (0.008mm)
Repeatability	±.0002" (±0.002mm)
Power Source	NiMH Rechargeable Batteries (120V AC/60Hz Charger/Adapter included). Operation time: 100+ hours, Recharging time: 10 hours
Included	.1875"/4.8mm Dia. Carbide Probe, Probe Holder
Accessories	AC Charger/Adapter, Probe Calibration Block
Dimensions	Length 11" (279mm), Width 7-3/4" (197mm), Height 36-1/2" (927mm)
Weight	40 lb (18 kg)
Perpendicularity	.0004" (0.010mm)



ELECTRONIC HEIGHT GAGES

2000 ALTISSIMO® ELECTRONIC HEIGHT GAGES



Altissimo Electronic Height Gages with Standard Components

Cat. No.	EDP	Description
2000-24	67008	Height Gage
PT27937	67009	Carbide Probe .1875" (4.8mm) Dia. (Standard)
PT27940	67010	Probe Holder (Standard)
PT27944	67011	Probe Calibration Block (Standard)

Accessories for Altissimo Electronic Height Gages

Part No.	EDP	Description
S2000AZ	66997	Accessory Set Includes:
PT27948	67012	Probe Tip, 5-Way Adapter
PT23942	65255	.040" (1mm) Carbide Contact Point
PT23914	64222	.078" (2mm) Carbide Contact Point
PT23943	65256	.120" (3mm) Carbide Contact Point
PT27952	67013	Contact Wrench
PT27945	67014	.400" (10.2mm) Cylindrical Probe
PT27950	67015	Circular Carbide Scriber
PT27949	67016	Depth Gage Attachment
PT27946	67017	Holder for Dovetail Indicators
PT62011	67018	Replacement Battery Pack, NiMH 6V
PT62015	67002	Power Supply Charger for USA and Canadian Configuration
PT62130	67003	Power Supply Charger for United Kingdom Configuration
PT62131	67004	Power Supply Charger for European Configuration
2000SCM	69907	Cable to 7612 or 7613 Multiplexer
2000SCKB	69908	USB Cable to PC (In focused window)
2000SCU	29728	Cable to PC Running Data Collection SPC Software - USB

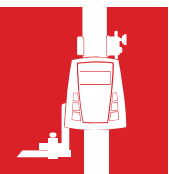

ELECTRONIC HEIGHT GAGES

3754 ELECTRONIC HEIGHT GAGES

The 3754 Electronic Height Gage is a full featured, versatile and economic solution for most height measurement applications. All measuring information from these tools can be entered directly into Starrett Data Collection Systems for analysis, data collection and hard copy documentation. It is available in 0-12" and 0-24" ranges.



FEATURES

- Equipped with an RS232 output - ideal for use with DataSure Wireless Data Collection System
- Large (.380"/9.65mm), easy-to-read LCD display reads to .0005" or 0.01mm
- Large positive keypad
- Relative scale
- Fine adjust
- Furnished with two (2) 3-volt batteries (CR2032) and carbide tip scriber
- Easy access battery cover

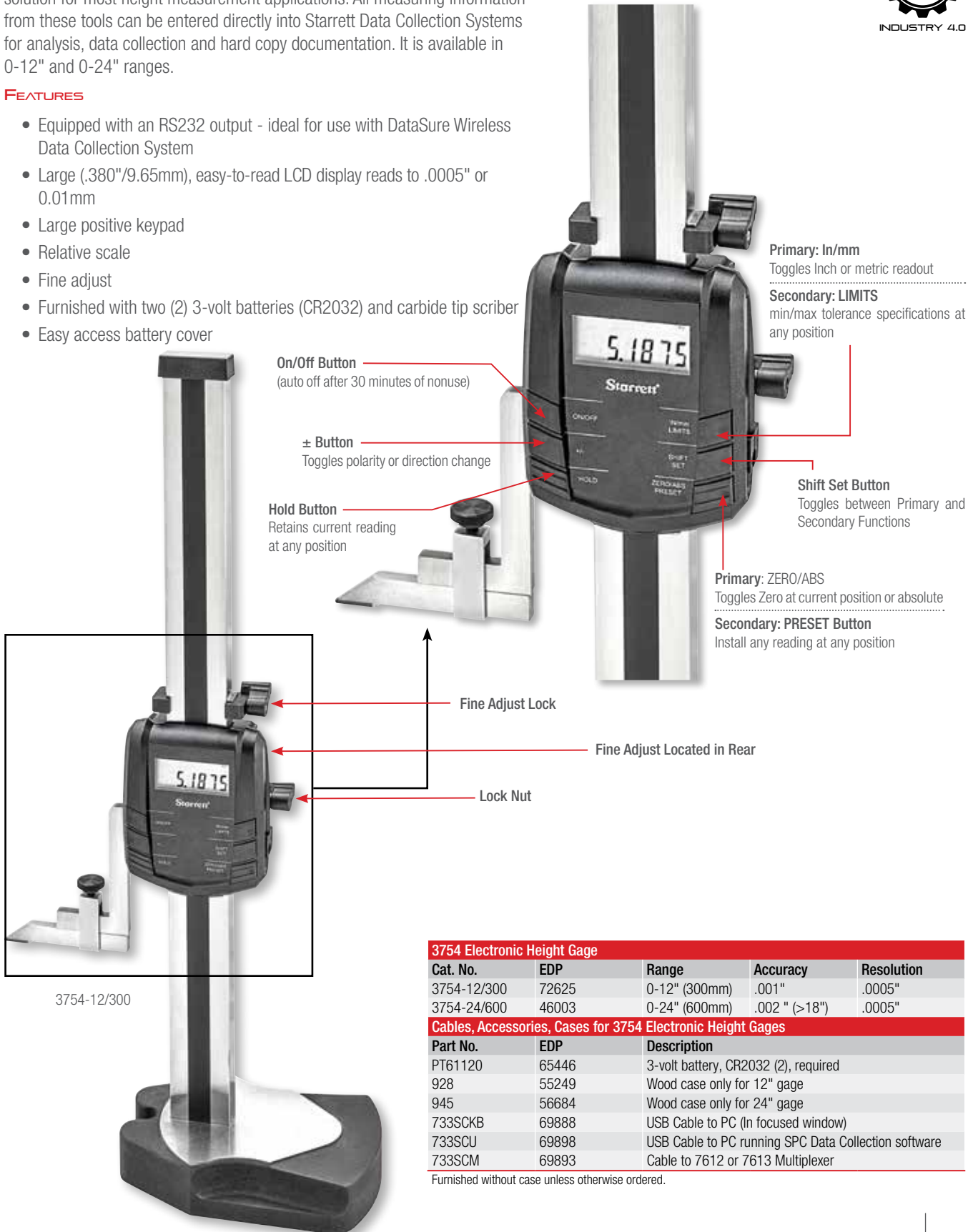

On/Off Button
(auto off after 30 minutes of nonuse)

± Button
Toggles polarity or direction change

Hold Button
Retains current reading at any position

Primary: In/mm
Toggles Inch or metric readout

Secondary: LIMITS
min/max tolerance specifications at any position

Shift Set Button
Toggles between Primary and Secondary Functions

Primary: ZERO/ABS
Toggles Zero at current position or absolute

Secondary: PRESET Button
Install any reading at any position

Fine Adjust Lock

Fine Adjust Located in Rear

Lock Nut



3754-12/300

3754 Electronic Height Gage

Cat. No.	EDP	Range	Accuracy	Resolution
3754-12/300	72625	0-12" (300mm)	.001"	.0005"
3754-24/600	46003	0-24" (600mm)	.002" (>18")	.0005"

Cables, Accessories, Cases for 3754 Electronic Height Gages

Part No.	EDP	Description
PT61120	65446	3-volt battery, CR2032 (2), required
928	55249	Wood case only for 12" gage
945	56684	Wood case only for 24" gage
733SCKB	69888	USB Cable to PC (In focused window)
733SCU	69898	USB Cable to PC running SPC Data Collection software
733SCM	69893	Cable to 7612 or 7613 Multiplexer

Furnished without case unless otherwise ordered.



DIGI-CHEK™ HEIGHT GAGES

258, 258M DIGI-CHEK™ HEIGHT GAGES

.100"-24.100"/2-602MM

These gages combine the accuracy of Starrett-Webber Gage Blocks with a precision micrometer head and digital readout.

258 DIGI-CHEK Height Gages (.100"-24.100" Range)						
Cat. No.	EDP	Range	Graduation		Micrometer Head	Gage Accuracy
			Scales	Digital Readout		
DHG12-E258	93005	.100"-12.100"	Inches	.001"	.0001"	±.0002"
DHG18-E258	93006	.100"-18.100"		.001"	.0001"	±.0002"
DHG24-E258	93357	.100"-24.100"		.001"	.0001"	±.0002"
258M DIGI-CHEK Height Gages (2-602mm Range)						
Cat. No.	EDP	Range	Graduation		Micrometer Head	Gage Accuracy
			Scales	Digital Readout		
DHG300-E258	93007	2mm-302mm	Millimeters	0.01mm	0.002mm	±0.005mm
DHG450-E258	93008	2mm-452mm		0.01mm	0.002mm	±0.005mm
DHG600-E258	93358	2mm-602mm		0.01mm	0.002mm	±0.005mm

Finished wood case for 12" (300mm) and 18" (450mm) also available, at additional cost. These finished wood cases are NOT suitable for shipping. Use suggested shipping materials. Certificate of Calibration available at additional cost. Questions and repair regarding Digi-Chek gages should be referred to the Starrett-Webber Division, Tel.: 440-835-0001. The accuracy of the surface that supports the gage must be taken into account when determining the accuracy of any measurements.

DHG12-258 with digital display



READABILITY FEATURES

- Satin chrome scales mounted beside the gage block column for quick reference to the nearest 1" or 25mm reading
- Digital readout reads in .001" or 0.01mm and has a range of 1" or 25mm
- Reads directly from the micrometer head to .0001" or 0.002mm. The micrometer head (our 469) has black figures on the satin chrome thimble. The graduations are staggered for easy counting.
- Both the micrometer head and digital readout are mounted on top of the gage, directly in line with the operator's vision

EASE-OF-HANDLING FEATURES

- The micrometer head has a speeder knob for rapid positioning
- Both over and under heights can be checked directly from the gage blocks in a single setting. Because reference surfaces are provided on the top and bottom of each block, adjacent blocks are in the exact same plane. This eliminates the need to add or subtract block thickness.
- Readings can also be taken from either left, center, or right of the gage block column
- Parts can be checked from .100" or 2mm in height
- The gage block column design permits wringing a 1" block between two blocks in the column. This is convenient for setting and checking other gages such as inside micrometers, end measuring rods, dial bore gages, etc.

ACCURACY AND LONG-LIFE FEATURES

- Gage is housed in a heavily flanged frame for stability and the base has three-point hardened, ground, and lapped bearing pads, making it virtually tip-proof. Gage blocks are assembled in a free-standing system that allows the blocks to conform to temperature variations independently of the frame, thereby reading the same as the workpiece.
- The highly accurate micrometer spindle is one piece, with hardened and stabilized measuring threads
- A 10" riser block is available for increased height capacity

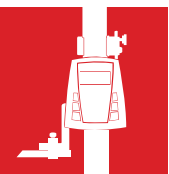

ELECTRONIC HEIGHT GAGES

3751 ELECTRONIC HEIGHT GAGE (WITHOUT OUTPUT)

0-6"/0-150MM

This height gage is light, portable and easy to use for vertical measurements within its range.

3751 Electronic Height Gage (0-6"/150mm Range)		
Cat. No.	EDP	Description
3751AZ-6/150	12221	Height Gage, in Case
Accessories and Cables for 3751 Electronic Height Gage		
Part No.	EDP	Description
PT99492	65650	One 3-Volt Batterie, CR2032
PT08680A	51383	Depth Attachment
947	56756	Wood Case Only



READABILITY FEATURES

- Large, easy-to-read .32" tall characters, high contrast LCD digital readout

ACCURACY AND LONG LIFE DESIGN FEATURES

- Hardened, stainless steel bar for long life
- Depth attachment PT08680A available for measuring depth of holes, slots, and recesses
- Fine adjustment thumb roll for precision measurements
- Rounded nose scriber cuts clean, sharp lines with smoothness and less pressure
- Lock to hold the slide in position
- Hardened, ground, and lapped base with finger grooves provides ease of movement
- Easy access to single long-life battery, 3-volt CR2032
- Vertical bar is back from the edge of the nose for better stability
- Scribe can reference zero from the bottom of the base to get the full 6" (150mm) usable range
- Linear Accuracy: $\pm 0.0015"$ ($\pm 0.02\text{mm}$)
- Resolution: $.0005"$ (0.01mm)

ACTION FEATURES WITH THREE CONTROL BUTTONS

- Inch-millimeter conversion
- Zero at any position
- Manual ON/OFF plus a built in auto OFF after 5 minutes of nonuse



DEPTH GAGES

5004 ELECTRONIC DEPTH GAGES (WITH OUTPUT)

0-24"/0-600MM

- Ideal for large part measurement up to 24" (600mm)
- Three movable bridge attachments provide additional large part measurement capacity

5004 Electronic Depth Gages

Cat. No.	EDP	Range/Size
5004BZ-12/300	14583	0-12" (0-300mm)
5004BZ-16/400	14584	0-16" (0-400mm)
5004BZ-20/500	14585	0-20" (0-500mm)
5004BZ-24/600	14586	0-24" (0-600mm)
5004BZ-32/800	14587	0-32" (0-800mm)

Accessories for 5004 Depth Gages

Part No.	EDP	Range/Size	Description
PT06133	12825	16" (400mm)	Movable bridge attachment for use with 5004 Depth Gages
PT06134	12826	20" (500mm)	Movable bridge attachment for use with 5004 Depth Gages
PT06135	12827	24" (600mm)	Movable bridge attachment for use with 5004 Depth Gages
PT06136	12828	1.024" (26mm) overall length	Offset attachment for use with 5004 Depth Gages

Smart Cables for 5004 Depth Gages

Part No.	EDP	Description
798SCKB	69889	USB Cable to PC (In focused window)
798SCU	73321	Smart Cable USB for 798, 5004B
798SCM	69894	Connect to 7612, 7613 Gage Mux

FEATURES AND SPECIFICATIONS

- IP67 level of protection against coolant, water, dirt and dust
- Equipped with an RS232 output - ideal for use with DataSure Wireless Data Collection System
- Hardened stainless steel construction
- Coolant resistant
- Mode and Set buttons control a wide range of functions: On/Off, Absolute/Relative display, Inch/Metric display, Preset and Hold
- RS232 data transmission port
- Furnished with one CR2032 lithium battery that will provide over a year of life with normal use
- Protective wooden case
- Resolution: 0.0005"/0.01mm
- Includes offset attachment PT06136

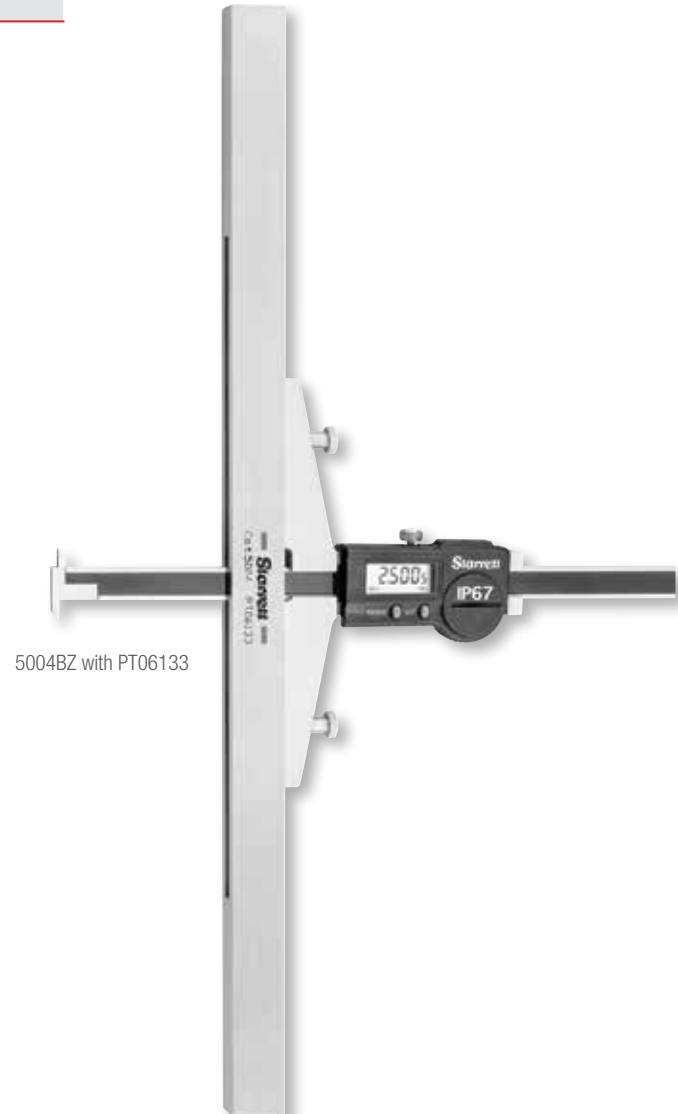
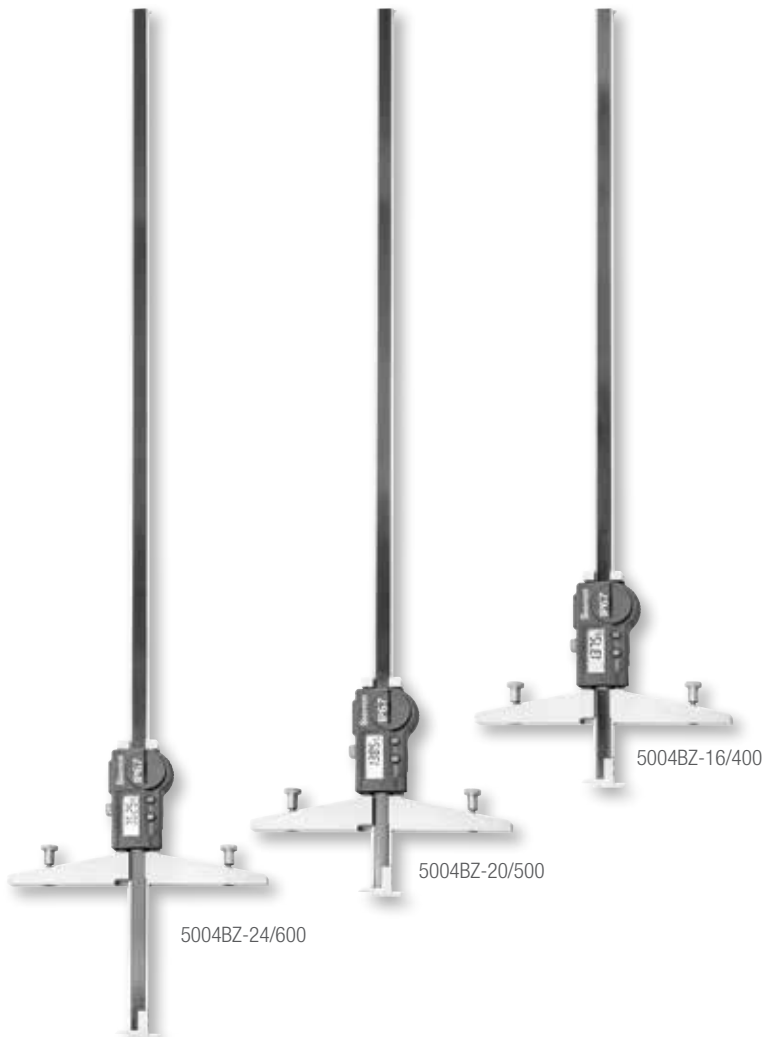

DEPTH GAGES

3753B ELECTRONIC DEPTH GAGES (WITH OUTPUT)

0-12"/0-300MM

The 3753B Electronic Depth Gage is a versatile, easy-to-use tool for measuring depth, slot width, small sections and other applications.

3753B Electronic Depth Gages		
Cat. No.	EDP	Description
3753B-6/150	12690	0-6"/150mm Range, Depth Gage in Case
3753B-8/200	12692	0-8"/200mm Range, Depth Gage in Case
3753B-12/300	12694	0-12"/300mm Range, Depth Gage in Case
Accessories for 3753B Electronic Depth Gages		
Part No.	EDP	Description
3648-180	12261	180mm Base Extension
3648-260	12262	260mm Base Extension
3648-320	12263	320mm Base Extension
PT63388	72517	Computer Interface Cable to PC (USB)
PT99492	65650	Two 3-Volt Batteries, CR2032
798SCKB	69889	USB Cable to PC (In focused window)
798SCU	73321	Smart Cable USB for 798, 5004B
798SCM	69894	To 7612 or 7613

FEATURES AND SPECIFICATIONS

- IP67 level of protection against coolant, water, dirt and dust
- Equipped with an RS232 output - ideal for use with DataSure Wireless Data Collection System
- Hardened, stainless steel bar for long life
- Removable hook attachment for measurements from the edge of a work piece to the inside or outside edge of slots, grooves, etc.
- Lock to hold the slide in position
- Fine adjustment thumb roll for precision measurements
- Large, easy to read LCD, .310" character height
- Induction type linear encoder system
- Patented non-contact RS232 data output
- CR2032 3-volt battery (>1 year batter life under normal use)
- Inch/mm conversion
- Zero at any position
- Auto OFF after 30 minutes of nonuse without loss of position upon reactivation
- Linear Accuracy: $\pm .0015"$ (0.03mm)
- Resolution: $.0005"$ (0.010mm)



3753B-6/150

3753B-12/300



DEPTH GAGES

3753A ELECTRONIC DEPTH GAGES (NON OUTPUT)

0-12"/0-300MM

The 3753 is light and easy to use for depth measurements within its range.

READABILITY FEATURES

- Clear, easily-read numbers, properly sized for the tool

DESIGN FEATURES FOR ACCURACY AND LONG LIFE

- Linear accuracy: $\pm .0015"$ ($\pm 0.03\text{mm}$)
- Resolution: $.0005"$ (0.01mm)
- Exclusive Starrett-designed microprocessor chip
- Hardened stainless steel body and slide for long life
- Fine adjustment thumb roll for precision measurements
- Lock to hold the slide in position
- Hardened base is 3-15/16" (99mm) long, but optional base extensions of 7" and 12" (175 and 300mm) are available. Spacing between holes is 2-3/4" (70mm).
- A hook attachment is furnished with the gage, making it possible to take readings from the edge of a workpiece to edges of slots, grooves, shoulders, and other I.D. length dimensioning. The removable hook has the screw permanently attached to prevent loss.
- One-year minimum battery life with furnished 3-volt battery, CR2032

ACTION FEATURES WITH THREE CONTROL BUTTONS

- Inch/millimeter conversion
- Zero at any position
- Manual ON/OFF plus a built in auto OFF after 15 minutes of nonuse

3753A Electronic Depth Gages

Cat. No.	EDP	Description
3753A-6/150	12258	0-6"/150mm Range, Depth Gauge in Case
3753A-8/200	12259	0-8"/200mm Range, Depth Gauge in Case
3753A-12/300	12260	0-12"/300mm Range, Depth Gauge in Case

Accessories for 3753A Electronic Depth Gages

Part No.	EDP	Description
3648-180	12261	180mm Base Extension
3648-260	12262	260mm Base Extension
3648-320	12263	320mm Base Extension
PT99492	65650	Two 3-Volt Batteries, CR2032



3753 shown with optional 3648-180 base extension attachment



ELECTRONIC INDICATORS

2900 ELECTRONIC INDICATORS (WITH OUTPUT)

RANGES FROM .5" (12MM) TO 2" (50MM)

AGD GROUP 2

The 2900 Electronic Indicators are available in a choice of configurations to meet a range of requirements. Innovative True Absolute Sensor Technology minimizes the chance of data loss for exceptional reliability. Built with IP67 protection and renowned Starrett quality, they maintain their reliability in hostile shop environments.



FEATURES

- Equipped with an RS232 output - ideal for use with DataSure Wireless Data Collection System. Intuitive design and layout – easy to learn and use
- Positive, tactile-feel button activation
- Long battery life
- CE compliant
- Data output to SPC on all models
- Choice of Basic, Standard and Advanced feature levels
- Fixed ratio measurement systems available
- Compatible with 25 Indicator backs
- Origin set, zero set
- All compatible with 2900 SCM, SCU and SCKB cables
- Counting direction switching (±)



INDICATORS AND GAGES

Inch/Metric -.375" Stem - #4-48 UNF Thread																
Cat. No.	EDP	Range		Resolution		Accuracy		Additional Features				Ftr. Lock	Max/Min/Runout Value Holding	True Abs. Sensor Tech.	Lug On Ctr. Bck.	CR2032 Btry. (2)
		in	mm	in	mm	in	mm	in/mm Cnv.	Limit Set	Value Preset	Reading Hold					
2900-1	09980	.5	12	.00005	0.001	±.00012	±0.003	x						x	x	x
2900-2	09981	.5	12	.0001	0.002	±.00012	±0.003	x						x		
2900-4	09983	.5	12	.0005/.0001/.00005	0.01/0.001	±.00012	±0.003	x	x	x	x	x	x	x	x	x
2900-6	09985	.5	12	.0005/.0001/.00005	0.01/0.001	±.00012	±0.003	x	x	x	x	x	x	x	x	x
2900-1-1	09960	1	25	.00005	0.001	±.00012	±0.003	x						x	x	x
2900-2-1	09962	1	25	.0001	0.01	±.00012	±0.003	x						x		
2900-3-1	09963	1	25	.0005	0.01	±.0001	±0.03	x							x	x
2900-4-1	09965	1	25	.0005/.0001/.00005	0.01/0.001	±.00012	±0.003	x	x	x	x	x	x	x	x	x
2900-5-1	09967	1	25	.0005	0.01	±0.001	±0.03	x	x	x					x	x
2900-6-1	09969	1	25	.0005/.0001/.00005	0.01/0.001	±.00012	±0.003	x	x	x	x	x	x	x	x	x
2900-1-2	72676	2	50	.00005	0.001	±.00012	±0.003	x						x	x	x
2900-4-2	72677	2	50	.0005/.0001/.00005	0.01/0.001	±.00012	±0.003	x	x	x	x	x	x	x	x	x
2900-6-2	72678	2	50	.0005/.0001/.00005	0.01/0.001	±.00012	±0.003	x	x	x	x	x	x	x	x	x

Inch/Metric - 8mm Stem - M2.5 x 0.45 Thread																
Cat. No.	EDP	Range		Resolution		Accuracy		Additional Features				Ftr. Lock	Max/Min/Runout Value Holding	True Abs. Sensor Tech.	Lug On Ctr. Bck.	CR2032 Btry. (2)
		in	mm	in	mm	in	mm	in/mm Cnv.	Limit Set	Value Preset	Reading Hold					
2900-1ME	09971	.5	12	.00005	0.001	±.00012	±0.003	x						x	x	x
2900-4ME	09976	.5	12	.0005/.0001/.00005	0.01/0.001	±.00012	±0.003	x	x	x	x	x	x	x	x	x
2900-6ME	09979	.5	12	.0005/.0001/.00005	0.01/0.001	±.00012	±0.003	x	x	x	x	x	x	x	x	x
2900-1ME-25	09972	1	25	.00005	0.001	±.00012	±0.003	x						x	x	x
2900-3ME-25	09975	1	25	.0005	0.01	±0.001	±0.03	x							x	x
2900-4ME-25	09977	1	25	.0005/.0001/.00005	0.01/0.001	±.00012	±0.003	x	x	x	x	x	x	x	x	x
2900-5ME-25	09978	1	25	.0005	0.01	±0.001	±0.03	x	x	x	x	x	x	x	x	x
2900-6ME-25	09991	1	25	.0005/.0001/.00005	0.01/0.001	±.00012	±0.003	x	x	x	x	x	x	x	x	x
2900-1ME-50	72679	2	50	.00005	0.001	±.00012	±0.003	x						x	x	x
2900-4ME-50	72681	2	50	.0005/.0001/.00005	0.01/0.001	±.00012	±0.003	x	x	x	x	x	x	x	x	x
2900-6ME-50	72683	2	50	.0005/.0001/.00005	0.01/0.001	±.00012	±0.003	x	x	x	x	x	x	x	x	x

Metric Only - 8mm Stem - M2.5 x 0.45 Thread																
Cat. No.	EDP	Range		Resolution		Accuracy		Additional Features				Ftr. Lock	Max/Min/Runout Value Holding	True Abs. Sensor Tech.	Lug On Ctr. Bck.	CR2032 Btry. (2)
		mm	mm	mm	mm	mm	mm	in/mm Cnv.	Limit Set	Value Preset	Reading Hold					
2900-1M	09986	12		0.001		±0.003								x	x	x
2900-4M	09988	12		0.01/0.001		±0.003		x	x	x	x	x	x	x	x	x
2900-6M	09990	12		0.01/0.001		±0.003		x	x	x	x	x	x	x	x	x
2900-1M-25	09961	25		0.001		±0.003								x	x	x
2900-3M-25	09964	25		0.01		±0.03									x	x
2900-4M-25	09966	25		0.01/0.001		±0.003		x	x	x	x	x	x	x	x	x
2900-5M-25	09968	25		0.01		±0.03		x	x	x					x	x
2900-6M-25	09970	25		0.01/0.001		±0.003		x	x	x	x	x	x	x	x	x
2900-1M-50	72680	50		0.001		±0.003								x	x	x
2900-4M-50	72682	50		0.01/0.001		±0.003		x	x	x	x	x	x	x	x	x
2900-6M-50	72684	50		0.01/0.001		±0.003		x	x	x	x	x	x	x	x	x

*Fixed ratios available with special order. (exception of 2900-5M-25)



ELECTRONIC INDICATORS

2700 BACKLIGHT ELECTRONIC INDICATORS (WITH OUTPUT)

The 2700 Backlight Electronic Indicators are offered in 1", 2" and 4" ranges. The deep backlight color indicates tolerances to read the indicator at far distances, in poor lighting, and with limited operator experience. A CD drive is required to use the software.

Cat. No.	EDP	Range	SPC Output	Accuracy	Resolution
2700-800	72758	1"	x	(±) 2. Res.	.0001"
2700-801	72759	1"	x	(±) 2. Res.	.000050"
2700-802	72760	2"	x	(±) 2. Res.	.0005"
2700-803	72761	2"	x	(±) 2. Res.	.0001"
2700-804	72762	4"	x	(±) 2. Res.	.0005"
2700-805	72763	4"	x	(±) 2. Res.	.0001"

Accessories, Power Source, Cables

Part No.	EDP	Description
PT60646	72592	Cable to SPC computer, not foot switch
2700SCKB	69891	USB Cable to PC (In focused window), all 2700 Series
2700SCU	23956	USB Cable, all 2700 Series
2700SCM	69896	SmartCable Gage MUX - all 2700 Series

Backs/Lever*

Part No.	EDP	Description
PT26406	65886	Flat back
PT26407	65887	Offset lug back
PT26411	65891	Adjustable lug back
PT26408	65888	Adjustable back
PT26409	65889	Post-type back
PT26410	65890	Screw bracket back
PT26848	66293	Adjustable mounting bracket back
PT26405	65885	Lifting lever

*Other backs, styles and accessories also available by request.

FEATURES

- Equipped with an RS232 output - ideal for use with DataSure Wireless Data Collection System
- Backlight relates a reading to tolerance values
- SPC Cables USB, MTI, RS232
- Inch/metric display
- Analog visual display
- Travel reverse
- Maximum reading hold
- Display/freeze hold
- Single gage simple data collection included
- Floating zero
- Minimum reading hold
- Abs./preset measuring mode
- T.I.R. with low and high storage recall
- Lock combination
- USB/AC power cable included
- Software included
- AC power source



ELECTRONIC INDICATORS

2700 WISDOM ELECTRONIC INDICATORS (WITH OUTPUT)

The 2700 Wisdom Electronic Indicator is one of the most versatile of the electronic indicators. All indicators feature a glass scale design with an unsurpassed accuracy of \pm two resolutions when measuring from a known standard. All have rugged, sealed enclosures as well.

FEATURES

- Equipped with an RS232 output - ideal for use with DataSure Wireless Data Collection System
- 8 resolutions and 4 measuring ranges available
- Plus or minus travel direction
- Zero the tool at any position of the spindle
- Rotating bezel
- Auto Off after 10 minutes of nonuse
- Three power sources - operate by battery, A/C adapter or through data port
- Output jack allows data transmission



Inch/Metric - .375" Stem - #4-48 UNF Thread							
Cat. No.	EDP	Range		Resolution		Accuracy	
		in	mm	in	mm	in	mm
F2720IQ	49508	.6	15	.001/.0005/.0001/.00005	0.02/0.01/0.002/0.001	\pm .0001	\pm 0.002
F2720AD	49500	.6	15	.001/.0005/.0001/.00005	0.02/0.01/0.002/0.001	\pm .0001	\pm 0.002
F2720-1AD	00043	.6	15	.001/.0005/.0001	0.02/0.01/0.002	\pm .0001	\pm 0.002
F2730IQ	49509	1	25	.001/.0005/.0001/.00005	0.02/0.01/0.002/0.001	\pm .0001	\pm 0.002
F2730-1IQ	49516	1	25	.001/.0005/.0001	0.02/0.01/0.002	\pm .0002	\pm 0.004
F2730AD	49501	1	25	.001/.0005/.0001/.00005	0.02/0.01/0.002/0.001	\pm .0001	\pm 0.002
F2730-1AD	00045	1	25	.001/.0005/.0001	0.02/0.01/0.002	\pm .0002	\pm 0.004
F2740IQ	49510	2	50	.001/.0005/.0001	0.02/0.01/0.002	\pm .0002	\pm 0.004
F2740AD	49502	2	50	.001/.0005/.0001	0.02/0.01/0.002	\pm .0002	\pm 0.004
F2750IQ	49511	4	100	.001/.0005/.0001	0.02/0.01/0.002	\pm .0002	\pm 0.004
F2750AD	49503	4	100	.001/.0005/.0001	0.02/0.01/0.002	\pm .0002	\pm 0.004
Inch/Metric - 8mm Stem - M2.5 x 0.45 Thread							
Cat. No.	EDP	Range		Resolution		Accuracy	
		in	mm	in	mm	in	mm
F2720IQM	49512	.6	15	.001/.0005/.0001/.00005	0.02/0.01/0.002/0.001	\pm .0001	\pm 0.002
F2720ADM	49504	.6	15	.001/.0005/.0001/.00005	0.02/0.01/0.002/0.001	\pm .0001	\pm 0.002
F2720-1ADM	09993	.6	15	.001/.0005/.0001	0.02/0.01/0.002	\pm .0002	\pm 0.004
F2730IQM	49513	1	25	.001/.0005/.0001/.00005	0.02/0.01/0.002/0.001	\pm .0001	\pm 0.002
F2730-1IQM	09992	1	25	.001/.0005/.0001	0.02/0.01/0.002	\pm .0002	\pm 0.004
F2730ADM	49505	1	25	.001/.0005/.0001/.00005	0.02/0.01/0.002/0.001	\pm .0001	\pm 0.002
F2730-1ADM	09994	1	25	.001/.0005/.0001	0.02/0.01/0.002	\pm .0002	\pm 0.004
F2740IQM	49514	2	50	.001/.0005/.0001	0.02/0.01/0.002	\pm .0002	\pm 0.004
F2740ADM	49506	2	50	.001/.0005/.0001	0.02/0.01/0.002	\pm .0002	\pm 0.004
F2750IQM	49515	4	100	.001/.0005/.0001	0.02/0.01/0.002	\pm .0002	\pm 0.004
F2750ADM	49507	4	100	.001/.0005/.0001	0.02/0.01/0.002	\pm .0002	\pm 0.004



ELECTRONIC INDICATORS

.250"/6MM AND .600"/15MM MODELS

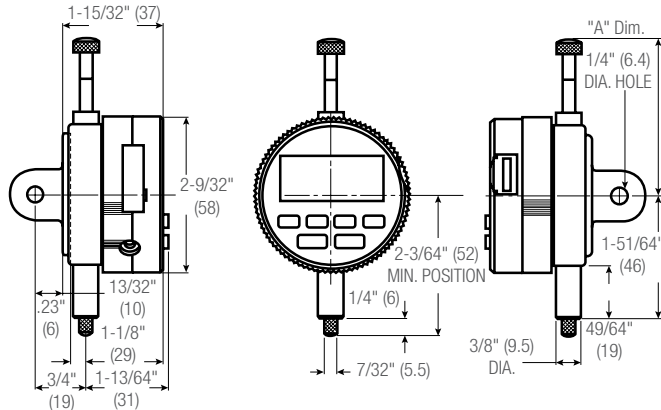

Travel		A Dimension	
in	mm	in	mm
.600	15	2-13/32	61
.250	6.4	2-1/16	52

1"/25MM MODELS

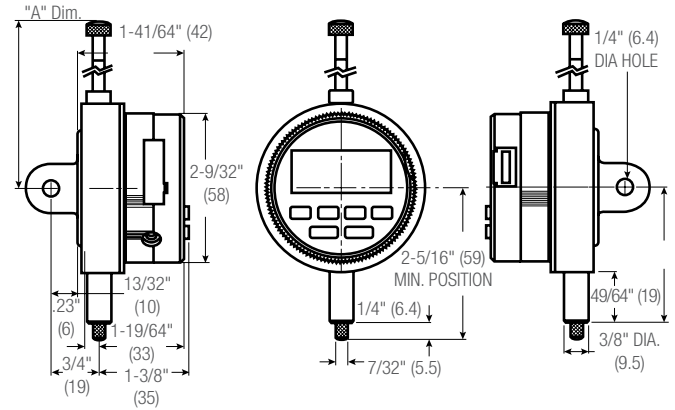

Travel		A Dimension	
in	mm	in	mm
1	25.4	2-7/8	73

2"/50 MM MODELS

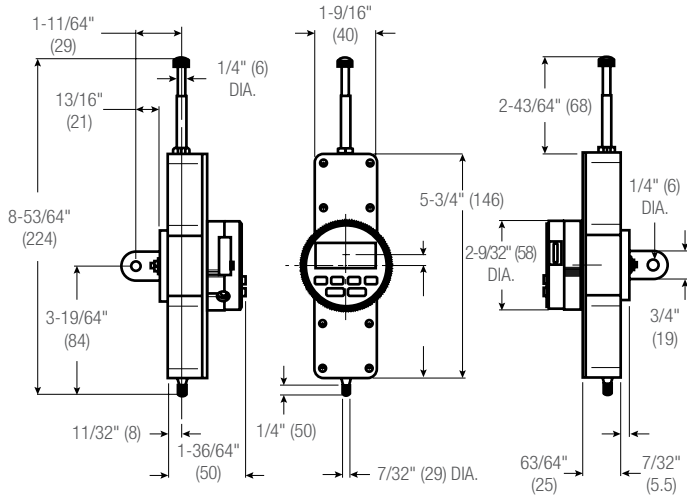

Accessories, Power Source, Cables

Part No.	EDP	Description
PT26413	65880	A/C Adapter, 110-Volt
PT26404	65884	Replacement Zinc Air Batteries, 4-Pack
PT61120	65446	Replacement Battery, 1-Pack (req. 2)
PT61489	65904	Cable to Module PT61490, to Connect to 772 Data Collectors and 761 Multiplexers
PT26415	65882	Cable for Wisdom Indicator to Wisdom Remote Display
PT26441	65893	USB Cable to RS232 (PC/Compatible)
2700SCM	69896	7612 Data Multiplexer Gage Interface

4"/100MM MODELS

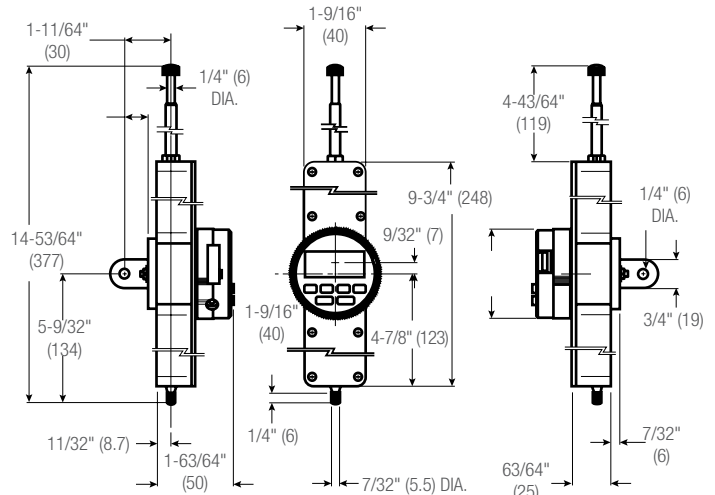

Backs/Lever*

Part No.	EDP	Description
PT26406	65886	Flat Back
PT26407	65887	Offset Lug Back
PT26411	65891	Adjustable Lug Back
PT26408	65888	Adjustable Back
PT26409	65889	Post-Type Back
PT26410	65890	Screw Bracket Back
PT26848	66293	Adjustable Mounting Bracket Back
PT26405	65885	Lifting Lever

* Other backs, styles and accessories also available by request. To order contact points individually, see previous pages.

Extension Cables

Part No.	EDP	Description
PT05679	68752	6' Extension Cable
2700SCKB	69891	USB cable to PC (In focused window)

Backs/Lever*

Part No.	EDP	Description
PT26406	65886	Flat Back
PT26407	65887	Offset Lug Back
PT26411	65891	Adjustable Lug Back
PT26408	65888	Adjustable Back
PT26409	65889	Post-Type Back
PT26410	65890	Screw Bracket Back
PT26848	66293	Adjustable Mounting Bracket Back
PT26405	65885	Lifting Lever

* Other backs, styles and accessories also available by request. To order contact points individually, see previous pages.
NOTE: Probe and display resolutions must be the same for accurate readings.



ELECTRONIC INDICATORS

2700 GROUP 1 Digital Indicators

(WITH OUTPUT)

AGD GROUP 1

FEATURES

- Equipped with an RS232 output - ideal for use with DataSure Wireless Data Collection System
- 270 degree Rotating Bezel - Allows viewing at different attitudes
- Smaller Diameter - A dimensional match to AGD Group one mechanical indicators (1.700"/43mm)
- Two Available Displays - Single LCD Numeric IQ model (largest of its class) with low battery warning and programmable ratios or Numeric/Analog AD model showing its two displays simultaneously
- .400" (10mm) travel
- Allows storage of 200 readings internally and viewed, stored readings can be downloaded with included software and USB style cable
- Long battery life, 3,000 hours under typical use also can be powered by plugging into your computer



F2715AD

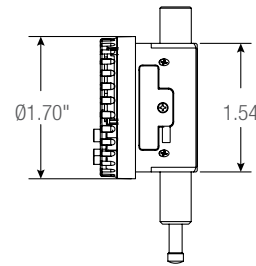
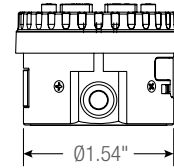
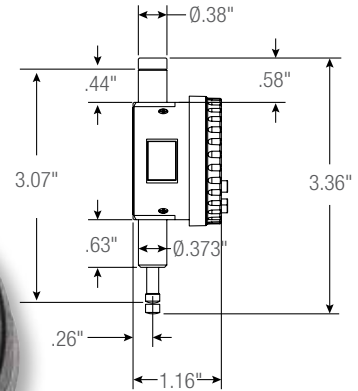

Inch/Metric - 8mm Stem - M2.5 x 0.45 Thread							
Cat. No.	EDP	Range		Resolution		Accuracy	
		in	mm	in	mm	in	mm
F2715IQ	72970	0.4	10	.001/.0005/.0001/.00005	0.02/0.01/0.002/0.001	±.0001	±0.002
F2715AD	72971	0.4	10	.001/.0005/.0001/.00005	0.02/0.01/0.002/0.001	±.0001	±0.002
F2714IQ	73273	0.4	10	.001/.0005/.0001	0.02/0.01/0.002	±.0001	±0.002
F2714AD	73274	0.4	10	.001/.0005/.0001	0.02/0.01/0.002	±.0001	±0.002

3900 ELECTRONIC INDICATORS

AGD GROUP 2

RANGES UP TO .500" AND 12.7MM

The 3900 Electronic Indicators have simple, powerful, easy-to-use functions, all at an attractive price. Versions are available for inch/metric and metric only.

FEATURES

- Large, easy-to-read LCD
- Power On/Off button
- Reverse travel (\pm control indicates direction)
- Zero setting at any position
- Long battery life
- 3/8" diameter stem for inch/mm model (8mm on metric-only model)
- 4-48 screw thread on inch/mm model (M2.5 X 0.45 thread on metric-only model)
- Lug-on-center back with additional flat back
- Dust cap
- Plastic storage case with clear cover



3900-5

Cat. No.	EDP	Range		Resolution		Accuracy	
		in	mm	in	mm	in	mm
3900-5	72538	.5	12.7	.0005	0.01	±.001	±0.03
3900M-5	72537		12.7		0.01		±0.03

Accessory		
Part No.	EDP	Description
PT61918	67169	SR44 battery



SPECIAL FUNCTION INDICATORS

765A ELECTRONIC SNAP GAGE

0-1/2"/0-12.7MM

High quality, economical gage that is ideal for inspectors, purchasing agents, sales people and others who need to quickly measure materials up to 1/2" or 12.7mm thick.

- Balanced, compact design
- Simple, logical control buttons
- Easy-to-read LCD
- Single, long-life battery with easy access
- Light-weight aluminum frame
- Inch/millimeter conversion
- Zero at any position
- Manual ON/OFF, AUTO OFF
- Furnished in fitted plastic case



765A

765A* Electronic Snap Gage

Cat. No.	EDP	Range		Linear Accuracy		Resolution	
		in	mm	in	mm	in	mm
765A	67659	0-1/2	0-12.7	±.0010	±0.02	.0005	0.01

Accessories

Part No.	EDP	Description
PT99492	65650	Two 3-Volt Batteries, CR2032

* No output available on the 765A.



ELECTRONIC BORE GAGES

781 AccuBore® ELECTRONIC BORE GAGES (WITH OUTPUT)

.080"-8"/2-200MM

AccuBore is a high-quality, trigger-activated, two-point and three-point contact bore gaging system with extended range. Its convenient single-hand operation provides speed and control. Simply squeeze the trigger, insert the gage into the bore and release the trigger for an instant reading from the large, easy-to-read digital display.

What makes AccuBore superior to other gages are features like the mechanically-driven parallel anvils which extend simultaneously, establishing a more true alignment to the axis of the bore. This provides consistent pressure, resulting in more accurate readings than models with spring-driven contacts which are subject to pressure variations.

Speed and convenience are further enhanced by the repositionable AccuBore® indicator, which may be swiveled and rotated for left, right hand or even vertical viewing. The gage also features a set of "Go/No-Go" lights in the readout display that quickly indicates whether a bore measurement is within a preset tolerance.

FEATURES

- Equipped with an RS232 output - ideal for use with DataSure Wireless Data Collection System
- Wireless capability
- Single-hand operation with right- and left-hand viewing flexibility
- Large, easy-to-read display
- Enhanced wear life with carbide-faced contacts – available from 1/2" to 8"
- Convenient "Go/No-Go" tolerance indicator lights
- True alignment with mechanically-driven parallel anvils
- Resolution .00005" (0.001mm)
- Accuracy of up to .00015" (0.004mm)
- Push button inch/metric conversion
- Preset and preset recall
- Hold, max/min and zeroing capabilities
- Blind bore measurement is standard for .50" (12.7mm) and above
- Specialized heads available for thread, groove and other non-standard measurements on request



INDUSTRY 4.0

BORE GAGE MEASURING TIPS

Whether to use a two-point or three-point contact measuring tool is usually a matter of preference, but there are some differences.

A two-point contact rod-type inside micrometer is usually lighter, easier to handle, and more versatile over long ranges from approximately 6-107" (150-2700mm).

Any two-point contact micrometer, regardless of range, can probe a hole better to find the geometry of that hole than a three-point contact.

Most three-point contact tools have setting rings to ensure accuracy. If you desire very close tolerance work with two-point contact inside micrometers, it is recommended that they be set to a ring gage or to an outside micrometer.

A three-point contact micrometer has an advantage in that it can be seated in position more quickly than a two-point contact tool.

Usually these tools can also be read to a finer accuracy. The three-point tool will tell the maximum true diameter that can enter the hole a little faster than a two-point contact tool.

Micrometer heads used in these tools are accurate to $\pm .0001$ " or 0.002mm, but overall accuracy on tools that add rods is dependent on good practice and technique.

To ensure accuracy, these practices should be followed:

- Always make sure that there are no specks of dirt between the clamping surfaces of the rods and micrometer heads
- Tighten all rods uniformly, not too tightly, not too loosely, but a fairly firm assembly
- Assembling long sections should be done vertically or, with support, horizontally
- Because temperature can affect long rods used in these tools, they should be assembled in the same environment in which they will be used



781BXTZ-138





INDUSTRY 4.0

Sets include gage, contacts, setting rings, instructions, certificate of calibration and a 3v lithium battery in a protective carrying case

781BXT AccuBore Electronic Bore Gages with Output – 2-Point Contact (.080-.250" (2-6mm) Range)

Cat. No.	EDP	Range		Accuracy		Approx Meas. Depth		Ring Diameter	
		in	mm	in	mm	in	mm	in	mm
781BXTZ-100	73017	.080-.100	2-2.5	.00015	.004	3/8	9	.100	2.54
781BXTZ-120	73016	.100-.120	2.5-3	.00015	.004	1/2	12	.160	4.06
781BXTZ-160	73014	.120-.160	3-4	.00015	.004	3/4	18	.200	5.08
781BXTZ-200	73012	.160-.200	4-5	.00015	.004				
781BXTZ-250	73011	.200-.250	5-6	.00015	.004				

781BXT AccuBore® Electronic Bore Gages with Output – 3-Point Contact (1/4-8" (6-200mm) Range) – Fixed Anvils

Cat. No.	EDP	Range		Accuracy		Approx Meas. Depth		Ring Diameter	
		in	mm	in	mm	in	mm	in	mm
781BXTZ-312	73009	1/4-5/16	6-8	.00015	.004	2-1/4	58	.3125	7.94
781BXTZ-375	73007	5/16-3/8	8-10	.00015	.004	2-1/4	58	.500	12.7
781BXTZ-500	73004	3/8-1/2	10-12.5	.00015	.004	2-3/8	62	.500	12.7
781BXTZ-625	73002	1/2-5/8	12.5-16	.00015	.004	2-3/8	62	.750	19.05
781BXTZ-750	73000	5/8-3/4	16-20	.00015	.004	2-5/8	66	.750	19.05
781BXTZ-1	73018	3/4-1	20-25	.00015	.004	3-1/16	80	1.375	34.93
781BXTZ-138	73015	1-1-3/8	25-35	.00015	.004	3-1/16	80	2.625	65.68
781BXTZ-2	73013	1-3/8-2	35-50	.00015	.004	3-3/8	85	3.250	82.55
781BXTZ-258	73010	2-2-5/8	50-65	.0002	.005				
781BXTZ-314	73008	2-5/8-3-1/4	65-80	.0002	.005				
781BXTZ-4	73006	3-1/4-4	80-100	.0002	.005				
781BXTZ-5	73005	4-5	100-125	.00025	.006				
781BXTZ-6	73003	5-6	125-150	.0003	.007				
781BXTZ-7	73001	6-7	150-175						
781BXTZ-8	72999	7-8	175-200						

Pistol Grip Gage Only with Indicator*

Cat. No.	EDP	Range	
		in	mm
781BXTP-250	73021	.080-.250	2-6
781BXTP-750	73019	1/4-3/4	6-20
781BXTP-4	73020	3/4-4	20-100
781BXTP-12**	73022	4-8	100-200

Larger sizes available on special order.
 Gages are also available with dial indicators on special order.
 * Does not include heads, rings, etc.
 ** Heads above 8" available on special order.

Output jack enables collection of measurement data for SPC analysis



AccuBore XT's indicator can be rotated, allowing easy reading from either the right or left hand, or when accessing difficult to reach holes





ELECTRONIC BORE GAGES

781 AccuBore® ELECTRONIC BORE GAGES

See specifications on previous pages



BORE GAGES

781BXT AccuBore Electronic Bore Gage Set – 2-Point Contact (.080-.250" [2-6 mm] Range)

Cat. No.	EDP	Range		Number of Heads	Number of Rings
		in	mm		
S781BXTBZ	72998	.080-.250	2-6	5	3

781BXT AccuBore Electronic Bore Gage Sets – 3-Point Contact (.250-8" [6-200mm] Range – Fixed Anvils)

Cat. No.	EDP	Range		Number of Heads	Number of Rings
		in	mm		
S781BXTCZ	72997	.250-.375	6-10	2	1
S781BXTHZ	72992	.250-.750	6-20	5	3
S781BXTDZ	72996	.375-.750	10-20	3	2
S781BXT EZ	72995	.750-2.00	20-50	3	3
S781BXTJZ	72991	.750-4.00	20-100	6	4
S781BXTFZ	72994	2.00-4.00	50-100	3	2
S781BXTKZ	72990	4.00-6.00	100-150	2	1
S781BXTGZ	72993	4.00-8.00	100-200	4	4
S781BXTLZ	72989	6.00-8.00	150-200	2	1

Larger sizes available on special order.
Gages are also available with dial indicators on special order.

Accessories for 781BXT Electronic Internal Micrometers

Part No.	EDP	Description	Required for Initial Wireless Connection	
			1 Device	> 1 Devices
PT61055	72941	770B Output Cable to USB		
PT61057	72942	770B Output Cable to USB with Footswitch		
		Free VMUX Software - 1 channel; visit starrett.com	x	
PT02497	73447	Wireless 4.0 dongle to PC VMUX Lite (1channel); VMUX standard (8 channels)	x	x
PT60996	72945	VMUX Standard Software (up to 32 tools)		x
PT99492	65650	Two 3-Volt Batteries, CR2032		
PT02498	73024	Wireless 4.0 Indicator for 0.080-0.75" gages		
PT02499	73025	Wireless 4.0 Indicator for 0.75-12" gages		

Larger sizes available on special order.
Gages are also available with dial indicators on special order.



Extensions from 2-1/2" - 6" can be added to the 781XT, enabling internal measurements in deep hole bores

781BXTZ-500



S781BXTGZ



770BXTZ-250 Bore Gage with PT24272 Depth Stop Collar



ELECTRONIC BORE GAGES

770 ELECTRONIC BORE GAGES WITH IP67 PROTECTION (WITH OUTPUT)

.080-12"/2-300MM

770BXT Electronic Internal Micrometers provide IP67 level of protection against coolant, water, dirt and dust in hostile shop environments. In addition, they offer extended travel, reducing the need to exchange anvils.



770BXT-138

FEATURES

- Equipped with an RS232 output - ideal for use with DataSure Wireless Data Collection System
- Wide measurement range without changing anvils
- Resolution to .00005" (0.001 mm)
- Large high-contrast LCD digital readout is easy to read and reduces error
- Carbide measuring faces on sizes above 1/2" (12.5mm) diameter
- Extensions available for deep holes
- Includes instant inch/millimeter conversion and preset + and - functions
- Precision ratchet stop provides correct contact pressure for accurate readings
- Each micrometer bore gage with head comes with a wooden case, complete with setting ring, contacts, adjusting wrench, spare battery, and instructions



780XT Electronic Internal Micrometers, 2-Point Contact (.080-.250" (2-6mm) Range)

Cat. No.	EDP	Range		Accuracy		Approx. Meas. Depth		Ring Diameter	
		in	mm	in	mm	in	mm	in	mm
770BXTZ-100	72539	.080-.100	2-2.5	.00015	.004	3/8	9	.100"	2.54
770BXTZ-120	72540	.100-.120	2.5-3	.00015	.004	3/4	18	.160"	4.06
770BXTZ-160	72541	.120-.160	3-4	.00015	.004	15/32	12	.160"	4.06
770BXTZ-200	72542	.160-.200	4-5	.00015	.004	3/4	18	.160"	4.06
770BXTZ-250	72543	.200-.250	5-6	.00015	.004	3/4	18	.200"	5.08

780XT Electronic Internal Micrometers, 3-Point Contact (1/4-12" (6-300mm) Range), Fixed Anvils

Cat. No.	EDP	Range		Accuracy		Approx. Meas. Depth		Ring Diameter	
		in	mm	in	mm	in	mm	in	mm
770BXTZ-312	72544	1/4 - 5/16	6-8	.00015	.004	2-1/4	58	.3125	7.94
770BXTZ-375	72545	5/16 - 3/8	8-10	.00015	.004	2-1/4	58	.500	12.7
770BXTZ-500	72546	3/8 - 1/2	10-12.5	.00015	.004	2-3/8	62	.500	12.7
770BXTZ-625	72547	1/2 - 5/8	12.5-16	.00015	.004	2-3/8	62	.500	12.7
770BXTZ-750	72548	5/8 - 3/4	16-20	.00015	.004	2-5/8	66	.750	19.05
770BXTZ-1	72549	3/4 - 1	20-25	.00015	.004	2-5/8	66	.750	19.05
770BXTZ-138	72562	1 - 1-3/8	25-35	.00015	.004	3-1/16	80	1.375	34.93
770BXTZ-2	72563	1-3/8 - 2	35-50	.00015	.004	3-1/16	80	1.375	34.93
770BXTZ-258	72564	2 - 2-5/8	50-65	.00020	.005	3-1/16	80	2.625	65.68
770BXTZ-314	72566	2-5/8-3-1/4	65-80	.00020	.005	3-1/16	80	2.625	65.68
770BXTZ-4	72567	3-1/4 - 4	80-100	.00020	.005	4	100	3.250	82.55
770BXTZ-5	72568	4 - 5	100-125	.00025	.006	4-1/2	115	5.0	127.00
770BXTZ-6	72569	5 - 6	125-150	.00030	.007	4-1/2	115	7.0	177.80
770BXTZ-7	72570	6 - 7	150-175	.00030	.007	4-1/2	115	7.0	177.80
770BXTZ-8	72571	7 - 8	175-200	.00030	.007	4-5/8	118	9.0	228.60
770BXTZ-9	72572	8 - 9	200-225	.00030	.007	4-5/8	118	9.0	228.60
770BXTZ-10	72573	9 - 10	225-250	.00035	.009	4-5/8	118	11.0	279.40
770BXTZ-11	72574	10 - 11	250-275	.00035	.009	4-5/8	118	11.0	279.40
770BXTZ-12	72575	11 - 12	275-300	.00035	.009	4-5/8	118	11.0	279.40

See next page for sets.

Accessories for 770BXT Electronic Internal Micrometers

Part No.	EDP	Description	Required for Initial Wireless Connection	
			1 Device	> 1 Devices
PT61055	72941	770B Output Cable to USB		
PT61057	72942	770B Output Cable to USB with Footswitch		
		Free VMUX Software - 1 channel; visit starrett.com	x	
PT02497	73447	Wireless 4.0 dongle to PC Vmux Lite (1 channel); VMUX standard (8 channels)	x	x
PT60996	72945	VMUX Standard Software (up to 32 tools)		x
PT99492	65650	Two 3-Volt Batteries, CR2032		

See page 41 for sets.



ELECTRONIC BORE GAGES

770 ELECTRONIC BORE GAGES WITH IP67 PROTECTION (WITH OUTPUT)

See specifications on previous page



INDUSTRY 4.0

BORE GAGES

770BXT Electronic Internal Micrometer Sets, 2-Point Contact (.080-.250" [2-6mm] Range)

Cat. No.	EDP	Range		Number of Heads	Number of Rings
		in	mm		
S770BXTBZ	72576	.080-.250	2-6	5	3

770BXT Electronic Internal Micrometer Sets, 3-Point Contact (1/4-8" [6-200mm] Range), Fixed anvils

Cat. No.	EDP	Range		Number of Heads	Number of Rings
		in	mm		
S770BXTCZ	72577	1/4-3/8	6-10	2	1
S770BXTDZ	72578	3/8-3/4	10-20	3	2
S770BXTFZ	72579	3/4-2	20-50	3	2
S770BXTFZ	72580	2-4	50-100	3	2
S770BXTKZ	72581	4-6	100-150	2	1
S770BXTGZ	72582	4-8	100-200	4	2
S770BXTLZ	72583	6-8	150-200	2	1



S770BXTKZ



INREACH EXTENSIONS FOR 770B, 781B, 781 BORE GAGES

Extensions from 2-1/2 - 6" can be added to both the 770BXT and 78XT, enabling internal measurements in deep hole bores (Multiple extensions can also be used).

Internal Extensions						
Cat. No.	EDP	Ext. Size		Fits Models	Model Size	
		in	mm		in	mm
78/782F	65484	2.5	63	78XT, 770BXT, 781BXT-312-375	1/4-3/8	6-10
78/782G	65485	3	75	78XT, 770BXT, 781BXT-375-500	3/8-1/2	10-12.5
78/782H	65486	4	100	78XT, 770BXT, 781BXT-625-750	1/2-3/4	12.5-20
78/782J	65487	6	150	78XT, 770BXT, 781BXT-1 thru 2	3/4-2	20-50
78/782K	65488	6	150	78XT, 770BXT, 781BXT-2 thru 12	2-12	50-300

78-782J with 770BZ-2



BENCH HARDNESS TESTERS

3816B DIGITAL MOTORIZED BENCH HARDNESS TESTER

The 3816B Bench Hardness Tester offers easy, fully automated testing procedures and provides highly sensitive and accurate readings. The 3816B measures the full regular Rockwell Scales according to ASTM and SAE guidelines and accommodates all types of hard or soft metals and alloys, in numerous configurations. The tester is furnished with a diamond indenter, a 1/16" (1.6mm) ball indenter, three certified test blocks, four test tables – 5.87" (149mm) and 2.5" (63.5mm) flat anvils, 5/8" (15.9mm) spot anvil and a standard vee anvil. The gage and it's accessories also comes furnished with an accessory case.

3816 Hardness Testers

Cat. No.	EDP	Description
3816B	72972	Digital bench hardness tester

Accessories* for 3816 Digital Bench Hardness Tester

Cat. No.	EDP	Description
PT05245	67944	C Regular
PT05249	67948	1/16" (1.6mm) Ball Unit
PT05069	67897	RA Test Block (Rockwell A Scale 80)
PT05059	67888	RB Test Block (Rockwell B Scale 90)
PT05050	67879	RC Test Block (Rockwell C Scale 63)
PT05272	67969	Master Block Set, Rockwell C Scale

* For additional listings of test blocks and accessories, refer to the following pages in this section.

Specifications

Minor Load	10Kgf
Major Load	A: 60Kgf, B: 100Kgf, C: 150Kgf
Test Force Application	(Dead weight applies test force)
Test Force Control	Motorized
Results Display	Hi-def LCD digital readout
Throat Depth	6.50" (165mm)
Maximum Test Height	6.87" (175mm) **
Unit Height/Width/Depth	28 x 8.9 x 20.6" (711 x 226 x 523mm)
Unit Weight	187 lb (85kg)

** Requires bench alteration.

FEATURES

- Fully automated routines reduce operator involvement and speeds measurements
- Large touch screen display
- Programmable scale conversions, dwell times and sample counter
- Sample averaging is automatically calculated
- RS232C output
- Built in mini-printer for outputting readings
- USB output



INDUSTRY 4.0



3816B

PORTABLE HARDNESS TESTERS

3811A COMPACT HARDNESS TESTER



INDUSTRY 4.0

The 3811A is a state of the art, digital portable hardness tester, designed to test the hardness of large, hard metal parts.

The 3811A combines fast test speeds with ample memory and output. It performs tests that easily convert to most popular hardness scales such as Rockwell, Brinell, Vickers and Shore.

This compact hardness tester is loaded with useful functions usually found only on high priced models.



Includes base instrument, impact device D, calibrated test block, custom carry case, cleaning brush and operation manual

SPECIFICATIONS

- Accuracy: $\pm 0.5\%$ (referred to $L=800$)
- Repeatability accuracy: $\pm 4L$ units ($L=Leeb$)
- Measuring range: 200-960 HL
- For steel and cast steel, alloy tool steel, stainless steel, grey cast iron, spheroidal iron, cast aluminum, brass, bronze, wrought copper alloy
- Tool steel should be about 1" thick solid material or larger
- Operating temperature: 5-104 °F
- Dimensions: 5.96 x 2.938 x 1.270" (150 x 74 x 32mm)
- Weight: 8.6 oz. (245 grams)

FEATURES

- Leeb style tester designed for large, hard parts – load the impact body and place the impact device on your test piece
- Easy to use keypad operation – push the button to begin testing and obtain reading
- Auto identification of impact device
- Large LCD display with back light
- USB output
- Automatic conversions to Rockwell, Brinell, Vickers and Shore
- Automatic Mean value as well as Min and Max values
- Uses two AA alkaline batteries with low power indicator
- Memory capacity (100 groups)
- Optional impact devices and special support rings

3811A Portable Hardness Tester and Accessories

Cat. No.	EDP	Description
3811A	69881	Digital portable hardness tester with impact device D, calibrated test block, cleaning brush and carry case
HT-1800-110	20940	D+15 Impact Device
HT-1800-115	20941	DL Impact Device
HT-1800-125	20942	G Impact Device
HT-1800-130	20943	C Impact Device
HT-1800-120	20944	DC Impact Device
HT-1800-100	20945	Replacement D Impact Device
HT-1800-102	20946	Replacement Cable For All Impact Devices
HT-2500-105	20947	Replacement Impact Body
HT-1300-01	20948	Leeb D Test Block
HT-1100G-01	20949	Leeb G Test Block
S38R	67285	Support Ring Set

3811A Portable Hardness Tester with Integrated, Multi-functional Features

Style	Applications
D+15	Very narrow contact area with a set backed measurement coil. Measures hardness in grooves and recesses. Weight: 80g
DC	Extremely short impact device. Used for very confined spaces such as, holes, cylinders and internal measurements
C	Reduced impact energy probe (2 ft-lb) for measuring hardness of coatings, surface hardened, thin wall or impact sensitive components. Applies superficial indentation. Weight: 75g
G	Enlarged test tip and increased impact energy range (72 ft-lb – approx. 9 times the D). For lower quality finishes measuring in the Brinell range only (max. 650 HB). Designed for components like heavy castings, forgings. Weight: 250g
DL	Needle front section with 4mm diameter and 50mm length. Ideal for testing in confined spaces, the base of grooves and special components like gear wheels. Steel/Cast steel



Optional Remote Impact Devices



PORTABLE HARDNESS TESTERS

3810A Digital Portable Hardness Tester

The 3810A is a state-of-the-art digital instrument designed to test the hardness of large hard metal parts. Loaded with useful functions such as USB output and a built in printer, the 3810A is an ideal choice for fast, accurate hardness testing.

This versatile tester can perform tests that easily convert to the most popular hardness scales, including Rockwell, Brinell, Vickers and Shore.

The tester is easy to use: simply load the impact body, place the impact body on your test piece, then push the button to begin testing.

The 3810A is designed to test large hard parts that cannot be brought to a bench top machine. For example, tool steel should be close to 1" thick of solid material. The 3810A comes with a D impact device, calibration block, cleaning brush, manual and a carrying case.



INDUSTRY 4.0



3810A Portable Hardness Tester and Accessories

Cat. No.	EDP	Description
3810A	69871	Tester, D impact device, calibration block, cleaning brush, operation manual, custom carry case
HT-1800-110	20940	D+15 impact device. Very narrow contact area with set backed measurement coil. Measures hardness in grooves and recesses.
HT-1800-115	20941	DL impact device. Needle front section with 4mm diameter and 50mm length. For testing in confined spaces such as groove bases and special components such as gear wheels.
HT-1800-125	20942	G impact device. For components such as heavy castings and forgings. Enlarged test tip and increased impact energy range. For lower quality finishes measuring in the Brinell range only. G block required.
HT-1800-130	20943	C impact device. Reduced impact energy probe for measuring hardness of coatings and surface hardened, thin wall or impact-sensitive components. Applies superficial indentation.
HT-1800-120	20944	DC impact device. Very short for confined areas such as internal bores for various inside measurements.
HT-1800-100	20945	Replacement D impact device. Universal standard probe for a wide variety of applications.
HT-1800-102	20946	Replacement cable for all impact devices
HT-2500-105	20947	Replacement impact body D
HT-1300-01	20948	Leeb D test block
HT-1100G-01	20949	Leeb G test block
S38R	67285	Support ring set

SPECIFICATIONS

- Accuracy: $\pm 0.5\%$ (referred to $L=800$)
- Repeatability accuracy: $\pm 4L$ units ($L=Leeb$)
- Measuring range: 200-960 HL
- Materials: steel & cast steel, alloy tool steel, stainless steel, grey cast iron, spheroidal iron, cast aluminum, brass, bronze, wrought copper alloy
- Battery type: AA alkaline (4)
- Operating temperature: 5-104 °F
- Dimensions: 150 x 74 x 32mm
- Weight: 245 grams
- Includes 3810A tester, impact device D, calibration test block, cleaning brush, operation manual, custom carry case
- Available options include DC, D+15, DL, G, C impact devices, and special support rings

FEATURES

- Easy to use keypad operation
- Auto identification of impact device
- Large LCD display with back light
- USB output
- Automatic conversions to: Brinell, Rockwell B & C, Vickers and Shore
- Automatic mean value as well as Min & Max values
- Battery indicator
- Memory capacity (100 groups)



3810A

ROUGHNESS TESTERS

SURFACE ROUGHNESS TESTERS

SR160, SR300 AND SR400

Starrett surface roughness testing equipment is simple, accurate and of high quality. These units are tough, shock tested, and capable of withstanding the demands of a shop environment. Our surface roughness testers meet the increasing requirements across industries like safety, aerospace, automotive, precision bearings, and general manufacturing.



SR300/SR400

Surface Roughness Testers

Cat. No.	EDP	Description
SR160	72584	SR160 display with 5mm traverse unit, pick-up, diamond stylus, calibration standards, manual, carrying case, and international power adaptors.
SR300	21000	SR300 display with 17.5mm traverse unit, TalyProfile Lite software, pick-up, diamond stylus, calibration standard, manual and carrying case.
SR400	21001	SR400 display with 25mm traverse unit, TalyProfile Lite software, pick-up, diamond stylus, calibration standard, manual and carrying case.

Accessories - SR160

Cat. No.	EDP	Description
SR-112-3188	72667	Magnetic base
SR-112-4545	20220	USB charger
SR-112-5085	72666	Hard transport case
SR-112-2937	20968	Extra reference standard

Accessories - SR300 and SR400

Cat. No.	EDP	Description
SR-112-1534	20962	Reference standard
SR-112-2693	20964	Column and stand
SR-112-4545	20220	USB charger
SR-112-1517	20963	Support stand
SR-112-4570	20998	USB thermal printer
SR-112-4571	20999	Thermal paper
SR-112-1645	73033	Pair of 115mm (5.85") vee blocks
SR-112-2694	73036	Precision vise
SR-112-2695	73037	Ball joint vise

Software

Cat. No.	EDP	Description
SR-112-3680	20952	TalyProfile Gold - 2D analysis
SR-112-3681	20953	TalyProfile Silver - 2D analysis

Parameters

Cat. No.	EDP	Description
SR-112-4607	73038	AN-10 ISO 13565 automotive parameters for S116
SR-112-4608	73039	AN-11 statistics module for S116
SR-112-4609	73040	AN-12 ISO primary parameter set for S116

Pick-Ups

Cat. No.	EDP	Description
SR-112-1510	20961	7.875" (200mm) extension rod with lead
SR-112-1502	20956	Standard pick-up with 200µin (5µm) stylus
SR-112-1503	20957	Standard pick-up with 400µin (10µm) stylus
SR-115-P28495	21004	Small bore pick-up
SR-112-1505	20959	Right angle pick-up
SR-112-1506	20960	Recess pick-up
SR-112-1524UB	73028	Pick-up with chisel edge stylus
SR-112-1525	73029	Pick-up lift mechanism
SR-112-1531UB	73030	Pick-up with slide skid
SR-112-1599UB	73032	Pick-up with shoe
SR-112-2672UB	73034	Recess pick-up (2µm, 80µin, tip radius)
SR-112-2673UB	73035	Small bore pick-up (2µm, 80µin, tip radius); SR-112-4701 is preferred
SR-112-4707	73041	O-Ring pick-up
SR-112-4708	73042	25mm recess pick-up
SR-112-4709	73043	15mm recess pick-up
SR-112-4710	73044	O-Ring pick-up narrow
SR-112-4712	73046	O-Ring pick-up; deep 25mm
SR-112-4713	73047	O-Ring pick-up; deep 25mm with 2µm tip
SR-112-4714	73048	Flat skid pick-up
SR-112-4715	73049	Standard 112/1502 pick-up with 2.5µm tip
SR-112-4716	73050	Side skid pick-up 112/1531 with 2µm tip

All accessories listed above are available for order. Please contact your local Starrett representative for additional or special requirements.



SR160



ELECTRONIC DUROMETER

3805 ELECTRONIC DUROMETER

The 3805 Durometers are designed to test the hardness of rubbers and plastics. These sleek hand held hardness testers are crafted and engineered to perform at the highest level of accuracy. An ergonomic, lightweight design assists in taking precise and consistent hardness measurements.

Shore A scale is for testing the following materials:

Rubber: Soft vulcanized (i.e. tire), natural, nitrile Elastomeric materials (rubber & rubber like): GR-S, GR-1, neoprene, thiokol, flexible polyacrylic esters.

Other: Wax, felt, leather, etc. (materials that normally yield under fingernail pressure, such as the heel on your shoe).

Shore D scale is for testing the following materials:

Rubber: Hard

Plastics: Harder grades such as rigid thermoplastics, plexiglass, thermoploystrene, vinyl sheet, cellulose acetate, thermosetting, laminates (i.e. formica)

Other: Printing rolls, densified wood, etc. (materials that would not normally indent under fingernail pressure, such as a pocket comb or bowling ball).

FEATURES AND SPECIFICATIONS (3805B & 3805D)

- Measuring range: 0-100
- Deviation: <1%H
- Resolution: 0.5H
- Digital readout
- Auto Hold feature
- Accurate and repetitive deviation = 20~90HSA HSA<+/-1grade
- Uses 1-SR44 Button Cell Battery
- Storage case
- Energizer 357/303 (SR44W, SR44SW, EPX76) Silver Oxide multi drain watch battery

3805 Electronic Durometer

Cat. No.	EDP	Description
3805B	69882	3805B Shore A Scale Electronic Durometer in plastic case
SRB-3	68200	Shore A 3 Rubber Test Block Certified Set
3805D	02059	3805D Shore D Scale Electronic Durometer in plastic case



THICKNESS GAGES

3812 ULTRASONIC THICKNESS GAGE

The 3812 Ultrasonic Thickness Gage is a state-of-the-art digital ultrasonic thickness gage packed with features typically found only on high end models.

It measures the thickness of metallic and non-metallic materials such as steel, aluminum, titanium, plastics, ceramics, glass and any other good ultrasonic wave conductor that has parallel top and bottom surfaces.

This dynamic ultrasonic thickness gage accurately displays readings in either inch or millimeter units after a simple calibration to a known thickness or sound velocity.

3812 Ultrasonic Thickness Gage and Accessories

Cat. No.	EDP	Description
3812	67668	3812 Ultrasonic Thickness Gage, software, USB cable, couplant gel and carry case
UTG2800-400	72686	Replacement probe (straight) for 3812

FEATURES AND SPECIFICATIONS

- 4 digit LCD display with back light
- Upper/Lower limit preset alarm
- Measurement and scanning capabilities
- Adjustable sound velocity
- Extended memory
- 20 memory groups (100 files/group)
- Minimum display unit: 0.001" (0.01mm) selectable
- .040-12.0" measuring range (in steel with standard probe)
- 32-122 °F operating temperature
- 5MHz Frequency
- 4Hz update range
- USB output
- Power supply: Two 3V AA alkaline batteries with approximately 100 hours of life (with the backlight off)
- Power consumption: Working current is less than 3V
- Accuracy: \pm (0.5% thickness + .001")
- Dimensions: 5.90 x 2.91 x 1.30" (150 x 74 x 33mm)
- Weight: 8.6oz (245g)
- Includes tester and cables, software, USB cable, couplant gel and a rugged, form fit carrying case



THICKNESS GAGES

3813 COATING THICKNESS GAGE

The 3813 Coating Thickness Gage is a state-of-the-art coating thickness gage that utilizes the characteristics of both eddy current and magnetic induction to perform two types of thickness calculation.

The gage uses an integrated probe to automatically determine whether the substrate is ferrous or non-ferrous. Then, it either detects the thickness of non-magnetic coating on a magnetic substrate (ferrous) or the insulating coating on a non-magnetic conductive substrate (non-ferrous).

Testing performance is non-destructive and extremely accurate. The 3813 is ideal for a broad range of applications in manufacturing, engineering and commercial inspection.

3813 Thickness Gage

Cat. No.	EDP	Description
3813	69883	Coating Thickness Gage with steel and aluminum substrate samples, four calibrated thickness samples, batteries, manual and case

FEATURES AND SPECIFICATIONS

- Measuring range: 0-40mils (0-1000 μ m) max.
- Resolution: 0.1 μ m/0.1mils (0-99 μ m) or 1 μ m (over 100 μ m)
- Guaranteed tolerance (after one-point calibration): $\pm 1-3\%$ n or 2 μ m (whichever is greater)
- 4-digit display, .40" (10mm) height,
- Minimum measuring area: .20 x .20" (5 x 5mm)
- Minimum radius of curvature: Convex: .12" (3mm), Concave: 1.2" (30mm)
- Minimum substrate thickness: Ferrous: 20 mils (0.5mm), Non-ferrous: 2 mils (50 μ m)
- Zero calibration
- Foil calibration
- Maximum surface temperature of test object: 302 °F (maximum contact time 2 seconds)
- Power source: Four AA batteries
- Includes steel and aluminum substrate samples
- Includes four calibrated thickness samples
- Dimensions: 6.39 x 2.74 x 1.27" (161 x 69 x 32mm)
- Weight: 9oz. (260g)



STARRETT METROLOGY SYSTEMS

VISION SYSTEMS



Starrett vision systems combine high-resolution images with robust, precision mechanical metrology platforms to deliver superb accuracy and repeatable measurement results for a wide range of measurement applications.

FOR MORE INFORMATION VISIT:

starrett.com/vm



LASER MEASUREMENT SYSTEMS



Starrett laser-based, non-contact, dimensional measurement systems are employed on the factory floor for quality monitoring, process control and inspection. Our products have measurement accuracy and precision, system reliability, easy to use software. Training available!

FOR MORE INFORMATION VISIT:

starrett.com/lm



FORCE AND MATERIAL TESTING



Starrett Force Measurement and Material Test Systems deliver a reliable, accurate and easy-to-use solution for applications ranging from determining simple peak load measurement, through load/extension at limits, to more complex break determination.

FOR MORE INFORMATION VISIT:

starrett.com/fm



CONTACT INFORMATION GUIDE FOR NORTH AMERICA

COMPLETE, UP-TO-DATE CONTACT INFORMATION AVAILABLE AT STARRETT.COM

PRIMARY CONTACTS, SALES AND GENERAL INFORMATION

- **World Headquarters and Precision Tools:**
Athol, MA, (978) 249-3551
- **Metrology Equipment:**
Laguna Hills, CA, (949) 348-1213
- **Laser Measurement:**
Columbus, GA, (706) 323-5142
- **Granite Surface Plates and Accessories:**
Waite Park, MN, (320) 251-7171
- **Gage Blocks:**
Cleveland, OH, (440) 835-0001
- **Mexico:**
Saltillo, Coah, Mexico, (844) 432-4660

CALIBRATION

- **Precision Tools and Gages:**
Athol, MA, (978) 249-3551
- **Starrett Calibration Services:**
Duncan, SC, (864) 433-8407
- **Metrology Equipment:**
Laguna Hills, CA, (949) 348-1213
- **Granite Surface Plates and Accessories:**
Waite Park, MN, (320) 251-7171
- **Gage Blocks:**
Cleveland, OH, (440) 835-0001
- In Mexico, please call (844) 432-4660

REPAIR

- **Precision Tools and Gages:**
Athol, MA, (978) 249-3551
- **Metrology Equipment:**
Laguna Hills, CA, (949) 348-1213
- **Granite Surface Plates and Accessories:**
Waite Park, MN, (320) 251-7171
- **Gage Blocks:**
Cleveland, OH, (440) 835-0001
- In Mexico, please call (844) 432-46-60

CUSTOM SOLUTION DEVELOPMENT

- **Special Tools and Gages:**
Athol, MA, (978) 249-3551
- **Metrology System Development and Configuration:**
Laguna Hills, (949) 348-1213
- **Granite Based Custom Products:**
Waite Park, MN, (320) 251-7171
- In Mexico, please call (844) 432-4660

ADDITIONAL AND/OR UP-TO-DATE INFORMATION

- starrett.com
- Product Literature and Educational Materials:
Select the "Catalogs" button at starrett.com to order printed product information and to access literature PDFs for viewing and/or downloading
- In Mexico, please call (844) 432-4660



CORPORATE HEADQUARTERS AND MAIN FACTORY

THE L.S. STARRETT COMPANY

121 Crescent Street
Athol, MA 01331-1915 - U.S.A.

Tel: (978) 249-3551

Main Fax: (978) 249-8495

INTERNATIONAL LOCATIONS

BRAZIL

Starrett Indústria e Comércio Ltda.
Av. Laroy S. Starrett 1880 - Bairro Pinheirinho
Caixa Postal 171
13306-900 Itu, São Paulo - Brazil

Tel: 55 11 2118-8200

Fax: 55 11 2118-8003

SCOTLAND

The L.S. Starrett Company Ltd.
Jedburgh TD8 6LR - Scotland

Tel: 44 (0) 1835 863501

Fax: 44 (0) 1835 863018

CHINA

Starrett Tools (Suzhou) Company Limited
Suzhou Industrial Park
No. 339. Su Hong Zhong Road
Suzhou, Jiangsu Province
P.R. China 215021

Tel: 86 512 6741940

Fax: 86 512 67415697



HOW TO ORDER

For prompt delivery, technical support and assistance, contact your nearest industrial distributor.

PRODUCT DEMONSTRATION

All Starrett manufacturing and branch locations and many distributors can demonstrate an array of Starrett products at work. Contact your local distributor to learn more.



STARRETT PRODUCT LINES

Band Saw Blades

Force Measurement

Jobsite & Workshop Tools

Laser Measurement

Metrology Equipment

Precision Granite

Precision Ground Solutions

Precision Measuring Tools

PTA & Hand Tools

Service

Webber Gage Blocks



Follow us!



starrett.com

Starrett®

Phone: (978) 249-3551 | Fax: (978) 249-8495
121 Crescent Street-Athol, MA 01331-1915-USA

Bulletin 590 06/20 The L.S. Starrett Company 2020© Specifications subject to change.