

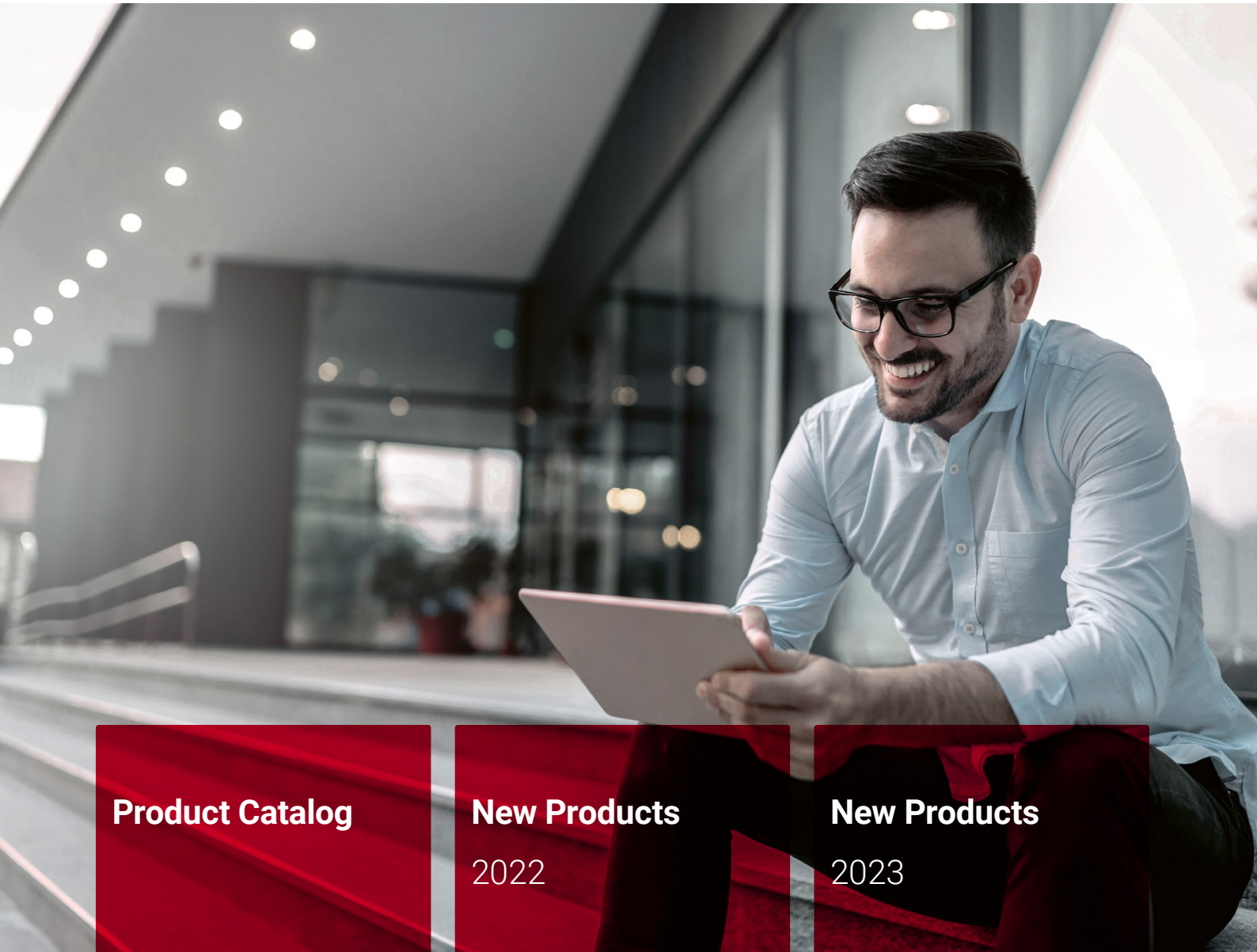

Our Online Catalog



Product Catalog

New Products

2022

New Products

2023

Page III

Page 669

Page 707



Main Catalog

Production metrology

61

Mahr | Main catalog

Your global partner
for **efficient**
quality assurance

Mahr's DNA

Maximum precision, modern technologies and a worldwide presence – that is what Mahr stands for. As a manufacturer of innovative production metrology, we have been supporting our customers for 161 years, in the measuring room and in production. This experience has made us experts in quality assurance for the automotive industry, mechanical engineering, aerospace, optics, and many other sectors. From manual calipers through to fully automated measuring stations: all of our products are built on the passion and expertise of our 1800 employees worldwide.

Increase productivity

As your global quality assurance partner, we offer products and solutions that combine proven precision with high efficiency. Short measuring times and easy operation speed up work processes. Through a clever combination of different measuring procedures, multiple tasks can be carried out by a single system – and in one setup. At the same time, innovative software tools and a wide choice of interfaces ensure that Mahr metrology is in tune with modern manufacturing requirements. Ensuring the productivity of your quality assurance is our aim.



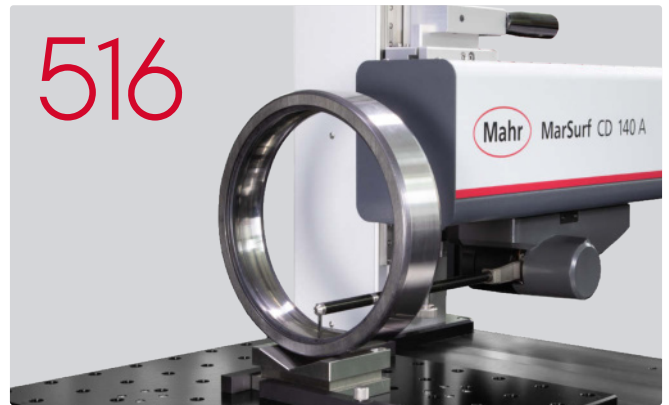

Contents

| | | |
|----------------------|--|---|
| Data transfer | MarConnect Wireless / Cable interfaces Software | 4 |
|----------------------|--|---|

| | | |
|--|---|-----|
| Handheld metrology | MarCal Calipers | 18 |
| | Micromar Micrometers | 60 |
| | MarTest Dial test indicator measuring devices 3D touch probe | 102 |
| | MarCator Dial indicators | 128 |
| | Millimess Dial comparators | 182 |
| | MarStand Measuring stands Measuring tables Radial runout gages | 268 |
| | Marameter Indicating measuring devices | 290 |
| | Multimar Universal measuring devices | 408 |
| MarGage Standards Dimensional standards | 440 | |

| | | |
|-------------------------|--|-----|
| Length metrology | Millimar [®] Electronic and pneumatic length metrology | 212 |
| | Digimar Height measuring devices | 472 |
| | Precimar Precision length metrology | 490 |

| | | |
|--|---|-----|
| Surface, contour and topography metrology | MarSurf Tactile surface metrology | 516 |
| | MarSurf 3D Optical surface metrology | 550 |

| | | |
|---|---|-----|
| Metrology for form, position, gears and dimensions | Mar4D Cylinder coordinate metrology | 594 |
| | MarForm Form metrology | 600 |
| | MarShaft Shaft metrology | 624 |
| | MarGear Gear metrology | 618 |
| | MarOpto Metrology for the optical industry | 580 |
| | MarVision Measuring microscopes | 570 |

| | | |
|-----------------------------|----------------------------------|-----|
| Customized solutions | Mahr Engineered Solutions | 638 |
|-----------------------------|----------------------------------|-----|

| | | |
|----------------|--|-----|
| Service | Mahr Service Product-related services | 646 |
|----------------|--|-----|

MarConnect | Measuring data processing

All new digital handheld measuring instruments come with the MarConnect flexible interface concept. Whether Integrated Wireless, external wireless modules, USB, Opto RS232, or Digimatic: Whatever interface standard you use, MarConnect always ensures an optimal connection.

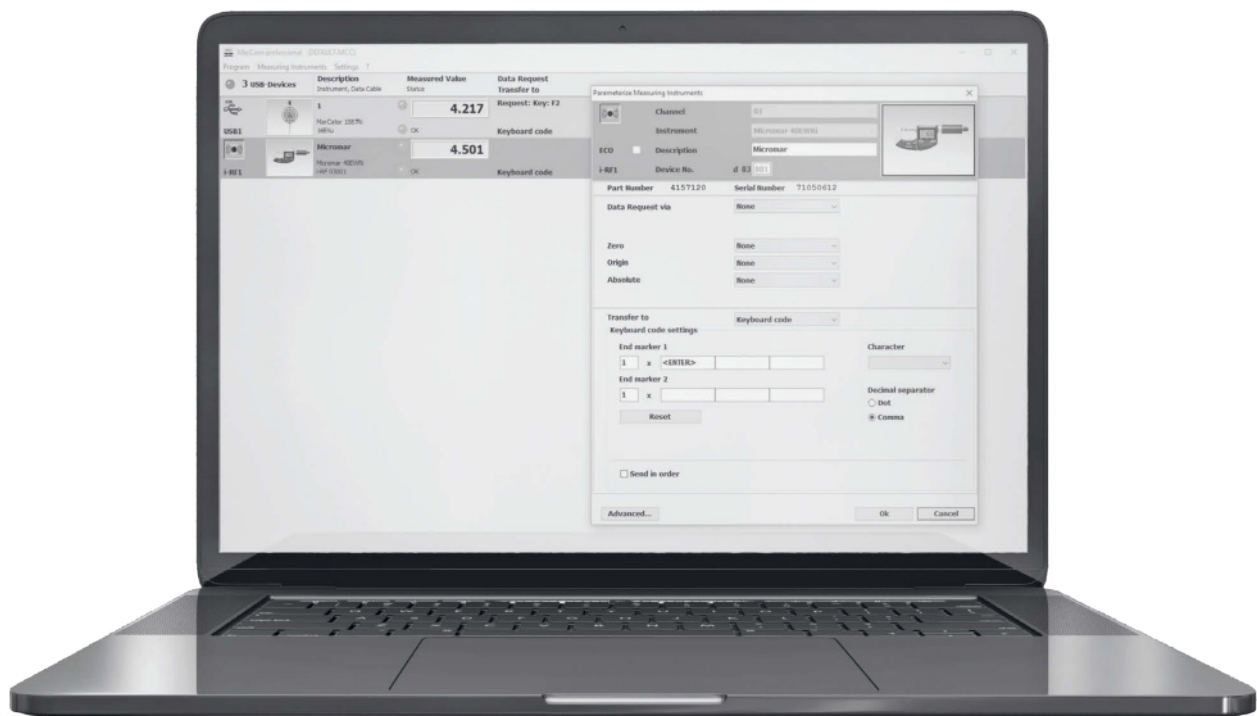

| | |
|--|-----------|
| MarConnect measuring data processing Wireless to the result | 6 |
| MarConnect MarCom Professional Software interface | 10 |
| MarConnect i-Stick Wireless receiver for measuring devices with Integrated Wireless | 12 |
| MarConnect e-Stick Wireless receiver | 14 |
| MarConnect data cable | |
| MarConnect Opto USB / Millimar USB / 817 USB / 16 EXu / DK-U1 / MC-I / 800 EWu / 2000 USB / 838 USB USB data cable | 15 |
| MarConnect 16 EXr / 16 Esv / 800 EWr / 2000 r RS232C data cable | 16 |
| MarConnect DK-D1 / 16 EWd / 2000 d / 838 di (A) Digimatic data cable | 17 |

Wireless to the result

Best performance in every step

Mahr's portfolio of wireless devices offers you maximum mobility for your measuring tasks. The wireless solution of Integrated Wireless measuring instruments means you can measure without impediment. Mahr measuring instruments are ideal tools for every manufacturing environment, reliably delivering the performance you have come to expect from state-of-the-art handheld measuring instruments.

Save costs

Use your wireless connection for the price of a cable. Purchasing a USB receiver stick (i-Stick) for your computer allows you to operate up to eight measuring devices simultaneously and saves you the additional cost of a connecting cable.

Unclutter

Keep your workplace clear of restrictive data cables.

ID transmission

Serial and order numbers are sent out by the measuring device and stored in the recorded measurement log.



Reliable

With integrated transmission, visual feedback is provided verifying data transmission. Error message signifies loss of data connector.



Maximum mobility

Measure autonomously and without limits. Thanks to their wireless, compact system, Mahr measuring instruments allow precise measuring – even in the machine or on difficult-to-reach workpieces.

6 meter range

8 measuring instruments simultaneously per i-Stick receiver

Integrated transmitter

Eliminate hazards such as cable breakage and wear.



Free software

Benefit from the MarCom Professional 5.3 interface software and transfer the measurement data individually and conveniently to your Windows applications or CAQ software.

81 device versions for every measuring task



It couldn't be easier!

Scan the QR code and see how Integrated Wireless handheld measuring instruments are used in practice.

Your interface for **even greater performance**

Two steps to the goal: combine your Integrated Wireless instruments with our multifunctional MarCom Professional software. This versatile interface tool combines data acquisition and data transfer with your data processing. How you process the collected data is entirely up to you – for maximum flexibility, choose from a range of output formats.

Enjoy maximum individuality at the workplace with a free choice of output medium and four output formats:

- Virtual interface box: CAQ/SPC software
- Intelligent Excel interface: Microsoft Excel
- Emulation keyboard: any Windows software
- Text file: flexible data processing

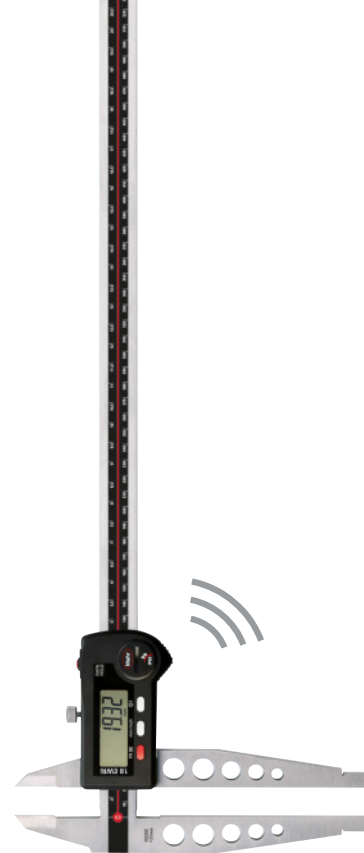

MarCal 18 EWRi workshop caliper with Integrated Wireless

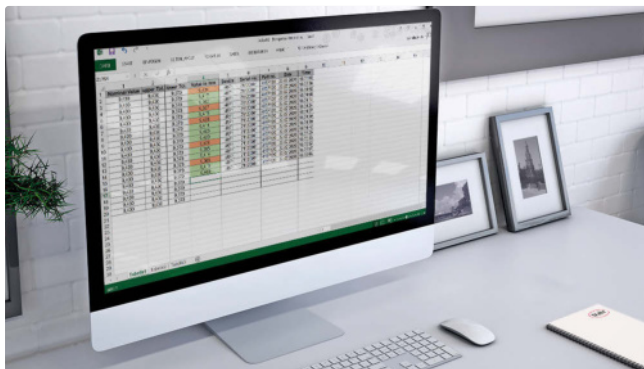

MarCom Professional is IATF ready and features a comprehensive range of functions for data transfer and data processing.

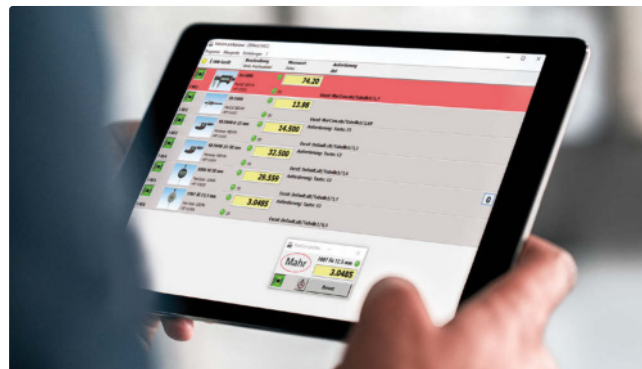



Micromar 40 EWRi micrometer with Integrated Wireless

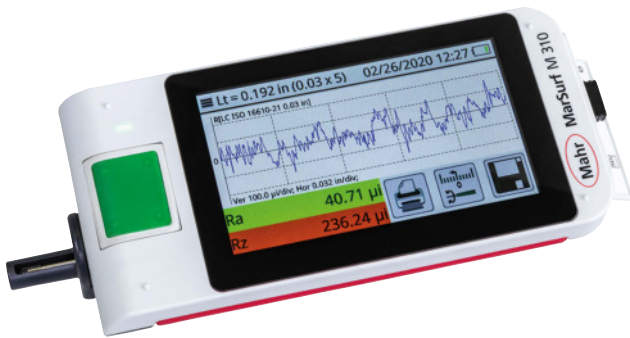

MarSurf M 310 roughness measuring instrument with Bluetooth® stick

Improved functions:

- Additional data: Additional values are transferred to supplementary columns (name, serial number, item number, date and time)
- Device parameters can now be preset: reference values (preset, tolerance limits, warning limits in %), as well as, function locks can be queried and changed on the instrument
- Improved Excel functionality:
 - Easily undo the last data transfer – right in the program with a simple click
 - Adapted column and row names: Z1S1 reference style for use with Excel as in practice

Powerful and user-friendly due to continual updates!

Perfectly coordinated: MarCom Professional is the ideal data transfer software for all your quality assurance and production needs then start new sentence It is perfectly equipped from the Integrated Wireless product line. A number of additional functions offer users maximum convenience when recording and transferring measurements.

3x

faster configuration

Save time: conveniently configure your measuring instruments via PC interface and eliminate the need for manually setting the instrument.

99 %

more reliable

Avoid operating errors: all information is automatically transferred and assigned thanks to the automatic identification of measurements and serial number transfers.

New features:

- IATF ready: transfers and displays the measuring equipment ID and item and serial number to clearly allocate the measuring equipment to the measurements
- Tab settings in up to 3 areas: settings, device parameters and goal
- Scalable measurement value display
- Manually sort the device overview using drag-and-drop



FEATURES

- Direct transfer of measuring values into MS Excel (version 97 or later), into SPC software via virtual interface box (MUX 50 format) (professional) or into a text file or via a keyboard code
- The measuring values for each connected measuring instrument can be copied into a separate column, table or folder in Excel
- USB hubs can also be connected as a measuring instrument interface
- Clear depiction of the selected measuring devices by means of icons
- Manual sorting of the device overview using drag-and-drop
- Scalable measurement value display
- Configure device parameters easily. Reference values (preset, tolerance limits, warning limits) as well as function locks can be queried and changed on the instrument
- Freely definable and configurable measurement cycles
- Flexible, user-friendly transfer of measuring values via the 'Data' button on the measuring device or data cable or via a PC keyboard, timer, foot switch connected to a USB interface or via wireless remote control
- Additional data: Transfers and displays the measuring equipment ID and item and serial number to clearly allocate the measuring equipment to the measurements
- Easily undo the last data transfer – right in the program with a simple click
- **Package contains:** driver, instruction manual
- **Software:** MarCom Professional free download: www.mahr.com/marcom (only for Mahr data cables and wireless systems with USB and RS-232 interface)

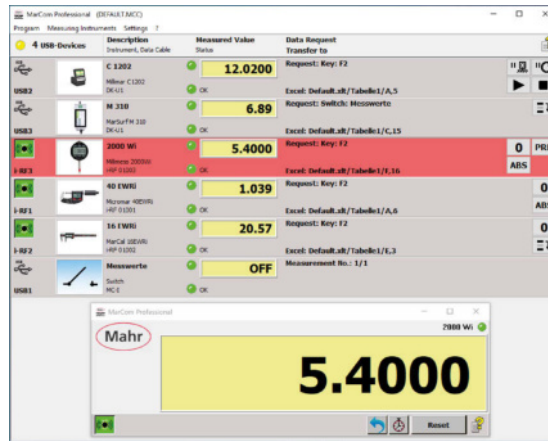

TECHNICAL DATA

| Type | MarCom Professional |
|---|---|
| Number of connectable wireless receivers for i-Stick | 4 |
| Number of connectable measuring instruments with Integrated Wireless | 32 |
| Number of connectable wireless receivers for e-Stick | 1 |
| Number of connectable transmission modules for e-Stick | 8 |
| Number of connectable wireless receivers FM 2 | 1 |
| Number of connectable transmission modules for wireless receiver FM 2 | 100 |
| Number of connectable measuring instruments with USB interface | 128 |
| Number of connectable USB foot switches | 128 |
| Number of connectable measuring instruments with RS232C interface | 2 |
| Number of virtual interface boxes (8 inputs) | 4 |
| Languages | German, English, French, Italian, Spanish, Dutch, Russian, Polish, Portugese, Czech, Chinese, Romanian, Hungarian, Japanese |

ACCESSORIES

| Order no. | Description | Type | For measuring instrument |
|-----------|---|---------|---|
| 4102220 | Receiver for instruments with Integrated Wireless | i-Stick | MarCal 16 EWri / 30 EWRi, MarCator 1086 Ri / 1086 WRi / 1087 Ri / 1087 BRi, Micromar 40 EWRi / 40 EWRi-L, Millimes 2000 W(i), 2001 W(i), Digimar 817 CLT |
| 4102230 | e-Stick Receiver | e-Stick | Transmission modules 16 EWe, 2000 e, RS232 e |
| 4102305 | Receiver | FM 2 | Transmission modules 16 EXf, 1082 f, 2000f, 817 f, RS232 f |
| 4102231 | USB Bluetooth adapter | 16 EWe | MarCal 16 ER, 16 EWR, 16 EWW, 18 EWR, 30 EWR, 30 EWN Digimar 814 SR Micromar 40 EWR (≤2017), 40 EWS, 40 EWW, 44 EWR, 46 EWR MarCator 1075 R, 1086 R, 1087 R, 1087 BR MarSurf PS1, PS10 |
| 4102306 | 16 EWe Transmitter for e-Stick | 16 EXf | MarCal 16 ER, 16 EWR, 16 EWW, 18 EWR, 30 EWR, 30 EWN Digimar 814 SR Micromar 40 EWR (≤2017), 40 EWS, 40 EWW, 44 EWR, 46 EWR MarCator 1075 R, 1086 R, 1087 R, 1087 BR |
| 4102357 | 16 EXf Transmitter for FM 2 | 16 EXu | MarCal 16 ER, 16 EWR, 18 EWR, 30 EWR, 30 EWN Digimar 814 SR Micromar 40 ER, 40 EWR (≤ 2017), 40 EWW, 40 EWS, 44 EWR, 46 EWR MarCator 1075 R, 1086 R, 1086 Ri, 1087 R, 1087 Ri, 1087 BR, 1087 BRi MarSurf PS1, PS10, M300, M300C |
| 3003856 | 16 EXu Data connection cable USB (2 m) | USB BT | MarSurf M 310 |

MarConnect MarCom Professional

Software interface

ACCESSORIES

| Order no. | Description | Type | For measuring instrument |
|-----------|--|----------------|--|
| 4102410 | Data connection cable RS232C (2 m) | 16 EXr | MarCal 16 ER, 16 EWR, 18 EWR, 30 EWR, 30 EWN Digimar 814 SR Micromar 40 ER, 40 EWR (≤ 2017), 40 EWW, 40 EWS, 44 EWR, 46 EWR MarCator 1075 R, 1086 R, 1086 Ri, 1087 R, 1087 Ri, 1087 BR, 1087 BRi MarSurf PS1, PS10, M300, M300C |
| 4102232 | 2000 e Transmitter for e-Stick | 2000 e | Digimar 816 CL MarCator 1088 / 1088W Millimess 2000, 2001, 2100, μ Maxum II Millimar C1200 |
| 4102309 | 2000 f Transmitter for FM 2 | 2000 f | Digimar 816 CL, Millimar C 1200 MarCator 1088 / 1088W Millimess 2000, 2001, 2100, μ Maxum II |
| 4346023 | 2000 USB data connection cable USB (2 m) | 2000 USB | Digimar 816 CL, Millimar C1200 MarCator 1088, 1088 W Millimess 2000, 2001, 2100, μ Maxum II |
| 4346020 | Data connection cable RS232C (2 m) | 2000 r | Digimar 816 CL, Millimar C1200 MarCator 1088, 1088 W Millimess 2000, 2001, 2100, μ Maxum II |
| 7024634 | Data connection cable RS232C (3 m) | | Digimar 817 CLM Millimar C1208, C1216, 1240, C1245, S1840, S1841, X1715, X1745, 832 |
| 4102233 | RS-232 e Transmitter for e-Stick | RS-232 e | Millimar C1208, C1216, C1245, S1840, Digimar 817 CLM |
| 4102331 | Millimar - USB Adapter cable RS-232-USB (0,2 m) | Millimar - USB | Millimar C1208, C1216, 1240, C1240, C1245, S1840, S1841, X1715, X1741, 832 (in conjunction with cable 7024634) |
| 4102310 | 817 f Transmitter for FM 2 | 817 f | Digimar 817 CLM |
| 4102333 | 817 USB Adapter cable RS232-USB (0,2 m) | 817 USB | Digimar 817 CLM (in conjunction with cable 7024634) |
| 4102311 | RS232 f Transmitter for FM 2 | RS232 f | Millimar C1208, C1216, C1245, S1840 |
| 4102307 | 1082 f Transmitter for FM 2 | 1082 f | Digimar M814 N/G Multimar 25 ES MarTool 106 ES |
| 4102510 | Data connection cable RS232C (2 m) | 16 ESv | Digimar 814 G, 814 N Multimar 25 ES MarTool 106 ES |
| 4102330 | Opto USB Adapter cable RS232-USB (0,2 m) | Opto USB | Digimar M814 (in conjunction with cable 4102510) Multimar 25 ES (in conjunction with cable 4102510) MarTool 106 ES (in conjunction with cable 4102510) |
| 4305121 | 800 EWu data connection cable USB (2 m) | 800 EWu | MarCal 31 EW MarTest 800 EW, 800 EWL |
| 4305122 | Data connection cable RS232C (2 m) | 800 EWr | MarCal 31 EW MarTest 800 EW, 800 EWL |
| 4102553 | USB-Hub 7-fold industrial model | USB-Hub | |
| 4102782 | MC-I adaption cable (for foot switch via MarCom): jack plug \varnothing 3.5 mm/USB (0,1 m) | MC-I | Foot switch 16 ESf |
| 4102058 | Foot switch to trigger data transmission | 16 ESf | |
| 4102221 | Wireless remote control for MarCom | MC-R | |
| 4102603 | Data cable USB bi-directional (2 m) | DK-U1 | Micromar 40 EWR (≥ 2018), Millimar C 1202, MarSurf M310, Millimess 2000 W(i), 2001 W(i), Digimar 817 CLT |
| 4102606 | Interface adapter with data cable Digimatic (2 m) | DK-D1 | Micromar 40 EWR (≥ 2018), Millimar C 1202, Millimess 2000 W(i), 2001 W(i) |





FEATURES

- Unlike conventional wireless solutions, which have a large external transmitter with separate battery, the transmitter in integrated wireless is fully integrated.
- The lack of external cables and modules allows for high mobility
- With Integrated Wireless, you can transfer your measured values to the PC using the i-Stick
 - As with a data cable, the measured values are accepted via the MarCom Software directly into MS Excel® or via a keyboard code into any Windows application
- Safe and reliable data transfer
 - Instruments display messages confirming data has been received
 - Confirms being in range of i-Stick
- Long battery life
 - Negates need for additional battery
- With Integrated Wireless, you can connect up to 8 measuring instruments per i-Stick receiver
 - Expensive interface boxes are no longer necessary
- **Package contains:** i-Stick wireless receiver, driver
- **Software:** MarCom Professional free download: www.mahr.com/marcom (only for Mahr data cables and wireless systems with USB and RS-232 interface)



TECHNICAL DATA

| | | |
|---|----------------|--|
| Order no. | 4102220 | |
| Number of channels | | 3 |
| Frequency band | MHz | 2400 |
| Radio range | | Up to 6 m |
| Type | | i-Stick |
| Number of connectable wireless receivers for i-Stick | | 4 |
| Number of connectable measuring instruments with Integrated Wireless | | 32 |
| For measuring instrument | | MarCal 16 EWRI / 18 EWRI / 30 EWRI MarCator 1086 Ri / 1086 WRi / 1087 Ri / 1087 BRi Micromar 40 EWRI / 40 EWRI-L Millimes 2000 W(i), 2001 W(i) Multimar 25 EWRI Digimar 817 CLT |

MarConnect i-Stick

Receiver for instruments with Integrated Wireless

ACCESSORIES

| Order no. | Description | Type |
|-----------|--|----------|
| 4103400 | Digital caliper, 0 – 150 mm, 0.01 mm | 16 EWRI |
| 4103401 | Digital caliper, 0 – 150 mm, 0.01 mm | 16 EWRI |
| 4103402 | Digital caliper, 0 – 150 mm, 0.01 mm | 16 EWRI |
| 4103403 | Digital caliper, 0 – 150 mm, 0.01 mm | 16 EWRI |
| 4103404 | Digital caliper, 0 – 200 mm, 0.01 mm | 16 EWRI |
| 4103405 | Digital caliper, 0 – 200 mm, 0.01 mm | 16 EWRI |
| 4103406 | Digital caliper, 0 – 300 mm, 0.01 mm | 16 EWRI |
| 4103407 | Digital caliper, 0 – 300 mm, 0.01 mm | 16 EWRI |
| 4112571 | Digital workshop caliper, 0 – 300 mm, 0.01 mm | 18 EWRI |
| 4112572 | Digital workshop caliper, 0 – 500 mm, 0.01 mm | 18 EWRI |
| 4112573 | Digital workshop caliper, 0 – 750 mm, 0.01 mm | 18 EWRI |
| 4112574 | Digital workshop caliper, 0 – 1000 mm, 0.01 mm | 18 EWRI |
| 4126755 | Digital depth gage, 0 – 150 mm, 0.01 mm | 30 EWRI |
| 4126756 | Digital depth gage, 0 – 300 mm, 0.01 mm | 30 EWRI |
| 4126757 | Digital depth gage, 0 – 500 mm, 0.01 mm | 30 EWRI |
| 4119050 | Digital universal calipers, 0 – 300 mm, 0.01 mm | 25 EWRI |
| 4119051 | Digital universal calipers, 0 – 600 mm, 0.01 mm | 25 EWRI |
| 4119052 | Digital universal calipers, 0 – 1000 mm, 0.01 mm | 25 EWRI |
| 4119053 | Digital universal calipers, 0 – 1250 mm, 0.01 mm | 25 EWRI |
| 4337624 | Digital indicator, 0.0005 mm, 12.5mm | 1086 Ri |
| 4337625 | Digital indicator, 0.0005 mm, 25 mm | 1086 Ri |
| 4337626 | Digital indicator, 0.0005 mm, 50 mm | 1086 Ri |
| 4337627 | Digital indicator, 0.0005 mm, 100 mm | 1086 Ri |
| 4337628 | Digital indicator, 0.0005 mm, 25 mm | 1086 Ri |
| 4337134 | Digital indicator, 0.01 mm, 12.5mm | 1086 Ri |
| 4337135 | Digital indicator, 0.01 mm, 25 mm | 1086 Ri |
| 4337136 | Digital indicator, 0.01 mm, 50 mm | 1086 Ri |
| 4337137 | Digital indicator, 0.01 mm, 100 mm | 1086 Ri |
| 4337142 | Digital indicator, 0.0005 mm, 12.5mm | 1086 WRi |
| 4337143 | Digital indicator, 0.0005 mm, 25 mm | 1086 WRi |
| 4337147 | Digital indicator, 0.01 mm, 12.5mm | 1086 WRi |
| 4337148 | Digital indicator, 0.01 mm, 25 mm | 1086 WRi |
| 4337663 | Digital indicator, 0.0005 mm, 12.5mm | 1087 Ri |
| 4337665 | Digital indicator, 0.0005 mm, 25 mm | 1087 Ri |
| 4337664 | Digital indicator, 0.0005 mm, 12.5mm | 1087 BRi |
| 4157100 | Digital bracket micrometer screw, 0 – 25 mm | 40 EWRI |
| 4157101 | Digital micrometer, 25 – 50 mm | 40 EWRI |
| 4157102 | Digital bracket micrometer screw, 50 – 75 mm | 40 EWRI |
| 4157103 | Digital bracket micrometer screw, 75 – 100 mm | 40 EWRI |
| 4346701 | Inductive dial comparator, $\pm 1 \mu\text{m}$ | 2000 Wi |
| 4346801 | Inductive dial comparator, $\pm 1 \mu\text{m}$ | 2001 Wi |
| 4429600 | Digimar 0 – 350 mm | 817 CLT |
| 4429601 | Digimar 0 – 600 mm | 817 CLT |
| 4429602 | Digimar 0 – 1000 mm | 817 CLT |



16 EWRI;
800 SR



30 EWRI



1086 Ri



40 EWRI



1087 Ri



FEATURES

- For upgrading all Mahr handheld measuring instruments with data interface
- Wireless measuring value transfer from measuring equipment to PC
- Secure data transfer thanks to receipt of measuring value confirmation from PC to measuring equipment
- Optical confirmation of receipt at transmission module
- Compact transmission modules without external antenna
- Bidirectional transmission path (remote enquiry from measuring equipment)
- Radio frequency of 2400 MHz
- **Package contains:** e-stick wireless receiver, driver
- **Software:** MarCom Professional free download: www.mahr.com/marcom (only for Mahr data cables and wireless systems with USB and RS-232 interface)



Application:

- Wireless data transmission from a measuring instrument to a PC

TECHNICAL DATA

| | | | |
|---|--|------|--|
| Order no. | 4102230 | | |
| Frequency band | MHz | 2400 | |
| Radio range | Up to 6 m | | |
| Type | e-Stick | | |
| Number of connectable wireless receivers for e-Stick | 1 | | |
| Number of connectable transmission modules for e-Stick | 8 | | |
| For measuring instrument | Transmission modules 16 EWe, 2000 e, RS232 e | | |

ACCESSORIES

| Order no. | Description | Type | For measuring instrument |
|-----------|----------------------------------|----------|--|
| 4102231 | 16 EWe Transmitter for e-Stick | 16 EWe | MarCal 16 ER, 16 EWR, 16 EWW, 18 EWR, 30 EWR, 30 EWN Digimar 814 SR Micromar 40 EWR (≤2017), 40 EWS, 40 EWW, 44 EWR, 46 EWR MarCator 1075 R, 1086 R, 1087 R, 1087 BR MarSurf PS1, PS10 |
| 4102232 | 2000 e Transmitter for e-Stick | 2000 e | Digimar 816 CL MarCator 1088 / 1088W Millimes 2000, 2001, 2100, µMaxum II Millimar C1200 |
| 4102233 | RS-232 e Transmitter for e-Stick | RS-232 e | Millimar C1208, C1216, C1245, S1840, Digimar 817 CLM |



16 EWe



2000 e

MarConnect Opto USB / Millimar - USB / 817 USB / 16 EXu / DK-U1 / MC-I / 800 EWu / 2000 USB / 838 USB



Adapter cable RS232-USB

FEATURES

- For connecting the measuring instrument to a PC
- Data transfer to MarCom or other applications via virtual communication interface
- **Package contains:** USB cable, driver
- **Software:** MarCom Professional free download: www.mahr.com/marcom (only for Mahr data cables and wireless systems with USB and RS-232 interface)



Application:

- Data recorded with PC, laptop or tablet using MS-Windows operating system

TECHNICAL DATA

| Order no. | Cable length | Type | For measuring instrument |
|-----------|--------------|----------------|---|
| | m | | |
| 2121428 | 2 | | Maxum III (E2) |
| 4102330 | 0.2 | Opto USB | Digimar M814 (in conjunction with cable 4102510) Multimar 25 ES (in conjunction with cable 4102510) MarTool 106 ES (in conjunction with cable 4102510) |
| 4102331 | 0.2 | Millimar - USB | Millimar C1208, C1216, 1240, C1240, C1245, S1840, S1841, X1715, X1741, 832 (in conjunction with cable 7024634) |
| 4102333 | 0.2 | 817 USB | Digimar 817 CLM (in conjunction with cable 7024634) |
| 4102357 | 2 | 16 EXu | MarCal 16 ER, 16 EWR, 18 EWR, 30 EWR, 30 EWN Digimar 814 SR Micromar 40 ER, 40 EWR (≤ 2017), 40 EWW, 40 EWS, 44 EWR, 46 EWR MarCator 1075 R, 1086 R, 1086 Ri, 1087 R, 1087 Ri, 1087 BR, 1087 BRi MarSurf PS1, PS10, M300, M300C, PocketSurf IV |
| 4102603 | 2 | DK-U1 | Micromar 40 EWR (≥ 2018) Millimar C 1202 MarSurf M310 Millimes 2000 W(i), 2001 W(i) |
| 4102782 | 0.1 | MC-I | Foot switch 16 ESf |
| 4305121 | 2 | 800 EWu | MarCal 31 EW MarTest 800 EW, 800 EWL |
| 4346023 | 2 | 2000 USB | Digimar 816 CL MarCator 1088, 1088 W Millimes 2000, 2001, 2100, μ Maxum II |
| 4495079 | 1.5 | 838 USB | Marameter 838 EI, 838 EA |

ACCESSORIES

| Order no. | Description | Type |
|-----------|--|---------|
| 4102221 | Wireless remote control for MarCom | MC-R |
| 4102553 | USB-hub 7-fold industrial model | USB-hub |
| 4102058 | Foot switch to trigger data transmission | 16 ESf |



FEATURES

- For connecting the measuring instrument to an interface box or PC
- Data transfer to MarCom or to other applications via communication interface
- **Software:** MarCom Professional free download: www.mahr.com/marcom (only for Mahr data cables and wireless systems with USB and RS-232 interface)



Application:

- Data collection with RS232 compatible devices

TECHNICAL DATA

| Order no. | Cable length | Type | For measuring instrument |
|-----------|--------------|---------|--|
| | m | | |
| 4102410 | 2 | 16 EXr | MarCal 16 ER, 16 EWR, 18 EWR, 30 EWR, 30 EWN Digimar 814 SR Micromar 40 ER, 40 EWR (≤ 2017), 40 EWW, 40 EWS, 44 EWR, 46 EWR MarCator 1075 R, 1086 R, 1086 Ri, 1087 R, 1087 Ri, 1087 BR, 1087 BRi MarSurf PS1, PS10, M300, M300C, PocketSurf IV |
| 4102510 | 2 | 16 ESv | Digimar 814 G, 814 N Multimar 25 ES MarTool 106 ES |
| 4305122 | 2 | 800 EWr | MarCal 31 EW MarTest 800 EW, 800 EWL |
| 4346020 | 2 | 2000 r | Digimar 816 CL MarCator 1088, 1088 W Millimes 2000, 2001, 2100, µMaxum II |
| 7024634 | 3 | | Digimar 817 CLM Millimar C1208, C1216, 1240, C1245, S1840, S1841, X1715, X1745, 832 |

MarConnect DK-D1 / 16 EWd / 2000 d / 838 di (A)



Interface adapter with data cable Digimatic

FEATURES

- For connection to Digimatic compatible interfaces and evaluation equipment



Application:

- Data collection with Digimatic-compatible devices

TECHNICAL DATA

| Order no. | Cable length | Type | Inputs | For measuring instrument |
|-----------|--------------|------------|------------|--|
| | m | | | |
| 2239035 | 2 | | Footswitch | Maxum III dial comparator with 6-pin data output |
| 2239037 | 2 | | | Maxum III μ Indicator with 10-pin output port |
| 4102606 | 2 | DK-D1 | | Micromar 40 EWR (≥ 2018) Millimar C 1202 Millimes 2000 W(i), 2001 W(i) |
| 4102915 | 2 | 16 EWd | | MarCal 16 ER, 16 EWR, 18 EWR, 30 EWR, 30 EWN Digimar 814 SR Micromar 40 ER, 40 EWR (≤ 2017), 40 EWW, 40 EWS, 44 EWR, 46 EWR MarCator 1075 R, 1086 R, 1086 Ri, 1087 R, 1087 Ri, 1087 BR, 1087 BRi MarSurf PS1, M300, M300C |
| 4346021 | 2 | 2000 d | | Digimar 816 CL MarCator 1088, 1088 W Millimes 2000, 2001, 2100, μ Maxum II Millimar C1200 |
| 4495083 | 1.5 | 838 di (A) | | Marameter 838 EI, 838 EA |

MarCal | Calipers

Calipers are some of the most important measuring instruments in production metrology because they are both versatile and easy to use. Digital devices are simple to operate, easy to read, and data acquisition is fast and uncomplicated.



| | |
|--|-----------|
| Overview MarCal calipers | 20 |
| MarCal 16 EWRI / 16 EWR / 16 ER Digital calipers | 24 |
| MarCal 16 U Dial calipers | 29 |
| MarCal 16 FN / 16 GN / 16 DN With scale display | 30 |
| MarCal 18 EWRI / 18 EWR / 18 ESA Digital workshop calipers | 32 |
| MarCal 18 NA Workshop calipers | 35 |
| MarCal 16 EWRI-V / 16 EWR-V / 18 EWR-V Digital universal calipers | 36 |
| Digital special calipers Digital calipers for special applications | 42 |
| MarCal 30 EWRI / 30 EWR Digital depth gages | 56 |
| MarCal 30 EWRI-D / 30 EWR-D / 30 EWRI-N / 30 EWR-N Digital depth gages | 58 |

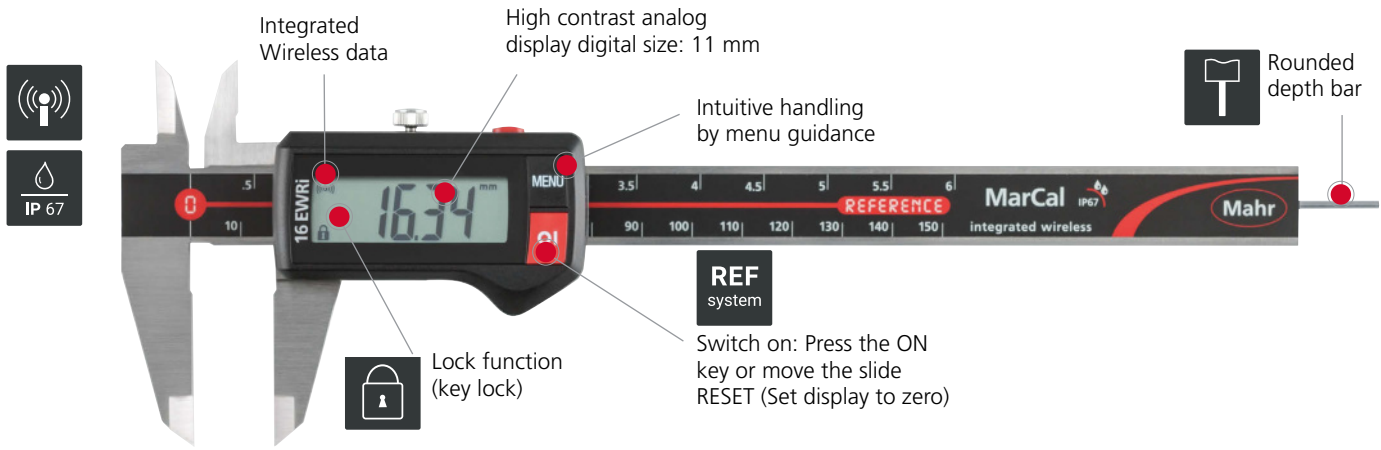
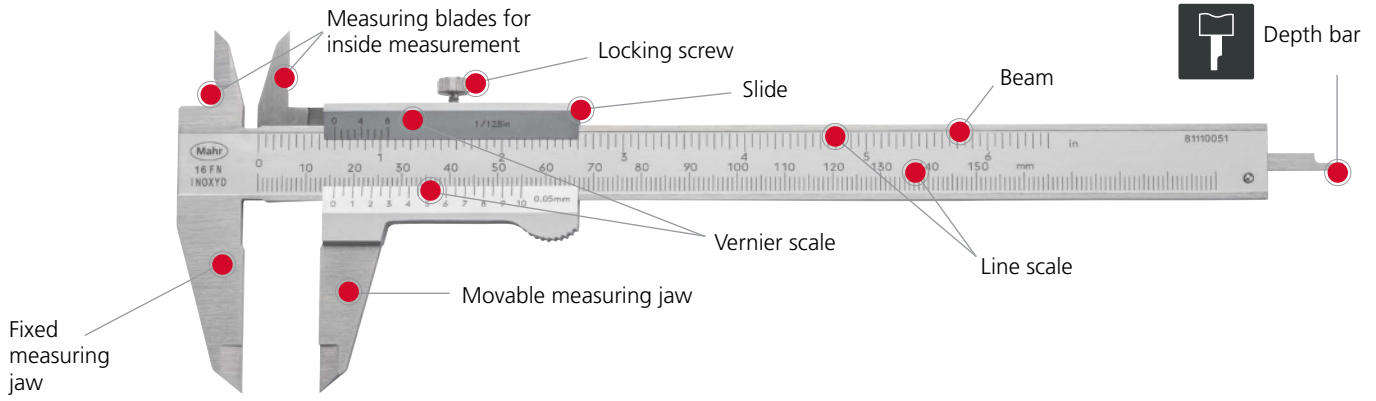

MarCal | Types of measurement

16 series calipers (e.g. 16 EWri, 16 U, 16 FN) can be used to conduct 4 different types of measurements:

a) Outside measurement

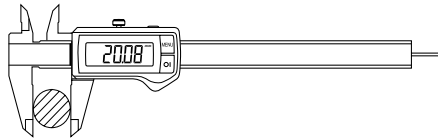

b) Inside measurement

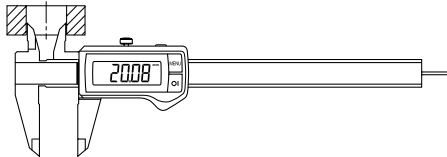

c) Depth measurement

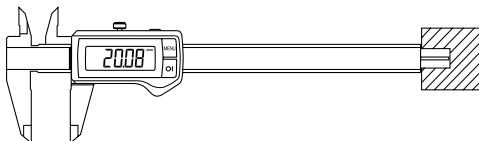

d) Step (distance) measurement

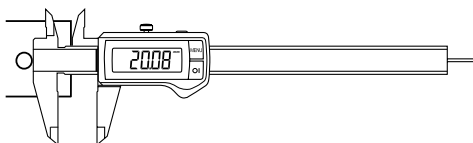

Error limits G according to DIN 862

| Measuring length | Error limits G in μm | | |
|------------------|--|------|------------|
| | Scale interval and/or vernier interval | | Resolution |
| mm | 0.1 and 0.05 | 0.02 | 0.01 |
| 50 | 50 | 20 | 20 |
| 100 | | | |
| 200 | | | |
| 300 | 60 | 30 | 30 |
| 400 | | | |
| 500 | | | |
| 600 | 80 | 40 | 40 |
| 700 | | | |
| 800 | | | |
| 900 | 110 | 40 | 40 |
| 1000 | | | |
| 1200 | | | |
| 1400 | 140 | 50 | — |
| 1600 | | | |
| 1800 | | | |
| 2000 | 220 | 60 | — |

MarCal - The innovative Reference System



All Mahr digital calipers with this REF system logo are equipped with the innovative Reference System. The zero position only has to be set once: after setting the zero position, the zero remains stored for all further measurements. Therefore, once the caliper is switched ON or the slide is moved, the caliper is immediately ready for measurement. Once the caliper is initially set to zero, there is no need to reset to zero each time the caliper is turned on.

Conventional

- ① Switch ON
- ② Close the measuring jaws
- ③ Set to zero
- ④ Results of measurement

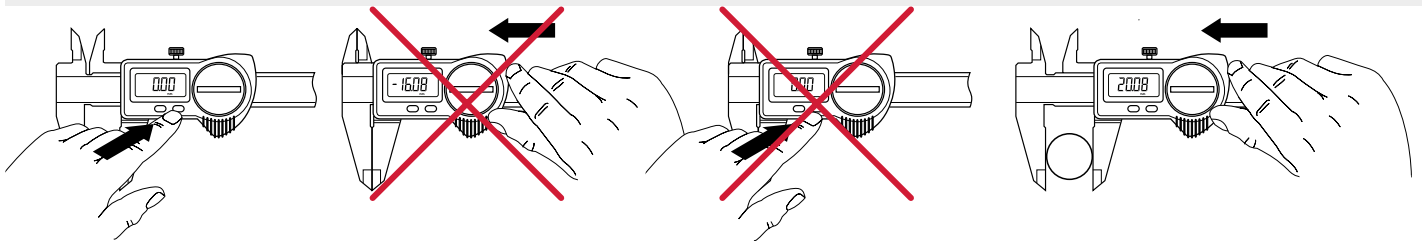

- ① Switch ON
- ② Results of measurement

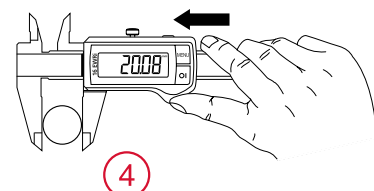
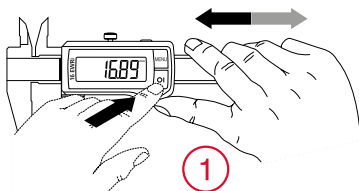

Press the ON key

or

move the slide

IP Protection classes

First digital is the degree of protection according to IEC 60529 – against particles, contaminants and dust

- 0 Not protected
- 1 Particles > 50.0 mm
- 2 Particles > 12.5 mm
- 3 Particles > 2.5 mm
- 4 Particles > 1.0 mm
- 5 Dust protected
- 6 Dust tight

Second digital is the degree of protection according to IEC 60529 (approximate) – against wet conditions (fluids)

- 0 Not protected
- 1 Falling water drops - vertical
- 2 Falling water drops - tilted < 15°
- 3 Spray water < 60°
- 4 Water splashing from all directions
- 5 Water jets from all directions
- 6 Powerful water jets
- 7 Temporary immersion in water
- 8 Continuous immersion under pressure



Example
IP67 means that the product is dust tight and is protected against temporary immersion in water.

MarCal | The new generation Waterproof digital calipers with the Reference System and Integrated Wireless

Security due to the Reference Lock function

- Zero-position is secured
- Operating error is not possible

The MarCal 16 EWRi digital caliper with the Reference System is equipped with a LOCK function. With this key lock, the zero position is secured and operating error is avoided.



Battery service life is 3 years

The Reference System is extremely energy efficient because of its standby mode feature; almost no power is required, thus extending the life of the battery up to 3 years*.

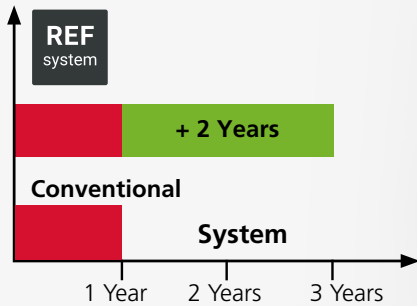

* When Integrated Wireless is deactivated

Superior quality of the guideways

Only MarCal calipers have lapped guideway surfaces that guarantee an even and sensitive run of the slide. Additionally, the service life of the caliper increases, compared to a ground guideway due to the greater contact area on the guideway surface.



Surface of the guideway

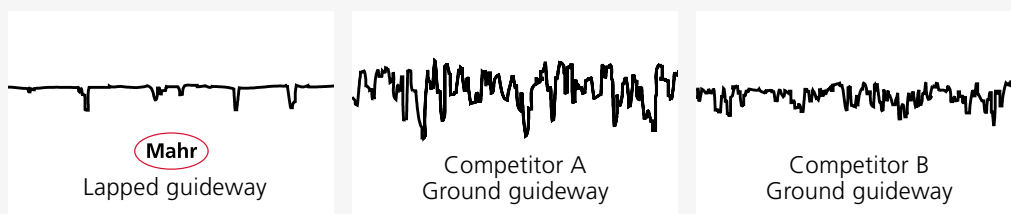

MarConnect Integrated Wireless



Wireless data transmission for the price of a data cable.

With Mahr's Integrated Wireless, users have a new Integrated Wireless data transmission system for the price of a data cable. Data acquisition with digital calipers is now even simpler: simply transmit your measured data directly into Microsoft Office Excel® or any Windows program with a keyboard code.

Secure data transmission



With Integrated Wireless, your data will be transferred to the digital indicator, which is confirmed with a message on the digital indicator's display. The message will show whether the sent data has been transferred correctly, and/or whether you are in the reception range of the i-Stick.

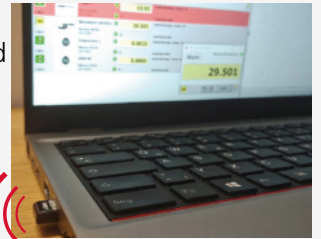

Ergonomic design

The handy non-slip thumb support of the MarCal 16 EWRi ensures, even in contaminated working conditions, trouble-free handling and therefore reliable measuring results.



Original size 11 mm



The high-contrast display with 11 mm sized digitals enables accurate, fatigue-free reading of the measurement results.

Excellent resistance against dust, coolant and lubricants



Due to the outstanding protection against dust and water, the MarCal 16 EWRi digital caliper with the Reference System delivers precise and secure results, even in the most difficult workshop conditions. The finished plastic components have an outstanding chemical resistance.

| | | |
|----------------|-----------|--|
| Code Initials | IP | International Protection |
| First digital | 6 | Dust-tight |
| Second digital | 7 | Protected against temporary immersion in water |





FUNCTIONS

- ON/OFF
- AUTO-ON / OFF
- HOLD (storage of measured values)
- RESET (set display to zero)
- PRESET (for entering a numerical value)
- Reversal of counting direction
- mm/inch
- LOCK function (key lock)
- DATA (data transmission)



FEATURES

- High contrast digital display
- Locking screw above
- Lapped guideway
- Measuring blade for inside measurements
- Slide and beam made of hardened stainless steel
- Step measuring function
- Immediate measurements due to the Reference System
- Raised guideway for the protection of the scale
- Excellent resistance against dust, coolants and lubricants
- Dirt wipers are integrated in the slide
- Software: MarCom Professional free download: www.mahr.com/marcom (only for Mahr data cables and wireless systems with USB and RS-232 interface)
- **Digital height:** 11 mm
- **Data interface:** Integrated Wireless
- **Energy supply:** Battery life approx. 3 years (approx. 0.5 in wireless mode)
- **Battery type:** CR 2032 (3V Lithium)
- **IP protection category:** IP 67
- **Package contains:** battery, instruction manual, case

TECHNICAL DATA

| Order no. | Type | Measuring range | | Resolution | Error limit | Standard | Depth rod | Friction wheel |
|-----------|---------|-----------------|---------|---------------|-------------|------------------|-------------|----------------|
| | | mm | inch | | | | | |
| 4103400 | 16 EWri | 0 – 150 | 0 – 6" | 0.01 / .0005" | 0.03 | DIN 862 | round | |
| 4103401 | 16 EWri | 0 – 150 | 0 – 6" | 0.01 / .0005" | 0.03 | DIN 862 | round | • |
| 4103402 | 16 EWri | 0 – 150 | 0 – 6" | 0.01 / .0005" | 0.03 | DIN 862 | rectangular | |
| 4103403 | 16 EWri | 0 – 150 | 0 – 6" | 0.01 / .0005" | 0.03 | DIN 862 | rectangular | • |
| 4103404 | 16 EWri | 0 – 200 | 0 – 8" | 0.01 / .0005" | 0.03 | DIN 862 | rectangular | |
| 4103405 | 16 EWri | 0 – 200 | 0 – 8" | 0.01 / .0005" | 0.03 | DIN 862 | rectangular | • |
| 4103406 | 16 EWri | 0 – 300 | 0 – 12" | 0.01 / .0005" | 0.04 | Factory standard | | |
| 4103407 | 16 EWri | 0 – 300 | 0 – 12" | 0.01 / .0005" | 0.04 | Factory standard | | • |

| Order no. | a | b | c | d | e |
|-----------|----|----|----|-----|----|
| | mm | mm | mm | mm | mm |
| 4103400 | 10 | 40 | 16 | 235 | 16 |
| 4103401 | 10 | 40 | 16 | 235 | 16 |
| 4103402 | 10 | 40 | 16 | 235 | 16 |
| 4103403 | 10 | 40 | 16 | 235 | 16 |
| 4103404 | 10 | 50 | 19 | 285 | 16 |
| 4103405 | 10 | 50 | 19 | 285 | 16 |
| 4103406 | 14 | 64 | 19 | 388 | 16 |
| 4103407 | 14 | 64 | 19 | 388 | 16 |

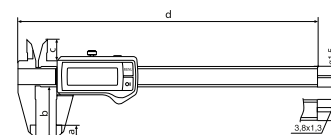

ACCESSORIES

| Order no. | Description | Type |
|-----------|---|---------|
| 4102020 | Depth bridge (75 x 7 mm) | 16 Em |
| 4102220 | Receiver for instruments with Integrated Wireless | i-Stick |

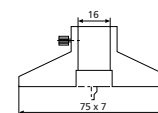

16 Em



i-Stick

MarCal 16 EWR

Digital caliper



FUNCTIONS

- ON/OFF
- AUTO-ON / OFF
- RESET (set display to zero)
- PRESET (for entering a numerical value)
- Reversal of counting direction
- mm/inch
- LOCK function (key lock)

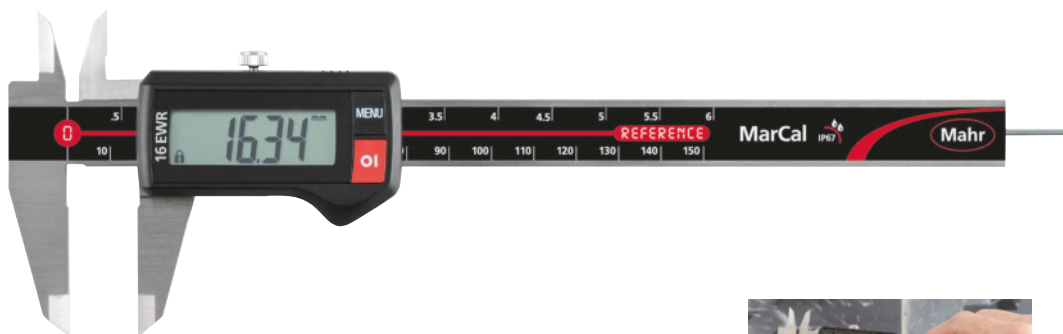

FEATURES

- High contrast digital display
- Locking screw above
- Lapped guideway
- Measuring blade for inside measurements
- Slide and beam made of hardened stainless steel
- Step measuring function
- Immediate measurements due to the Reference System
- Raised guideway for the protection of the scale
- Excellent resistance against dust, coolants and lubricants
- Dirt wipers are integrated in the slide
- **Digital height:** 11 mm
- **Data interface:** none
- **Energy supply:** Battery life approx. 3 years
- **Battery type:** CR 2032 (3V Lithium)
- **IP protection category:** IP 67
- **Package contains:** battery, instruction manual, case



TECHNICAL DATA

| Order no. | Type | Measuring range | Measuring range | Resolution | Error limit | Standard | Depth rod | Friction wheel |
|-----------|--------|-----------------|-----------------|---------------|-------------|------------------|-------------|----------------|
| | | mm | inch | mm/inch | mm | | | |
| 4103300 | 16 EWR | 0–150 | 0–6" | 0.01 / .0005" | 0.03 | DIN 862 | round | |
| 4103301 | 16 EWR | 0–150 | 0–6" | 0.01 / .0005" | 0.03 | DIN 862 | round | • |
| 4103302 | 16 EWR | 0–150 | 0–6" | 0.01 / .0005" | 0.03 | DIN 862 | rectangular | |
| 4103303 | 16 EWR | 0–150 | 0–6" | 0.01 / .0005" | 0.03 | DIN 862 | rectangular | • |
| 4103304 | 16 EWR | 0–200 | 0–8" | 0.01 / .0005" | 0.03 | DIN 862 | rectangular | |
| 4103305 | 16 EWR | 0–200 | 0–8" | 0.01 / .0005" | 0.03 | DIN 862 | rectangular | • |
| 4103306 | 16 EWR | 0–300 | 0–12" | 0.01 / .0005" | 0.04 | Factory standard | | |
| 4103307 | 16 EWR | 0–300 | 0–12" | 0.01 / .0005" | 0.04 | Factory standard | | • |

| Order no. | a | b | c | d | e |
|-----------|----|----|----|-----|----|
| | mm | mm | mm | mm | mm |
| 4103300 | 10 | 40 | 16 | 235 | 16 |
| 4103301 | 10 | 40 | 16 | 235 | 16 |
| 4103302 | 10 | 40 | 16 | 235 | 16 |
| 4103303 | 10 | 40 | 16 | 235 | 16 |
| 4103304 | 10 | 50 | 19 | 285 | 16 |
| 4103305 | 10 | 50 | 19 | 285 | 16 |
| 4103306 | 14 | 64 | 19 | 388 | 16 |
| 4103307 | 14 | 64 | 19 | 388 | 16 |

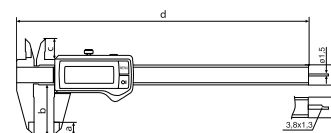

ACCESSORIES

| Order no. | Description | Type |
|-----------|--------------------------|-------|
| 4102020 | Depth bridge (75 x 7 mm) | 16 Em |

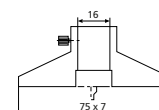

16 Em

MarCal 16 EWR

Digital caliper



FUNCTIONS

- ON/OFF
- AUTO-ON / OFF
- RESET (set display to zero)
- mm/inch
- LOCK function (key lock)
- DATA (data transmission via connection cable)

FEATURES

- High contrast digital display
- Locking screw above
- Lapped guideway
- Measuring blade for inside measurements
- Slide and beam made of hardened stainless steel
- Step measuring function
- Immediate measurements due to the Reference System
- Raised guideway for the protection of the scale
- Excellent resistance against dust, coolants and lubricants
- Dirt wipers are integrated in the slide
- **Software:** MarCom Professional free download: www.mahr.com/marcom (only for Mahr data cables and wireless systems with USB and RS-232 interface)
- **Digital height:** 8.5 mm
- **Data interface:** USB, Opto RS-232C, Digimatic
- **Energy supply:** Battery life approx. 3 years
- **Battery type:** CR 2032 (3V Lithium)
- **IP protection category:** IP 67
- **Package contains:** battery, instruction manual, case

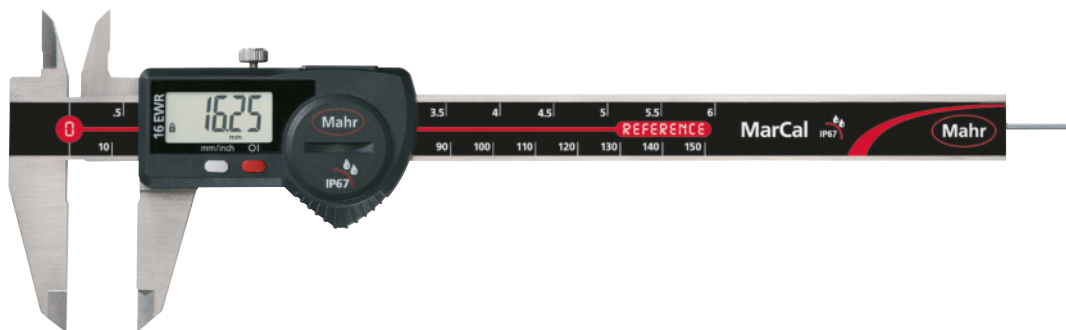

TECHNICAL DATA

| Order no. | Type | Measuring range | | Resolution | Error limit | Standard | Depth rod | Friction wheel |
|-----------|--------|-----------------|-------|---------------|-------------|------------------|-------------|----------------|
| | | mm | inch | | | | | |
| 4103064 | 16 EWR | 0–150 | 0–6" | 0.01 / .0005" | 0.03 | DIN 862 | round | |
| 4103065 | 16 EWR | 0–150 | 0–6" | 0.01 / .0005" | 0.03 | DIN 862 | round | • |
| 4103066 | 16 EWR | 0–150 | 0–6" | 0.01 / .0005" | 0.03 | DIN 862 | rectangular | |
| 4103067 | 16 EWR | 0–150 | 0–6" | 0.01 / .0005" | 0.03 | DIN 862 | rectangular | • |
| 4103068 | 16 EWR | 0–200 | 0–8" | 0.01 / .0005" | 0.03 | DIN 862 | rectangular | |
| 4103069 | 16 EWR | 0–200 | 0–8" | 0.01 / .0005" | 0.03 | DIN 862 | rectangular | • |
| 4103070 | 16 EWR | 0–300 | 0–12" | 0.01 / .0005" | 0.04 | Factory standard | | |
| 4103071 | 16 EWR | 0–300 | 0–12" | 0.01 / .0005" | 0.04 | Factory standard | | • |

| Order no. | a | b | c | d | e |
|-----------|----|----|----|-----|----|
| | mm | mm | mm | mm | mm |
| 4103064 | 10 | 40 | 16 | 235 | 16 |
| 4103065 | 10 | 40 | 16 | 235 | 16 |
| 4103066 | 10 | 40 | 16 | 235 | 16 |
| 4103067 | 10 | 40 | 16 | 235 | 16 |
| 4103068 | 10 | 50 | 19 | 285 | 16 |
| 4103069 | 10 | 50 | 19 | 285 | 16 |
| 4103070 | 14 | 64 | 19 | 388 | 16 |
| 4103071 | 14 | 64 | 19 | 388 | 16 |

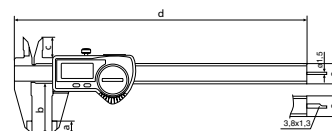

ACCESSORIES

| Order no. | Description | Type |
|-----------|---|--------|
| 4102020 | Depth bridge (75 x 7 mm) | 16 Em |
| 4102357 | 16 EXu data connection cable USB (2 m) | 16 EXu |
| 4102410 | Data connection cable RS232C (2 m) | 16 EXr |
| 4102915 | Interface adapter with data cable Digimatic (2 m) | 16 EWd |

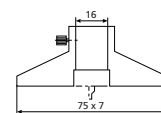

16 Em

MarCal 16 ER

Digital caliper



FUNCTIONS

- ON/OFF
- AUTO-ON / OFF
- RESET (set display to zero)
- mm/inch
- LOCK function (key lock)

FEATURES

- High contrast digital display
- Locking screw above
- Lapped guideway
- Measuring blade for inside measurements
- Slide and beam made of hardened stainless steel
- Step measuring function
- Immediate measurements due to the Reference System
- Raised guideway for the protection of the scale
- Dirt wipers are integrated in the slide
- **Digital height:** 11 mm
- **Data interface:** none
- **Energy supply:** Battery life approx. 3 years
- **Battery type:** CR 2032 (3V Lithium)
- **IP protection category:** None
- **Package contains:** instruction manual, battery, case

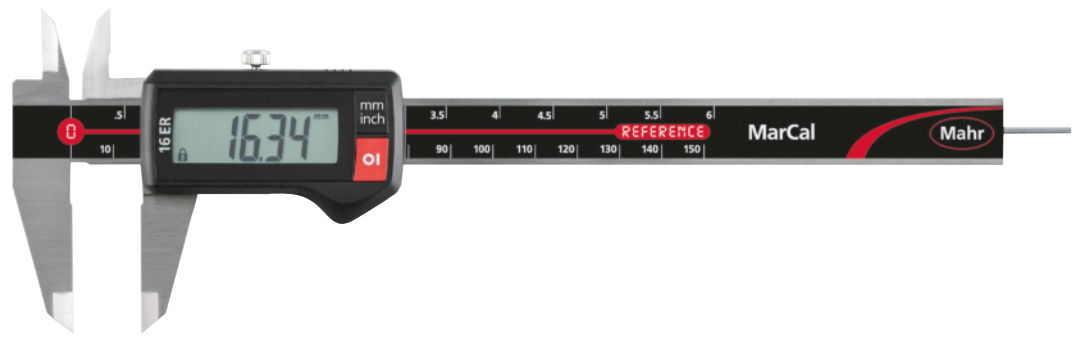

TECHNICAL DATA

| Order no. | Type | Measuring range | | Resolution | Error limit | Standard | Depth rod | Friction wheel |
|-----------|-------|-----------------|-------|---------------|-------------|------------------|-------------|----------------|
| | | mm | inch | | | | | |
| 4103010 | 16 ER | 0-150 | 0-6" | 0.01 / .0005" | 0.03 | DIN 862 | round | |
| 4103011 | 16 ER | 0-150 | 0-6" | 0.01 / .0005" | 0.03 | DIN 862 | round | • |
| 4103012 | 16 ER | 0-150 | 0-6" | 0.01 / .0005" | 0.03 | DIN 862 | rectangular | |
| 4103013 | 16 ER | 0-150 | 0-6" | 0.01 / .0005" | 0.03 | DIN 862 | rectangular | • |
| 4103205 | 16 ER | 0-200 | 0-8" | 0.01 / .0005" | 0.03 | DIN 862 | rectangular | |
| 4103206 | 16 ER | 0-200 | 0-8" | 0.01 / .0005" | 0.03 | DIN 862 | rectangular | • |
| 4103207 | 16 ER | 0-300 | 0-12" | 0.01 / .0005" | 0.04 | Factory standard | | |
| 4103208 | 16 ER | 0-300 | 0-12" | 0.01 / .0005" | 0.04 | Factory standard | | • |

| Order no. | a | b | c | d | e |
|-----------|----|----|----|-----|----|
| | mm | mm | mm | mm | mm |
| 4103010 | 10 | 40 | 16 | 235 | 16 |
| 4103011 | 10 | 40 | 16 | 235 | 16 |
| 4103012 | 10 | 40 | 16 | 235 | 16 |
| 4103013 | 10 | 40 | 16 | 235 | 16 |
| 4103205 | 10 | 50 | 19 | 285 | 16 |
| 4103206 | 10 | 50 | 19 | 285 | 16 |
| 4103207 | 14 | 64 | 19 | 388 | 16 |
| 4103208 | 14 | 64 | 19 | 388 | 16 |

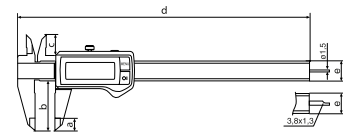

ACCESSORIES

| Order no. | Description | Type |
|-----------|--------------------------|-------|
| 4102020 | Depth bridge (75 x 7 mm) | 16 Em |

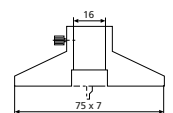

16 Em

MarCal 16 ER

Digital caliper



FUNCTIONS

- ON/OFF
- AUTO-ON / OFF
- RESET (set display to zero)
- mm/inch
- LOCK function (key lock)
- DATA (data transmission via connection cable)

FEATURES

- High contrast digital display
- Locking screw above
- Lapped guideway
- Measuring blade for inside measurements
- Slide and beam made of hardened stainless steel
- Step measuring function
- Immediate measurements due to the Reference System
- Raised guideway for the protection of the scale
- Dirt wipers are integrated in the slide
- **Software:** MarCom Professional free download: www.mahr.com/marcom (only for Mahr data cables and wireless systems with USB and RS-232 interface)
- **Digital height:** 8.5 mm
- **Data interface:** USB, Opto RS-232C, Digimatic
- **Energy supply:** Battery life approx. 3 years
- **Battery type:** CR 2032 (3V Lithium)
- **IP protection category:** None
- **Package contains:** instruction manual, battery, case

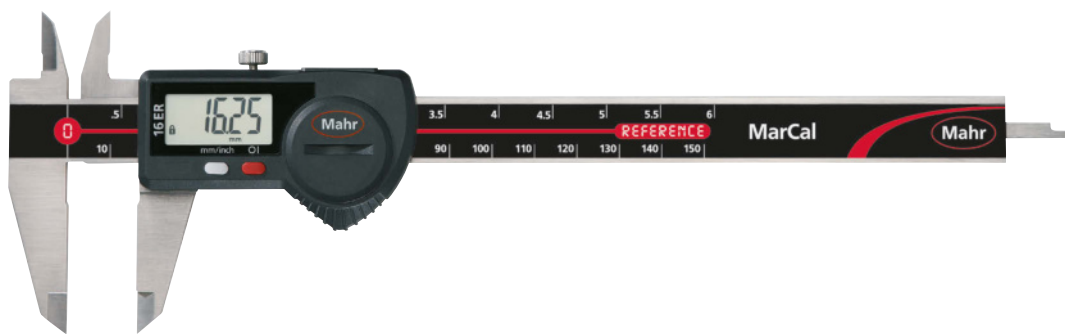

TECHNICAL DATA

| Order no. | Type | Measuring range | Measuring range | Resolution | Error limit | Standard | Depth rod | Friction wheel |
|-----------|-------|-----------------|-----------------|---------------|-------------|------------------|-------------|----------------|
| | | mm | inch | mm/inch | mm | | | |
| 4103014 | 16 ER | 0–150 | 0–6" | 0.01 / .0005" | 0.03 | DIN 862 | round | |
| 4103015 | 16 ER | 0–150 | 0–6" | 0.01 / .0005" | 0.03 | DIN 862 | round | • |
| 4103016 | 16 ER | 0–150 | 0–6" | 0.01 / .0005" | 0.03 | DIN 862 | rectangular | |
| 4103017 | 16 ER | 0–150 | 0–6" | 0.01 / .0005" | 0.03 | DIN 862 | rectangular | • |
| 4103018 | 16 ER | 0–200 | 0–8" | 0.01 / .0005" | 0.03 | DIN 862 | rectangular | • |
| 4103019 | 16 ER | 0–200 | 0–8" | 0.01 / .0005" | 0.03 | DIN 862 | rectangular | • |
| 4103020 | 16 ER | 0–300 | 0–12" | 0.01 / .0005" | 0.04 | Factory standard | | |
| 4103021 | 16 ER | 0–300 | 0–12" | 0.01 / .0005" | 0.04 | Factory standard | | • |

| Order no. | a | b | c | d | e |
|-----------|----|----|----|-----|----|
| | mm | mm | mm | mm | mm |
| 4103014 | 10 | 40 | 16 | 235 | 16 |
| 4103015 | 10 | 40 | 16 | 235 | 16 |
| 4103016 | 10 | 40 | 16 | 235 | 16 |
| 4103017 | 10 | 40 | 16 | 235 | 16 |
| 4103018 | 10 | 50 | 19 | 285 | 16 |
| 4103019 | 10 | 50 | 19 | 285 | 16 |
| 4103020 | 14 | 64 | 19 | 388 | 16 |
| 4103021 | 14 | 64 | 19 | 388 | 16 |

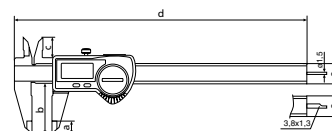

ACCESSORIES

| Order no. | Description | Type |
|-----------|---|--------|
| 4102020 | Depth bridge (75 x 7 mm) | 16 Em |
| 4102357 | 16 EXu Data connection cable USB (2 m) | 16 EXu |
| 4102410 | Data connection cable RS232C (2 m) | 16 EXr |
| 4102915 | Interface Adapter with data cable digimatic (2 m) | 16 EWd |

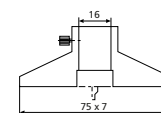

16 Em

MarCal 16 U

Dial caliper



SHOCK
PROOF

DIN
862

FEATURES

- Large, high contrast dial face
- Shockproof movement
- Zero setting through rotating the dial face and locking screw
- Satin chrome finished line scale
- Locking screw above
- Measuring surfaces made of steel
- Measuring blade for inside measurements
- Slide and beam made of hardened stainless steel
- Step measuring function
- Raised guideway for the protection of the scale
- Package contains: case



TECHNICAL DATA

| Order no. | Type | Measuring range | Readings | Range per turn | Error limit | Standard | Depth rod | Friction wheel |
|-----------|------|-----------------|----------|----------------|-------------|----------|-------------|----------------|
| | | mm | | mm | mm | | | |
| 4107005 | 16 U | 0–150 | 0.01 | 1 | 0.03 | DIN 862 | rectangular | • |
| 4107107 | 16 U | 0–150 | 0.02 | 2 | 0.03 | DIN 862 | rectangular | • |

| Order no. | a | b | c | d | e |
|-----------|----|----|------|-----|----|
| | mm | mm | mm | mm | mm |
| 4107005 | 10 | 40 | 16.5 | 234 | 16 |
| 4107107 | 10 | 40 | 16.5 | 234 | 16 |

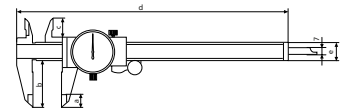

ACCESSORIES

| Order no. | Description | Type |
|-----------|--|-------|
| 4100302 | Synthetic leather pouch, black for pocket slide caliper 150 mm | |
| 4102020 | Depth bridge (75 x 7 mm) | 16 Em |

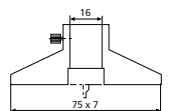

16 Em



FEATURES

- Vernier and scale have a satin chrome finish for glare free reading
- Locking screw above
- Measuring surfaces made of steel
- Measuring blade for inside measurements
- Slide and beam made of hardened stainless steel
- Step measuring function
- Raised guideway for the protection of the scale
- **Package contains:** thread table, case

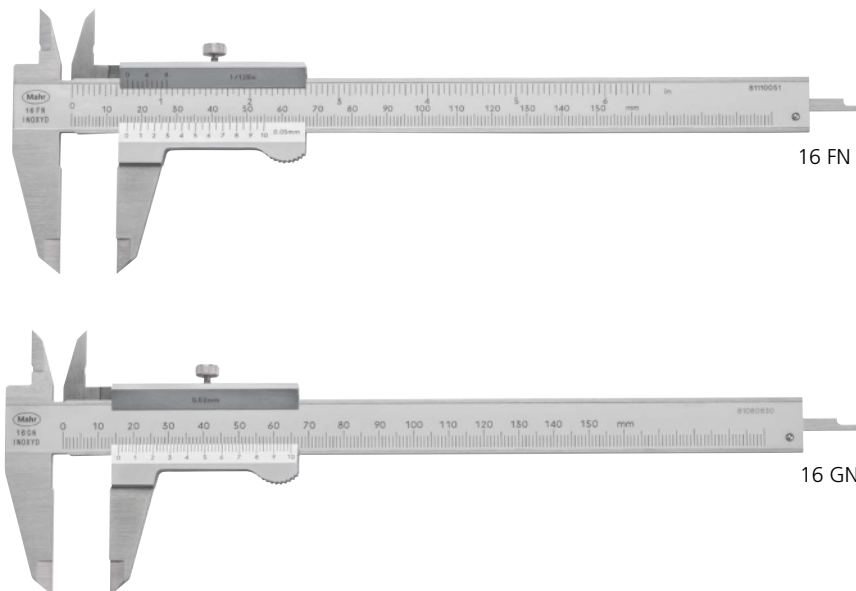

TECHNICAL DATA

| Order no. | Type | Measuring range | | Vernier value | | Error limit | | Standard | Depth rod |
|-----------|-------|-----------------|---------|---------------|--------|-------------|-------|------------------|-------------|
| | | mm | inch | mm | inch | mm | inch | | |
| 4100400 | 16 FN | 0 – 150 | 0 – 6" | 0.05 | 1/128" | 0.05 | 0.002 | DIN 862 | rectangular |
| 4100401 | 16 FN | 0 – 200 | 0 – 8" | 0.05 | 1/128" | 0.05 | 0.002 | DIN 862 | rectangular |
| 4100402 | 16 FN | 0 – 300 | 0 – 12" | 0.05 | 1/128" | 0.05 | 0.002 | DIN 862 | rectangular |
| 4100420 | 16 FN | 0 – 150 | | 0.05 | | 0.05 | | DIN 862 | rectangular |
| 4100421 | 16 FN | 0 – 200 | | 0.05 | | 0.05 | | DIN 862 | rectangular |
| 4100422 | 16 FN | 0 – 300 | | 0.05 | | 0.05 | | DIN 862 | rectangular |
| 4100650 | 16 GN | 0 – 150 | | 0.02 | | 0.05 | | Factory standard | rectangular |
| 4100651 | 16 GN | 0 – 200 | | 0.02 | | 0.05 | | Factory standard | rectangular |
| 4100652 | 16 GN | 0 – 300 | | 0.02 | | 0.05 | | Factory standard | rectangular |

| Order no. | a | b | c | d | e | f |
|-----------|----|----|----|-----|----|-----|
| | mm | mm | mm | mm | mm | mm |
| 4100400 | 10 | 40 | 16 | 228 | 16 | 3.8 |
| 4100401 | 14 | 50 | 19 | 290 | 17 | 3.8 |
| 4100402 | 16 | 64 | 23 | 404 | 20 | 4.8 |
| 4100420 | 10 | 40 | 16 | 228 | 16 | 3.8 |
| 4100421 | 14 | 50 | 19 | 290 | 17 | 3.8 |
| 4100422 | 16 | 64 | 23 | 404 | 20 | 4.8 |
| 4100650 | 10 | 40 | 16 | 228 | 16 | 3.8 |
| 4100651 | 14 | 50 | 19 | 290 | 17 | 3.8 |
| 4100652 | 16 | 64 | 23 | 404 | 20 | 4.8 |

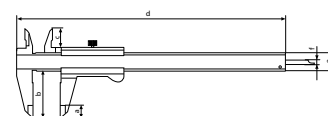

ACCESSORIES

| Order no. | Description | Type |
|-----------|--|-------|
| 4100302 | Synthetic leather pouch, black for pocket slide caliper 150 mm | |
| 4102020 | Depth bridge (75 x 7 mm) | 16 Em |

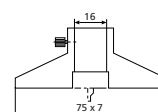

16 Em

MarCal 16 DN

Caliper with analog display



FEATURES

- Vernier and scale have a satin chrome finish for glare free reading
- Thumb clamp
- Measuring surfaces made of steel
- Measuring blade for inside measurements
- Slide and beam made of hardened stainless steel
- Step measuring function
- Raised guideway for the protection of the scale
- **Package contains:** thread table, case

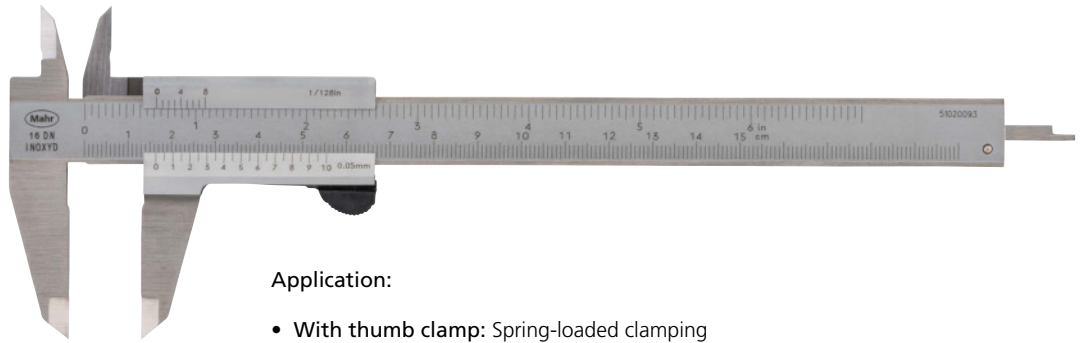

Application:

- **With thumb clamp:** Spring-loaded clamping lever causes self-locking of the slide when the thumb contact is released

TECHNICAL DATA

| Order no. | Type | Measuring range | Measuring range | Vernier value | Vernier value | Error limit | Error limit | Standard | Depth rod |
|-----------|-------|-----------------|-----------------|---------------|---------------|-------------|-------------|----------|-------------|
| | | mm | inch | mm | inch | mm | inch | | |
| 4100600 | 16 DN | 0–150 | 0–6" | 0.05 | 1/128" | 0.05 | 0.002 | DIN 862 | rectangular |

| Order no. | a | b | c | d | e | f |
|-----------|----|----|----|-----|----|-----|
| | mm | mm | mm | mm | mm | mm |
| 4100600 | 10 | 40 | 16 | 228 | 16 | 3.8 |

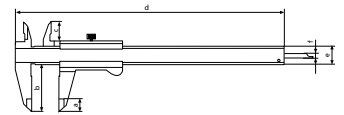

ACCESSORIES

| Order no. | Description | Type |
|-----------|--|-------|
| 4100302 | Synthetic leather pouch, black for pocket slide caliper 150 mm | |
| 4102020 | Depth bridge (75 x 7 mm) | 16 Em |

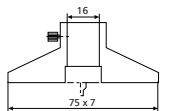

16 Em

FUNCTIONS

- ON/OFF
- AUTO-ON / OFF
- HOLD (storage of measured values)
- RESET (set display to zero)
- PRESET (for entering a numerical value)
- Reversal of counting direction
- mm/inch
- LOCK function (key lock)
- DATA (data transmission)

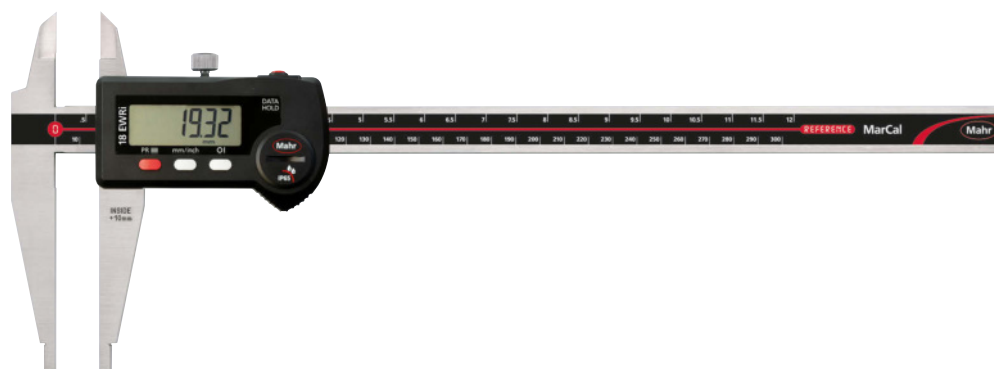

FEATURES

- High contrast digital display
- Locking screw above
- Rounded measuring blades for inside measurements
- Slide and beam made of hardened stainless steel
- Immediate measurements due to the Reference System
- Raised guideway for the protection of the scale
- Excellent resistance against dust, coolants and lubricants
- Dirt wipers are integrated in the slide
- **Software:** MarCom Professional free download: www.mahr.com/marcom (only for Mahr data cables and wireless systems with USB and RS-232 interface)
- **Digital height:** 12,5 mm
- **Data interface:** Integrated Wireless
- **Energy supply:** Battery life approx. 3 years (approx. 0.5 in wireless mode)
- **Battery type:** CR 2032 (3V Lithium)
- **IP protection category:** IP 65
- **Package contains:** battery, instruction manual, case

TECHNICAL DATA

| Order no. | Type | Measuring range | Measuring range | Resolution | Measuring blades for outside measurements | Error limit | Standard |
|-----------|---------|-----------------|-----------------|---------------|---|-------------|------------------|
| | | mm | inch | mm/inch | | mm | |
| 4112571 | 18 EWri | 0 – 300 | 0 – 12" | 0.01 / .0005" | • | 0.03 | Factory standard |
| 4112572 | 18 EWri | 0 – 500 | 0 – 20" | 0.01 / .0005" | • | 0.04 | Factory standard |
| 4112573 | 18 EWri | 0 – 750 | 0 – 30" | 0.01 / .0005" | • | 0.05 | Factory standard |
| 4112574 | 18 EWri | 0 – 1000 | 0 – 40" | 0.01 / .0005" | • | 0.06 | Factory standard |

| Order no. | a | b | c | d | e | f |
|-----------|------|-----|----|----|----|----|
| | mm | mm | mm | mm | mm | mm |
| 4112571 | 430 | 90 | 10 | 10 | 20 | 40 |
| 4112572 | 650 | 150 | 20 | 20 | 25 | 55 |
| 4112573 | 905 | 150 | 20 | 20 | 25 | 55 |
| 4112574 | 1165 | 150 | 20 | 20 | 30 | 60 |

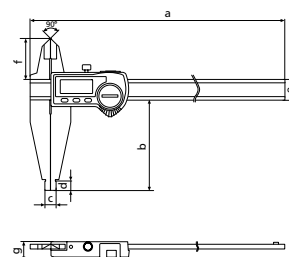

ACCESSORIES

| Order no. | Description | Type |
|-----------|---|---------|
| 4102220 | Receiver for instruments with Integrated Wireless | i-Stick |



i-Stick

MarCal 18 EWR

Digital workshop caliper



FUNCTIONS

- AUTO-ON / OFF
- DATA (data transmission via connection cable)
- ON/OFF
- PRESET (for entering a numerical value)
- RESET (set display to zero)
- mm/inch
- LOCK function (key lock)
- High contrast digital display
- Locking screw above
- Rounded measuring blades for inside measurements
- Slide and beam made of hardened stainless steel
- Immediate measurements due to the Reference System
- Raised guideway for the protection of the scale
- Excellent resistance against dust, coolants and lubricants
- Dirt wipers are integrated in the slide



FEATURES

- **Software:** MarCom Professional free download: www.mahr.com/marcom (only for Mahr data cables and wireless systems with USB and RS-232 interface)
- **Digital height:** 10 mm
- **Data interface:** USB, Opto RS-232C, Digimatic
- **Energy supply:** Battery life approx. 3 years
- **Battery type:** CR 2032 (3V Lithium)
- **IP protection category:** IP 65
- **Package contains:** battery, instruction manual, case

TECHNICAL DATA

| Order no. | Type | Measuring range | Measuring range | Resolution | Measuring blades for outside measurements | Error limit | Standard | Weight |
|-----------|--------|-----------------|-----------------|---------------|---|-------------|------------------|--------|
| | | mm | inch | mm/inch | | mm | | kg |
| 4112704 | 18 EWR | 0–300 | 0–12" | 0.01 / .0005" | • | 0.03 | Factory standard | 0.45 |
| 4112712 | 18 EWR | 0–500 | 0–20" | 0.01 / .0005" | • | 0.04 | Factory standard | 1.10 |
| 4112714 | 18 EWR | 0–750 | 0–30" | 0.01 / .0005" | • | 0.05 | Factory standard | 1.35 |
| 4112716 | 18 EWR | 0–1000 | 0–40" | 0.01 / .0005" | • | 0.06 | Factory standard | 2.20 |
| 4112705 | 18 EWR | 0–300 | 0–12" | 0.01 / .0005" | | 0.03 | Factory standard | 0.44 |
| 4112713 | 18 EWR | 0–500 | 0–20" | 0.01 / .0005" | | 0.04 | Factory standard | 1.00 |
| 4112715 | 18 EWR | 0–750 | 0–30" | 0.01 / .0005" | | 0.05 | Factory standard | 1.28 |
| 4112717 | 18 EWR | 0–1000 | 0–40" | 0.01 / .0005" | | 0.06 | Factory standard | 2.10 |

| Order no. | a | b | c | d | e | f |
|-----------|------|-----|----|----|----|----|
| | mm | mm | mm | mm | mm | mm |
| 4112704 | 410 | 90 | 10 | 10 | 20 | 40 |
| 4112712 | 650 | 150 | 20 | 20 | 25 | 55 |
| 4112714 | 905 | 150 | 20 | 20 | 25 | 55 |
| 4112716 | 1165 | 150 | 20 | 20 | 30 | 60 |
| 4112705 | 410 | 90 | 10 | 10 | 20 | |
| 4112713 | 650 | 150 | 20 | 20 | 25 | |
| 4112715 | 905 | 150 | 20 | 20 | 25 | |
| 4112717 | 1165 | 150 | 20 | 20 | 30 | |

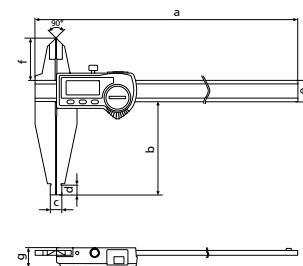

ACCESSORIES

| Order no. | Description | Type |
|-----------|---|---------|
| 4102230 | e-Stick receiver | e-Stick |
| 4102231 | 16 EWe Transmitter for e-Stick | 16 EWe |
| 4102357 | 16 EXu Data connection cable USB (2 m) | 16 EXu |
| 4102410 | Data connection cable RS232C (2 m) | 16 EXr |
| 4102915 | Interface adapter with data cable digimatic (2 m) | 16 EWd |



16 EWe



e-Stick

FUNCTIONS

- ON/OFF
- RESET (set display to zero)
- mm/inch
- HOLD (storage of measured values)
- PRESET (for entering a numerical value)

FEATURES

- To reduce the overall weight the slide and beam are made from aluminum and are coated with a hard anodized surface coating (1100 HV)
- High contrast digital display
- Locking screw above
- Rounded measuring blades for inside measurements
- Prism guideway for a more smooth and even movement
- Measuring surfaces made of steel
- Measuring blades for outside measurements
- Dirt wipers are integrated in the slide
- **Software:** MarCom Professional free download: www.mahr.com/marcom (only for Mahr data cables and wireless systems with USB and RS-232 interface)
- **Digital height:** 12 mm
- **Data interface:** none
- **Energy supply:** Battery life approx. 2 years
- **Battery type:** CR 2032 (3V Lithium)
- **IP protection category:** None
- **Package contains:** battery, instruction manual, case



TECHNICAL DATA

| Order no. | Type | Measuring range | Measuring range | Resolution | Measuring blades for outside measurements | Error limit | Standard | Weight |
|-----------|--------|-----------------|-----------------|---------------|---|-------------|------------------|--------|
| | | mm | inch | mm/inch | | mm | | kg |
| 4112621 | 18 ESA | 0–500 | 0–20" | 0.01 / .0005" | • | 0.05 | Factory standard | 1.40 |
| 4112622 | 18 ESA | 0–800 | 0–32" | 0.01 / .0005" | • | 0.07 | Factory standard | 1.60 |
| 4112623 | 18 ESA | 0–1000 | 0–40" | 0.01 / .0005" | • | 0.08 | Factory standard | 1.80 |

| Order no. | a | b | c | d | e | f | g | h | i |
|-----------|------|----|-----|------|----|----|------|----|----|
| | mm | mm | mm | mm | mm | mm | mm | mm | mm |
| 4112621 | 726 | 42 | 150 | 20.7 | 15 | 20 | 31.9 | 6 | 29 |
| 4112622 | 1026 | 42 | 150 | 20.7 | 15 | 20 | 31.9 | 6 | 29 |
| 4112623 | 1225 | 42 | 150 | 20.7 | 15 | 20 | 31.9 | 6 | 29 |

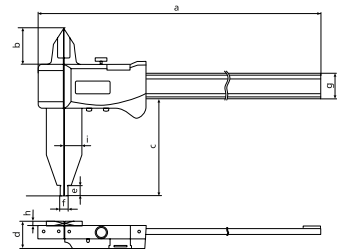

MarCal 18 NA

Workshop calipers

FEATURES

- To reduce the overall weight the slide and beam are made from aluminum and are coated with a hard anodized surface coating (1100 HV)
- Vernier and scale have a satin chrome finish for glare free reading
- Parallax-free reading
- Locking screw above
- Prism guideway for a more smooth and even movement
- Measuring surfaces made of steel
- Measuring blades for outside measurements
- Package contains: case



TECHNICAL DATA

| Order no. | Type | Measuring range | Vernier value | Measuring blades for outside measurements | Error limit | Standard | Weight |
|-----------|-------|-----------------|---------------|---|-------------|------------------|--------|
| | | mm | mm | | mm | | kg |
| 4112301 | 18 NA | 0–500 | 0.02 | • | 0.05 | Factory standard | 1.40 |
| 4112302 | 18 NA | 0–800 | 0.02 | • | 0.07 | Factory standard | 1.60 |
| 4112303 | 18 NA | 0–1000 | 0.02 | • | 0.08 | Factory standard | 1.75 |

| Order no. | a | b | c | d | e | f | g | h | i |
|-----------|------|----|-----|------|----|----|------|----|----|
| | mm | mm | mm | mm | mm | mm | mm | mm | mm |
| 4112301 | 726 | 42 | 150 | 20.7 | 15 | 20 | 31.9 | 6 | 29 |
| 4112302 | 1026 | 42 | 150 | 20.7 | 15 | 20 | 31.9 | 6 | 29 |
| 4112303 | 1226 | 42 | 150 | 20.7 | 15 | 20 | 31.9 | 6 | 29 |

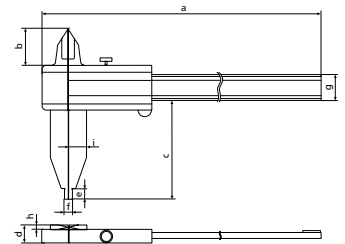

MarCal 16 EWri-V

Digital universal caliper



FUNCTIONS

- AUTO-ON / OFF
- ON/OFF
- DATA (data transmission via connection cable)
- HOLD (storage of measured values)
- PRESET (for entering a numerical value)
- RESET (set display to zero)
- mm/inch
- LOCK function (key lock)

FEATURES

- High contrast digital display
- Locking screw above
- Lapped guideway
- Measuring blade for inside measurements
- Slide and beam made of hardened stainless steel
- Step measuring function
- Immediate measurements due to the Reference System
- Raised guideway for the protection of the scale
- Excellent resistance against dust, coolants and lubricants
- Dirt wipers are integrated in the slide
- **Software:** MarCom Professional free download: www.mahr.com/marcom (only for Mahr data cables and wireless systems with USB and RS-232 interface)
- **Digital height:** 11 mm
- **Data interface:** Integrated Wireless
- **Energy supply:** Battery life approx. 3 years (approx. 0.5 in wireless mode)
- **Battery type:** CR 2032 (3V Lithium)
- **IP protection category:** IP 67
- **Package contains:** battery, instruction manual, case, setting gage for inside measurement 16 Eel, measuring force device 16 Ec, depth measuring bridge 16 Em, anvils for outside measurement 16 Eea 1–3, anvils for inside measurement 16Eei 1–3

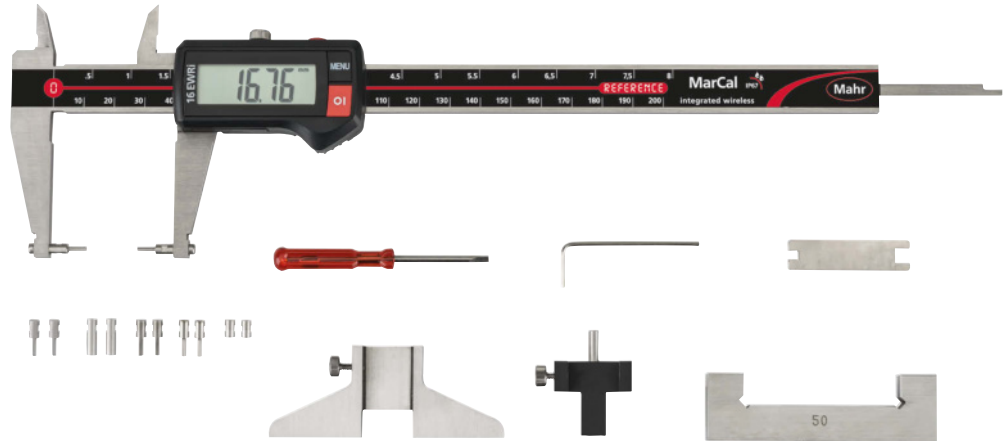

Applications:

- Can be used as standard calipers (four measuring directions) with standard accessories for measuring recesses, grooves, etc.
- Can be used with special accessories for measuring threads, bores and gears



TECHNICAL DATA

| Order no. | Type | Measuring range | Measuring range | Resolution | Error limit | Standard | Depth rod | Accessories |
|-----------|-----------|-----------------|-----------------|---------------|-------------|----------|-------------|-------------|
| | | mm | inch | mm/inch | mm | | | |
| 4118907 | 16 EWri-V | 0 – 200 | 0 – 8" | 0.01 / .0005" | 0.03 | DIN 862 | rectangular | • |

| Order no. | b | c | d | e |
|-----------|----|------|-----|----|
| | mm | mm | mm | mm |
| 4118907 | 48 | 16.5 | 285 | 16 |

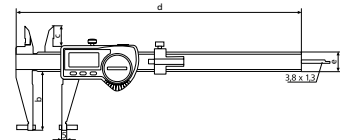

ACCESSORIES

| Order no. | Description | Quantity | unit | Type |
|-----------|--|----------|------|----------|
| 4102020 | Depth bridge (75 x 7 mm) | | | 16 Em |
| 4118810 | Anvil for outside measurement (3.5 x 12 mm) | Piece | | 16 Eea 1 |
| 4118811 | Anvil for outside measurement (1.5 x 6 mm) | Piece | | 16 Eea 2 |
| 4118812 | Anvil for outside measurement (3.5 x 6 mm) | Piece | | 16 Eea 3 |
| 4118813 | Anvil for inside measurement (3.5 x 6 mm) | Piece | | 16 Eei 1 |
| 4118814 | Anvil for inside measurement (1.5 x 6 mm) | Piece | | 16 Eei 2 |
| 4118815 | Anvil for inside measurement (3.5 x 6 mm) | Piece | | 16 Eei 3 |
| 4118816 | Anvil for inside measurement (4 x 2.5 mm) | Piece | | 16 Eei 4 |
| 4118817 | Setting gage for inside measurement (50 mm) | | | 16 Eel |
| 4118818 | Measuring force device | | | 16 Ec |
| 4879602 | Screws M2x8 | Piece | | |
| 4118819 | Mounting attachment for thread anvils 844 TG/844 Tr and ball anvils 844 Tk | | | 16 Eab |
| 4102220 | Receiver for instruments with Integrated Wireless | | | i-Stick |

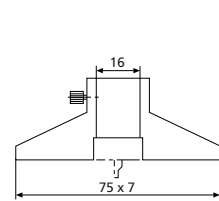

16 Em

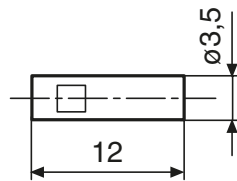

16 Eea 1

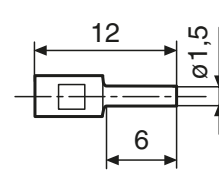

16 Eea 2

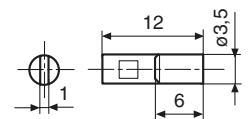

16 Eea 3

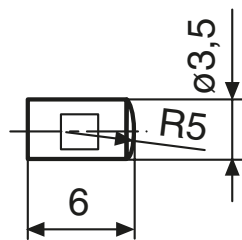

16 Eei 1

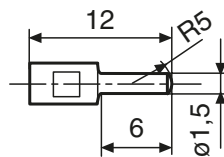

16 Eei 2

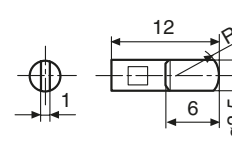

16 Eei 3

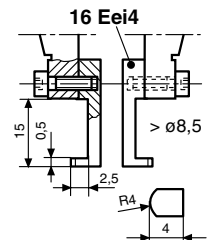

16 Eei 4

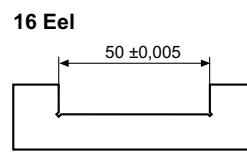

16 Eei

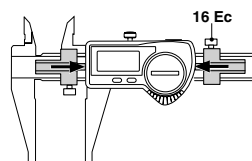

16 Ec

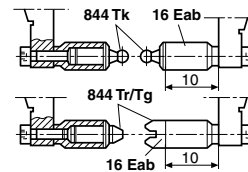

16 Eab



i-Stick

MarCal 16 EWR-V

Digital universal caliper



FUNCTIONS

- AUTO-ON / OFF
- DATA (data transmission via connection cable)
- ON/OFF
- PRESET (for entering a numerical value)
- RESET (set display to zero)
- mm/inch
- LOCK function (key lock)

FEATURES

- High contrast digital display
- Locking screw above
- Lapped guideway
- Measuring blade for inside measurements
- Slide and beam made of hardened stainless steel
- Step measuring function
- Immediate measurements due to the Reference System
- Raised guideway for the protection of the scale
- Excellent resistance against dust, coolants and lubricants
- Dirt wipers are integrated in the slide
- **Software:** MarCom Professional free download: www.mahr.com/marcom (only for Mahr data cables and wireless systems with USB and RS-232 interface)
- **Digital height:** 8.5 mm
- **Data interface:** USB, Opto RS-232C, Digimatic
- **Energy supply:** Battery life approx. 3 years
- **Battery type:** CR 2032 (3V Lithium)
- **IP protection category:** IP 67
- **Package contains:** battery, instruction manual, case, setting gage for inside measurement 16 Eel, measuring force device 16 Ec, depth measuring bridge 16 Em, anvils for outside measurement 16 Eea 1-3, anvils for inside measurement 16Eei 1-3, 4118808 without measuring anvils, adjustment bridge and measuring force equipment

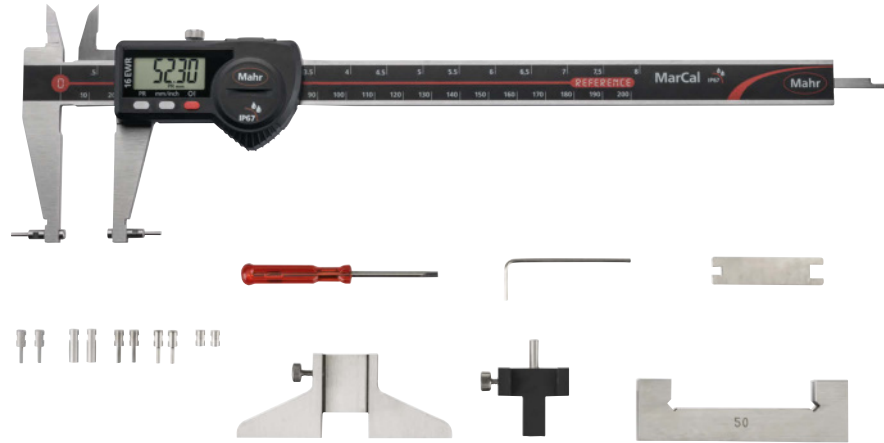

Applications:

- Can be used as a standard caliper (four types of measurements) with standard accessories to measure recesses, grooves, etc.
- Can be used with additional accessories to measure threads, bores and serration

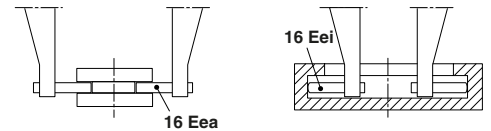

TECHNICAL DATA

| Order no. | Type | Measuring range mm | Measuring range inch | Resolution mm/inch | Error limit mm | Standard | Depth rod | Accessories |
|-----------|----------|-----------------------|-------------------------|-----------------------|-------------------|----------|-------------|-------------|
| 4118807 | 16 EWR-V | 0-200 | 0-8" | 0.01 / .0005" | 0.03 | DIN 862 | rectangular | • |

| Order no. | b | c | d | e |
|-----------|----|------|-----|----|
| 4118807 | 48 | 16.5 | 285 | 16 |

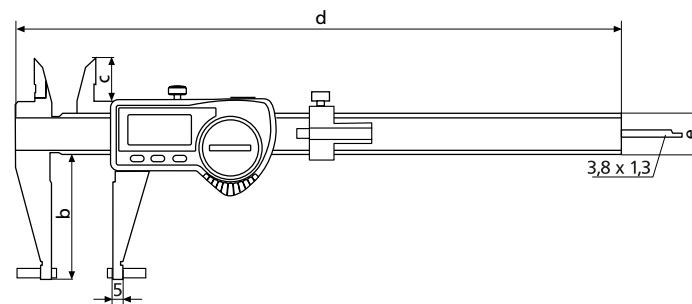

ACCESSORIES

| Order no. | Description | Quantity | unit | Type |
|-----------|--|----------|------|----------|
| 4118810 | Anvil for outside measurement (3.5 x 12 mm) | Piece | | 16 Eea 1 |
| 4118811 | Anvil for outside measurement (1.5 x 6 mm) | Piece | | 16 Eea 2 |
| 4118812 | Anvil for outside measurement (3.5 x 6 mm) | Piece | | 16 Eea 3 |
| 4118813 | Anvil for inside measurement (3.5 x 6 mm) | Piece | | 16 Eei 1 |
| 4118814 | Anvil for inside measurement (1.5 x 6 mm) | Piece | | 16 Eei 2 |
| 4118815 | Anvil for inside measurement (3.5 x 6 mm) | Piece | | 16 Eei 3 |
| 4118816 | Anvil for inside measurement (4 x 2.5 mm) | Piece | | 16 Eei 4 |
| 4118817 | Setting gage for inside measurement (50 mm) | | | 16 Eel |
| 4118818 | Measuring force device | | | 16 Ec |
| 4879602 | Screws M2x8 | Piece | | |
| 4118819 | Mounting attachment for thread anvils 844 TG/844 Tr and ball anvils 844 Tk | | | 16 Eab |
| 4102020 | Depth bridge (75 x 7 mm) | | | 16 Em |
| 4102357 | 16 EXu Data connection cable USB (2 m) | | | 16 EXu |
| 4102915 | Interface adapter with data cable Digimatic | | | 16 EWd |
| 4102410 | Data connection cable RS232C (2 m) | | | 16 EXr |

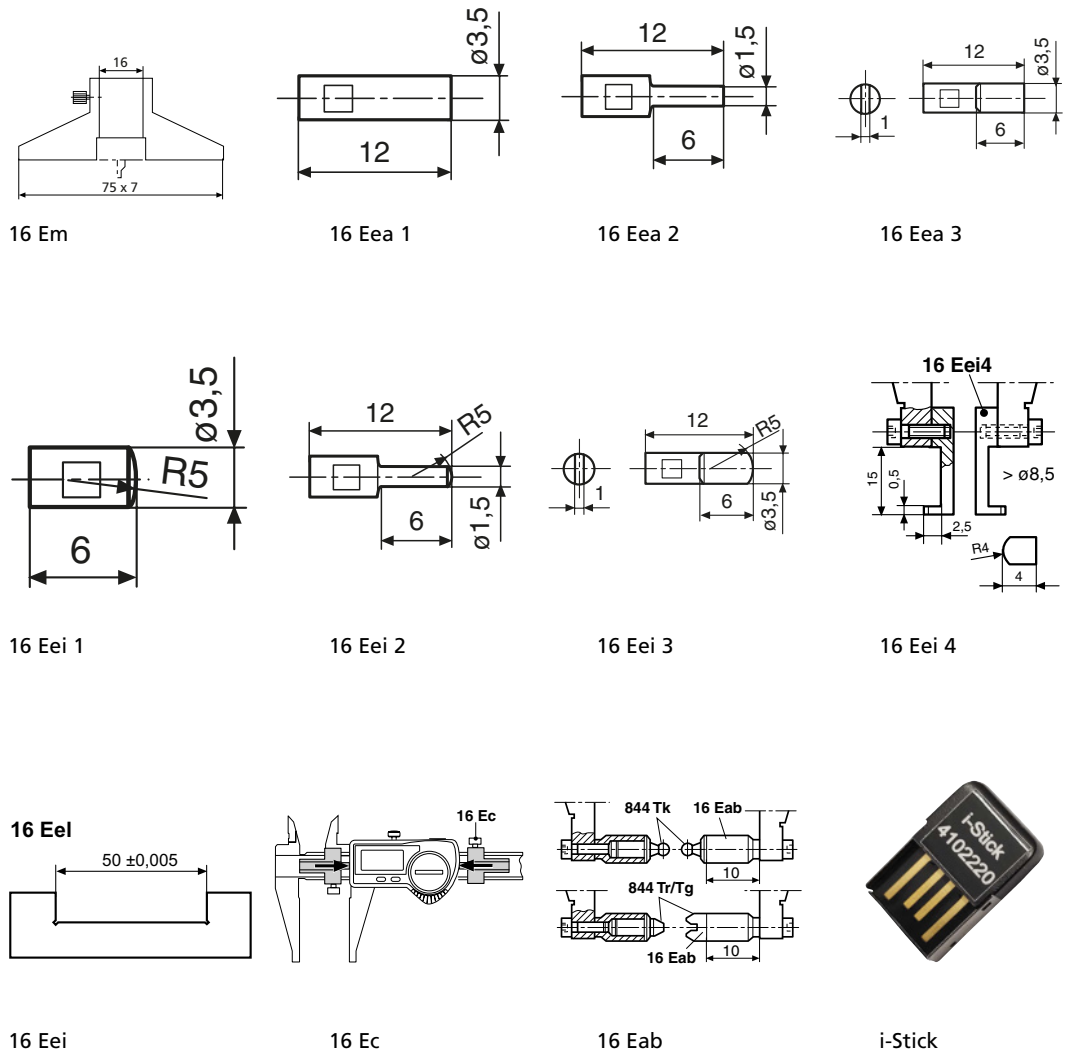

MarCal 18 EWR-V

Digital universal caliper



FUNCTIONS

- ON/OFF
- AUTO-ON / OFF
- RESET (set display to zero)
- PRESET (for entering a numerical value)
- mm/inch
- LOCK function (key lock)
- DATA (data transmission via connection cable)

FEATURES

- High contrast digital display
- Locking screw above
- Immediate measurements due to the Reference System
- Excellent resistance against dust, coolants and lubricants
- Dirt wipers are integrated in the slide
- Slide and beam made of hardened stainless steel
- Measuring faces for outside measurement
- Thread M2.5 measuring jaws to accommodate measuring anvils for internal and external measurements
- **Software:** MarCom Professional free download: www.mahr.com/marcom (only for Mahr data cables and wireless systems with USB and RS-232 interface)
- **Digital height:** 10 mm
- **Data interface:** USB, Opto RS-232C, Digimatic
- **Energy supply:** Battery life approx. 3 years
- **Battery type:** CR 2032 (3V Lithium)
- **IP protection category:** IP 65
- **Package contains:** battery, case, instruction manual, anvils

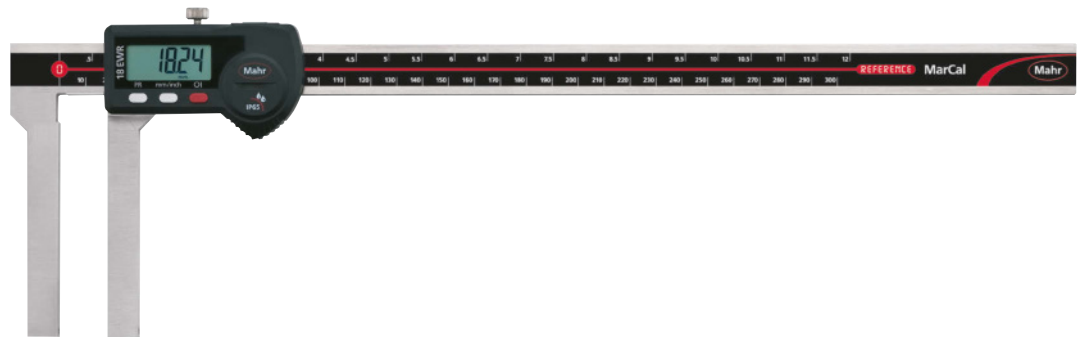

Applications:

- For inner and outer measurements of recesses, grooves, etc.
- Individual adjustment by means of measuring anvils with M2.5 thread

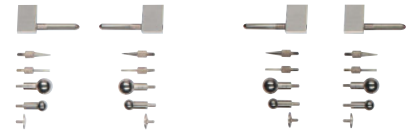

TECHNICAL DATA

| Order no. | Type | Measuring range mm | Measuring range inch | Resolution mm/inch | Error limit mm | Standard |
|-----------|----------|--------------------|----------------------|--------------------|----------------|------------------|
| 4112722 | 18 EWR-V | 0 – 300 | 0 – 12" | 0.01 / .0005" | 0.06 | Factory standard |
| 4112723 | 18 EWR-V | 0 – 500 | 0 – 20" | 0.01 / .0005" | 0.08 | Factory standard |

| Order no. | a | b | c | d | e |
|-----------|-----|-----|----|------|----|
| | mm | mm | mm | mm | mm |
| 4112722 | 410 | 90 | 12 | 75.5 | 20 |
| 4112723 | 680 | 100 | 16 | 81 | 25 |

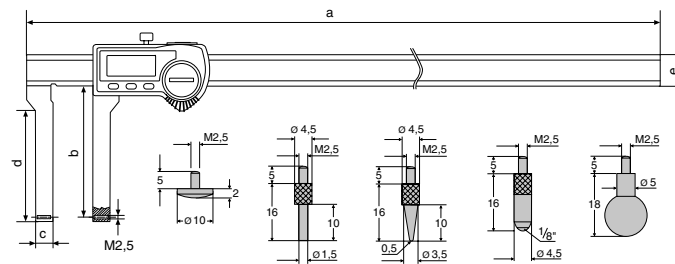

ACCESSORIES

| Order no. | Description | Quantity unit | Type |
|-----------|--|---------------|---------|
| 4102230 | e-Stick Receiver | | e-Stick |
| 4102231 | 16 EWe transmitter for e-Stick | | 16 EWe |
| 4102357 | 16 EXu data connection cable USB (2 m) | | 16 EXu |
| 4102410 | Data connection cable RS232C (2 m) | | 16 EXr |
| 4102915 | Interface Adapter with data cable digimatic (2 m) | | 16 EWd |
| 4112050 | Replacement measuring anvil: Spherical plate \varnothing 10.0 mm | Piece | |
| 4112051 | Replacement measuring anvil: Cylindrical stylus \varnothing 1.5 mm x 10 mm | Piece | |
| 4112052 | Replacement measuring anvil: Tip, radius 0.5 mm x 10 mm | Piece | |
| 4112053 | Replacement measuring anvil: Sphere \varnothing 1/8" length 16 mm | Piece | |
| 4112054 | Replacement measuring anvil: Ball \varnothing 7.0 mm | Piece | |
| 4112055 | Replacement measuring anvil: Sphere \varnothing 10.0 mm | Piece | |

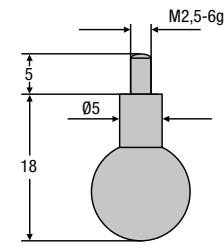
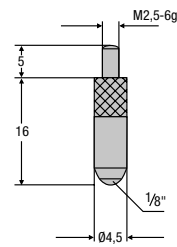
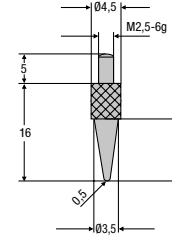
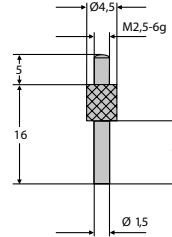
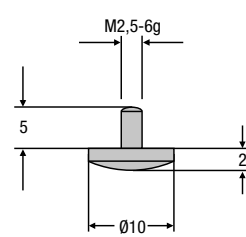

16 EWe



e-Stick

MarCal 16 EWri-C / 16 EWR-C

Digital special calipers

FUNCTIONS

16 EWri-C:

- ON/OFF
- AUTO-ON / OFF
- mm/inch
- LOCK function (key lock)
- RESET (set display to zero)
- PRESET (for entering a numerical value)
- DATA (data transmission)
- HOLD (storage of measured values)

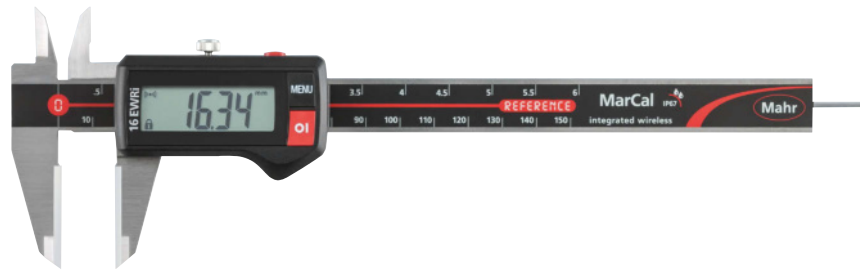

16 EWri-C

16 EWR-C:

- ON/OFF
- AUTO-ON / OFF
- mm/inch
- LOCK function (key lock)
- RESET (set display to zero)
- DATA (data transmission via connection cable)
- High contrast digital display
- Locking screw above
- Lapped guideway
- Measuring blade for inside measurements
- Slide and beam made of hardened stainless steel
- Step measuring function
- Immediate measurements due to the Reference System
- Raised guideway for the protection of the scale
- Excellent resistance against dust, coolants and lubricants
- Dirt wipers are integrated in the slide

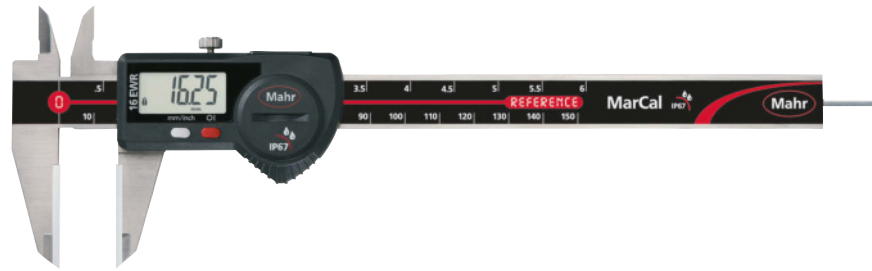

16 EWR-C

Application:

- Outer measuring surfaces made of ceramic, for measuring hard materials

TECHNICAL DATA

| Order no. | Type | Measuring range | Measuring range | Resolution | Error limit | Standard | Depth rod |
|-----------|-----------|-----------------|-----------------|---------------|-------------|----------|-----------|
| | | mm | inch | mm/inch | mm | | |
| 4103372 | 16 EWri-C | 0 - 150 | 0 - 6" | 0.01 / .0005" | 0.03 | DIN 862 | round |
| 4103072 | 16 EWR-C | 0 - 150 | 0 - 6" | 0.01 / .0005" | 0.03 | DIN 862 | round |

| Order no. | a | b | c | d | e |
|-----------|----|----|----|-----|----|
| | mm | mm | mm | mm | mm |
| 4103372 | 10 | 40 | 16 | 235 | 16 |
| 4103072 | 10 | 40 | 16 | 235 | 16 |

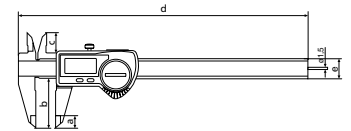

FEATURES 16 EWri-C:

- **Software:** MarCom Professional free download: www.mahr.com/marcom (only for Mahr data cables and wireless systems with USB and RS-232 interface)
- **Digital height:** 11 mm
- **Data interface:** Integrated Wireless
- **Energy supply:** Battery life approx. 3 years (approx. 0.5 in wireless mode)
- **Battery type:** CR 2032 (3V Lithium)
- **IP protection category:** IP 67
- **Package contains:** battery, instruction manual, case

FEATURES 16 EWR-C:

- **Digital height:** 8.5 mm
- **Data interface:** USB, Opto RS-232C, Digimatic
- **Energy supply:** Battery life approx. 3 years

ACCESSORIES

| Order no. | For measuring instrument | Description | Type |
|-----------|--------------------------|---|---------|
| 4102220 | 16 EWri-C | Receiver for instruments with Integrated Wireless | i-Stick |
| 4102357 | 16 EWR-C | 16 EXu data connection cable USB (2 m) | 16 EXu |
| 4102410 | 16 EWR-C | Data connection cable RS232C (2 m) | 16 EXr |
| 4102915 | 16 EWR-C | Interface adapter with data cable Digimatic (2 m) | 16 EWd |



i-Stick

MarCal 16 EWri-H / 16 EWR-H

Digital special calipers

FUNCTIONS

16 EWri-H:

- ON/OFF
- AUTO-ON / OFF
- mm/inch
- LOCK function (key lock)
- RESET (set display to zero)
- PRESET (for entering a numerical value)
- DATA (data transmission)
- HOLD (storage of measured values)



16 EWri-H



16 EWR-H:

- ON/OFF
- AUTO-ON / OFF
- mm/inch
- LOCK function (key lock)
- RESET (set display to zero)
- DATA (data transmission via connection cable)
- High contrast digital display
- Locking screw above
- Lapped guideway
- Measuring blade for inside measurements
- Slide and beam made of hardened stainless steel
- Step measuring function
- Immediate measurements due to the Reference System
- Raised guideway for the protection of the scale
- Excellent resistance against dust, coolants and lubricants
- Dirt wipers are integrated in the slide

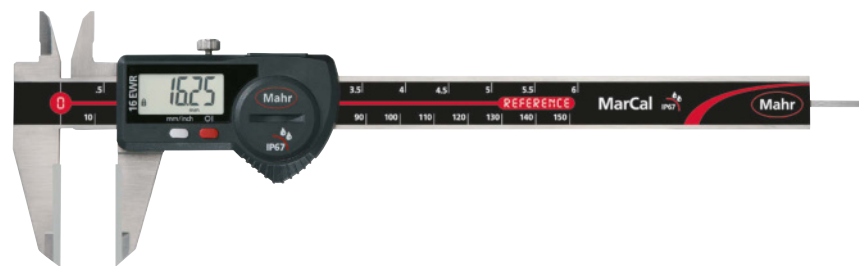

16 EWR-H



Application:

- Outer measuring surfaces made of carbide, for measuring hard materials

TECHNICAL DATA

| Order no. | Type | Measuring range | Measuring range | Resolution | Error limit | Standard | Depth rod |
|-----------|-----------|-----------------|-----------------|---------------|-------------|----------|-----------|
| | | mm | inch | mm/inch | mm | | |
| 4103373 | 16 EWri-H | 0–150 | 0–6" | 0.01 / .0005" | 0.03 | DIN 862 | round |
| 4103073 | 16 EWR-H | 0–150 | 0–6" | 0.01 / .0005" | 0.03 | DIN 862 | round |

| Order no. | a | b | c | d | e |
|-----------|----|----|----|-----|----|
| | mm | mm | mm | mm | mm |
| 4103373 | 10 | 40 | 16 | 235 | 16 |
| 4103073 | 10 | 40 | 16 | 235 | 16 |

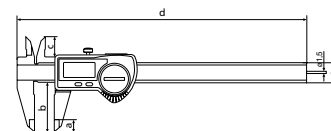

FEATURES 16 EWri-H:

- **Software:** MarCom Professional free download: www.mahr.com/marcom (only for Mahr data cables and wireless systems with USB and RS-232 interface)
- **Digital height:** 11 mm
- **Data interface:** Integrated Wireless
- **Energy supply:** Battery life approx. 3 years (approx. 0.5 in wireless mode)
- **Battery type:** CR 2032 (3V Lithium)
- **IP protection category:** IP 67
- **Package contains:** battery, instruction manual, case

FEATURES 16 EWR-H:

- **Digital height:** 8.5 mm
- **Data interface:** USB, Opto RS-232C, Digimatic
- **Energy supply:** Battery life approx. 3 years

ACCESSORIES

| Order no. | For measuring instrument | Description | Type |
|-----------|--------------------------|---|---------|
| 4102220 | 16 EWri-H | Receiver for instruments with Integrated Wireless | i-Stick |
| 4102357 | 16 EWR-H | 16 EXu data connection cable USB (2 m) | 16 EXu |
| 4102410 | 16 EWR-H | Data connection cable RS232C (2 m) | 16 EXr |
| 4102915 | 16 EWR-H | Interface adapter with data cable Digimatic (2 m) | 16 EWd |



i-Stick

MarCal 16 EWri-AR / 16 EWR-AR

Digital special calipers

FUNCTIONS

16 EWri-AR:

- ON/OFF
- AUTO-ON / OFF
- mm/inch
- LOCK function (key lock)
- RESET (set display to zero)
- PRESET (for entering a numerical value)
- DATA (data transmission)
- HOLD (storage of measured values)

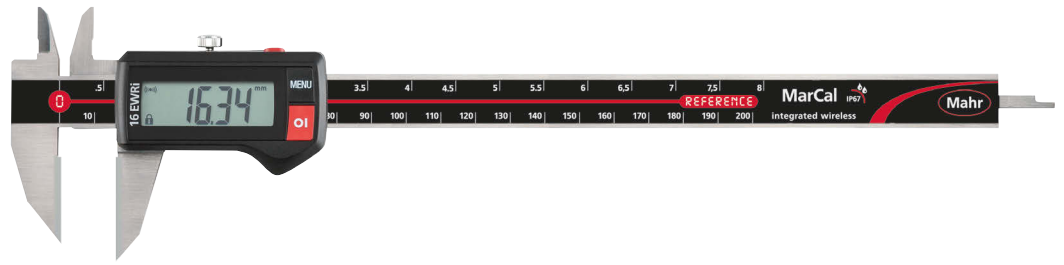

16 EWri-AR



16 EWR-AR:

- ON/OFF
- AUTO-ON / OFF
- mm/inch
- LOCK function (key lock)
- RESET (set display to zero)
- DATA (data transmission via connection cable)
- High contrast digital display
- Locking screw above
- Lapped guideway
- Measuring blade for inside measurements
- Slide and beam made of hardened stainless steel
- Step measuring function
- Immediate measurements due to the Reference System
- Raised guideway for the protection of the scale
- Excellent resistance against dust, coolants and lubricants
- Dirt wipers are integrated in the slide

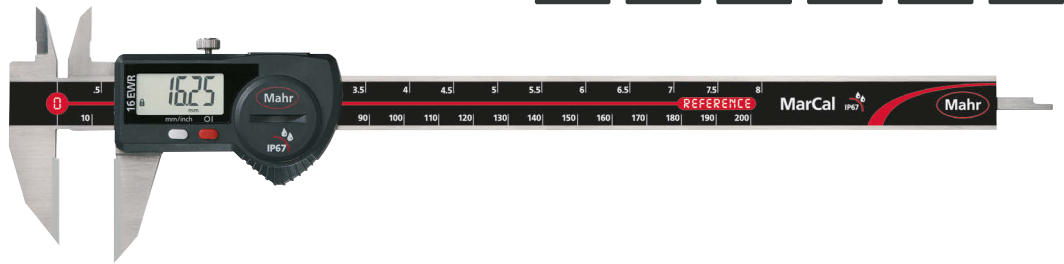

16 EWR-AR



Applications:

- Outer measuring surfaces made of carbide
- For marking out workpieces

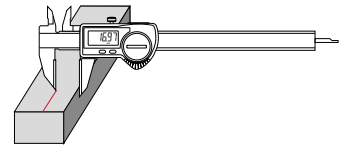

TECHNICAL DATA

| Order no. | Type | Measuring range | Measuring range | Resolution | Error limit | Standard | Depth rod |
|-----------|------------|-----------------|-----------------|---------------|-------------|------------------|-------------|
| | | mm | inch | mm/inch | mm | | |
| 4103382 | 16 EWri-AR | 0–200 | 0–8" | 0.01 / .0005" | 0.03 | Factory standard | rectangular |
| 4103082 | 16 EWR-AR | 0–200 | 0–8" | 0.01 / .0005" | 0.03 | Factory standard | rectangular |

| Order no. | c | d | e |
|-----------|------|-----|----|
| 4103382 | 16.5 | 285 | 16 |
| 4103082 | 16.5 | 285 | 16 |

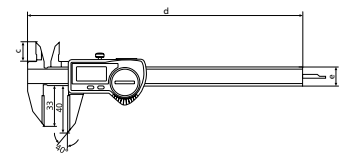

FEATURES 16 EWri-AR:

- **Software:** MarCom Professional free download: www.mahr.com/marcom (only for Mahr data cables and wireless systems with USB and RS-232 interface)
- **Digital height:** 11 mm
- **Data interface:** Integrated Wireless
- **Energy supply:** Battery life approx. 3 years (approx. 0.5 in wireless mode)
- **Battery type:** CR 2032 (3V Lithium)
- **IP protection category:** IP 67
- **Package contains:** battery, instruction manual, case

FEATURES 16 EWR-AR:

- **Digital height:** 8.5 mm
- **Data interface:** USB, Opto RS-232C, Digimatic
- **Energy supply:** Battery life approx. 3 years

ACCESSORIES

| Order no. | For measuring instrument | Description | Type |
|-----------|--------------------------|---|---------|
| 4102220 | 16 EWri-AR | Receiver for instruments with Integrated Wireless | i-Stick |
| 4102357 | 16 EWR-AR | 16 EXu data connection cable USB (2 m) | 16 EXu |
| 4102410 | 16 EWR-AR | Data connection cable RS232C (2 m) | 16 EXr |
| 4102915 | 16 EWR-AR | Interface adapter with data cable Digimatic (2 m) | 16 EWd |



i-Stick

MarCal 16 EWri-NA / 16 EWR-NA

Digital special calipers

FUNCTIONS

16 EWri-NA:

- ON/OFF
- AUTO-ON / OFF
- mm/inch
- LOCK function (key lock)
- RESET (set display to zero)
- PRESET (for entering a numerical value)
- DATA (data transmission)
- HOLD (storage of measured values)

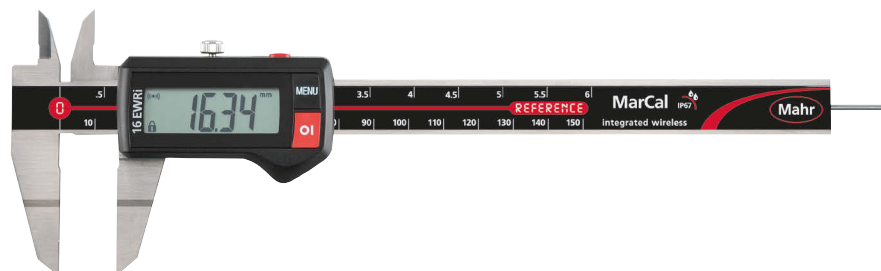

16 EWri-NA



16 EWR-NA:

- ON/OFF
- AUTO-ON / OFF
- mm/inch
- LOCK function (key lock)
- RESET (set display to zero)
- DATA (data transmission via connection cable)
- High contrast digital display
- Locking screw above
- Lapped guideway
- Measuring blade for inside measurements
- Slide and beam made of hardened stainless steel
- Step measuring function
- Immediate measurements due to the Reference System
- Raised guideway for the protection of the scale
- Excellent resistance against dust, coolants and lubricants
- Dirt wipers are integrated in the slide

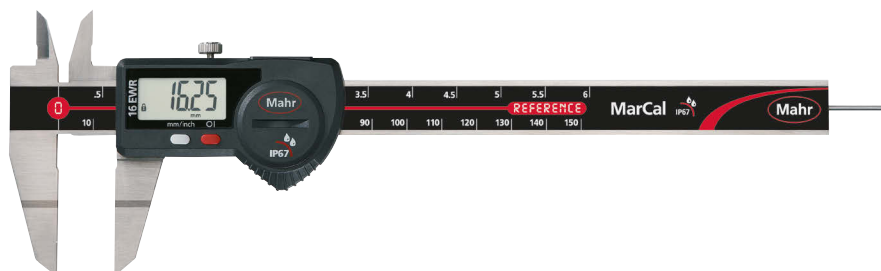

16 EWR-NA

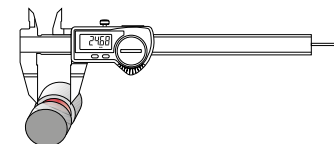

Application:

For measuring keyseats

TECHNICAL DATA

| Order no. | Type | Measuring range | Measuring range | Resolution | Error limit | Standard | Depth Rod |
|-----------|------------|-----------------|-----------------|---------------|-------------|------------------|-----------|
| | | mm | inch | mm/inch | mm | | |
| 4103374 | 16 EWri-NA | 0 – 150 | 0 – 6" | 0.01 / .0005" | 0.03 | Factory standard | round |
| 4103074 | 16 EWR-NA | 0 – 150 | 0 – 6" | 0.01 / .0005" | 0.03 | Factory standard | round |

| Order no. | a | b | c | d | e |
|-----------|----|----|------|-----|----|
| | mm | mm | mm | mm | mm |
| 4103374 | 20 | 40 | 16.5 | 235 | 16 |
| 4103074 | 20 | 40 | 16.5 | 235 | 16 |

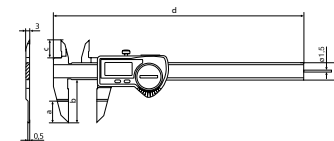

FEATURES 16 EWri-NA:

- **Software:** MarCom Professional free download: www.mahr.com/marcom (only for Mahr data cables and wireless systems with USB and RS-232 interface)
- **Digital height:** 11 mm
- **Data interface:** Integrated Wireless
- **Energy supply:** Battery life approx. 3 years (approx. 0.5 in wireless mode)
- **Battery type:** CR 2032 (3V Lithium)
- **IP protection category:** IP 67
- **Package contains:** battery, instruction manual, case

FEATURES 16 EWR-NA:

- **Digital height:** 8.5 mm
- **Data interface:** USB, Opto RS-232C, Digimatic
- **Energy supply:** Battery life approx. 3 years

ACCESSORIES

| Order no. | For measuring instrument | Description | Type |
|-----------|--------------------------|---|---------|
| 4102220 | 16 EWri-NA | Receiver for instruments with Integrated Wireless | i-Stick |
| 4102357 | 16 EWR-NA | 16 EXu data connection cable USB (2 m) | 16 EXu |
| 4102410 | 16 EWR-NA | Data connection cable RS232C (2 m) | 16 EXr |
| 4102915 | 16 EWR-NA | Interface adapter with data cable Digimatic (2 m) | 16 EWd |



i-Stick

MarCal 16 EWri-S / 16 EWR-S

Digital special calipers

FUNCTIONS

16 EWri-S:

- ON/OFF
- AUTO-ON / OFF
- mm/inch
- LOCK function (key lock)
- RESET (set display to zero)
- PRESET (for entering a numerical value)
- DATA (data transmission)
- HOLD (storage of measured values)

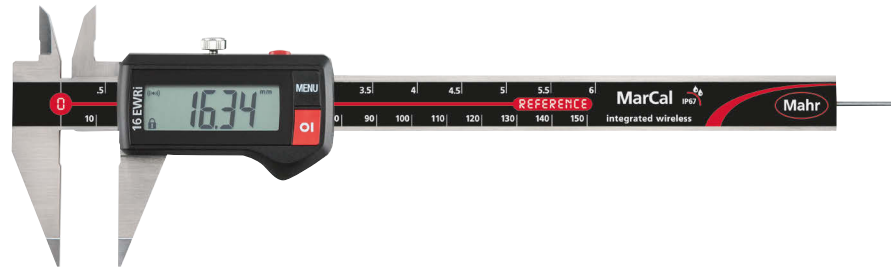

16 EWri-S

16 EWR-S:

- ON/OFF
- AUTO-ON / OFF
- mm/inch
- LOCK function (key lock)
- RESET (set display to zero)
- DATA (data transmission via connection cable)
- High contrast digital display
- Locking screw above
- Lapped guideway
- Measuring blade for inside measurements
- Slide and beam made of hardened stainless steel
- Step measuring function
- Immediate measurements due to the Reference System
- Raised guideway for the protection of the scale
- Excellent resistance against dust, coolants and lubricants
- Dirt wipers are integrated in the slide

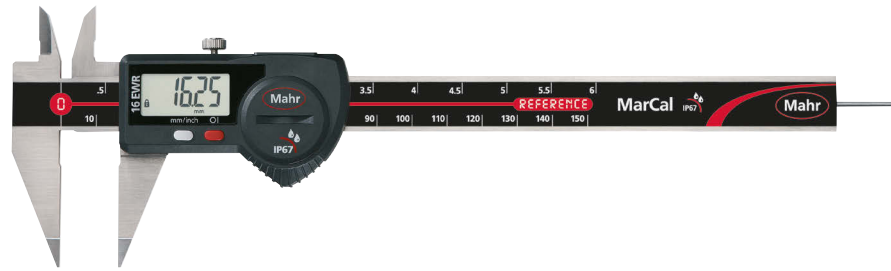

16 EWR-S

Application:

- With pointed jaws e.g. for measuring distances between grooves

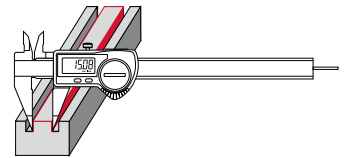

TECHNICAL DATA

| Order no. | Type | Measuring range | Measuring range | Resolution | Error limit | Standard | Depth Rod |
|-----------|-----------|-----------------|-----------------|---------------|-------------|------------------|-----------|
| | | mm | inch | mm/inch | mm | | |
| 4103375 | 16 EWri-S | 0 – 150 | 0 – 6" | 0.01 / .0005" | 0.03 | Factory standard | round |
| 4103075 | 16 EWR-S | 0 – 150 | 0 – 6" | 0.01 / .0005" | 0.03 | Factory standard | round |

| Order no. | a | b | c | d | e |
|-----------|----|----|------|-----|----|
| | mm | mm | mm | mm | mm |
| 4103375 | 10 | 40 | 16.5 | 235 | 16 |
| 4103075 | 10 | 40 | 16.5 | 235 | 16 |

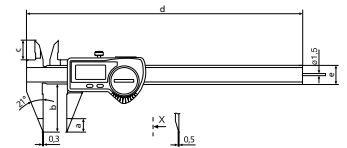

FEATURES 16 EWri-S:

- **Software:** MarCom Professional free download: www.mahr.com/marcom (only for Mahr data cables and wireless systems with USB and RS-232 interface)
- **Digital height:** 11 mm
- **Data interface:** Integrated Wireless
- **Energy supply:** Battery life approx. 3 years (approx. 0.5 in wireless mode)
- **Battery type:** CR 2032 (3V Lithium)
- **IP protection category:** IP 67
- **Package contains:** battery, instruction manual, case

FEATURES 16 EWR-S:

- **Digital height:** 8.5 mm
- **Data interface:** USB, Opto RS-232C, Digimatic
- **Energy supply:** Battery life approx. 3 years

ACCESSORIES

| Order no. | For measuring instrument | Description | Type |
|-----------|--------------------------|---|---------|
| 4102220 | 16 EWri-S | Receiver for instruments with Integrated Wireless | i-Stick |
| 4102357 | 16 EWR-S | 16 EXu data connection cable USB (2 m) | 16 EXu |
| 4102410 | 16 EWR-S | Data connection cable RS232C (2 m) | 16 EXr |
| 4102915 | 16 EWR-S | Interface adapter with data cable Digimatic (2 m) | 16 EWd |



i-Stick

MarCal 16 EWri-SM / 16 EWR-SM

Digital special calipers

FUNCTIONS

16 EWri-SM:

- ON/OFF
- AUTO-ON / OFF
- mm/inch
- LOCK function (key lock)
- RESET (set display to zero)
- PRESET (for entering a numerical value)
- DATA (data transmission)
- HOLD (storage of measured values)

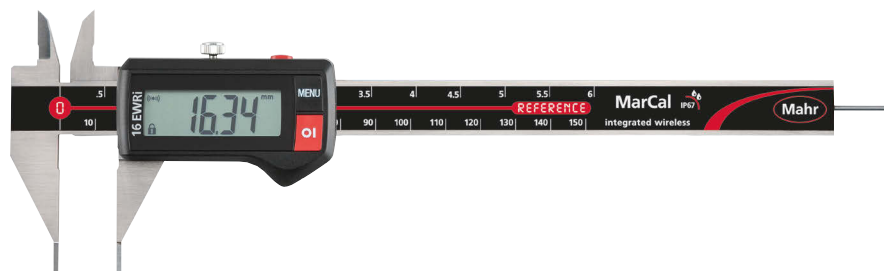

16 EWri-SM



16 EWR-SM:

- ON/OFF
- AUTO-ON / OFF
- mm/inch
- LOCK function (key lock)
- RESET (set display to zero)
- DATA (data transmission via connection cable)
- High contrast digital display
- Locking screw above
- Lapped guideway
- Measuring blade for inside measurements
- Slide and beam made of hardened stainless steel
- Step measuring function
- Immediate measurements due to the Reference System
- Raised guideway for the protection of the scale
- Excellent resistance against dust, coolants and lubricants
- Dirt wipers are integrated in the slide

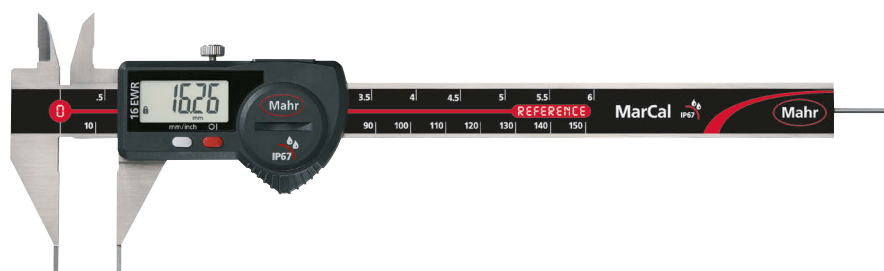

16 EWR-SM



Application:

- With pointed jaws e.g. for measuring distances between grooves

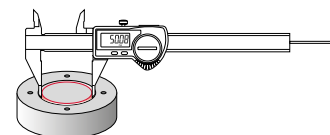

TECHNICAL DATA

| Order no. | Type | Measuring range | Measuring range | Resolution | Error limit | Standard | Depth rod |
|-----------|------------|-----------------|-----------------|---------------|-------------|------------------|-----------|
| | | mm | inch | mm/inch | mm | | |
| 4103376 | 16 EWri-SM | 0 – 150 | 0 – 6" | 0.01 / .0005" | 0.03 | Factory standard | round |
| 4103076 | 16 EWR-SM | 0 – 150 | 0 – 6" | 0.01 / .0005" | 0.03 | Factory standard | round |

| Order no. | a | b | c | d | e |
|-----------|----|----|------|-----|----|
| | mm | mm | mm | mm | mm |
| 4103376 | 10 | 40 | 16.5 | 235 | 16 |
| 4103076 | 10 | 40 | 16.5 | 235 | 16 |

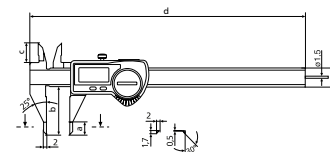

FEATURES 16 EWri-SM:

- **Software:** MarCom Professional free download: www.mahr.com/marcom (only for Mahr data cables and wireless systems with USB and RS-232 interface)
- **Digital height:** 11 mm
- **Data interface:** Integrated Wireless
- **Energy supply:** Battery life approx. 3 years (approx. 0.5 in wireless mode)
- **Battery type:** CR 2032 (3V Lithium)
- **IP protection category:** IP 67
- **Package contains:** battery, instruction manual, case

FEATURES 16 EWR-SM:

- **Digital height:** 8.5 mm
- **Data interface:** USB, Opto RS-232C, Digimatic
- **Energy supply:** Battery life approx. 3 years

ACCESSORIES

| Order no. | For measuring instrument | Description | Type |
|-----------|--------------------------|---|---------|
| 4102220 | 16 EWri-SM | Receiver for instruments with Integrated Wireless | i-Stick |
| 4102357 | 16 EWR-SM | 16 EXu data connection cable USB (2 m) | 16 EXu |
| 4102410 | 16 EWR-SM | Data connection cable RS232C (2 m) | 16 EXr |
| 4102915 | 16 EWR-SM | Interface adapter with data cable Digimatic (2 m) | 16 EWd |



i-Stick

MarCal 16 EWri-VS / 16 EWR-VS

Digital special calipers

FUNCTIONS

16 EWri-VS:

- ON/OFF
- AUTO-ON / OFF
- mm/inch
- LOCK function (key lock)
- RESET (set display to zero)
- PRESET (for entering a numerical value)
- DATA (data transmission)
- HOLD (storage of measured values)



16 EWR-VS:

- ON/OFF
- AUTO-ON / OFF
- mm/inch
- LOCK function (key lock)
- RESET (set display to zero)
- DATA (data transmission via connection cable)
- High contrast digital display
- Locking screw above
- Lapped guideway
- Measuring blade for inside measurements
- Slide and beam made of hardened stainless steel
- Immediate measurements due to the Reference System
- Raised guideway for the protection of the scale
- Excellent resistance against dust, coolants and lubricants
- Dirt wipers are integrated in the slide

16 EWri-VS



16 EWR-VS

Application:

- With moving jaws for measuring stepped workpieces

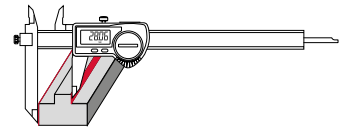

FEATURES 16 EWri-VS:

- **Software:** MarCom Professional free download: www.mahr.com/marcom (only for Mahr data cables and wireless systems with USB and RS-232 interface)
- **Digital height:** 11 mm
- **Data interface:** Integrated Wireless
- **Energy supply:** Battery life approx. 3 years (approx. 0.5 in wireless mode)
- **Battery type:** CR 2032 (3V Lithium)
- **IP protection category:** IP 67
- **Package contains:** battery, instruction manual, case

TECHNICAL DATA

| Order no. | Type | Measuring range | Measuring range | Resolution | Error limit | Standard | Depth Rod |
|-----------|------------|-----------------|-----------------|---------------|-------------|------------------|-------------|
| | | mm | inch | mm/inch | mm | | |
| 4103383 | 16 EWri-VS | 0-200 | 0-8" | 0.01 / .0005" | 0.04 | Factory standard | rectangular |
| 4103083 | 16 EWR-VS | 0-200 | 0-8" | 0.01 / .0005" | 0.04 | Factory standard | rectangular |

| Order no. | a | c | d | e |
|-----------|----|----|-----|----|
| | mm | mm | mm | mm |
| 4103383 | 14 | 18 | 278 | 16 |
| 4103083 | 14 | 18 | 278 | 16 |

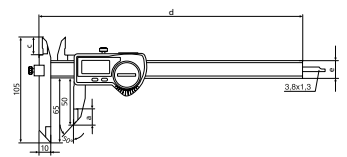

FEATURES 16 EWR-VS:

- **Digital height:** 8.5 mm
- **Data interface:** USB, Opto RS-232C, Digimatic
- **Energy supply:** Battery life approx. 3 years

ACCESSORIES

| Order no. | For measuring instrument | Description | Type |
|-----------|--------------------------|---|---------|
| 4102220 | 16 EWri-VS | Receiver for instruments with Integrated Wireless | i-Stick |
| 4102357 | 16 EWR-VS | 16 EXu data connection cable USB (2 m) | 16 EXu |
| 4102410 | 16 EWR-VS | Data connection cable RS232C (2 m) | 16 EXr |
| 4102915 | 16 EWR-VS | Interface adapter with data cable Digimatic (2 m) | 16 EWd |



i-Stick

MarCal 16 EWri-BA / 16 EWR-BA

Digital special calipers

FUNCTIONS

16 EWri-BA:

- ON/OFF
- AUTO-ON / OFF
- mm/inch
- LOCK function (key lock)
- RESET (set display to zero)
- PRESET (for entering a numerical value)
- DATA (data transmission)
- HOLD (storage of measured values)



16 EWri-BA

16 EWR-BA:

- ON/OFF
- AUTO-ON / OFF
- mm/inch
- LOCK function (key lock)
- RESET (set display to zero)
- PRESET (for entering a numerical value)
- DATA (data transmission via connection cable)
- High contrast digital display
- Locking screw above
- Lapped guideway
- Slide and beam made of hardened stainless steel
- Immediate measurements due to the Reference System
- Raised guideway for the protection of the scale
- Excellent resistance against dust, coolants and lubricants
- Dirt wipers are integrated in the slide



16 EWR-BA

Application:

- For measuring the distance between bores

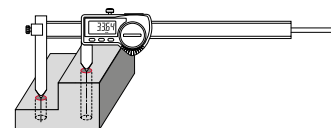

TECHNICAL DATA

FEATURES 16 EWri-BA:

- **Software:** MarCom Professional free download: www.mahr.com/marcom (only for Mahr data cables and wireless systems with USB and RS-232 interface)
- **Digital height:** 11 mm
- **Data interface:** Integrated Wireless
- **Energy supply:** Battery life approx. 3 years (approx. 0.5 in wireless mode)
- **Battery type:** CR 2032 (3V Lithium)
- **IP protection category:** IP 67
- **Package contains:** battery, instruction manual, case

| Order no. | Type | Measuring range | Measuring range | Resolution | Error limit | Standard | Depth Rod |
|-----------|------------|-----------------|-----------------|---------------|-------------|------------------|-------------|
| | | mm | inch | mm/inch | mm | | |
| 4103384 | 16 EWri-BA | 10 – 210 | 0.4 – 8.3" | 0.01 / .0005" | 0.04 | Factory standard | rectangular |
| 4103084 | 16 EWR-BA | 10 – 210 | 0.4 – 8.3" | 0.01 / .0005" | 0.04 | Factory standard | rectangular |

| Order no. | d | e |
|-----------|-----|----|
| | mm | mm |
| 4103384 | 278 | 16 |
| 4103084 | 278 | 16 |

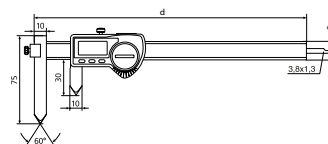

FEATURES 16 EWR-BA:

- **Digital height:** 8.5 mm
- **Data interface:** USB, Opto RS-232C, Digimatic
- **Energy supply:** Battery life approx. 3 years

ACCESSORIES

| Order no. | For measuring instrument | Description | Type |
|-----------|--------------------------|---|---------|
| 4102220 | 16 EWri-BA | Receiver for instruments with Integrated Wireless | i-Stick |
| 4102357 | 16 EWR-BA | 16 EXu data connection cable USB (2 m) | 16 EXu |
| 4102410 | 16 EWR-BA | Data connection cable RS232C (2 m) | 16 EXr |
| 4102915 | 16 EWR-BA | Interface adapter with data cable Digimatic (2 m) | 16 EWd |



i-Stick

MarCal 16 EWri-SA / 16 EWR-SA

Digital special calipers

FUNCTIONS

16 EWri-SA:

- ON/OFF
- AUTO-ON / OFF
- mm/inch
- LOCK function (key lock)
- RESET (set display to zero)
- PRESET (for entering a numerical value)
- DATA (data transmission)
- HOLD (storage of measured values)



16 EWri-SA

16 EWR-SA:

- ON/OFF
- AUTO-ON / OFF
- mm/inch
- LOCK function (key lock)
- RESET (set display to zero)
- DATA (data transmission via connection cable)
- High contrast digital display
- Locking screw above
- Lapped guideway
- Slide and beam made of hardened stainless steel
- Immediate measurements due to the Reference System
- Raised guideway for the protection of the scale
- Excellent resistance against dust, coolants and lubricants
- Dirt wipers are integrated in the slide



16 EWR-SA

Application:

- Inward-angled measuring tips for measuring wall thicknesses and recesses on shafts

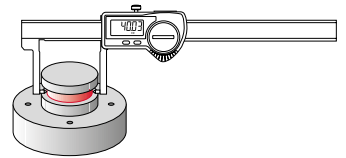

FEATURES 16 EWri-SA:

- **Software:** MarCom Professional free download: www.mahr.com/marcom (only for Mahr data cables and wireless systems with USB and RS-232 interface)
- **Digital height:** 11 mm
- **Data interface:** Integrated Wireless
- **Energy supply:** Battery life approx. 3 years (approx. 0.5 in wireless mode)
- **Battery type:** CR 2032 (3V Lithium)
- **IP protection category:** IP 67
- **Package contains:** battery, instruction manual, case

TECHNICAL DATA

| Order no. | Type | Measuring range | Measuring range | Resolution | Error limit | Standard | Depth rod |
|-----------|------------|-----------------|-----------------|---------------|-------------|------------------|-----------|
| | | mm | inch | mm/inch | mm | | |
| 4103377 | 16 EWri-SA | 0 – 140 | 0 – 6" | 0.01 / .0005" | 0.03 | Factory standard | none |
| 4103077 | 16 EWR-SA | 0 – 140 | 0 – 6" | 0.01 / .0005" | 0.03 | Factory standard | none |

| Order no. | b | d | e |
|-----------|----|-----|----|
| | mm | mm | mm |
| 4103377 | 40 | 235 | 16 |
| 4103077 | 40 | 235 | 16 |

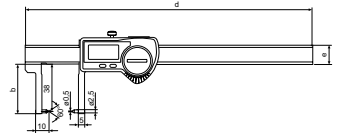

FEATURES 16 EWR-SA:

- **Digital height:** 8.5 mm
- **Data interface:** USB, Opto RS-232C, Digimatic
- **Energy supply:** Battery life approx. 3 years

ACCESSORIES

| Order no. | For measuring instrument | Description | Type |
|-----------|--------------------------|---|---------|
| 4102220 | 16 EWri-SA | Receiver for instruments with Integrated Wireless | i-Stick |
| 4102357 | 16 EWR-SA | 16 EXu data connection cable USB (2 m) | 16 EXu |
| 4102410 | 16 EWR-SA | Data connection cable RS232C (2 m) | 16 EXr |
| 4102915 | 16 EWR-SA | Interface adapter with data cable Digimatic (2 m) | 16 EWd |



i-Stick

MarCal 16 EWri-AA / 16 EWR-AA

Digital special calipers

FUNCTIONS

16 EWri-AA:

- ON/OFF
- AUTO-ON / OFF
- mm/inch
- LOCK function (key lock)
- RESET (set display to zero)
- PRESET (for entering a numerical value)
- DATA (data transmission)
- HOLD (storage of measured values)



16 EWri-AA



16 EWR-AA:

- ON/OFF
- AUTO-ON / OFF
- mm/inch
- LOCK function (key lock)
- RESET (set display to zero)
- DATA (data transmission via connection cable)
- High contrast digital display
- Locking screw above
- Lapped guideway
- Slide and beam made of hardened stainless steel
- Immediate measurements due to the Reference System
- Raised guideway for the protection of the scale
- Excellent resistance against dust, coolants and lubricants
- Dirt wipers are integrated in the slide



16 EWR-AA



Application:

- Inward-angled measuring surfaces for measuring wall thicknesses and recesses on shafts

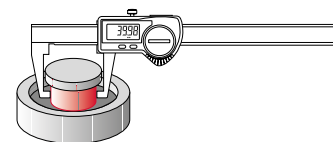

FEATURES 16 EWri-AA:

- **Software:** MarCom Professional free download: www.mahr.com/marcom (only for Mahr data cables and wireless systems with USB and RS-232 interface)
- **Digital height:** 11 mm
- **Data interface:** Integrated Wireless
- **Energy supply:** Battery life approx. 3 years (approx. 0.5 in wireless mode)
- **Battery type:** CR 2032 (3V Lithium)
- **IP protection category:** IP 67
- **Package contains:** battery, instruction manual, case

TECHNICAL DATA

| Order no. | Type | Measuring range | Measuring range | Resolution | Error limit | Standard | Depth Rod |
|-----------|------------|-----------------|-----------------|---------------|-------------|------------------|-----------|
| | | mm | inch | mm/inch | mm | | |
| 4103379 | 16 EWri-AA | 0 – 150 | 0 – 6" | 0.01 / .0005" | 0.03 | Factory standard | none |
| 4103079 | 16 EWR-AA | 0 – 150 | 0 – 6" | 0.01 / .0005" | 0.03 | Factory standard | none |

| Order no. | b | d | e |
|-----------|----|-----|----|
| | mm | mm | mm |
| 4103379 | 40 | 235 | 16 |
| 4103079 | 40 | 235 | 16 |

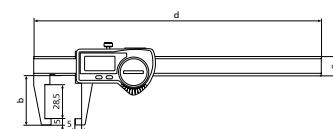

FEATURES 16 EWR-AA:

- **Digital height:** 8.5 mm
- **Data interface:** USB, Opto RS-232C, Digimatic
- **Energy supply:** Battery life approx. 3 years

ACCESSORIES

| Order no. | For measuring instrument | Description | Type |
|-----------|--------------------------|---|---------|
| 4102220 | 16 EWri-AA | Receiver for instruments with Integrated Wireless | i-Stick |
| 4102357 | 16 EWR-AA | 16 EXu data connection cable USB (2 m) | 16 EXu |
| 4102410 | 16 EWR-AA | Data connection cable RS232C (2 m) | 16 EXr |
| 4102915 | 16 EWR-AA | Interface adapter with data cable Digimatic (2 m) | 16 EWd |



i-Stick

MarCal 16 EWri-SI / 16 EWR-SI

Digital special calipers

FUNCTIONS

16 EWri-SI:

- ON/OFF
- AUTO-ON / OFF
- mm/inch
- LOCK function (key lock)
- RESET (set display to zero)
- PRESET (for entering a numerical value)
- DATA (data transmission)
- HOLD (storage of measured values)

16 EWR-SI:

- ON/OFF
- AUTO-ON / OFF
- mm/inch
- LOCK function (key lock)
- RESET (set display to zero)
- PRESET (for entering a numerical value)
- DATA (data transmission via connection cable)
- High contrast digital display
- Locking screw above
- Lapped guideway
- Slide and beam made of hardened stainless steel
- Immediate measurements due to the Reference System
- Raised guideway for the protection of the scale
- Excellent resistance against dust, coolants and lubricants
- Dirt wipers are integrated in the slide



16 EWri-SI



16 EWR-SI

Application:

- Outward-angled measuring tips for measuring recesses in bores

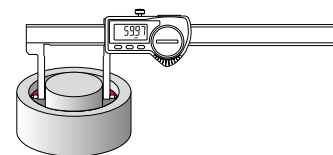

TECHNICAL DATA

| Order no. | Type | Measuring range | Measuring range | Resolution | Error limit | Standard | Depth Rod |
|-----------|------------|-----------------|-----------------|---------------|-------------|------------------|-----------|
| | | mm | inch | mm/inch | mm | | |
| 4103378 | 16 EWri-SI | 20 – 170 | 0.8 – 6.7" | 0.01 / .0005" | 0.03 | Factory standard | none |
| 4103078 | 16 EWR-SI | 20 – 170 | 0.8 – 6.7" | 0.01 / .0005" | 0.03 | Factory standard | none |

| Order no. | b | d | e |
|-----------|----|-----|----|
| | mm | mm | mm |
| 4103378 | 28 | 235 | 16 |
| 4103078 | 28 | 235 | 16 |

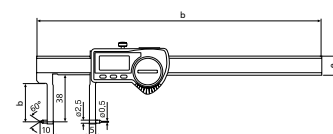

FEATURES 16 EWri-SI:

- **Software:** MarCom Professional free download: www.mahr.com/marcom (only for Mahr data cables and wireless systems with USB and RS-232 interface)
- **Digital height:** 11 mm
- **Data interface:** Integrated Wireless
- **Energy supply:** Battery life approx. 3 years (approx. 0.5 in wireless mode)
- **Battery type:** CR 2032 (3V Lithium)
- **IP protection category:** IP 67
- **Package contains:** battery, instruction manual, case

FEATURES 16 EWR-SI:

- **Digital height:** 8.5 mm
- **Data interface:** USB, Opto RS-232C, Digimatic
- **Energy supply:** Battery life approx. 3 years

ACCESSORIES

| Order no. | For measuring instrument | Description | Type |
|-----------|--------------------------|---|---------|
| 4102220 | 16 EWri-SI | Receiver for instruments with Integrated Wireless | i-Stick |
| 4102357 | 16 EWR-SI | 16 EXu data connection cable USB (2 m) | 16 EXu |
| 4102410 | 16 EWR-SI | Data connection cable RS232C (2 m) | 16 EXr |
| 4102915 | 16 EWR-SI | Interface adapter with data cable Digimatic (2 m) | 16 EWd |



i-Stick

MarCal 16 EWri-AI / 16 EWR-AI

Digital special calipers

FUNCTIONS

16 EWri-AI:

- ON/OFF
- AUTO-ON / OFF
- mm/inch
- LOCK function (key lock)
- RESET (set display to zero)
- PRESET (for entering a numerical value)
- DATA (data transmission)
- HOLD (storage of measured values)



16 EWR-AI:

- ON/OFF
- AUTO-ON / OFF
- mm/inch
- LOCK function (key lock)
- RESET (set display to zero)
- PRESET (for entering a numerical value)
- DATA (data transmission via connection cable)
- High contrast digital display
- Locking screw above
- Lapped guideway
- Slide and beam made of hardened stainless steel
- Immediate measurements due to the Reference System
- Raised guideway for the protection of the scale
- Excellent resistance against dust, coolants and lubricants
- Dirt wipers are integrated in the slide

16 EWri-AI



16 EWR-AI

Application:

- Outward-angled measuring surfaces for measuring recesses in bores

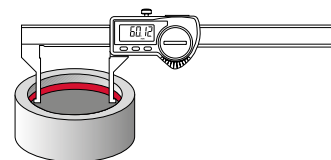

FEATURES 16 EWri-AI:

- **Software:** MarCom Professional free download: www.mahr.com/marcom (only for Mahr data cables and wireless systems with USB and RS-232 interface)
- **Digital height:** 11 mm
- **Data interface:** Integrated Wireless
- **Energy supply:** Battery life approx. 3 years (approx. 0.5 in wireless mode)
- **Battery type:** CR 2032 (3V Lithium)
- **IP protection category:** IP 67
- **Package contains:** battery, instruction manual, case

TECHNICAL DATA

| Order no. | Type | Measuring range | Measuring range | Resolution | Error limit | Standard | Depth rod |
|-----------|------------|-----------------|-----------------|---------------|-------------|------------------|-----------|
| | | mm | inch | mm/inch | mm | | |
| 4103380 | 16 EWri-AI | 10 – 160 | 0.4 – 6.3" | 0.01 / .0005" | 0.03 | Factory standard | none |
| 4103080 | 16 EWR-AI | 10 – 160 | 0.4 – 6.3" | 0.01 / .0005" | 0.03 | Factory standard | none |

| Order no. | b | d | e |
|-----------|----|-----|----|
| | mm | mm | mm |
| 4103380 | 40 | 235 | 16 |
| 4103080 | 40 | 235 | 16 |

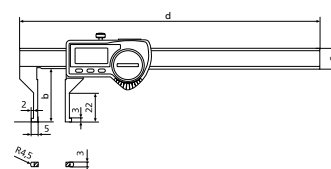

FEATURES 16 EWR-AI:

- **Digital height:** 8.5 mm
- **Data interface:** USB, Opto RS-232C, Digimatic
- **Energy supply:** Battery life approx. 3 years

ACCESSORIES

| Order no. | For measuring instrument | Description | Type |
|-----------|--------------------------|---|---------|
| 4102220 | 16 EWri-AI | Receiver for instruments with Integrated Wireless | i-Stick |
| 4102357 | 16 EWR-AI | 16 EXu data connection cable USB (2 m) | 16 EXu |
| 4102410 | 16 EWR-AI | Data connection cable RS232C (2 m) | 16 EXr |
| 4102915 | 16 EWR-AI | Interface adapter with data cable Digimatic (2 m) | 16 EWd |



i-Stick

MarCal 16 EWRI-RW / 16 EWR-RW

Digital special calipers

FUNCTIONS

16 EWRI-RW:

- ON/OFF
- AUTO-ON / OFF
- mm/inch
- LOCK function (key lock)
- RESET (set display to zero)
- PRESET (for entering a numerical value)
- DATA (data transmission)
- HOLD (storage of measured values)



16 EWRI-RW

16 EWR-RW:

- ON/OFF
- AUTO-ON / OFF
- mm/inch
- LOCK function (key lock)
- RESET (set display to zero)
- DATA (data transmission via connection cable)
- High contrast digital display
- Locking screw above
- Lapped guideway
- Slide and beam made of hardened stainless steel
- Immediate measurements due to the Reference System
- Raised guideway for the protection of the scale
- Excellent resistance against dust, coolants and lubricants
- Dirt wipers are integrated in the slide



16 EWR-RW

Application:

- Measurement of wall thicknesses

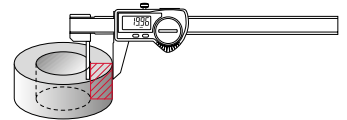

FEATURES 16 EWRI-RW:

- **Software:** MarCom Professional free download: www.mahr.com/marcom (only for Mahr data cables and wireless systems with USB and RS-232 interface)
- **Digital height:** 11 mm
- **Data interface:** Integrated Wireless
- **Energy supply:** Battery life approx. 3 years (approx. 0.5 in wireless mode)
- **Battery type:** CR 2032 (3V Lithium)
- **IP protection category:** IP 67
- **Package contains:** battery, instruction manual, case

FEATURES 16 EWR-RW:

- **Digital height:** 8.5 mm
- **Data interface:** USB, Opto RS-232C, Digimatic
- **Energy supply:** Battery life approx. 3 years

TECHNICAL DATA

| Order no. | Type | Measuring range | Measuring range | Resolution | Error limit | Standard | Depth rod |
|-----------|------------|-----------------|-----------------|---------------|-------------|------------------|-----------|
| | | mm | inch | mm/inch | mm | | |
| 4103381 | 16 EWRI-RW | 0 – 150 | 0 – 6" | 0.01 / .0005" | 0.05 | Factory standard | none |
| 4103081 | 16 EWR-RW | 0 – 150 | 0 – 6" | 0.01 / .0005" | 0.05 | Factory standard | none |

| Order no. | b | d | e |
|-----------|----|-----|----|
| | mm | mm | mm |
| 4103381 | 40 | 235 | 16 |
| 4103081 | 40 | 235 | 16 |

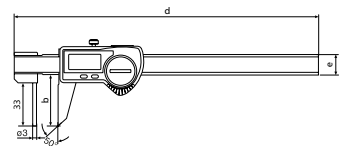

ACCESSORIES

| Order no. | For measuring instrument | Description | Type |
|-----------|--------------------------|---|---------|
| 4102220 | 16 EWRI-RW | Receiver for instruments with Integrated Wireless | i-Stick |
| 4102357 | 16 EWR-RW | 16 EXu data connection cable USB (2 m) | 16 EXu |
| 4102410 | 16 EWR-RW | Data connection cable RS232C (2 m) | 16 EXr |
| 4102915 | 16 EWR-RW | Interface adapter with data cable Digimatic (2 m) | 16 EWd |



i-Stick

MarCal 16 EWri-LI / 16 EWR-LI

Digital special calipers

FUNCTIONS



16 EWri-LI:

- ON/OFF
- AUTO-ON / OFF
- mm/inch
- LOCK function (key lock)
- RESET (set display to zero)
- PRESET (for entering a numerical value)
- DATA (data transmission)
- HOLD (storage of measured values)



16 EWri-LI

16 EWR-LI:

- ON/OFF
- AUTO-ON / OFF
- mm/inch
- LOCK function (key lock)
- RESET (set display to zero)
- PRESET (for entering a numerical value)
- DATA (data transmission via connection cable)
- High contrast digital display
- Locking screw above
- Lapped guideway
- Measuring blade for inside measurements
- Slide and beam made of hardened stainless steel
- Immediate measurements due to the Reference System
- Raised guideway for the protection of the scale
- Excellent resistance against dust, coolants and lubricants
- Dirt wipers are integrated in the slide



16 EWR-LI

Application:

- With long internal cutting edges

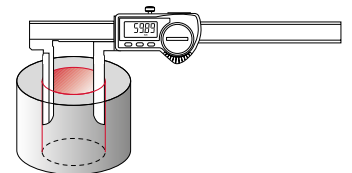

TECHNICAL DATA

| Order no. | Type | Measuring range | Measuring range | Resolution | Error limit | Standard | Depth rod |
|-----------|------------|-----------------|-----------------|---------------|-------------|------------------|-----------|
| | | mm | inch | mm/inch | mm | | |
| 4103385 | 16 EWri-LI | 10 – 200 | 0.4 – 8" | 0.01 / .0005" | 0.05 | Factory standard | none |
| 4103085 | 16 EWR-LI | 10 – 200 | 0.4 – 8" | 0.01 / .0005" | 0.05 | Factory standard | none |

| Order no. | b | d | e |
|-----------|----|-----|----|
| | mm | mm | mm |
| 4103385 | 60 | 285 | 16 |
| 4103085 | 60 | 285 | 16 |

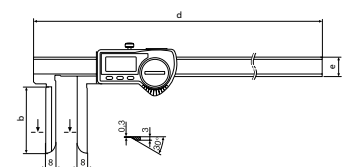

FEATURES 16 EWri-LI:

- **Software:** MarCom Professional free download: www.mahr.com/marcom (only for Mahr data cables and wireless systems with USB and RS-232 interface)
- **Digital height:** 11 mm
- **Data interface:** Integrated Wireless
- **Energy supply:** Battery life approx. 3 years (approx. 0.5 in wireless mode)
- **Battery type:** CR 2032 (3V Lithium)
- **IP protection category:** IP 67
- **Package contains:** battery, instruction manual, case

FEATURES 16 EWR-LI:

- **Digital height:** 8.5 mm
- **Data interface:** USB, Opto RS-232C, Digimatic
- **Energy supply:** Battery life approx. 3 years

ACCESSORIES

| Order no. | For measuring instrument | Description | Type |
|-----------|--------------------------|---|---------|
| 4102220 | 16 EWri-LI | Receiver for instruments with Integrated Wireless | i-Stick |
| 4102357 | 16 EWR-LI | 16 EXu data connection cable USB (2 m) | 16 EXu |
| 4102410 | 16 EWR-LI | Data connection cable RS232C (2 m) | 16 EXr |
| 4102915 | 16 EWR-LI | Interface adapter with data cable Digimatic (2 m) | 16 EWd |



i-Stick

MarCal 30 EWRI / 30 EWR

Digital depth gage

FUNCTIONS

30 EWRI:

- ON/OFF
- AUTO-ON / OFF
- RESET (set display to zero)
- mm/inch
- PRESET (for entering a numerical value)
- LOCK function (key lock)
- HOLD (storage of measured values)
- Reversal of counting direction
- DATA (data transmission)

30 EWR:

- AUTO-ON / OFF
- DATA (data transmission via connection cable)
- ON/OFF
- PRESET (for entering a numerical value)
- RESET (set display to zero)
- mm/inch
- LOCK function (key lock)
- High contrast digital display
- Locking screw above
- Lapped guideway
- Measuring surfaces made of steel
- Slide and beam made of hardened stainless steel
- Immediate measurements due to the Reference System
- Raised guideway for the protection of the scale
- Excellent resistance against dust, coolants and lubricants
- Dirt wipers are integrated in the slide

FEATURES 30 EWRI:

- **Digital height:** 11 mm
- **Data interface:** Integrated Wireless
- **Energy supply:** Battery life approx. 3 years (approx. 0.5 in wireless mode)
- **Battery type:** CR 2032 (3V Lithium)
- **IP protection category:** IP 67
- **Package contains:** battery, instruction manual, case

FEATURES 30 EWR:

- **Digital height:** 8.5 mm
- **Data interface:** USB, Opto RS-232C, Digimatic
- **Energy supply:** Battery life approx. 3 years
- **Battery type:** CR 2032 (3V Lithium)
- **IP protection category:** IP 67
- **Package contains:** battery, instruction manual, case

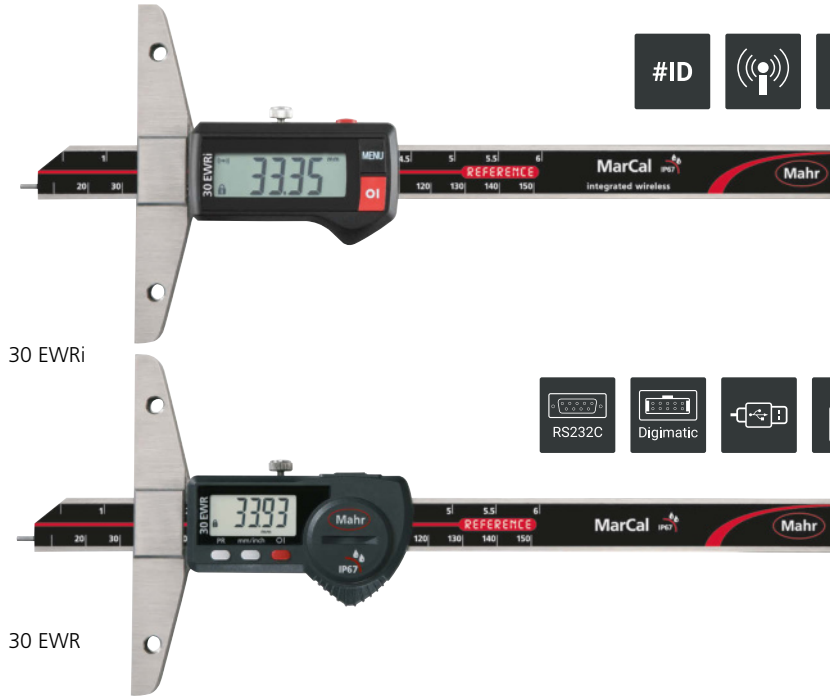

TECHNICAL DATA

| Order no. | Type | Measuring range | | Resolution | Error limit | Standard |
|-----------|---------|-----------------|-------|---------------|-------------|------------------|
| | | mm | inch | | | |
| 4126755 | 30 EWRI | 0–150 | 0–6" | 0.01 / .0005" | 0.03 | Factory standard |
| 4126754 | 30 EWRI | 0–200 | 0–8" | 0.01 / .0005" | 0.03 | Factory standard |
| 4126756 | 30 EWRI | 0–300 | 0–12" | 0.01 / .0005" | 0.04 | Factory standard |
| 4126757 | 30 EWRI | 0–500 | 0–20" | 0.01 / .0005" | 0.05 | Factory standard |
| 4126700 | 30 EWR | 0–150 | 0–6" | 0.01 / .0005" | 0.03 | Factory standard |
| 4126699 | 30 EWR | 0–200 | 0–8" | 0.01 / .0005" | 0.03 | Factory standard |
| 4126701 | 30 EWR | 0–300 | 0–12" | 0.01 / .0005" | 0.04 | Factory standard |
| 4126702 | 30 EWR | 0–500 | 0–20" | 0.01 / .0005" | 0.05 | Factory standard |

| Order no. | a | b |
|-----------|-----|-----|
| | mm | mm |
| 4126755 | 234 | 100 |
| 4126754 | 284 | 100 |
| 4126756 | 384 | 150 |
| 4126757 | 584 | 150 |
| 4126700 | 234 | 100 |
| 4126699 | 284 | 100 |
| 4126701 | 384 | 150 |
| 4126702 | 584 | 150 |

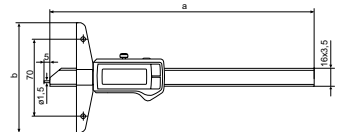

ACCESSORIES

| Order no. | For measuring instrument | Description | Quantity | unit | Type |
|-----------|--------------------------|---|----------|-------|---------|
| 4102220 | 30 EWRI | Receiver for instruments with Integrated Wireless | | | i-Stick |
| 4102357 | 30 EWR | 16 EXu data connection cable USB (2 m) | | | 16 EXu |
| 4102410 | 30 EWR | Data connection cable RS232C (2 m) | | | 16 EXr |
| 4102915 | 30 EWR | Interface adapter with data cable Digimatic (2 m) | | | 16 EWd |
| 4125611 | 30 EWRI, 30 EWR | Anvil (4 mm) | | Piece | 30 ESa |
| 4126510 | 30 EWRI, 30 EWR | Cross beam extension (300 mm) | | | 30 EXm |
| 4126511 | 30 EWRI, 30 EWR | Cross beam extension (200 mm) | | | 30 EXm |

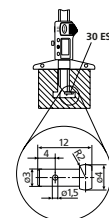
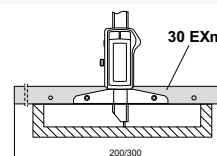

MarCal 30 EWri

Digital depth gage



FUNCTIONS

- ON/OFF
- AUTO-ON / OFF
- RESET (set display to zero)
- mm/inch
- PRESET (for entering a numerical value)
- LOCK function (key lock)
- HOLD (storage of measured values)
- Reversal of counting direction
- DATA (data transmission)



FEATURES

- High contrast digital display
- Locking screw above
- Lapped guideway
- Measuring surfaces made of steel
- Slide and beam made of hardened stainless steel
- Immediate measurements due to the Reference System
- Raised guideway for the protection of the scale
- Excellent resistance against dust, coolants and lubricants
- Dirt wipers are integrated in the slide
- **Software:** MarCom Professional free download: www.mahr.com/marcom (only for Mahr data cables and wireless systems with USB and RS-232 interface)
- **Data interface:** Integrated Wireless
- **Energy supply:** Battery life approx. 3 years (approx. 0.5 in wireless mode)
- **Battery type:** CR 2032 (3V Lithium)
- **IP protection category:** IP 67
- **Package contains:** battery, instruction manual, case

Applications:

- Small, handy, practical
- Ideal for mobile use in manufacturing and inspection as well as assembly
- For small measuring depths in holes, grooves, etc.

TECHNICAL DATA

| Order no. | Type | Measuring range | Measuring range | Resolution | Error limit | Standard | Depth rod |
|-----------|---------|-----------------|-----------------|---------------|-------------|------------------|-----------|
| | | mm | inch | mm/inch | mm | | |
| 4126751 | 30 EWri | 0–25 | 0–1" | 0.01 / .0005" | 0.02 | Factory standard | round |

| Order no. | a | b |
|-----------|-----|----|
| | mm | mm |
| 4126751 | 129 | 48 |

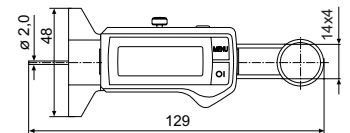

ACCESSORIES

| Order no. | Description | Type |
|-----------|---|---------|
| 4102220 | Receiver for instruments with Integrated Wireless | i-Stick |



i-Stick

MarCal 30 EWri-D / 30 EWR-D

Digital depth gage

FUNCTIONS

30 EWri-D:

- ON/OFF
- AUTO-ON / OFF
- mm/inch
- LOCK function (key lock)
- RESET (set display to zero)
- PRESET (for entering a numerical value)
- DATA (data transmission)
- HOLD (storage of measured values)

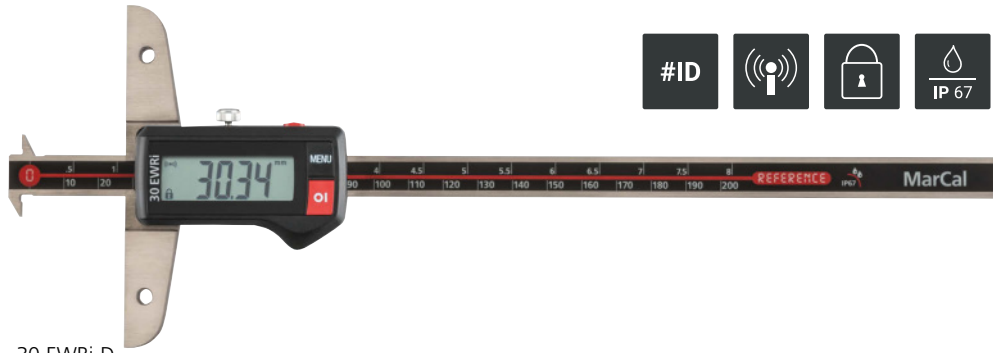

30 EWri-D



30 EWR-D:

- ON/OFF
- AUTO-ON / OFF
- mm/inch
- LOCK function (key lock)
- RESET (set display to zero)
- PRESET (for entering a numerical value)
- DATA (data transmission via connection cable)
- High contrast digital display
- Locking screw above
- Lapped guideway
- Measuring surfaces made of steel
- Slide and beam made of hardened stainless steel
- Immediate measurements due to the Reference System
- Raised guideway for the protection of the scale
- Excellent resistance against dust, coolants and lubricants
- Dirt wipers are integrated in the slide



30 EWR-D



Application:

- Measuring groove widths and distances between grooves

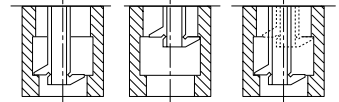

TECHNICAL DATA

| Order no. | Type | Measuring range | | Resolution | Error limit | Standard |
|-----------|-----------|-----------------|---------|---------------|-------------|------------------|
| | | mm | inch | | | |
| 4126533 | 30 EWri-D | 0 – 200 | 0 – 8" | 0.01 / .0005" | 0.03 | Factory standard |
| 4126534 | 30 EWri-D | 0 – 300 | 0 – 12" | 0.01 / .0005" | 0.04 | Factory standard |
| 4126523 | 30 EWR-D | 0 – 200 | 0 – 8" | 0.01 / .0005" | 0.03 | Factory standard |
| 4126524 | 30 EWR-D | 0 – 300 | 0 – 12" | 0.01 / .0005" | 0.04 | Factory standard |

| Order no. | a | b | c |
|-----------|-----|-----|----|
| | mm | mm | mm |
| 4126533 | 281 | 100 | 12 |
| 4126534 | 381 | 150 | 12 |
| 4126523 | 281 | 100 | 12 |
| 4126524 | 381 | 150 | 12 |

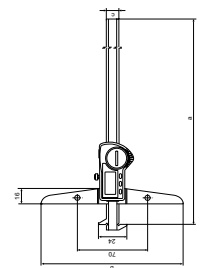

FEATURES 30 EWri-D:

- **Digital height:** 11 mm
- **Data interface:** Integrated Wireless
- **Energy supply:** Battery life approx. 3 years (approx. 0.5 in wireless mode)
- **Battery type:** CR 2032 (3V Lithium)
- **IP protection category:** IP 67
- **Package contains:** battery, instruction manual, case

FEATURES 30 EWR-D:

- **Digital height:** 8.5 mm
- **Data interface:** USB, Opto RS-232C, Digimatic
- **Energy supply:** Battery life approx. 3 years
- **Battery type:** CR 2032 (3V Lithium)
- **IP protection category:** IP 67
- **Package contains:** battery, instruction manual, case

ACCESSORIES

| Order no. | For measuring instrument | Description | Type |
|-----------|--------------------------|---|---------|
| 4102220 | 30 EWri-D | Receiver for instruments with Integrated Wireless | i-Stick |
| 4102357 | 30 EWR-D | 16 EXu data connection cable USB (2 m) | 16 EXu |
| 4102410 | 30 EWR-D | Data connection cable RS232C (2 m) | 16 EXr |
| 4102915 | 30 EWR-D | Interface adapter with data cable Digimatic (2 m) | 16 EWd |
| 4126510 | 30 EWri-D, 30 EWR-D | Cross beam extension (300 mm) | 30 EXm |
| 4126511 | 30 EWri-D, 30 EWR-D | Cross beam extension (200 mm) | 30 EXm |

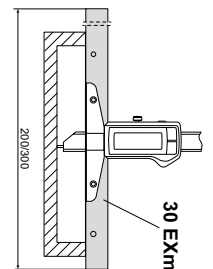

i-Stick

MarCal 30 EWri-N / 30 EWR-N

Digital depth gage

FUNCTIONS

30 EWri-N:

- ON/OFF
- AUTO-ON / OFF
- mm/inch
- LOCK function (key lock)
- RESET (set display to zero)
- PRESET (for entering a numerical value)
- DATA (data transmission)
- HOLD (storage of measured values)



30 EWR-N:

- ON/OFF
- AUTO-ON / OFF
- mm/inch
- LOCK function (key lock)
- RESET (set display to zero)
- PRESET (for entering a numerical value)
- DATA (data transmission via connection cable)
- High contrast digital display
- Locking screw above
- Lapped guideway
- Measuring surfaces made of steel
- Slide and beam made of hardened stainless steel
- Immediate measurements due to the Reference System
- Raised guideway for the protection of the scale
- Excellent resistance against dust, coolants and lubricants
- Dirt wipers are integrated in the slide



Application:

- Measuring groove widths and distances between grooves

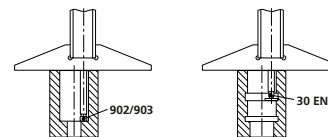

TECHNICAL DATA

| Order no. | Type | Measuring range | | Resolution | Error limit | Standard |
|-----------|-----------|-----------------|--------|---------------|-------------|------------------|
| | | mm | inch | | | |
| 4126532 | 30 EWri-N | 0 – 100 | 0 – 4" | 0.01 / .0005" | 0.03 | Factory standard |
| 4126513 | 30 EWR-N | 0 – 100 | 0 – 4" | 0.01 / .0005" | 0.03 | Factory standard |

FEATURES 30 EWri-N:

- **Digital height:** 11 mm
- **Data interface:** Integrated Wireless
- **Energy supply:** Battery life approx. 3 years (approx. 0.5 in wireless mode)
- **Battery type:** CR 2032 (3V Lithium)
- **IP protection category:** IP 67
- **Package contains:** battery, instruction manual, anvils 30 Ent (1mm), 902 (4mm) and 903 (4mm), case

| Order no. | a | b | c |
|-----------|-----|----|----|
| | mm | mm | mm |
| 4126532 | 268 | 85 | 16 |
| 4126513 | 268 | 85 | 16 |

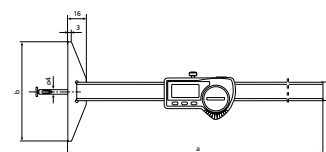

FEATURES 30 EWR-N:

- **Digital height:** 8.5 mm
- **Data interface:** USB, Opto RS-232C, Digimatic
- **Energy supply:** Battery life approx. 3 years

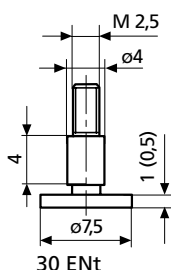

ACCESSORIES

| Order no. | For measuring instrument | Description | Quantity | unit | Type |
|-----------|--------------------------|---|----------|------|---------|
| 4102220 | 30 EWri-N | Receiver for instruments with Integrated Wireless | | | i-Stick |
| 4102357 | 30 EWR-N | 16 EXu data connection cable USB (2 m) | 16 | EXu | |
| 4102410 | 30 EWR-N | Data connection cable RS232C (2 m) | 16 | EXr | |
| 4102915 | 30 EWR-N | Interface adapter with data cable Digimatic (2 m) | 16 | EWd | |
| 4126310 | 30 EWR-N, 30 EWri-N | Disc type anvil (7.5 x 0.5 mm) | Piece | | 30 ENT |
| 4882022 | 30 EWR-N, 30 EWri-N | Disc type anvil (7.5 x 1 mm) | Piece | | 30 ENT |



Micromar | Micrometers

Micrometers are among the most frequently used handheld measuring instruments. Products in the Micromar series boast superior precision and impressive reliability. The latest generation of waterproof digital micrometers can be used in even the toughest workshop conditions.



| | |
|---|-----------|
| Overview Micromar micrometers | 62 |
| Outside micrometers | |
| Micromar 40 EWRI / 40 EWR / 40 ER With digital display | 64 |
| Micromar 40 EWRI-L / 40 EWR-L With digital display | 68 |
| Micromar 40 A / 40 SA With scale display | 70 |
| Micromar 40 F / 40 FC / 40 T / 40 TS Dial comparators | 71 |
| Micromar 40 EWRI-V / 40 EWR-V Digital outside micrometers | 74 |
| Micromar 40 EWRI-S / 40 EWR-S Digital outside micrometers | 80 |
| Micromar 40 EWRI-B / 40 EWR-B Digital outside micrometers | 82 |
| Micromar 40 EWRI-R / 40 EWR-R Digital outside micrometers | 84 |
| Micromar 40 EWRI-K / 40 EWR-K Digital outside micrometers | 86 |
| Micromar 44 F / 44 Cm / 44 Cms Inside micrometers | 88 |
| Micromar 44 A / 44 AS / 44 EWR / 844 A / 844 AS Self-centering inside micrometers | 90 |
| Micromar individual sub-elements 44 EWg / 844 Ag / 44 Ak / 45 T | 98 |

Micromar | Digital micrometer Micromar 40 EWRi micrometers with Integrated Wireless

With the Micromar 40 EWRi digital waterproof micrometer,, precise and reliable results are obtained even in the most difficult conditions.



Integrated Wireless

offers you much more freedom. Whether at the measuring workspace, for inspections inside or on the machine, in the case of large workpieces, you get fully autonomous measuring without limits by a cable.

High-contrast display

with 10 mm high digits enables accurate, fatigue-free reading of the measurement results.



Reference Lock

function prevents operating error caused by accidental usage of the operating buttons.

Stainless steel, hardened spindle



Tolerance function with warning limits:

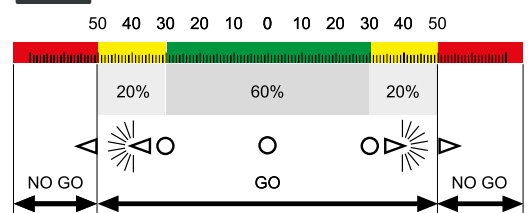

Hold

Freezes the measured value after the measurement. Practical function for measuring tasks, where the display is not visible, i.e. measurements in the machine.

Steel frame

Sturdy hard lacquered

ABS

Absolute function

Micrometer can be set in any position to 0.000 mm / .0000" without the reference to the preset value being lost

The ergonomically formed and thermally insulated handle as well as the integrated ratchet in the thimble ensures both trouble free handling and accurate measurement results.



Protection class IP65 in accordance to IEC 60529, the waterproof measuring system FPS (Fluid Protected measuring System) with a sealed housing.



Micromar | Design features

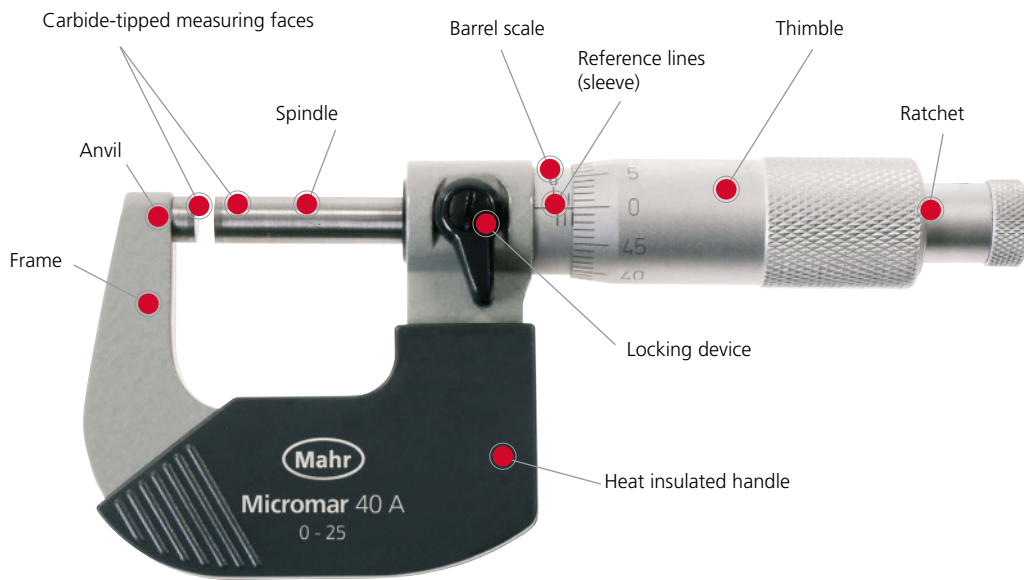

Reading example:

Micrometer with 0.01 mm divisions

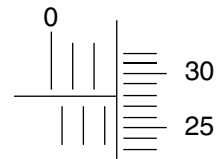

| | |
|------------------|---------|
| Sleeve | 2.5 |
| Thimble | 0.28 |
| Measuring result | 2.78 mm |

Micromar | Types of micrometers

Mahr micrometers are available in the following display variants:

a) Digital micrometer with digital display



b) Mechanical micrometer with scale and dial



c) Mechanical micrometer with scale



Error limits G according to DIN 863-1

| Measuring range | Error limit | | Measuring force |
|-----------------|---------------|--------|-----------------|
| | G | | |
| mm | μm | N | |
| 0 – 25 | 4 | 5 – 10 | |
| 25 – 50 | 4 | 5 – 10 | |
| 50 – 75 | 5 | 5 – 10 | |
| 75 – 100 | 5 | 5 – 10 | |
| 100 – 125 | 6 | 5 – 10 | |
| 125 – 150 | 6 | 5 – 10 | |
| 150 – 175 | 7 | 5 – 10 | |
| 175 – 200 | 7 | 5 – 10 | |
| 200 – 225 | 8 | 5 – 10 | |
| 225 – 250 | 8 | 5 – 10 | |
| 250 – 275 | 9 | 5 – 10 | |
| 275 – 300 | 9 | 5 – 10 | |
| 300 – 325 | 10 | 5 – 10 | |
| 325 – 350 | 10 | 5 – 10 | |
| 350 – 375 | 11 | 5 – 10 | |
| 375 – 400 | 11 | 5 – 10 | |
| 400 – 425 | 12 | 5 – 10 | |
| 425 – 450 | 12 | 5 – 10 | |
| 450 – 475 | 13 | 5 – 10 | |
| 475 – 500 | 13 | 5 – 10 | |

Micromar 40 EWRI

Digital outside micrometers



FUNCTIONS

- RESET (set display to zero)
- ABS (display can be set to zero without losing reference to ORIGIN)
- mm/inch
- ORIGIN (for entering a numerical value)
- LOCK function (key lock)
- TOL (Tolerance and Warning Limits Input)
- HOLD (storage of measured values)
- DATA (data transmission)
- Bidirectional data interface (external output and input option of characteristic values as well as setting of individual lock functions by MarCom Software)

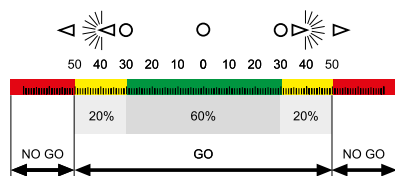

FEATURES

- High contrast digital display
- Stainless spindle is hardened throughout and ground
- Spindle and anvil are carbide-tipped
- Rapid drive
- Ratchet is integrated in the thimble
- Lacquered steel frame, heat insulated
- **Software:** MarCom Professional free download: www.mahr.com/marcom (only for Mahr data cables and wireless systems with USB and RS-232 interface)
- **Digit height:** 10 mm
- **Data interface:** Integrated Wireless
- **Energy supply:** Battery life approx. 3 years (approx. 0.5 in wireless mode)
- **Battery type:** CR 2032 (3V Lithium)
- **IP protection category:** IP 65
- **Package contains:** instruction manual, battery, setting values, case

TECHNICAL DATA

| Order no. | Type | Measuring range | | Measuring surface | Resolution | Error limit | Parallelism deviation | Flatness deviation |
|-----------|---------|-----------------|--------|-------------------|-----------------|-------------|-----------------------|--------------------|
| | | mm | inch | | | | | |
| 4157100 | 40 EWRI | 0 – 25 | 0 – 1" | carbide | 0.001 / .00005" | 2 | 2 | 0.6 |
| 4157101 | 40 EWRI | 25 – 50 | 1 – 2" | carbide | 0.001 / .00005" | 2 | 2 | 0.6 |
| 4157102 | 40 EWRI | 50 – 75 | 2 – 3" | carbide | 0.001 / .00005" | 3 | 3 | 0.6 |
| 4157103 | 40 EWRI | 75 – 100 | 3 – 4" | carbide | 0.001 / .00005" | 3 | 3 | 0.6 |
| 4157104 | 40 EWRI | 100 – 125 | 4 – 5" | carbide | 0.001 / .00005" | 6 | 3 | 0.6 |
| 4157105 | 40 EWRI | 125 – 150 | 5 – 6" | carbide | 0.001 / .00005" | 6 | 3 | 0.6 |
| 4157106 | 40 EWRI | 150 – 175 | 6 – 7" | carbide | 0.001 / .00005" | 7 | 4 | 0.6 |
| 4157107 | 40 EWRI | 175 – 200 | 7 – 8" | carbide | 0.001 / .00005" | 7 | 4 | 0.6 |
| 4157115 | 40 EWRI | 0 – 100 | 0 – 4" | carbide | 0.001 / .00005" | | | |

| Order no. | Spindle thread pitch | Measuring force | Standard | Number of micrometers | Model contact surface | a | b | c |
|-----------|----------------------|-----------------|------------------|-----------------------|-----------------------|-----|-----|-----|
| | | | | | | mm | mm | mm |
| 4157100 | 0.5 | 5 – 10 | Factory standard | | flat | 24 | 9.5 | 32 |
| 4157101 | 0.5 | 5 – 10 | Factory standard | | flat | 36 | 11 | 57 |
| 4157102 | 0.5 | 5 – 10 | Factory standard | | flat | 45 | 13 | 82 |
| 4157103 | 0.5 | 5 – 10 | Factory standard | | flat | 57 | 13 | 107 |
| 4157104 | 0.5 | 5 – 10 | DIN 863-1 | | flat | 73 | 13 | 132 |
| 4157105 | 0.5 | 5 – 10 | DIN 863-1 | | flat | 82 | 13 | 157 |
| 4157106 | 0.5 | 5 – 10 | DIN 863-1 | | flat | 95 | 13 | 182 |
| 4157107 | 0.5 | 5 – 10 | DIN 863-1 | | flat | 106 | 13 | 207 |
| 4157115 | 0.5 | 5 – 10 | Factory standard | 4 | flat | | | |

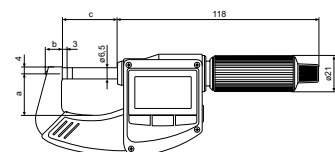

ACCESSORIES

| Order no. | Description | Type |
|-----------|---|---------|
| 4102220 | Receiver for instruments with Integrated Wireless | i-Stick |
| 4102520 | Battery 3 V, CR 2032 | |
| 4158000 | Stand for holding outside micrometers | 41 H |

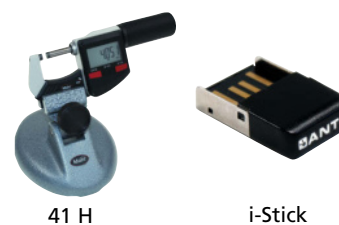

Micromar 40 EWR

Digital micrometer



FUNCTIONS

- RESET (set display to zero)
- ABS (display can be set to zero without losing reference to ORIGIN)
- mm/inch
- ORIGIN (for entering a numerical value)
- LOCK function (key lock)
- TOL (Tolerance and Warning Limits Input)
- HOLD (storage of measured values)
- DATA (data transmission via connection cable)
- Bidirectional data interface (external output and input option of characteristic values as well as setting of individual lock functions by MarCom Software)

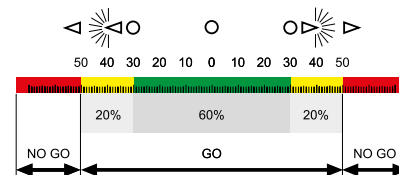

FEATURES

- High contrast digital display
- Stainless spindle is hardened throughout and ground
- Spindle and anvil are carbide-tipped
- Rapid drive
- Ratchet is integrated in the thimble
- Lacquered steel frame, heat insulated
- **Software:** MarCom Professional free download: www.mahr.com/marcom (only for Mahr data cables and wireless systems with USB and RS-232 interface)
- **Digit height:** 10 mm
- **Data interface:** MarConnect (bidirectional), USB, Digimatic
- **Energy supply:** Battery life approx. 2 years
- **Battery type:** CR 2032 (3V Lithium)
- **IP protection category:** IP 65
- **Package contains:** instruction manual, battery, setting standard (measuring range of 25–50 mm), case

TECHNICAL DATA

| Order no. | Type | Measuring range | | Measuring surface | Resolution | Error limit | Parallelism deviation | Flatness deviation |
|-----------|--------|-----------------|------|-------------------|-----------------|-------------|-----------------------|--------------------|
| | | mm | inch | | | | | |
| 4157000 | 40 EWR | 0–25 | 0–1" | carbide | 0.001 / .00005" | 2 | 2 | 0.6 |
| 4157001 | 40 EWR | 25–50 | 1–2" | carbide | 0.001 / .00005" | 2 | 2 | 0.6 |
| 4157002 | 40 EWR | 50–75 | 2–3" | carbide | 0.001 / .00005" | 3 | 3 | 0.6 |
| 4157003 | 40 EWR | 75–100 | 3–4" | carbide | 0.001 / .00005" | 3 | 3 | 0.6 |
| 4157004 | 40 EWR | 100–125 | 4–5" | carbide | 0.001 / .00005" | 6 | 3 | 0.6 |
| 4157005 | 40 EWR | 125–150 | 5–6" | carbide | 0.001 / .00005" | 6 | 3 | 0.6 |
| 4157006 | 40 EWR | 150–175 | 6–7" | carbide | 0.001 / .00005" | 7 | 4 | 0.6 |
| 4157007 | 40 EWR | 175–200 | 7–8" | carbide | 0.001 / .00005" | 7 | 4 | 0.6 |
| 4157015 | 40 EWR | 0–100 | 0–4" | carbide | 0.001 / .00005" | | | |

| Order no. | Spindle thread pitch | Measuring force | Standard | Number of micrometers | Model contact surface | a | b | c |
|-----------|----------------------|-----------------|------------------|-----------------------|-----------------------|-----|-----|-----|
| | | | | | | mm | mm | mm |
| 4157000 | 0.5 | 5–10 | Factory standard | | flat | 24 | 9.5 | 32 |
| 4157001 | 0.5 | 5–10 | Factory standard | | flat | 36 | 11 | 57 |
| 4157002 | 0.5 | 5–10 | Factory standard | | flat | 45 | 13 | 82 |
| 4157003 | 0.5 | 5–10 | Factory standard | | flat | 57 | 13 | 107 |
| 4157004 | 0.5 | 5–10 | DIN 863–1 | | flat | 73 | 13 | 132 |
| 4157005 | 0.5 | 5–10 | DIN 863–1 | | flat | 82 | 13 | 157 |
| 4157006 | 0.5 | 5–10 | DIN 863–1 | | flat | 95 | 13 | 182 |
| 4157007 | 0.5 | 5–10 | DIN 863–1 | | flat | 106 | 13 | 207 |
| 4157015 | 0.5 | 5–10 | Factory standard | 4 | flat | | | |

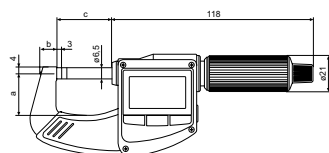

ACCESSORIES

| Order no. | Description | Type |
|-----------|---|-------|
| 4102603 | Data cable USB bidirectional (2 m) | DK-U1 |
| 4102606 | Interface adapter with data cable Digimatic (2 m) | DK-D1 |
| 4158000 | Stand for holding outside micrometers | 41 H |



41 H

Micromar 40 ER

Digital micrometer



FUNCTIONS

- RESET (set display to zero)
- mm/inch
- HOLD (storage of measured values)
- LOCK function (key lock)

FEATURES

- High contrast digital display
- Stainless spindle is hardened throughout and ground
- Spindle and anvil are carbide-tipped
- Rapid drive
- Ratchet is integrated in the thimble
- **Digit height:** 10 mm
- **Battery type:** CR 2032 (3V Lithium)
- **IP protection category:** IP 40
- **Package contains:** instruction manual, battery, case



TECHNICAL DATA

| Order no. | Type | Measuring range | Measuring range inch | Measuring surface | Resolution | Error limit | Spindle thread pitch | Measuring force | Standard | Model contact surface |
|-----------|-------|-----------------|----------------------|-------------------|----------------------------|-------------|----------------------|-----------------|------------------|-----------------------|
| 4157010 | 40 ER | mm 0–25 | inch 0–1" | carbide | mm/inch 0.001 / .00005" | µm 2 | mm 0.5 | N 5–10 | Factory standard | flat |

| Order no. | a | b | c |
|-----------|----------|-----------|----------|
| 4157010 | mm 24 | mm 9.5 | mm 32 |

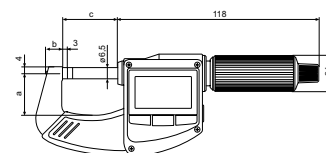

ACCESSORIES

| Order no. | Description | Type |
|-----------|---------------------------------------|------|
| 4102520 | Battery 3 V, CR 2032 | |
| 4158000 | Stand for holding outside micrometers | 41 H |



41 H

Micromar 40 EWR

Digital micrometer



FUNCTIONS

- RESET (set display to zero)
- ABS (display can be set to zero without losing reference to preset)
- mm/inch
- PRESET (for entering a numerical value)
- LOCK function (key lock)
- HOLD (storage of measured values)



FEATURES

- High contrast digital display
- Stainless spindle is hardened throughout and ground
- Spindle and anvil are carbide-tipped
- Rapid drive
- Ratchet is integrated in the thimble
- Lacquered steel frame, heat insulated
- **Digit height:** 10 mm
- **Energy supply:** Battery life approx. 2 years
- **Battery type:** CR 2032 (3V Lithium)
- **IP protection category:** IP 65
- **Package contains:** instruction manual, battery, setting standard (measuring range of 25–50 mm), case

TECHNICAL DATA

| Order no. | Type | Measuring range | Measuring range | Measuring surface | Resolution | Error limit | Spindle thread pitch | Measuring force | Standard | Model contact surface |
|-----------|--------|-----------------|-----------------|-------------------|-----------------|-------------|----------------------|-----------------|------------------|-----------------------|
| | | mm | inch | | mm/inch | µm | mm | N | | |
| 4157011 | 40 EWR | 0–25 | 0–1" | carbide | 0.001 / .00005" | 2 | 0.5 | 5–10 | Factory standard | flat |
| 4157012 | 40 EWR | 25–50 | 1–2" | carbide | 0.001 / .00005" | 2 | 0.5 | 5–10 | Factory standard | flat |
| 4157013 | 40 EWR | 50–75 | 2–3" | carbide | 0.001 / .00005" | 3 | 0.5 | 5–10 | Factory standard | flat |
| 4157014 | 40 EWR | 75–100 | 3–4" | carbide | 0.001 / .00005" | 3 | 0.5 | 5–10 | Factory standard | flat |

| Order no. | a | b | c |
|-----------|----|-----|-----|
| | mm | mm | mm |
| 4157011 | 24 | 9.5 | 32 |
| 4157012 | 36 | 11 | 57 |
| 4157013 | 45 | 13 | 82 |
| 4157014 | 57 | 13 | 107 |

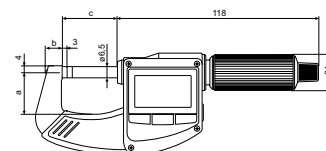

ACCESSORIES

| Order no. | Description | Type |
|-----------|---------------------------------------|------|
| 4158000 | Stand for holding outside micrometers | 41 H |



41 H

Micromar 40 EWRI-L

Digital micrometer



FUNCTIONS

- RESET (set display to zero)
- ABS (display can be set to zero without losing reference to ORIGIN)
- mm/inch
- ORIGIN (for entering a numerical value)
- LOCK function (key lock)
- TOL (Tolerance and Warning Limits Input)
- HOLD (storage of measured values)
- DATA (data transmission)
- Bidirectional data interface (external output and input option of characteristic values as well as setting of individual lock functions by MarCom Software)



Applications:

- Avoiding workpiece damage: The non-rotating spindle contacts the surface without any friction, which prevents scratch marks on sensitive and finely machined surfaces.
- Ideal for measuring thin metal foils without twisting and bending them.
- Thread flank measurement by using thread wires: Both wire holders always remain in the engaged position with the non-rotating spindle.

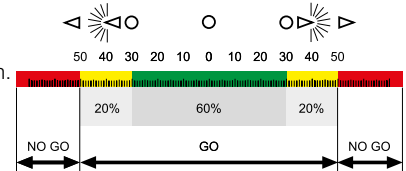

FEATURES

- High contrast digital display
- Stainless spindle is hardened throughout and ground
- Spindle and anvil are carbide-tipped
- Quick drive
- Sliding spindle
- Ratchet is integrated in the thimble
- Lacquered steel frame, heat insulated
- **Software:** MarCom Professional free download: www.mahr.com/marcom (only for Mahr data cables and wireless systems with USB and RS-232 interface)
- **Digit height:** 10 mm
- **Data interface:** Integrated Wireless
- **Energy supply:** Battery life approx. 2 years (approx. 0.5 in wireless mode)
- **Battery type:** CR 2032 (3V Lithium)
- **IP protection category:** IP 65
- **Package contains:** instruction manual, battery, setting standard (measuring range of 25–50 mm), case

TECHNICAL DATA

| Order no. | Type | Measuring range | Measuring range | Measuring surface | Resolution | Error limit | Parallelism deviation | Flatness deviation |
|-----------|-----------|-----------------|-----------------|-------------------|-----------------|-------------|-----------------------|--------------------|
| | | mm | inch | | mm/inch | µm | µm | µm |
| 4157120 | 40 EWRI-L | 0–25 | 0–1" | carbide | 0.001 / .00005" | 2 | 2 | 0.6 |
| 4157121 | 40 EWRI-L | 25–50 | 1–2" | carbide | 0.001 / .00005" | 2 | 2 | 0.6 |
| 4157122 | 40 EWRI-L | 50–75 | 2–3" | carbide | 0.001 / .00005" | 3 | 3 | 0.6 |
| 4157123 | 40 EWRI-L | 75–100 | 3–4" | carbide | 0.001 / .00005" | 3 | 3 | 0.6 |
| 4157410 | 40 EWRI-L | 0–100 | 0–4" | carbide | 0.001 / .00005" | | | |

| Order no. | Spindle thread pitch | Measuring force | Standard | Number of micrometers | Model contact surface | a | b | c |
|-----------|----------------------|-----------------|------------------|-----------------------|-----------------------|----|-----|-----|
| | mm | N | | | | mm | mm | mm |
| 4157120 | 5 | 5–10 | Factory standard | | flat | 24 | 9.5 | 32 |
| 4157121 | 5 | 5–10 | Factory standard | | flat | 36 | 11 | 57 |
| 4157122 | 5 | 5–10 | Factory standard | | flat | 45 | 13 | 82 |
| 4157123 | 5 | 5–10 | Factory standard | | flat | 57 | 13 | 107 |
| 4157410 | 5 | 5–10 | Factory standard | 4 | flat | | | |

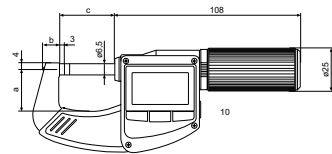

ACCESSORIES

| Order no. | Description | Type |
|-----------|---|---------|
| 4102220 | Receiver for instruments with Integrated Wireless | i-Stick |
| 4158000 | Stand for holding outside micrometers | 41 H |



41 H



i-Stick

Micromar 40 EWR-L

Digital micrometers



FUNCTIONS

- RESET (set display to zero)
- ABS (display can be set to zero without losing reference to ORIGIN)
- mm/inch
- ORIGIN (for entering a numerical value)
- LOCK function (key lock)
- TOL (Tolerance and Warning Limits Input)
- HOLD (storage of measured values)
- DATA (data transmission via connection cable)
- Bidirectional data interface (external output and input option of characteristic values as well as setting of individual lock functions by MarCom Software)



Applications:

- Avoiding workpiece damage: The non-rotating spindle contacts the surface without any friction, which prevents scratch marks on sensitive and finely machined surfaces.
- Ideal for measuring thin metal foils without twisting and bending them.
- Thread flank measurement by using thread wires: Both wire holders always remain in the engaged position with the non-rotating spindle.

FEATURES

- High contrast digital display
- Stainless spindle is hardened throughout and ground
- Spindle and anvil are carbide-tipped
- Quick drive
- Sliding spindle
- Ratchet is integrated in the thimble
- Lacquered steel frame, heat insulated
- **Software:** MarCom Professional free download: www.mahr.com/marcom (only for Mahr data cables and wireless systems with USB and RS-232 interface)
- **Digit height:** 10 mm
- **Data interface:** MarConnect (bidirectional), USB, Digimatic
- **Energy supply:** Battery life approx. 2 years
- **Battery type:** CR 2032 (3V Lithium)
- **IP protection category:** IP 65
- **Package contains:** battery, instruction manual, setting standard (measuring range of 25–50 mm), case

TECHNICAL DATA

| Order no. | Type | Measuring range | Measuring range | Measuring surface | Resolution | Error limit | Parallelism deviation | Flatness deviation |
|-----------|----------|-----------------|-----------------|-------------------|-----------------|-------------|-----------------------|--------------------|
| | | mm | inch | | mm/inch | µm | µm | µm |
| 4157020 | 40 EWR-L | 0–25 | 0–1" | carbide | 0.001 / .00005" | 2 | 2 | 0.6 |
| 4157021 | 40 EWR-L | 25–50 | 1–2" | carbide | 0.001 / .00005" | 2 | 2 | 0.6 |
| 4157022 | 40 EWR-L | 50–75 | 2–3" | carbide | 0.001 / .00005" | 3 | 3 | 0.6 |
| 4157023 | 40 EWR-L | 75–100 | 3–4" | carbide | 0.001 / .00005" | 3 | 3 | 0.6 |
| 4157400 | 40 EWR-L | 0–100 | 0–4" | carbide | 0.001 / .00005" | | | |

| Order no. | Spindle thread pitch | Measuring force | Standard | Number of micrometers | Model contact surface | a | b | c |
|-----------|----------------------|-----------------|------------------|-----------------------|-----------------------|----|-----|-----|
| | mm | N | | | | mm | mm | mm |
| 4157020 | 5 | 5–10 | Factory standard | | flat | 24 | 9.5 | 32 |
| 4157021 | 5 | 5–10 | Factory standard | | flat | 36 | 11 | 57 |
| 4157022 | 5 | 5–10 | Factory standard | | flat | 45 | 13 | 82 |
| 4157023 | 5 | 5–10 | Factory standard | | flat | 57 | 13 | 107 |
| 4157400 | 5 | 5–10 | Factory standard | 4 | flat | | | |

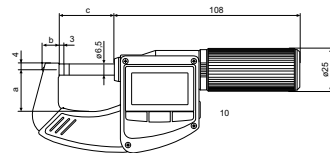

ACCESSORIES

| Order no. | Description | Type |
|-----------|---|-------|
| 4102603 | Data cable USB bidirectional (2 m) | DK-U1 |
| 4102606 | Interface adapter with data cable Digimatic (2 m) | DK-D1 |
| 4158000 | Stand for holding outside micrometers | 41 H |



41 H

Micromar 40 A / 40 SA

Micrometer

FEATURES

- Operating and display units with satin chrome finish
- Hard lacquered steel frame
- Spindle and anvil made of hardened steel, carbide-tipped
- Heat insulators
- Rapid drive with integrated ratchet
- Locking device
- **Package contains:** setting standard (measuring range of 25–50 mm), instruction manual, case



TECHNICAL DATA

| Order no. | Type | Measuring range | | Readings | | Error limit | | Spindle | |
|-----------|-------|-----------------|------|----------|--------|---------------|---------|---------|-----|
| | | mm | inch | mm | inch | μm | inch | inch | mm |
| 4134000 | 40 A | 0–25 | | 0.01 | | 4 | | | 0.5 |
| 4134001 | 40 A | 25–50 | | 0.01 | | 4 | | | 0.5 |
| 4134002 | 40 A | 50–75 | | 0.01 | | 5 | | | 0.5 |
| 4134003 | 40 A | 75–100 | | 0.01 | | 5 | | | 0.5 |
| 4134004 | 40 A | 100–125 | | 0.01 | | 6 | | | 0.5 |
| 4134005 | 40 A | 125–150 | | 0.01 | | 6 | | | 0.5 |
| 4134006 | 40 A | 150–175 | | 0.01 | | 7 | | | 0.5 |
| 4134007 | 40 A | 175–200 | | 0.01 | | 7 | | | 0.5 |
| 4134050 | 40 SA | 0–100 | | 0.01 | | | | | 0.5 |
| 4134051 | 40 SA | 100–200 | | 0.01 | | | | | 0.5 |
| 4134900 | 40 A | | 0–1" | | 0.0001 | | 0.00016 | 0.025 | |
| 4134901 | 40 A | | 1–2" | | 0.0001 | | 0.00016 | 0.025 | |
| 4134902 | 40 A | | 2–3" | | 0.0001 | | 0.0002 | 0.025 | |
| 4134903 | 40 A | | 3–4" | | 0.0001 | | 0.0002 | 0.025 | |
| 4134904 | 40 A | | 4–5" | | 0.0001 | | 0.00024 | 0.025 | |
| 4134905 | 40 A | | 5–6" | | 0.0001 | | 0.00024 | 0.025 | |
| 4134906 | 40 A | | 6–7" | | 0.0001 | | 0.00028 | 0.025 | |
| 4134907 | 40 A | | 7–8" | | 0.0001 | | 0.00028 | 0.025 | |
| 4134960 | 40 SA | | 0–4" | | 0.0001 | | | 0.025 | |
| 4134961 | 40 SA | | 4–8" | | 0.0001 | | | 0.025 | |

| Order no. | Standard | Number of micrometers | Model contact surface | Dimensions | | |
|-----------|------------------|-----------------------|-----------------------|------------|-------|----|
| | | | | a | b | c |
| | | | | mm | mm | mm |
| 4134000 | DIN 863–1 | | flat | 31 | 25.5 | 7 |
| 4134001 | DIN 863–1 | | flat | 56 | 34.5 | 12 |
| 4134002 | DIN 863–1 | | flat | 81 | 47.5 | 12 |
| 4134003 | DIN 863–1 | | flat | 106 | 58.5 | 13 |
| 4134004 | DIN 863–1 | | flat | 131 | 71.5 | 13 |
| 4134005 | DIN 863–1 | | flat | 156 | 83.5 | 13 |
| 4134006 | DIN 863–1 | | flat | 182 | 95.5 | 13 |
| 4134007 | DIN 863–1 | | flat | 207 | 108.5 | 13 |
| 4134050 | DIN 863–1 | 4 | flat | | | |
| 4134051 | DIN 863–1 | 4 | flat | | | |
| 4134900 | Factory standard | | flat | 31 | 25.5 | 7 |
| 4134901 | Factory standard | | flat | 56 | 34.5 | 12 |
| 4134902 | Factory standard | | flat | 81 | 47.5 | 12 |
| 4134903 | Factory standard | | flat | 106 | 58.5 | 13 |
| 4134904 | Factory standard | | flat | 131 | 71.5 | 13 |
| 4134905 | Factory standard | | flat | 156 | 83.5 | 13 |
| 4134906 | Factory standard | | flat | 182 | 95.5 | 13 |
| 4134907 | Factory standard | | flat | 207 | 108.5 | 13 |
| 4134960 | Factory standard | | flat | | | |
| 4134961 | Factory standard | | flat | | | |

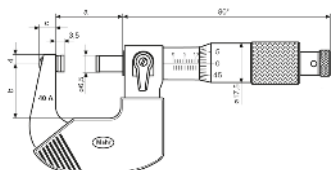

ACCESSORIES

| Order no. | Description | Type |
|-----------|---------------------------------------|------|
| 4158000 | Stand for holding outside micrometers | 41 H |



41 H

Micromar 40 F / 40 FC

Micrometer with integrated dial comparator

FEATURES

- Operating and display units with satin chrome finish
- Dial comparator is integrated in frame
- Adjustable tolerance markers
- Chrome plated steel frame, heat insulated
- Retraction of the movable anvil ensures maximum wear resistance
- Spindle and anvil are carbide-tipped
- Stainless spindle is hardened throughout and ground
- Locking device
- Constant measuring force
- **Package contains:** instruction manual, case



Application:

- Quick check of diameter of cylindrical parts (shafts, bolts, shanks)
- Thickness and length measurements
- Particularly suitable for exact series components

TECHNICAL DATA

| Order no. | | 4150000 | 4150001 | 4150200 | 4150201 |
|--|----|---------|---------|------------------|---------|
| Type | | 40 F | | 40 FC | |
| Measuring range | mm | 0 –25 | 25 –50 | 0 –25 | 25 –50 |
| Measuring surface | | carbide | | ceramic | |
| Readings | | | | 0.01 | |
| Error limit | µm | | | 2 | |
| Parallelism deviation | µm | | | 1 | |
| Flatness deviation | µm | | | 0.2 | |
| Spindle thread pitch | mm | | | 0.5 | |
| Measuring force | N | | | 9 | |
| Standard | | | | Factory standard | |
| Model contact surface | | | | flat | |
| Measuring range, dial comparator (measuring screw) | µm | | | ± 65 | |
| Scale graduation value | µm | | | 1 | |
| Error limit G _e | µm | | | 1 | |

| Order no. | | 4150900 | 4150901 |
|--|------|---------|------------------|
| Type | | 40 F | |
| Measuring range | inch | 0 –1" | 1 –2" |
| Readings | inch | | 0.0001 |
| Error limit | inch | | 0.00008 |
| Parallelism deviation | µm | | 1 |
| Flatness deviation | µm | | 0.2 |
| Spindle pitch | inch | | 0.025 |
| Measuring force | N | | 9 |
| Standard | | | Factory standard |
| Model contact surface | | | flat |
| Measuring range dial comparator (Micrometer screw) | inch | | ± .0025" |
| Scale graduation value | inch | | 0.00005 |
| Error limit G _e | inch | | 0.00005 |

| Order no. | a | b | c | d | e |
|-----------|-----|-----|----|----|----|
| | mm | mm | mm | mm | mm |
| 4150000 | 149 | 100 | 16 | 71 | 32 |
| 4150001 | 174 | 125 | 30 | 85 | 56 |
| 4150200 | 149 | 100 | 16 | 71 | 32 |
| 4150201 | 174 | 125 | 30 | 85 | 56 |
| 4150900 | 149 | 100 | 16 | 71 | 32 |
| 4150901 | 174 | 125 | 30 | 85 | 56 |

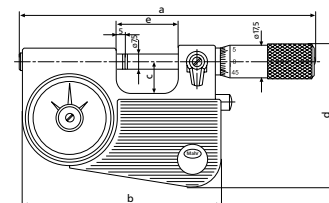

ACCESSORIES

| Order no. | Description | Type |
|-----------|---------------------------------------|------|
| 4158000 | Stand for holding outside micrometers | 41 H |
| 4159400 | Setting gage, flat (25 mm) | 43 A |



41 H

Micromar 40 T

Micrometer with integrated dial comparator

DIN
863-3

FEATURES

- Operating and display units with satin chrome finish
- Retraction of the movable anvil ensures maximum wear resistance
- Constant measuring force
- Stainless spindle is hardened throughout and ground
- Spindle and anvil are carbide-tipped
- Locking device
- **Package contains:** instruction manual, case



Application:

- Quick check of diameter of cylindrical parts (shafts, bolts, shanks)
- Thickness and length measurements
- Particularly suitable for exact series components

TECHNICAL DATA

| Order no. | 4154000 | 4154001 | 4154002 | 4154003 | 4154004 |
|--|----------------|---------|---------|----------|-----------|
| Type | | | | | 40 T |
| Measuring range | mm | 0 – 25 | 25 – 50 | 50 – 100 | 100 – 150 |
| Readings | | | | | 0.01 |
| Error limit | μm | | | | 2 |
| Parallelism deviation | μm | | | | 2 |
| Flatness deviation | μm | | | | 0.2 |
| Spindle thread pitch | mm | | | | 0.5 |
| Measuring force | N | 6.5 | | 7.5 | |
| Standard | DIN 863-3 | | | | |
| Indicating instrument (included in package) | Millimess 1003 | | | | |
| Model contact surface | flat | | | | |
| Measuring range, dial comparator (measuring screw) | μm | ± 50 | | | |
| Scale graduation value | μm | 1 | | | |
| Error limit G_e | μm | 1 | | | |

| Order no. | a | b | c | d | e |
|-----------|-----|-----|-----|----|----|
| | mm | mm | mm | mm | mm |
| 4154000 | 27 | 28 | 4 | 11 | 8 |
| 4154001 | 52 | 40 | 4 | 11 | 8 |
| 4154002 | 76 | 65 | 5.5 | 30 | 8 |
| 4154003 | 127 | 87 | 5.5 | 30 | 8 |
| 4154004 | 177 | 112 | 5.5 | 30 | 8 |

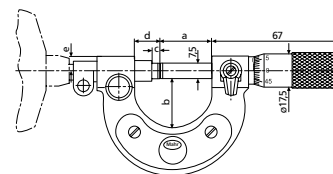

ACCESSORIES

| Order no. | Description | Type |
|-----------|---------------------------------------|------|
| 4158000 | Stand for holding outside micrometers | 41 H |
| 4159400 | Setting gage, flat (25 mm) | 43 A |
| 4159401 | Setting gage, flat (50 mm) | 43 A |
| 4159402 | Setting gage, flat (75 mm) | 43 A |
| 4159403 | Setting gage, flat (100 mm) | 43 A |
| 4159404 | Setting gage, flat (125 mm) | 43 A |
| 4159405 | Setting gage, flat (150 mm) | 43 A |
| 4159406 | Setting gage, flat (175 mm) | 43 A |



41 H

Micromar 40 TS

Precision bench micrometer

DIN
863-3

FEATURES

- Operating and display units with satin chrome finish
- Rugged steel frame, can be inclined up to 45° from the sturdy base
- Retraction of the movable anvil ensures maximum wear resistance
- Height adjustable stop
- Constant measuring force
- Stainless spindle is hardened throughout and ground
- Spindle and anvil are carbide-tipped
- Locking device
- **Package contains:**
dial comparator 1003 Z,
instruction manual

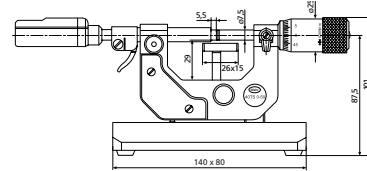

Application:

- Quick check of diameter of cylindrical parts (shafts, bolts, shanks)
- Thickness and length measurements
- Particularly suitable for exact series components

TECHNICAL DATA

| Order no. | 4154030 | 4154031 |
|--|---------|-----------------|
| Type | | 40 TS |
| Measuring range | mm | 0 –50 |
| Readings | | 0.005 |
| Error limit | µm | 2 |
| Parallelism deviation | µm | 2 |
| Flatness deviation | µm | 0.2 |
| Spindle thread pitch | mm | 0.5 |
| Measuring force | N | 6.5 |
| Standard | | DIN 863–3 |
| Indicating instrument (included in package) | | Millimess 1003 |
| Model contact surface | | Without readout |
| Measuring range, dial comparator (measuring screw) | µm | ± 50 |
| Scale graduation value | µm | 1 |
| Error limit G _e | µm | 1 |

| Order no. | 4154930 | 4154931 |
|--|---------|------------------|
| Type | | 40 TS |
| Measuring range | inch | 0 –2" |
| Readings | inch | 0.00025 |
| Error limit | inch | 0.00008 |
| Spindle pitch | inch | 0.025 |
| Measuring force | N | 6.5 |
| Indicating instrument (included in package) | | Millimess 1003 Z |
| Model contact surface | | Without readout |
| Measuring range dial comparator (Micrometer screw) | inch | ± .0025" |
| Scale graduation value | inch | 0.00005 |
| Error limit G _e | inch | 0.00005 |

ACCESSORIES

| Order no. | Description | Type |
|-----------|---------------------------------------|---------|
| 4335000 | Millimess 0.5 µm, ± 25 µm | 1002 |
| 4334000 | Millimess 1 µm, ± 50 µm | 1003 |
| 4333000 | Millimess 5 µm, ± 130 µm | 1004 |
| 4337624 | Digital indicator, 0.0005 mm, 12.5 mm | 1086 Ri |
| 4337620 | Digital indicator, 0.0005 mm, 12.5 mm | 1086 R |
| 4337663 | Digital indicator, 0.0005 mm, 12.5 mm | 1087 Ri |
| 4337660 | Digital indicator, 0.0005 mm, 12.5 mm | 1087 R |
| 4154035 | Wooden case | |
| 4159400 | Setting gage, flat (25 mm) | 43 A |



1003



1086 Ri



1087 Ri



1087 R

Micromar 40 EWri-V

Digital micrometer



FUNCTIONS

- RESET (set display to zero)
- ABS (display can be set to zero without losing reference to ORIGIN)
- mm/inch
- ORIGIN (for entering a numerical value)
- LOCK function (key lock)
- TOL (Tolerance and Warning Limits Input)
- HOLD (storage of measured values)
- DATA (data transmission)
- Bidirectional data interface (external output and input option of characteristic values as well as setting of individual lock functions by MarCom Software)

FEATURES

- High contrast digital display
- Stainless spindle is hardened throughout and ground
- With mounting bores for measuring anvils with a shaft \varnothing 3.5 mm
- Quick drive
- Sliding spindle
- Ratchet is integrated in the thimble
- Lacquered steel frame, heat insulated
- **Software:** MarCom Professional free download: www.mahr.com/marcom (only for Mahr data cables and wireless systems with USB and RS-232 interface)
- **Digit height:** 10 mm
- **Data interface:** Integrated Wireless
- **Energy supply:** Battery life approx. 3 years (approx. 0.5 in wireless mode)
- **Battery type:** CR 2032 (3V Lithium)
- **IP protection category:** IP 65
- **Package contents:** 1 pair each of the following measuring anvils
 - 40 Ef flat \varnothing 6.5 mm
 - 40 Ea offset \varnothing 2 x 4 mm
 - 40 Et plate \varnothing 11.3 mm
 - 40 Eb spherical R=5 mm
 - 40 Ep tapered 60° \varnothing 0.3 – 5.5 mm
 - 40 Es blade 0.75 x 4 mm
- **Package contains:** instruction manual, battery, case



Applications:

- Universal adjustment to different workpiece and measurement situations using individual interchangeable measuring anvils.
- Thread flanks and spherical measuring anvils (optional accessories) can also be used.

TECHNICAL DATA

| Order no. | Type | Measuring range | Measuring range | Resolution | Error limit | Spindle thread pitch | Measuring force | Standard | Model contact surface | Accessories |
|-----------|-----------|-----------------|-----------------|----------------------------|--------------|----------------------|-----------------|-----------|-----------------------|-------------|
| 4157150 | 40 EWri-V | 0–25 | 0–1" | mm/inch 0.001 / .00005" | μ m 4 | mm 5 | N 5–10 | DIN 863–3 | 3.5 mm bore | • |

| Order no. | a | b | c | Mounting hole |
|-----------|----------|------------|----------|--|
| 4157150 | mm 32 | mm 11.5 | mm 57 | For measuring anvils with a shaft diameter 3.5 x 15.5 mm |

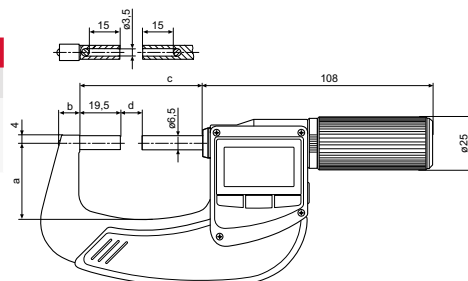

ACCESSORIES

| Order no. | Description | Type |
|-----------|---|---------|
| 4102220 | Receiver for instruments with Integrated Wireless | i-Stick |
| 4151794 | Plane measuring anvil (6.5 mm) | 40 Ef |
| 4151795 | Measuring anvil with reduced measuring surface (2.3 x 2 mm) | 40 Ea |
| 4151796 | Measuring anvil plate (11.3 mm) | 40 Et |
| 4151797 | Measuring anvil with convex measuring surface (6.5 mm) | 40 Er |
| 4151798 | Measuring anvil with tip (60°) | 40 Ep |
| 4151799 | Measuring anvil with blade (0.45 mm x 4) | 40 Es |
| 4158000 | Stand for holding outside micrometers | 41 H |
| 4173210 | Anvil flat, hardened steel, \varnothing 7.5 mm | 40 Za |
| 4511190 | Anvil flat, carbide tipped, \varnothing 7.5 mm | 40 Za |

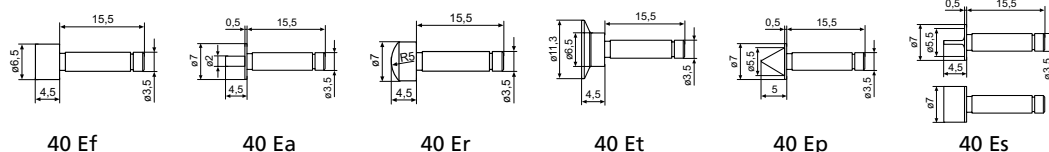

41 H



i-Stick

Micromar 40 EWR-V

Digital micrometer



FUNCTIONS

- RESET (set display to zero)
- ABS (display can be set to zero without losing reference to ORIGIN)
- mm/inch
- ORIGIN (for entering a numerical value)
- LOCK function (key lock)
- TOL (Tolerance and Warning Limits Input)
- HOLD (storage of measured values)
- DATA (data transmission)
- Bidirectional data interface (external output and input option of characteristic values as well as setting of individual lock functions by MarCom Software)

FEATURES

- High contrast digital display
- Stainless spindle is hardened throughout and ground
- With mounting bores for measuring anvils with a shaft \varnothing 3.5 mm
- Quick drive
- Sliding spindle
- Ratchet is integrated in the thimble
- Lacquered steel frame, heat insulated
- **Software:** MarCom Professional free download: www.mahr.com/marcom (only for Mahr data cables and wireless systems with USB and RS-232 interface)
- **Digit height:** 10 mm
- **Data interface:** MarConnect (bidirectional), USB, Digimatic
- **Energy supply:** Battery life approx. 3 years
- **Battery type:** CR 2032 (3V Lithium)
- **IP protection category:** IP 65
- **Package contents:** 1 pair each of the following measuring anvils:
 - 40 Ef flat \varnothing 6.5 mm
 - 40 Ea offset 2×4 mm
 - 40 Et plate \varnothing 11.3 mm
 - 40 Eb spherical $R=5$ mm
 - 40 Ep tapered $60^\circ \varnothing 0.3 - 5.5$ mm
 - 40 Es blade 0.75×4 mm
- **Package contains:** instruction manual, battery, case



Applications:

- Universal adjustment to different workpiece and measurement situations using individual interchangeable measuring anvils.
- Thread flanks and spherical measuring anvils (optional accessories) can also be used.

TECHNICAL DATA

| Order no. | Type | Measuring range | Measuring range | Resolution | Error limit | Spindle thread pitch | Measuring force | Standard | Model contact surface | Accessories |
|-----------|----------|-----------------|-----------------|-----------------|---------------|----------------------|-----------------|-----------|-----------------------|-------------|
| | | mm | inch | mm/inch | μm | mm | N | | | |
| 4157050 | 40 EWR-V | 0–25 | 0–1" | 0.001 / .00005" | 4 | 5 | 5–10 | DIN 863–3 | 3.5 mm bore | • |

| Order no. | a | b | c | Mounting hole |
|-----------|----|------|----|---|
| | mm | mm | mm | |
| 4157050 | 32 | 11.5 | 57 | For measuring anvils with a shaft diameter 3.5×15.5 mm |

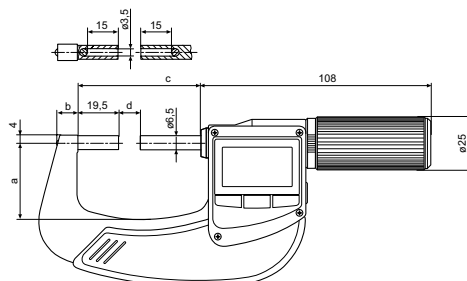

ACCESSORIES

| Order no. | Description | Type |
|-----------|---|-------|
| 4102603 | Data cable USB bidirectional (2 m) | DK-U1 |
| 4102606 | Interface adapter with data cable Digimatic (2 m) | DK-D1 |
| 4151794 | Plane measuring anvil (6.5 mm) | 40 Ef |
| 4151795 | Measuring anvil with reduced measuring surface (2.3 x 2 mm) | 40 Ea |
| 4151796 | Measuring anvil plate (11.3 mm) | 40 Et |
| 4151797 | Measuring anvil with convex measuring surface (6.5 mm) | 40 Er |
| 4151798 | Measuring anvil with tip (60°) | 40 Ep |
| 4151799 | Measuring anvil with blade (0.45 mm x 4) | 40 Es |
| 4158000 | Stand for holding outside micrometers | 41 H |
| 4173210 | Anvil flat, hardened steel, \varnothing 7.5 mm | 40 Za |
| 4511190 | Anvil flat, carbide tipped, \varnothing 7.5 mm | 40 Za |

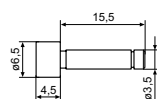

40 Ef

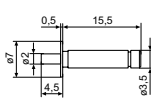

40 Ea

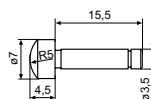

40 Er

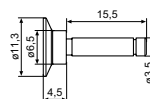

40 Et

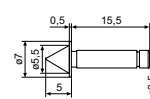

40 Ep

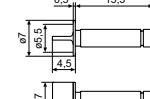

40 Es



41 H



i-Stick

Micromar 40 EWri-V

Digital micrometer



FUNCTIONS

- RESET (set display to zero)
- ABS (display can be set to zero without losing reference to ORIGIN)
- mm/inch
- ORIGIN (for entering a numerical value)
- LOCK function (key lock)
- TOL (Tolerance and Warning Limits Input)
- HOLD (storage of measured values)
- DATA (data transmission)
- Bidirectional data interface (external output and input option of characteristic values as well as setting of individual lock functions by MarCom Software)



Application:

- For measuring thread flanks and gear diameters using quick-change measuring anvils.



FEATURES

- With mounting bores for measuring anvils with a shaft \varnothing 3.5 mm
- High contrast digital display
- Stainless spindle is hardened throughout and ground
- Quick drive
- Sliding spindle
- Ratchet is integrated in the thimble
- Lacquered steel frame, heat insulated
- **Software:** MarCom Professional free download: www.mahr.com/marcom (only for Mahr data cables and wireless systems with USB and RS-232 interface)
- **Digit height:** 10 mm
- **Data interface:** Integrated Wireless
- **Energy supply:** Battery life approx. 2 years
- **Battery type:** CR 2032 (3V Lithium)
- **IP protection category:** IP 65
- **Package contains:** instruction manual, battery, case

TECHNICAL DATA

| Order no. | Type | Measuring range | Measuring range | Resolution | Error limit | Spindle thread pitch | Measuring force | Standard | Model contact surface |
|-----------|-----------|-----------------|-----------------|-----------------|-------------|----------------------|-----------------|-----------|-----------------------|
| | | mm | inch | mm/inch | μ m | mm | N | | |
| 4157145 | 40 EWri-V | 0 – 25 | 0 – 1" | 0.001 / .00005" | 4 | 5 | 5 – 10 | DIN 863–3 | 3.5 mm bore |
| 4157146 | 40 EWri-V | 25 – 50 | 1 – 2" | 0.001 / .00005" | 4 | 5 | 5 – 10 | DIN 863–3 | 3.5 mm bore |
| 4157147 | 40 EWri-V | 50 – 75 | 2 – 3" | 0.001 / .00005" | 5 | 5 | 5 – 10 | DIN 863–3 | 3.5 mm bore |
| 4157148 | 40 EWri-V | 75 – 100 | 3 – 4" | 0.001 / .00005" | 5 | 5 | 5 – 10 | DIN 863–3 | 3.5 mm bore |

| Order no. | a | b | c | Mounting hole |
|-----------|----|------|-------|--|
| | mm | mm | mm | |
| 4157145 | 32 | 11.5 | 57 | For measuring anvils with a shaft diameter 3.5 x 15.5 mm |
| 4157146 | 44 | 13.5 | 82 | For measuring anvils with a shaft diameter 3.5 x 15.5 mm |
| 4157147 | 57 | 15.5 | 107 | For measuring anvils with a shaft diameter 3.5 x 15.5 mm |
| 4157148 | 73 | 17 | 132.5 | For measuring anvils with a shaft diameter 3.5 x 15.5 mm |

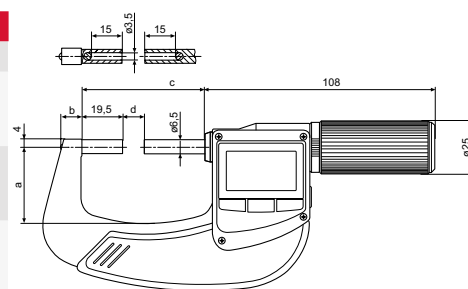

ACCESSORIES

| Order no. | Description | Type |
|-----------|---|---------|
| 4102220 | Receiver for instruments with Integrated Wireless | i-Stick |
| 4158000 | Stand for holding outside micrometers | 41 H |
| 4173210 | Anvil flat, hardened steel, \varnothing 7.5 mm | 40 Za |
| 4511190 | Anvil flat, carbide tipped, \varnothing 7.5 mm | 40 Za |



41 H



i-Stick

Micromar 40 EWR-V

Digital micrometer



FUNCTIONS

- RESET (set display to zero)
- ABS (display can be set to zero without losing reference to ORIGIN)
- mm/inch
- ORIGIN (for entering a numerical value)
- LOCK function (key lock)
- TOL (Tolerance and Warning Limits Input)
- HOLD (storage of measured values)
- DATA (data transmission)
- Bidirectional data interface (external output and input option of characteristic values as well as setting of individual lock functions by MarCom Software)



Application:

- For measuring thread flanks and gear diameters using quick-change measuring anvils.



FEATURES

- With mounting bores for measuring anvils with a shaft \varnothing 3.5 mm
- High contrast digital display
- Stainless spindle is hardened throughout and ground
- Quick drive
- Sliding spindle
- Ratchet is integrated in the thimble
- Lacquered steel frame, heat insulated
- **Software:** MarCom Professional free download: www.mahr.com/marcom (only for Mahr data cables and wireless systems with USB and RS-232 interface)
- **Digit height:** 10 mm
- **Data interface:** MarConnect (bidirectional), USB, Digimatic
- **Energy supply:** Battery life approx. 2 years
- **Battery type:** CR 2032 (3V Lithium)
- **IP protection category:** IP 65
- **Package contains:** instruction manual, battery, case

TECHNICAL DATA

| Order no. | Type | Measuring range | Measuring range | Resolution | Error limit | Spindle thread pitch | Measuring force | Standard | Model contact surface |
|-----------|----------|-----------------|-----------------|-----------------|---------------|----------------------|-----------------|-----------|-----------------------|
| | | mm | inch | mm/inch | μm | mm | N | | |
| 4157045 | 40 EWR-V | 0–25 | 0–1" | 0.001 / .00005" | 4 | 5 | 5–10 | DIN 863–3 | 3.5 mm bore |
| 4157046 | 40 EWR-V | 25–50 | 1–2" | 0.001 / .00005" | 4 | 5 | 5–10 | DIN 863–3 | 3.5 mm bore |
| 4157047 | 40 EWR-V | 50–75 | 2–3" | 0.001 / .00005" | 5 | 5 | 5–10 | DIN 863–3 | 3.5 mm bore |
| 4157048 | 40 EWR-V | 75–100 | 3–4" | 0.001 / .00005" | 5 | 5 | 5–10 | DIN 863–3 | 3.5 mm bore |

| Order no. | a | b | c | Mounting hole |
|-----------|----|------|-------|--|
| | mm | mm | mm | |
| 4157045 | 32 | 11.5 | 57 | For measuring anvils with a shaft diameter 3.5 x 15.5 mm |
| 4157046 | 44 | 13.5 | 82 | For measuring anvils with a shaft diameter 3.5 x 15.5 mm |
| 4157047 | 57 | 15.5 | 107 | For measuring anvils with a shaft diameter 3.5 x 15.5 mm |
| 4157048 | 73 | 17 | 132.5 | For measuring anvils with a shaft diameter 3.5 x 15.5 mm |

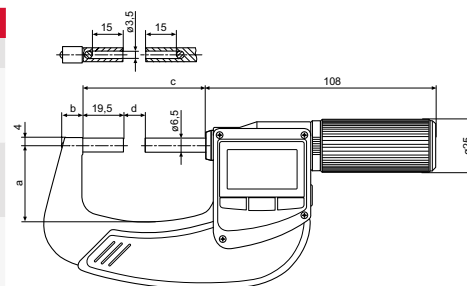

ACCESSORIES

| Order no. | Description | Type |
|-----------|---|-------|
| 4102603 | Data cable USB bidirectional (2 m) | DK-U1 |
| 4102606 | Interface adapter with data cable Digimatic (2 m) | DK-D1 |
| 4158000 | Stand for holding outside micrometers | 41 H |
| 4173210 | Anvil flat, hardened steel, \varnothing 7.5 mm | 40 Za |
| 4511190 | Anvil flat, carbide tipped, \varnothing 7.5 mm | 40 Za |



41 H

Micromar tfhread anvils

Digital micrometer

FEATURES

- Wear-resistant special steel, hardened. With cylindrical mounting shank and retainer ring for rotatable mounting in the bore of the measuring spindle and anvil.
- Pair comprises V-anvil and cone.
- With a pitch of 0.2 – 0.45 mm, the V-anvil bridges 3 turns. It should therefore be set with 715 E thread adjustment pins, otherwise with 43 Z setting standards.

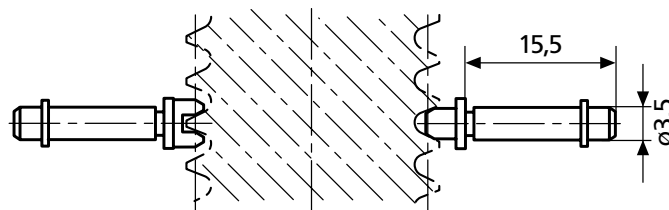

| Thread pitch | Taper Order no. | V-anvil Order no. |
|---|-----------------|-------------------|
| Pitch diameter, external thread Metric 60° | | |
| 0.2 | 4173407 | 4173007 |
| 0.25 | 4173408 | 4173008 |
| 0.3 | 4173409 | 4173009 |
| 0.35 | 4173410 | 4173010 |
| 0.4 | 4173411 | 4173011 |
| 0.45 | 4173412 | 4173012 |
| 0.5 – 0.7 | 4173400 | 4173000 |
| 0.7 – 1 | 4173401 | 4173001 |
| 1.25 – 2 | 4173402 | 4173002 |
| 2 – 3.5 | 4173403 | 4173003 |
| 3.5 – 5 | 4173404 | 4173004 |
| 5 – 7 | 4173405 | 4173005 |
| 7 – 9 | 4173406 | 4173006 |
| Trapezoid 30° | | |
| 1 | 4173650 | 4173250 |
| 1.5 | 4173651 | 4173251 |
| 2 | 4173652 | 4173252 |
| 3 | 4173653 | 4173253 |
| 4 | 4173654 | 4173254 |
| 5 | 4173655 | 4173255 |
| 6 | 4173656 | 4173256 |
| 7 | 4173657 | 4173257 |
| 8 | 4173658 | 4173258 |
| 9 | 4173659 | 4173259 |
| 10 | 4173660 | 4173260 |
| 12 | 4173661 | 4173261 |
| 14 | 4173662 | 4173262 |
| 16 | 4173663 | 4173263 |
| 18 | 4173664 | 4173264 |
| 20 | 4173665 | 4173265 |

| Thread pitch in TPI | Taper Order no. | V-anvil Order no. |
|--|-----------------|-------------------|
| Pitch diameter, external thread UST 60° | | |
| 60 – 48 | 4173513 | 4173113 |
| 48 – 40 | 4173514 | 4173114 |
| 40 – 32 | 4173515 | 4173115 |
| 32 – 24 | 4173516 | 4173116 |
| 24 – 18 | 4173517 | 4173117 |
| 18 – 14 | 4173518 | 4173118 |
| 14 – 10 | 4173519 | 4173119 |
| 10 – 7 | 4173520 | 4173120 |
| 7 – 4.5 | 4173521 | 4173121 |
| 4.5 – 3 | 4173522 | 4173122 |
| Whitworth 55° | | |
| 40 – 32 | 4173443 | 4173043 |
| 32 – 24 | 4173444 | 4173044 |
| 24 – 18 | 4173445 | 4173045 |
| 18 – 14 | 4173446 | 4173046 |
| 14 – 10 | 4173447 | 4173047 |
| 10 – 7 | 4173448 | 4173048 |
| 7 – 4.5 | 4173449 | 4173049 |
| 4.5 – 3 | 4173450 | 4173050 |
| 3 – 2.5 | 4179409 | 4179408 |

Micromar

Ball contact

FEATURES

- For gear measurement and for special tasks
- Carbide measuring balls
- Cylindrical mounting shank with circlip for mounting in the mounting bore of the micrometer or indicating snap gage

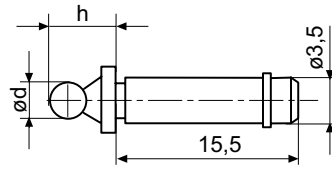

| Order no. | d mm | h mm | Order no. | d mm | h mm | Order no. | d mm | h mm |
|-----------|---------|---------|-----------|---------|---------|-----------|---------|---------|
| 4179150 | 0.5 | 5 | 4179169 | 1.7 | 6.2 | 4170570 | 3.2 | 7.7 |
| 4179151 | 0.551 | 5.1 | 4170553 | 1.75 | 6.3 | 4170566 | 3.25 | 7.8 |
| 4179152 | 0.62 | 5.1 | 4179170 | 1.782 | 6.3 | 4179183 | 3.4 | 7.9 |
| 4179153 | 0.623 | 5.1 | 4179171 | 1.8 | 6.3 | 4170558 | 3.5 | 8 |
| 4179154 | 0.63 | 5.1 | 4179172 | 1.829 | 6.3 | 4179184 | 3.658 | 8.2 |
| 4179155 | 0.722 | 5.2 | 4179173 | 1.9 | 6.4 | 4170571 | 3.7 | 8.2 |
| 4179156 | 0.862 | 5.4 | 4170554 | 2 | 6.5 | 4170559 | 4 | 8.5 |
| 4179157 | 0.895 | 5.4 | 4170568 | 2.032 | 6.5 | 4170560 | 4.5 | 9 |
| 4179158 | 0.965 | 5.5 | 4170569 | 2.2 | 6.7 | 4179185 | 4.835 | 9.3 |
| 4170550 | 1 | 5.5 | 4170564 | 2.25 | 6.8 | 4170561 | 5 | 9.5 |
| 4179159 | 1.1 | 5.6 | 4179174 | 2.284 | 6.8 | 4179186 | 5.25 | 9.8 |
| 4179160 | 1.118 | 5.6 | 4179175 | 2.386 | 6.9 | 4179187 | 5.486 | 10 |
| 4170551 | 1.25 | 5.8 | 4179176 | 2.438 | 6.9 | 4170562 | 5.5 | 10 |
| 4179161 | 1.125 | 5.6 | 4170556 | 2.5 | 7 | 4170563 | 6 | 10.5 |
| 4179162 | 1.35 | 5.9 | 4179177 | 2.667 | 7.2 | 4179188 | 6.096 | 10.6 |
| 4179163 | 1.372 | 5.9 | 4179178 | 2.704 | 7.2 | 4179189 | 6.35 | 10.9 |
| 4179164 | 1.385 | 5.9 | 4179179 | 2.713 | 7.2 | 4170567 | 6.5 | 11 |
| 4170552 | 1.5 | 6 | 4179180 | 2.721 | 7.2 | 4170572 | 7 | 11.5 |
| 4179165 | 1.524 | 6 | 4179181 | 2.743 | 7.2 | 4170573 | 8 | 12.5 |
| 4179166 | 1.54 | 6 | 4170565 | 2.75 | 7.3 | 4170574 | 9 | 13.5 |
| 4179167 | 1.6 | 6.1 | 4170557 | 3 | 7.5 | 4170575 | 10 | 14.5 |
| 4179168 | 1.65 | 6.2 | 4179182 | 3.048 | 7.5 | | | |

Micromar

Carbide roller blades

FEATURES

- For gear measurement and for special tasks
- Carbide contact roller
- Cylindrical mounting shank with circlip for mounting in the mounting bore of the micrometer or indicating snap gage

| Order no. | b mm | d mm | h mm |
|-----------|---------|---------|---------|
| 4510200 | 5 | 1 | 5.5 |
| 4510201 | 5 | 1.25 | 5.8 |
| 4510202 | 5 | 1.5 | 6 |
| 4510203 | 5 | 1.75 | 6.3 |
| 4510204 | 5 | 2 | 6.5 |
| 4510206 | 5.5 | 2.5 | 7 |
| 4510207 | 5.5 | 3 | 7.5 |
| 4510208 | 5.5 | 3.5 | 8 |
| 4510209 | 5.5 | 4 | 8.5 |
| 4510210 | 5.5 | 4.5 | 9 |
| 4510211 | 6 | 5 | 9.5 |
| 4510212 | 6 | 5.5 | 10 |
| 4510213 | 6 | 6 | 10.5 |

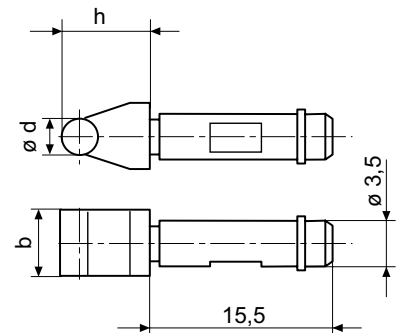

Micromar 40 EWRI-S

Digital micrometer



FUNCTIONS

- RESET (set display to zero)
- ABS (display can be set to zero without losing reference to ORIGIN)
- mm/inch
- ORIGIN (for entering a numerical value)
- LOCK function (key lock)
- TOL (Tolerance and Warning Limits Input)
- HOLD (storage of measured values)
- DATA (data transmission)
- Bidirectional data interface (external output and input option of characteristic values as well as setting of individual lock functions by MarCom Software)

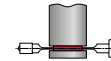
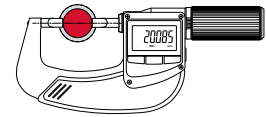

Application:

- For measuring recesses, grooves, etc.

FEATURES

- With blade-type measuring surfaces
- High contrast digital display
- Stainless spindle is hardened throughout and ground
- Quick drive
- Sliding spindle
- Ratchet is integrated in the thimble
- Lacquered steel frame, heat insulated
- **Software:** MarCom Professional free download: www.mahr.com/marcom (only for Mahr data cables and wireless systems with USB and RS-232 interface)
- **Digit height:** 10 mm
- **Data interface:** Integrated Wireless
- **Energy supply:** Battery life approx. 2 years
- **Battery type:** CR 2032 (3V Lithium)
- **IP protection category:** IP 65
- **Package contains:** instruction manual, battery, setting standard (measuring range of 25–50 mm), case

TECHNICAL DATA

| Order no. | Type | Measuring range | Measuring range | Measuring surface | Resolution | Error limit | Spindle thread pitch | Measuring force | Standard | Model contact surface |
|-----------|-----------|-----------------|-----------------|-------------------|-----------------|-------------|----------------------|-----------------|-----------|-----------------------|
| | | mm | inch | | mm/inch | µm | mm | N | | |
| 4157141 | 40 EWRI-S | 0–25 | 0–1" | hardened steel | 0.001 / .00005" | 4 | 5 | 5–10 | DIN 863–3 | Blade |
| 4157142 | 40 EWRI-S | 25–50 | 1–2" | hardened steel | 0.001 / .00005" | 4 | 5 | 5–10 | DIN 863–3 | Blade |
| 4157143 | 40 EWRI-S | 50–75 | 2–3" | hardened steel | 0.001 / .00005" | 5 | 5 | 5–10 | DIN 863–3 | Blade |
| 4157144 | 40 EWRI-S | 75–100 | 3–4" | hardened steel | 0.001 / .00005" | 5 | 5 | 5–10 | DIN 863–3 | Blade |

| Order no. | a | b | c |
|-----------|----|------|-------|
| | mm | mm | mm |
| 4157141 | 32 | 11.5 | 57 |
| 4157142 | 44 | 13.5 | 82 |
| 4157143 | 57 | 15.5 | 107 |
| 4157144 | 73 | 17 | 132.5 |

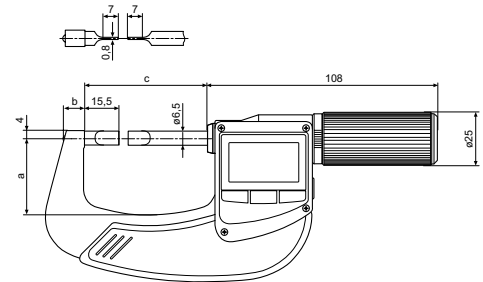

ACCESSORIES

| Order no. | Description | Type |
|-----------|---|---------|
| 4102220 | Receiver for instruments with Integrated Wireless | i-Stick |
| 4158000 | Stand for holding outside micrometers | 41 H |



41 H



i-Stick

Micromar 40 EWR-S

Digital micrometer



FUNCTIONS

- RESET (set display to zero)
- ABS (display can be set to zero without losing reference to ORIGIN)
- mm/inch
- ORIGIN (for entering a numerical value)
- LOCK function (key lock)
- TOL (Tolerance and Warning Limits Input)
- HOLD (storage of measured values)
- DATA (data transmission)
- Bidirectional data interface (external output and input option of characteristic values as well as setting of individual lock functions by MarCom Software)

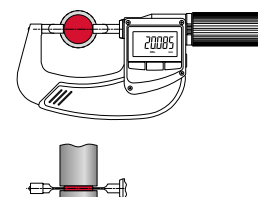

Application:

- For measuring recesses, grooves, etc.

FEATURES

- With blade-type measuring surfaces
- High contrast digital display
- Stainless spindle is hardened throughout and ground
- Quick drive
- Sliding spindle
- Ratchet is integrated in the thimble
- Lacquered steel frame, heat insulated
- **Software:** MarCom Professional free download: www.mahr.com/marcom (only for Mahr data cables and wireless systems with USB and RS-232 interface)
- **Digit height:** 10 mm
- **Data interface:** MarConnect (bidirectional), USB, Digimatic
- **Energy supply:** Battery life approx. 2 years
- **Battery type:** CR 2032 (3V Lithium)
- **IP protection category:** IP 65
- **Package contains:** instruction manual, battery, setting standard (measuring range of 25–50 mm), case

TECHNICAL DATA

| Order no. | Type | Measuring range | | Measuring surface | Resolution | Error limit | Spindle thread pitch | Measuring force | Standard | Model contact surface |
|-----------|----------|-----------------|------|-------------------|-----------------|-------------|----------------------|-----------------|-----------|-----------------------|
| | | mm | inch | | | | | | | |
| 4157041 | 40 EWR-S | 0–25 | 0–1" | hardened steel | 0.001 / .00005" | 4 | 5 | 5–10 | DIN 863–3 | Blade |
| 4157042 | 40 EWR-S | 25–50 | 1–2" | hardened steel | 0.001 / .00005" | 4 | 5 | 5–10 | DIN 863–3 | Blade |
| 4157043 | 40 EWR-S | 50–75 | 2–3" | hardened steel | 0.001 / .00005" | 5 | 5 | 5–10 | DIN 863–3 | Blade |
| 4157044 | 40 EWR-S | 75–100 | 3–4" | hardened steel | 0.001 / .00005" | 5 | 5 | 5–10 | DIN 863–3 | Blade |

| Order no. | a | b | c |
|-----------|----|------|-------|
| | mm | mm | mm |
| 4157041 | 32 | 11.5 | 57 |
| 4157042 | 44 | 13.5 | 82 |
| 4157043 | 57 | 15.5 | 107 |
| 4157044 | 73 | 17 | 132.5 |

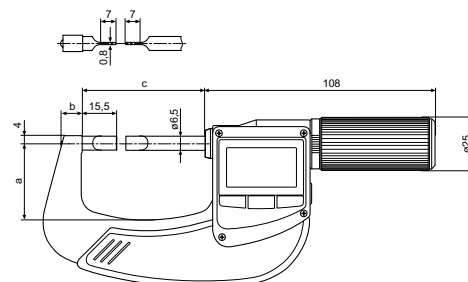

ACCESSORIES

| Order no. | Description | Type |
|-----------|---|-------|
| 4102603 | Data cable USB bidirectional (2 m) | DK-U1 |
| 4102606 | Interface adapter with data cable Digimatic (2 m) | DK-D1 |
| 4158000 | Stand for holding outside micrometers | 41 H |



41 H

Micromar 40 EWRI-B

Digital micrometer



FUNCTIONS

- RESET (set display to zero)
- ABS (display can be set to zero without losing reference to ORIGIN)
- mm/inch
- ORIGIN (for entering a numerical value)
- LOCK function (key lock)
- TOL (Tolerance and Warning Limits Input)
- HOLD (storage of measured values)
- DATA (data transmission)
- Bidirectional data interface (external output and input option of characteristic values as well as setting of individual lock functions by MarCom Software)

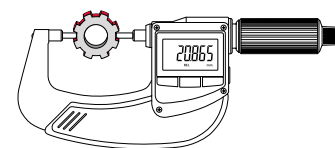

Application:

- For measuring grooves, spline shafts, recesses, etc.

FEATURES

- Reduced measuring surfaces \varnothing 3 mm
- High contrast digital display
- Stainless spindle is hardened throughout and ground
- Spindle and anvil are carbide-tipped
- Rapid drive
- Ratchet is integrated in the thimble
- Lacquered steel frame, heat insulated
- **Software:** MarCom Professional free download: www.mahr.com/marcom (only for Mahr data cables and wireless systems with USB and RS-232 interface)
- **Digit height:** 10 mm
- **Data interface:** Integrated Wireless
- **Energy supply:** Battery life approx. 2 years
- **Battery type:** CR 2032 (3V Lithium)
- **IP protection category:** IP 65
- **Package contains:** instruction manual, battery, setting standard (measuring range of 25–50 mm), case

TECHNICAL DATA

| Order no. | Type | Measuring range | Measuring range | Measuring surface | Resolution | Error limit | Spindle thread pitch | Measuring force | Standard | Model contact surface |
|-----------|-----------|-----------------|-----------------|-------------------|-----------------|-------------|----------------------|-----------------|-----------|-----------------------|
| | | mm | inch | | mm/inch | μ m | mm | N | | |
| 4157132 | 40 EWRI-B | 0–25 | 0–1" | carbide | 0.001 / .00005" | 4 | 0.5 | 5–10 | DIN 863–3 | flat, reduced |
| 4157133 | 40 EWRI-B | 25–50 | 1–2" | carbide | 0.001 / .00005" | 4 | 0.5 | 5–10 | DIN 863–3 | flat, reduced |

| Order no. | a | b | c |
|-----------|----|------|----|
| | mm | mm | mm |
| 4157132 | 32 | 11.5 | 57 |
| 4157133 | 44 | 13.5 | 82 |

40 EWR(i)-B

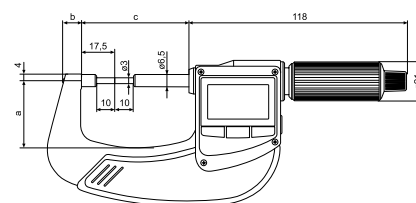

ACCESSORIES

| Order no. | Description | Type |
|-----------|---|---------|
| 4102220 | Receiver for instruments with Integrated Wireless | i-Stick |
| 4158000 | Stand for holding outside micrometers | 41 H |



41 H



i-Stick

Micromar 40 EWR-B

Digital micrometer



FUNCTIONS

- RESET (set display to zero)
- ABS (display can be set to zero without losing reference to ORIGIN)
- mm/inch
- ORIGIN (for entering a numerical value)
- LOCK function (key lock)
- TOL (Tolerance and Warning Limits Input)
- HOLD (storage of measured values)
- DATA (data transmission)
- Bidirectional data interface (external output and input option of characteristic values as well as setting of individual lock functions by MarCom Software)

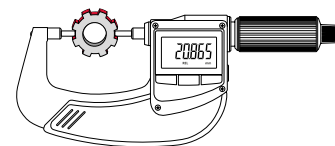

Application:

- For measuring grooves, spline shafts, recesses, etc.

FEATURES

- Reduced measuring surfaces $\varnothing 3$ mm
- High contrast digital display
- Stainless spindle is hardened throughout and ground
- Spindle and anvil are carbide-tipped
- Rapid drive
- Ratchet is integrated in the thimble
- Lacquered steel frame, heat insulated
- **Software:** MarCom Professional free download: www.mahr.com/marcom (only for Mahr data cables and wireless systems with USB and RS-232 interface)
- **Digit height:** 10 mm
- **Data interface:** MarConnect (bidirectional), USB, Digimatic
- **Energy supply:** Battery life approx. 2 years
- **Battery type:** CR 2032 (3V Lithium)
- **IP protection category:** IP 65
- **Package contains:** instruction manual, battery, setting standard (measuring range of 25–50 mm), case

TECHNICAL DATA

| Order no. | Type | Measuring range | Measuring range | Measuring surface | Resolution | Error limit | Spindle thread pitch | Measuring force | Standard | Model contact surface |
|-----------|----------|-----------------|-----------------|-------------------|-----------------|---------------|----------------------|-----------------|-----------|-----------------------|
| | | mm | inch | | mm/inch | μm | mm | N | | |
| 4157032 | 40 EWR-B | 0–25 | 0–1" | carbide | 0.001 / .00005" | 4 | 0.5 | 5–10 | DIN 863–3 | flat, reduced |
| 4157033 | 40 EWR-B | 25–50 | 1–2" | carbide | 0.001 / .00005" | 4 | 0.5 | 5–10 | DIN 863–3 | flat, reduced |

| Order no. | a | b | c |
|-----------|----|------|----|
| | mm | mm | mm |
| 4157032 | 32 | 11.5 | 57 |
| 4157033 | 44 | 13.5 | 82 |

40 EWR(i)-B

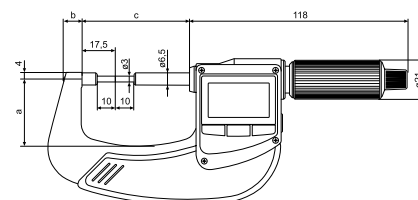

ACCESSORIES

| Order no. | Description | Type |
|-----------|---|-------|
| 4102603 | Data cable USB bidirectional (2 m) | DK-U1 |
| 4102606 | Interface adapter with data cable Digimatic (2 m) | DK-D1 |
| 4158000 | Stand for holding outside micrometers | 41 H |



41 H

Micromar 40 EWRI-R

Digital micrometer



FUNCTIONS

- RESET (set display to zero)
- ABS (display can be set to zero without losing reference to ORIGIN)
- mm/inch
- ORIGIN (for entering a numerical value)
- LOCK function (key lock)
- TOL (Tolerance and Warning Limits Input)
- HOLD (storage of measured values)
- DATA (data transmission)
- Bidirectional data interface (external output and input option of characteristic values as well as setting of individual lock functions by MarCom Software)



Application:

- For measuring the thickness of pipe walls

FEATURES

- Measuring surfaces: spherical anvil, planar spindle
- High contrast digital display
- Stainless spindle is hardened throughout and ground
- Spindle and anvil are carbide-tipped
- Rapid drive
- Ratchet is integrated in the thimble
- Lacquered steel frame, heat insulated
- **Software:** MarCom Professional free download: www.mahr.com/marcom (only for Mahr data cables and wireless systems with USB and RS-232 interface)
- **Digit height:** 10 mm
- **Data interface:** Integrated Wireless
- **Energy supply:** Battery life approx. 2 years
- **Battery type:** CR 2032 (3V Lithium)
- **IP protection category:** IP 65
- **Package contains:** instruction manual, battery, setting standard (measuring range of 25–50 mm), case

TECHNICAL DATA

| Order no. | Type | Measuring range | Measuring range | Measuring surface | Resolution | Error limit | Spindle thread pitch | Measuring force | Standard | Model contact surface |
|-----------|-----------|-----------------|-----------------|-------------------|-----------------|-------------|----------------------|-----------------|-----------|-----------------------|
| | | mm | inch | | mm/inch | µm | mm | N | | |
| 4157130 | 40 EWRI-R | 0–25 | 0–1" | carbide | 0.001 / .00005" | 4 | 0.5 | 5–10 | DIN 863–3 | flat, spherical |
| 4157131 | 40 EWRI-R | 25–50 | 1–2" | carbide | 0.001 / .00005" | 4 | 0.5 | 5–10 | DIN 863–3 | flat, spherical |

| Order no. | a | b | c |
|-----------|----|------|------|
| | mm | mm | mm |
| 4157130 | 23 | 9.5 | 31.5 |
| 4157131 | 32 | 11.5 | 57 |

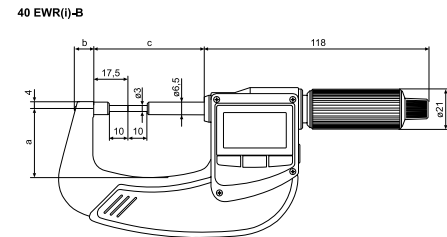

ACCESSORIES

| Order no. | Description | Type |
|-----------|---|---------|
| 4102220 | Receiver for instruments with Integrated Wireless | i-Stick |
| 4158000 | Stand for holding outside micrometers | 41 H |



41 H



i-Stick

Micromar 40 EWR-R

Digital micrometer



FUNCTIONS

- RESET (set display to zero)
- ABS (display can be set to zero without losing reference to ORIGIN)
- mm/inch
- ORIGIN (for entering a numerical value)
- LOCK function (key lock)
- TOL (Tolerance and Warning Limits Input)
- HOLD (storage of measured values)
- DATA (data transmission)
- Bidirectional data interface (external output and input option of characteristic values as well as setting of individual lock functions by MarCom Software)

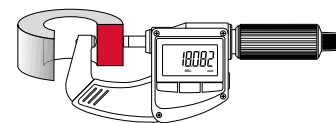

Application:

- For measuring the thickness of pipe walls

FEATURES

- Measuring surfaces: spherical anvil, planar spindle
- High contrast digital display
- Stainless spindle is hardened throughout and ground
- Spindle and anvil are carbide-tipped
- Rapid drive
- Ratchet is integrated in the thimble
- Lacquered steel frame, heat insulated
- **Software:** MarCom Professional free download: www.mahr.com/marcom (only for Mahr data cables and wireless systems with USB and RS-232 interface)
- **Digit height:** 10 mm
- **Data interface:** MarConnect (bidirectional), USB, Digimatic
- **Energy supply:** Battery life approx. 2 years
- **Battery type:** CR 2032 (3V Lithium)
- **IP protection category:** IP 65
- **Package contains:** instruction manual, battery, setting standard (measuring range of 25–50 mm), case

TECHNICAL DATA

| Order no. | Type | Measuring range | Measuring range | Measuring surface | Resolution | Error limit | Spindle thread pitch | Measuring force | Standard | Model contact surface |
|-----------|----------|-----------------|-----------------|-------------------|-----------------|-------------|----------------------|-----------------|-----------|-----------------------|
| 4157030 | 40 EWR-R | 0–25 | 0–1" | carbide | 0.001 / .00005" | 4 | 0.5 | 5–10 | DIN 863–3 | flat, spherical |
| 4157031 | 40 EWR-R | 25–50 | 1–2" | carbide | 0.001 / .00005" | 4 | 0.5 | 5–10 | DIN 863–3 | flat, spherical |

| Order no. | a | b | c |
|-----------|----|------|------|
| | mm | mm | mm |
| 4157030 | 23 | 9.5 | 31.5 |
| 4157031 | 32 | 11.5 | 57 |

40 EWR(i)-B

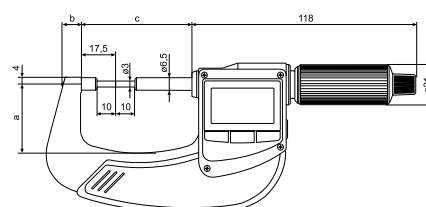

ACCESSORIES

| Order no. | Description | Type |
|-----------|---|-------|
| 4102603 | Data cable USB bidirectional (2 m) | DK-U1 |
| 4102606 | Interface adapter with data cable Digimatic (2 m) | DK-D1 |
| 4158000 | Stand for holding outside micrometers | 41 H |



41 H

Micromar 40 EWRI-K

Digital micrometer



FUNCTIONS

- RESET (set display to zero)
- ABS (display can be set to zero without losing reference to ORIGIN)
- mm/inch
- ORIGIN (for entering a numerical value)
- LOCK function (key lock)
- TOL (Tolerance and Warning Limits Input)
- HOLD (storage of measured values)
- DATA (data transmission)
- Bidirectional data interface (external output and input option of characteristic values as well as setting of individual lock functions by MarCom Software)



Application:

- For measuring crimp heights

FEATURES

- Measuring surfaces: anvil with narrow web, pointed spindle
- High contrast digital display
- Stainless spindle is hardened throughout and ground
- Spindle and anvil are carbide-tipped
- Rapid drive
- Ratchet is integrated in the thimble
- Lacquered steel frame, heat insulated
- **Software:** MarCom Professional free download: www.mahr.com/marcom (only for Mahr data cables and wireless systems with USB and RS-232 interface)
- **Digit height:** 10 mm
- **Data interface:** Integrated Wireless
- **Energy supply:** Battery life approx. 2 years
- **Battery type:** CR 2032 (3V Lithium)
- **IP protection category:** IP 65
- **Package contains:** instruction manual, battery, case

TECHNICAL DATA

| Order no. | Type | Measuring range | Measuring range | Measuring surface | Resolution | Error limit | Spindle thread pitch | Measuring force | Standard | Model contact surface |
|-----------|-----------|-----------------|-----------------|-------------------|----------------------------|-------------|----------------------|-----------------|------------------|-----------------------|
| 4157140 | 40 EWRI-K | 0–20 | 0–0.8" | carbide | mm/inch 0.001 / .00005" | μm 4 | mm 0.5 | N 5–10 | Factory standard | Blade, taper |

| Order no. | a | b | c |
|-----------|----------|-----------|------------|
| 4157140 | mm 23 | mm 9.5 | mm 31.5 |

40 EWR(i)-K

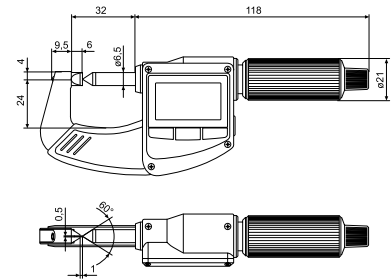

ACCESSORIES

| Order no. | Description | Type |
|-----------|---|---------|
| 4102220 | Receiver for instruments with Integrated Wireless | i-Stick |
| 4158000 | Stand for holding outside micrometers | 41 H |



41 H



i-Stick

Micromar 40 EWR-K

Digital micrometer



FUNCTIONS

- RESET (set display to zero)
- ABS (display can be set to zero without losing reference to ORIGIN)
- mm/inch
- ORIGIN (for entering a numerical value)
- LOCK function (key lock)
- TOL (Tolerance and Warning Limits Input)
- HOLD (storage of measured values)
- DATA (data transmission)
- Bidirectional data interface (external output and input option of characteristic values as well as setting of individual lock functions by MarCom Software)

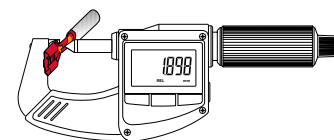

Application:

- For measuring crimp heights on crimp contacts and end splices

FEATURES

- Measuring surfaces: anvil with narrow web, pointed spindle
- High contrast digital display
- Stainless spindle is hardened throughout and ground
- Spindle and anvil are carbide-tipped
- Rapid drive
- Ratchet is integrated in the thimble
- Lacquered steel frame, heat insulated
- **Software:** MarCom Professional free download: www.mahr.com/marcom (only for Mahr data cables and wireless systems with USB and RS-232 interface)
- **Digit height:** 10 mm
- **Data interface:** MarConnect (bidirectional), USB, Digimatic
- **Energy supply:** Battery life approx. 2 years
- **Battery type:** CR 2032 (3V Lithium)
- **IP protection category:** IP 65
- **Package contains:** instruction manual, battery, case

TECHNICAL DATA

| Order no. | Type | Measuring range | Measuring range | Measuring surface | Resolution | Error limit | Spindle thread pitch | Measuring force | Standard | Model contact surface |
|-----------|----------|-----------------|-----------------|-------------------|-----------------|-------------|----------------------|-----------------|------------------|-----------------------|
| | | mm | inch | | mm/inch | μm | mm | N | | |
| 4157040 | 40 EWR-K | 0–20 | 0–0.8" | carbide | 0.001 / .00005" | 4 | 0.5 | 5–10 | Factory standard | Blade, taper |

| Order no. | a | b | c |
|-----------|----|-----|------|
| | mm | mm | mm |
| 4157040 | 23 | 9.5 | 31.5 |

40 EWR(i)-K

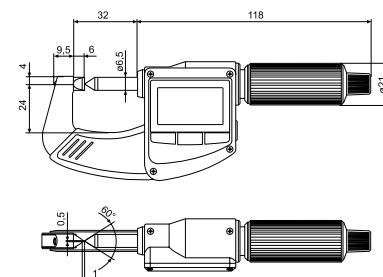

ACCESSORIES

| Order no. | Description | Type |
|-----------|---|-------|
| 4102603 | Data cable USB bidirectional (2 m) | DK-U1 |
| 4102606 | Interface adapter with data cable Digimatic (2 m) | DK-D1 |
| 4158000 | Stand for holding outside micrometers | 41 H |



41 H

FEATURES

- Operating and display units with satin chrome finish
- Rigid, lightweight tubular construction
- Stainless spindle is hardened throughout and ground
- Measuring faces spherically lapped, one measuring face adjustable
- Measuring range of 100–125 mm with heat insulators and a locking device
- Package contains: case



TECHNICAL DATA

| Order no. | Type | Measuring range | Readings | Error limit | Spindle thread pitch | Standard |
|-----------|------|-----------------|----------|-------------|----------------------|-----------|
| | | mm | | μm | mm | |
| 4163000 | 44 F | 30–40 | 0.01 | 4 | 0.5 | DIN 863-4 |
| 4163001 | 44 F | 40–50 | 0.01 | 4 | 0.5 | DIN 863-4 |
| 4163002 | 44 F | 50–70 | 0.01 | 5 | 0.5 | DIN 863-4 |
| 4163003 | 44 F | 70–100 | 0.01 | 5 | 0.5 | DIN 863-4 |
| 4163004 | 44 F | 100–125 | 0.01 | 6 | 0.5 | DIN 863-4 |
| 4163005 | 44 F | 125–150 | 0.01 | 6 | 0.5 | DIN 863-4 |
| 4163006 | 44 F | 150–175 | 0.01 | 7 | 0.5 | DIN 863-4 |
| 4163007 | 44 F | 175–200 | 0.01 | 7 | 0.5 | DIN 863-4 |

| Order no. | a | b | c | d | e |
|-----------|----|------|-----|-----|------|
| | mm | mm | mm | mm | mm |
| 4163000 | 7 | 12.5 | 2 | 4 | 12.6 |
| 4163001 | 7 | 12.5 | 2.5 | 4.5 | 12.6 |
| 4163002 | 7 | 13.5 | 2.5 | 4.5 | 13.6 |
| 4163003 | 7 | 13.5 | 4.5 | 4.5 | 14 |
| 4163004 | 8 | 20 | 4.5 | 4.5 | 20 |
| 4163005 | 8 | 20 | 8 | 8 | 20 |
| 4163006 | 8 | 20 | 8 | 8 | 20 |
| 4163007 | 8 | 20 | 8 | 8 | 20 |

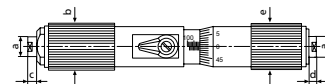

ACCESSORIES

| Order no. | Description | Type |
|-----------|--------------------------------|-------|
| 4710050 | Ring gage DIN 2250 C, Ø 30 mm | 355 E |
| 4710060 | Ring gage DIN 2250 C, Ø 40 mm | 355 E |
| 4710070 | Ring gage DIN 2250 C, Ø 50 mm | 355 E |
| 4710090 | Ring gage DIN 2250 C, Ø 70 mm | 355 E |
| 4710120 | Ring gage DIN 2250 C, Ø 100 mm | 355 E |
| 4710121 | Ring gage DIN 2250 C, Ø 125 mm | 355 E |
| 4710122 | Ring gage DIN 2250 C, Ø 175 mm | 355 E |



355 E

Measuring head

FEATURES

- Operating and display units with satin chrome finish
- Rigid, lightweight tubular construction
- Stainless spindle is hardened throughout and ground
- Locking device
- Carbide tipped spherical measuring faces
- Interchangeable extension 44 Cv contains cylindrical gage rods that are spring mounted in protective sleeves for the extension of the measuring range
- Protection sleeves have a satin chrome finish
- **Package contents:** Measuring head 44 Cm, measuring range of 100–150 mm with extensions 44 Cv, case

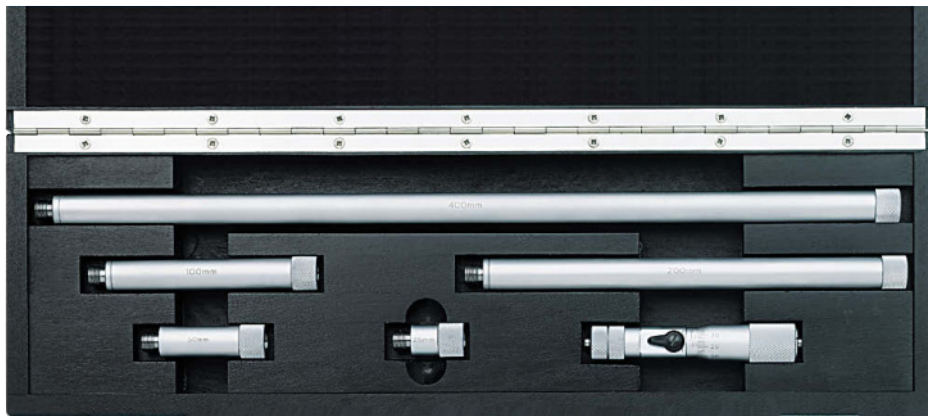

Application:

- For measuring large inside diameters

TECHNICAL DATA

| Order no. | Type | Measuring range | Readings | Extensions 44 Cv | Error limit | Error limit | Spindle thread pitch | Standard |
|-----------|----------|-----------------|----------|---|-------------|--|----------------------|-----------|
| | | mm | | | µm | µm | mm | |
| 4168001 | 44 Cm | 100–125 | 0.01 | | 6 | Manufacturing tolerance of extensions 44 CV: ISO 286 js2 | 0.5 | DIN 863–4 |
| 4168020 | 44 Cms 1 | 100–150 | 0.01 | 25 mm | | | 0.5 | DIN 863–4 |
| 4168021 | 44 Cms 2 | 100–300 | 0.01 | 25 mm | | | 0.5 | DIN 863–4 |
| 4168022 | 44 Cms 3 | 100–500 | 0.01 | 50 / 100 mm 25 / 50 mm 100 / 200 mm | | | 0.5 | DIN 863–4 |
| 4168023 | 44 Cms 4 | 100–900 | 0.01 | 25 / 50 mm 100 / 200 mm 400 mm | | | 0.5 | DIN 863–4 |

| Order no. | a | b | c | d | e |
|-----------|----|----|----|----|----|
| | mm | mm | mm | mm | mm |
| 4168001 | 5 | 16 | 2 | 2 | 18 |
| 4168020 | 5 | 16 | 2 | 2 | 18 |
| 4168021 | 5 | 16 | 2 | 2 | 18 |
| 4168022 | 5 | 16 | 2 | 2 | 18 |
| 4168023 | 5 | 16 | 2 | 2 | 18 |

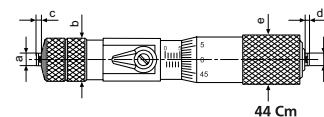

ACCESSORIES

| Order no. | Description | Type |
|-----------|---|-------|
| 4167030 | Individual extension (25 mm) | 44 Cv |
| 4167031 | Individual extension (50 mm) | 44 Cv |
| 4167032 | Individual extension (100 mm) | 44 Cv |
| 4167033 | Individual extension (200 mm) | 44 Cv |
| 4167034 | Individual extension (400 mm) | 44 Cv |
| 4167035 | Individual extension (800 mm) | 44 Cv |
| 4168016 | Wood case for two extensions 44Cv 800mm | |
| 4168160 | Case for 44 Cms | |

FEATURES

- Operating and display units with satin chrome finish
- Stainless spindle is hardened throughout and ground
- Rapid drive with integrated ratchet
- Self-centering measuring head consists of 3 laterally positioned anvils, each are offset at intervals of 120°
- Anvils from 12 mm are carbide tipped
- From 12 mm the anvils can be used to measure the bottom of a bore
- From 40 mm all measuring heads are made from aluminium to reduce weight
- **Package contains:** instruction manual, allen key, key for replacing measuring heads (from 30 mm), case



TECHNICAL DATA

| Order no. | Type | Measuring range mm | Readings mm | Error limit µm | Spindle thread pitch mm | Standard | Measuring depth mm | Measuring depth with extension mm |
|-----------|------|-----------------------|----------------|-------------------|----------------------------|-----------|-----------------------|--------------------------------------|
| 4190310 | 44 A | 6–8 | 0.001 | 4 | 0.5 | DIN 863–4 | 58 | 133 |
| 4190311 | 44 A | 8–10 | 0.001 | 4 | 0.5 | DIN 863–4 | 58 | 133 |
| 4190312 | 44 A | 10–12 | 0.001 | 4 | 0.5 | DIN 863–4 | 58 | 133 |
| 4190313 | 44 A | 12–16 | 0.001 | 4 | 0.5 | DIN 863–4 | 64 | 139 |
| 4190314 | 44 A | 16–20 | 0.001 | 4 | 0.5 | DIN 863–4 | 64 | 139 |
| 4190315 | 44 A | 20–25 | 0.005 | 4 | 0.5 | DIN 863–4 | 68 | 218 |
| 4190316 | 44 A | 25–30 | 0.005 | 4 | 0.5 | DIN 863–4 | 68 | 218 |
| 4190317 | 44 A | 30–40 | 0.005 | 4 | 0.5 | DIN 863–4 | 76 | 226 |
| 4190319 | 44 A | 40–50 | 0.005 | 4 | 0.5 | DIN 863–4 | 76 | 226 |
| 4190320 | 44 A | 50–60 | 0.005 | 5 | 0.5 | DIN 863–4 | 79 | 229 |
| 4190321 | 44 A | 60–70 | 0.005 | 5 | 0.5 | DIN 863–4 | 79 | 229 |
| 4190012 | 44 A | 70–85 | 0.005 | 5 | 0.5 | DIN 863–4 | 97 | 247 |
| 4190013 | 44 A | 85–100 | 0.005 | 5 | 0.5 | DIN 863–4 | 97 | 247 |
| 4190014 | 44 A | 100–125 | 0.005 | 6 | 0.5 | DIN 863–4 | 132 | 282 |
| 4190015 | 44 A | 125–150 | 0.005 | 6 | 0.5 | DIN 863–4 | 132 | 282 |
| 4190016 | 44 A | 150–175 | 0.005 | 7 | 0.5 | DIN 863–4 | 132 | 282 |
| 4190017 | 44 A | 175–200 | 0.005 | 7 | 0.5 | DIN 863–4 | 132 | 282 |

| Order no. | a | b | c | d | Order no. | a | b | c | d |
|-----------|-----|-----|-----|----|-----------|----|----|----|-----|
| | mm | mm | mm | mm | | mm | mm | mm | mm |
| 4190310 | 1.5 | 4 | 1.5 | 58 | 4190320 | | 18 | 5 | 79 |
| 4190311 | 1.8 | 4.3 | 1.5 | 58 | 4190321 | | 18 | 5 | 79 |
| 4190312 | 1.8 | 4.3 | 1.5 | 58 | 4190012 | | 23 | 7 | 97 |
| 4190313 | | 6.5 | 4 | 64 | 4190013 | | 23 | 7 | 97 |
| 4190314 | | 6.5 | 4 | 64 | 4190014 | | 27 | 7 | 132 |
| 4190315 | | 9 | 4 | 68 | 4190015 | | 27 | 7 | 132 |
| 4190316 | | 9 | 4 | 68 | 4190016 | | 27 | 7 | 132 |
| 4190317 | | 15 | 5 | 76 | 4190017 | | 27 | 7 | 132 |
| 4190319 | | 15 | 5 | 76 | | | | | |

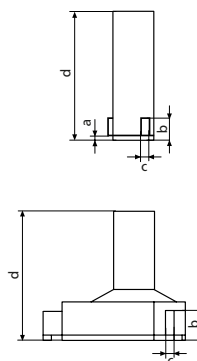

ACCESSORIES

| Order no. | Description | Type |
|-----------|-------------------------------------|-------|
| 4710026 | Ring gage DIN 2250 C, Ø 8 mm | 355 E |
| 4710030 | Ring gage DIN 2250 C, Ø 10 mm | 355 E |
| 4710032 | Ring gage DIN 2250 C, Ø 12 mm | 355 E |
| 4710036 | Ring gage DIN 2250 C, Ø 16 mm | 355 E |
| 4710040 | Ring gage DIN 2250 C, Ø 20 mm | 355 E |
| 4710045 | Ring gage DIN 2250 C, Ø 25 mm | 355 E |
| 4710050 | Ring gage DIN 2250 C, Ø 30 mm | 355 E |
| 4710060 | Ring gage DIN 2250 C, Ø 40 mm | 355 E |
| 4710070 | Ring gage DIN 2250 C, Ø 50 mm | 355 E |
| 4710080 | Ring gage DIN 2250 C, Ø 60 mm | 355 E |
| 4710105 | Ring gage DIN 2250 C, Ø 85 mm | 355 E |
| 4710121 | Ring gage DIN 2250 C, Ø 125 mm | 355 E |
| 4710122 | Ring gage DIN 2250 C, Ø 175 mm | 355 E |
| 4190090 | Depth extension 75 mm, (6–12 mm) | 44 Av |
| 4190091 | Depth extension 75 mm, (12–20 mm) | 44 Av |
| 4190092 | Depth extension 150 mm, (20–30 mm) | 44 Av |
| 4190093 | Depth extension 150 mm, (30–200 mm) | 44 Av |

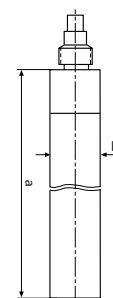

44 Av

FEATURES

- Operating and display units with satin chrome finish
- Stainless spindle is hardened throughout and ground
- Rapid drive with integrated ratchet
- Self-centering measuring head consists of 3 laterally positioned anvils, each are offset at intervals of 120°
- Anvils from 12 mm are carbide tipped
- From 12 mm the anvils can be used to measure the bottom of a bore
- From 40 mm all measuring heads are made from aluminium to reduce weight
- **Package contains:** instruction manual, setting rings, key for replacing measuring heads (from 30 mm), allen key, case

Applications:

For measuring

- Through holes
- Blind holes
- Centering shoulders



TECHNICAL DATA

| Order no. | Type | Measuring range | Readings | Error limit | Standard | Number of micrometers | Setting rings |
|-----------|-------|-----------------|----------|-------------|-----------|-----------------------|---------------|
| | | mm | | µm | | | |
| 4190350 | 44 AS | 6 – 12 | 0.001 | 4 | DIN 863-4 | 3 | 8 mm, 10 mm |
| 4190351 | 44 AS | 12 – 20 | 0.001 | 4 | DIN 863-4 | 2 | 16 mm |
| 4190352 | 44 AS | 20 – 50 | 0.005 | 4 | DIN 863-4 | 4 | 25 mm, 40 mm |
| 4190353 | 44 AS | 50 – 100 | 0.005 | 5 | DIN 863-4 | 4 | 60 mm, 85 mm |

ACCESSORIES

| Order no. | Description | Type |
|-----------|---------------------------------------|-------|
| 4190090 | Depth extension 75 mm, (6 – 12 mm) | 44 Av |
| 4190091 | Depth extension 75 mm, (12 – 20 mm) | 44 Av |
| 4190092 | Depth extension 150 mm, (20 – 30 mm) | 44 Av |
| 4190093 | Depth extension 150 mm, (30 – 200 mm) | 44 Av |

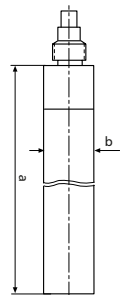

44 Av

Micromar 44 EWR

Digital inside micrometer



FUNCTIONS

- RESET (set display to zero)
- ABS (display can be set to zero without losing reference to preset)
- mm/inch
- PRESET (for entering a numerical value)
- DATA (data transmission via connection cable)
- LOCK function (key lock)

FEATURES

- Threaded connection for changing the measuring head
- Self-centering measuring head consists of 3 laterally positioned anvils, each are offset at intervals of 120°
- Anvils from 12 mm are carbide tipped
- From 12 mm the anvils can be used to measure the bottom of a bore
- From 40 mm all measuring heads are made from aluminium to reduce weight
- **Software:** MarCom Professional free download: www.mahr.com/marcom (only for Mahr data cables and wireless systems with USB and RS-232 interface)
- **Digit height:** 8,5 mm
- **Data interface:** Digimatic, Opto RS-232C, USB
- **Energy supply:** Battery life approx. 2 years
- **Battery type:** CR 2032 (3V Lithium)
- **IP protection category:** IP 52
- **Package contains:** basic units 44 EWg, measuring head 44 Ak, instruction manual, battery, case



Applications:
For measuring

- Through holes
- Blind holes
- Centering shoulders

TECHNICAL DATA

| Order no. | Type | Measuring range | | Resolution | Error limit | Standard | Measuring depth | |
|-----------|--------|-----------------|---------------|-----------------|-------------|-----------|-----------------|-------------------|
| | | mm | inch | | | | mm | mm with extension |
| 4191120 | 44 EWR | 6 – 8 | .25 – .3125" | 0.001 / .00005" | 4 | DIN 863-4 | 58 | 133 |
| 4191121 | 44 EWR | 8 – 10 | .3125 – .4" | 0.001 / .00005" | 4 | DIN 863-4 | 58 | 133 |
| 4191122 | 44 EWR | 10 – 12 | .4 – .4725" | 0.001 / .00005" | 4 | DIN 863-4 | 58 | 133 |
| 4191123 | 44 EWR | 12 – 16 | .4725 – .625" | 0.001 / .00005" | 4 | DIN 863-4 | 64 | 139 |
| 4191124 | 44 EWR | 16 – 20 | .625 – .775" | 0.001 / .00005" | 4 | DIN 863-4 | 64 | 139 |
| 4191125 | 44 EWR | 20 – 25 | .775 – 1" | 0.001 / .00005" | 4 | DIN 863-4 | 68 | 218 |
| 4191126 | 44 EWR | 25 – 30 | 1 – 1.2" | 0.001 / .00005" | 4 | DIN 863-4 | 68 | 218 |
| 4191127 | 44 EWR | 30 – 40 | 1.2 – 1.6" | 0.001 / .00005" | 4 | DIN 863-4 | 76 | 226 |
| 4191129 | 44 EWR | 40 – 50 | 1.6 – 2" | 0.001 / .00005" | 4 | DIN 863-4 | 76 | 226 |
| 4191130 | 44 EWR | 50 – 60 | 2 – 2.35" | 0.001 / .00005" | 5 | DIN 863-4 | 79 | 229 |
| 4191131 | 44 EWR | 60 – 70 | 2.35 – 2.75" | 0.001 / .00005" | 5 | DIN 863-4 | 79 | 229 |
| 4191032 | 44 EWR | 70 – 85 | 2.75 – 3.35" | 0.001 / .00005" | 5 | DIN 863-4 | 97 | 247 |
| 4191033 | 44 EWR | 85 – 100 | 3.35 – 4" | 0.001 / .00005" | 5 | DIN 863-4 | 97 | 247 |
| 4191034 | 44 EWR | 100 – 125 | 4 – 4.9" | 0.001 / .00005" | 6 | DIN 863-4 | 132 | 282 |
| 4191035 | 44 EWR | 125 – 150 | 4.9 – 5.9" | 0.001 / .00005" | 6 | DIN 863-4 | 132 | 282 |
| 4191036 | 44 EWR | 150 – 175 | 5.9 – 6.9" | 0.001 / .00005" | 7 | DIN 863-4 | 132 | 282 |
| 4191037 | 44 EWR | 175 – 200 | 6.9 – 7.9" | 0.001 / .00005" | 7 | DIN 863-4 | 132 | 282 |

Micromar 44 EWR

Digital inside micrometer

| Order no. | a | b | c | d |
|-----------|-----|-----|-----|-----|
| | mm | mm | mm | mm |
| 4191120 | 1.5 | 4 | 1.5 | 58 |
| 4191121 | 1.8 | 4.3 | 1.5 | 58 |
| 4191122 | 1.8 | 4.3 | 1.5 | 58 |
| 4191123 | | 6.5 | 4 | 64 |
| 4191124 | | 6.5 | 4 | 64 |
| 4191125 | | 9 | 4 | 68 |
| 4191126 | | 9 | 4 | 68 |
| 4191127 | | 15 | 5 | 76 |
| 4191129 | | 15 | 5 | 76 |
| 4191130 | | 18 | 5 | 79 |
| 4191131 | | 18 | 5 | 79 |
| 4191032 | | 23 | 7 | 97 |
| 4191033 | | 23 | 7 | 97 |
| 4191034 | | 27 | 7 | 132 |
| 4191035 | | 27 | 7 | 132 |
| 4191036 | | 27 | 7 | 132 |
| 4191037 | | 27 | 7 | 132 |

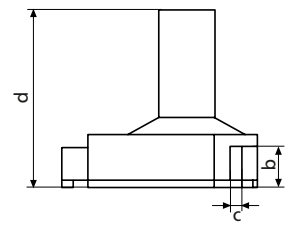
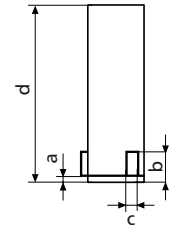

ACCESSORIES

| Order no. | Description | Type |
|-----------|---|---------|
| 4102915 | Interface adapter with data cable Digimatic (2 m) | 16 EWd |
| 4102231 | 16 EWe transmitter for e-Stick | 16 EWe |
| 4102410 | Data connection cable RS232C (2 m) | 16 EXr |
| 4102357 | 16 EXu data connection cable USB (2 m) | 16 EXu |
| 4710026 | Ring gage DIN 2250 C, Ø 8 mm | 355 E |
| 4710030 | Ring gage DIN 2250 C, Ø 10 mm | 355 E |
| 4710032 | Ring gage DIN 2250 C, Ø 12 mm | 355 E |
| 4710036 | Ring gage DIN 2250 C, Ø 16 mm | 355 E |
| 4710040 | Ring gage DIN 2250 C, Ø 20 mm | 355 E |
| 4710045 | Ring gage DIN 2250 C, Ø 25 mm | 355 E |
| 4710050 | Ring gage DIN 2250 C, Ø 30 mm | 355 E |
| 4710060 | Ring gage DIN 2250 C, Ø 40 mm | 355 E |
| 4710070 | Ring gage DIN 2250 C, Ø 50 mm | 355 E |
| 4710080 | Ring gage DIN 2250 C, Ø 60 mm | 355 E |
| 4710105 | Ring gage DIN 2250 C, Ø 85 mm | 355 E |
| 4710121 | Ring gage DIN 2250 C, Ø 125 mm | 355 E |
| 4710122 | Ring gage DIN 2250 C, Ø 175 mm | 355 E |
| 4190090 | Depth extension 75 mm, (6 –12 mm) | 44 Av |
| 4190091 | Depth extension 75 mm, (12 –20 mm) | 44 Av |
| 4190092 | Depth extension 150 mm, (20 –30 mm) | 44 Av |
| 4190093 | Depth extension 150 mm, (30 –200 mm) | 44 Av |
| 4102230 | e-Stick receiver | e-Stick |



16 EWe



e-Stick

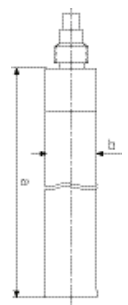

44 Av

Micromar 44 EWR

Digital inside micrometer in set



FUNCTIONS

- RESET (set display to zero)
- ABS (display can be set to zero without losing reference to preset)
- PRESET (for entering a numerical value)
- mm/inch
- LOCK function (key lock)
- DATA (data transmission via connection cable)

FEATURES

- Threaded connection for changing the measuring head
- Self-centering measuring head consists of 3 laterally positioned anvils, each are offset at intervals of 120°
- Anvils from 12 mm are carbide tipped
- From 12 mm the anvils can be used to measure the bottom of a bore
- From 40 mm all measuring heads are made from aluminium to reduce weight
- **Software:** MarCom Professional free download: www.mahr.com/marcom (only for Mahr data cables and wireless systems with USB and RS-232 interface)
- **Digit height:** 8,5 mm
- **Data interface:** Digimatic, Opto RS-232C, USB
- **Energy supply:** Battery life approx. 2 years
- **Battery type:** CR 2032 (3V Lithium)
- **IP protection category:** IP 52
- **Package contains:** basic units 44 EWg, measuring heads 44 Ak, setting rings, battery, instruction manual, case

Applications:

- Through holes
- Blind holes
- Centering shoulders



TECHNICAL DATA

| Order no. | Type | Measuring range | | Resolution | Error limit | Standard | Number of measuring heads 44 Ak | Setting rings |
|-----------|--------|-----------------|---------------|-----------------|-------------|-----------|---------------------------------|---------------|
| | | mm | inch | | | | | |
| 4191160 | 44 EWR | 6 – 12 | .25 – .4725" | 0.001 / .00005" | 4 | DIN 863–4 | 3 | 8 mm, 10 mm |
| 4191161 | 44 EWR | 12 – 20 | .4725 – .775" | 0.001 / .00005" | 4 | DIN 863–4 | 2 | 16 mm |
| 4191162 | 44 EWR | 20 – 50 | .775 – 2" | 0.001 / .00005" | 4 | DIN 863–4 | 4 | 25 mm, 40 mm |
| 4191163 | 44 EWR | 50 – 100 | 2 – 4" | 0.001 / .00005" | 5 | DIN 863–4 | 4 | 60 mm, 85 mm |

ACCESSORIES

| Order no. | Description | Type |
|-----------|---|---------|
| 4102915 | Interface adapter with data cable Digimatic (2 m) | 16 EWd |
| 4102357 | 16 EXu data connection cable USB (2 m) | 16 EXu |
| 4102410 | Data connection cable RS232C (2 m) | 16 EXr |
| 4102231 | 16 EWe transmitter for e-Stick | 16 EWe |
| 4102230 | e-Stick receiver | e-Stick |
| 4190090 | Depth extension 75 mm, (6 – 12 mm) | 44 Av |
| 4190091 | Depth extension 75 mm, (12 – 20 mm) | 44 Av |
| 4190092 | Depth extension 150 mm, (20 – 30 mm) | 44 Av |
| 4190093 | Depth extension 150 mm, (30 – 200 mm) | 44 Av |



16 EWe



e-Stick

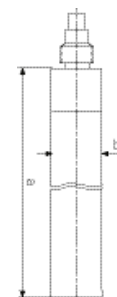

44 Av

Micromar 844 A

Measuring pistol

FEATURES

- Threaded connection for changing the measuring head
- Self-centering measuring head consists of 3 laterally positioned anvils, each are offset at intervals of 120°
- Anvils from 12 mm are carbide tipped
- From 12 mm the anvils can be used to measure the bottom of a bore
- From 40 mm all measuring heads are made from aluminium to reduce weight
- Measuring value indication is always easy to read when using an electronic dial indicator with a rotatable display
- **Package contains:** excludes indicator, basic units 844 Ag, measuring head 44 Ak, instruction manual, case



Applications:

For measuring

- Through holes
- Blind holes
- Centering shoulders

TECHNICAL DATA

| Order no. | Type | Measuring range | | Error limit | Standard | Measuring depth | |
|-----------|-------|-----------------|-------------|-------------|------------------|-----------------|-------------------|
| | | mm | inch | | | mm | mm with extension |
| 4487700 | 844 A | 6-8 | .25-.3125" | 3 | Factory standard | 58 | 133 |
| 4487701 | 844 A | 8-10 | .3125-.4" | 3 | Factory standard | 58 | 133 |
| 4487702 | 844 A | 10-12 | .4-.4725" | 3 | Factory standard | 58 | 133 |
| 4487703 | 844 A | 12-16 | .4725-.625" | 3 | Factory standard | 64 | 139 |
| 4487704 | 844 A | 16-20 | .625-.775" | 3 | Factory standard | 64 | 139 |
| 4487705 | 844 A | 20-25 | .775-1" | 3 | Factory standard | 68 | 218 |
| 4487706 | 844 A | 25-30 | 1-1.2" | 3 | Factory standard | 68 | 218 |
| 4487707 | 844 A | 30-40 | 1.2-1.6" | 3 | Factory standard | 76 | 226 |
| 4487709 | 844 A | 40-50 | 1.6-2" | 3 | Factory standard | 76 | 226 |
| 4487710 | 844 A | 50-60 | 2-2.35" | 4 | Factory standard | 79 | 229 |
| 4487711 | 844 A | 60-70 | 2.35-2.75" | 4 | Factory standard | 79 | 229 |
| 4487612 | 844 A | 70-85 | 2.75-3.35" | 4 | Factory standard | 97 | 247 |
| 4487613 | 844 A | 85-100 | 3.35-4" | 4 | Factory standard | 97 | 247 |
| 4487614 | 844 A | 100-125 | 4-4.9" | 5 | Factory standard | 132 | 282 |
| 4487615 | 844 A | 125-150 | 4.9-5.9" | 5 | Factory standard | 132 | 282 |
| 4487616 | 844 A | 150-175 | 5.9-6.9" | 6 | Factory standard | 132 | 282 |
| 4487617 | 844 A | 175-200 | 6.9-7.9" | 6 | Factory standard | 132 | 282 |

Micromar 844 A

Measuring pistol

| Order no. | a | b | c | d |
|-----------|-----|-----|-----|-----|
| | mm | mm | mm | mm |
| 4487700 | 1.5 | 4 | 1.5 | 58 |
| 4487701 | 1.8 | 4.3 | 1.5 | 58 |
| 4487702 | 1.8 | 4.3 | 1.5 | 58 |
| 4487703 | | 6.5 | 4 | 64 |
| 4487704 | | 6.5 | 4 | 64 |
| 4487705 | | 9 | 4 | 68 |
| 4487706 | | 9 | 4 | 68 |
| 4487707 | | 15 | 5 | 76 |
| 4487709 | | 15 | 5 | 76 |
| 4487710 | | 18 | 5 | 79 |
| 4487711 | | 18 | 5 | 79 |
| 4487612 | | 23 | 7 | 97 |
| 4487613 | | 23 | 7 | 97 |
| 4487614 | | 27 | 7 | 132 |
| 4487615 | | 27 | 7 | 132 |
| 4487616 | | 27 | 7 | 132 |
| 4487617 | | 27 | 7 | 132 |

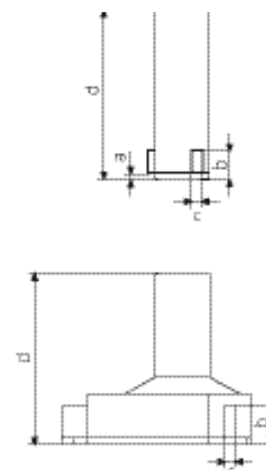

ACCESSORIES

| Order no. | Connection thread | Description | Type |
|-----------|-------------------|---|---------|
| 4337621 | | Digital indicator, 0.0005 mm, 25 mm | 1086 R |
| 4337625 | | Digital indicator, 0.0005 mm, 25 mm | 1086 Ri |
| 4102915 | | Interface adapter with data cable Digimatic (2 m) | 16 EWd |
| 4102410 | | Data connection cable RS232C (2 m) | 16 EXr |
| 4102357 | | 16 EXu data connection cable USB (2 m) | 16 EXu |
| 4710026 | | Ring gage DIN 2250 C, Ø 8 mm | 355 E |
| 4710030 | | Ring gage DIN 2250 C, Ø 10 mm | 355 E |
| 4710036 | | Ring gage DIN 2250 C, Ø 16 mm | 355 E |
| 4710040 | | Ring gage DIN 2250 C, Ø 20 mm | 355 E |
| 4710050 | | Ring gage DIN 2250 C, Ø 30 mm | 355 E |
| 4710060 | | Ring gage DIN 2250 C, Ø 40 mm | 355 E |
| 4710080 | | Ring gage DIN 2250 C, Ø 60 mm | 355 E |
| 4710105 | | Ring gage DIN 2250 C, Ø 85 mm | 355 E |
| 4710121 | | Ring gage DIN 2250 C, Ø 125 mm | 355 E |
| 4710122 | | Ring gage DIN 2250 C, Ø 175 mm | 355 E |
| 4190090 | M5x0.5 | Depth extension 75 mm, (6 – 12 mm) | 44 Av |
| 4190091 | M5x0.5 | Depth extension 75 mm, (12 – 20 mm) | 44 Av |
| 4190092 | M12x1 | Depth extension 150 mm, (20 – 30 mm) | 44 Av |
| 4190093 | M12x1 | Depth extension 150 mm, (30 – 200 mm) | 44 Av |
| 4102220 | | Receiver for instruments with Integrated Wireless | i-Stick |

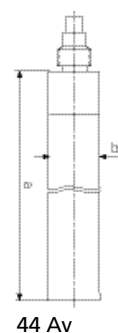

Micromar 844 AS

Measuring pistol in set

FEATURES

- Threaded connection for changing the measuring head
- Self-centering measuring head consists of 3 laterally positioned anvils, each are offset at intervals of 120°
- Anvils from 12 mm are carbide tipped
- From 12 mm the anvils can be used to measure the bottom of a bore
- From 40 mm all measuring heads are made from aluminium to reduce weight
- Measuring value indication is always easy to read when using an electronic dial indicator with a rotatable display
- **Package contains:** instruction manual, setting rings, key for replacing measuring heads (from 30 mm), case

Application:
For measuring

- Through holes
- Blind holes
- Centering shoulders



TECHNICAL DATA

| Order no. | Type | Measuring range | Measuring range | Resolution | Error limit | Standard | Number of measuring heads 44 Ak | Indicating instrument (included in package) | Setting rings |
|-----------|--------|-----------------|-----------------|------------------|-------------|------------------|---------------------------------|---|---------------|
| | | mm | inch | mm/inch | µm | | | | |
| 4487750 | 844 AS | 6 – 12 | .25 – .4725" | | 4 | Factory standard | 3 | Without | 8 mm, 10 mm |
| 4487751 | 844 AS | 12 – 20 | .4725 – .775" | | 4 | Factory standard | 2 | Without | 16 mm |
| 4487752 | 844 AS | 20 – 50 | .775 – 2" | | 4 | Factory standard | 4 | Without | 25 mm, 40 mm |
| 4487753 | 844 AS | 50 – 100 | 2 – 4" | | 5 | Factory standard | 4 | Without | 60 mm, 85 mm |
| 4487760 | 844 AS | 6 – 12 | .25 – .4725" | 0.0005 / .00002" | 4 | Factory standard | 3 | MarCator 1086 R | 8 mm, 10 mm |
| 4487761 | 844 AS | 12 – 20 | .4725 – .775" | 0.0005 / .00002" | 4 | Factory standard | 2 | MarCator 1086 R | 16 mm |
| 4487762 | 844 AS | 20 – 50 | .775 – 2" | 0.0005 / .00002" | 4 | Factory standard | 4 | MarCator 1086 R | 25 mm, 40 mm |
| 4487763 | 844 AS | 50 – 100 | 2 – 4" | 0.0005 / .00002" | 5 | Factory standard | 4 | MarCator 1086 R | 60 mm, 85 mm |

ACCESSORIES

| Order no. | Description | Type |
|-----------|---|---------|
| 4102357 | 16 EXu data connection cable USB (2 m) | 16 EXu |
| 4102410 | Data connection cable RS232C (2 m) | 16 EXr |
| 4102915 | Interface adapter with data cable Digimatic (2 m) | 16 EWd |
| 4102231 | 16 EWe transmitter for e-Stick | 16 EWe |
| 4102230 | e-Stick receiver | e-Stick |
| 4190090 | Depth extension 75 mm, (6 – 12 mm) | 44 Av |
| 4190091 | Depth extension 75 mm, (12 – 20 mm) | 44 Av |
| 4190092 | Depth extension 150 mm, (20 – 30 mm) | 44 Av |
| 4190093 | Depth extension 150 mm, (30 – 200 mm) | 44 Av |



16 EWe



e-Stick



44 Av

Micromar 44 EWg

Basic unit



FUNCTIONS

- RESET (set display to zero)
- ABS (display can be set to zero without losing reference to preset)
- PRESET (for entering a numerical value)
- mm/inch
- LOCK function (key lock)
- DATA (data transmission via connection cable)



FEATURES

- Threaded connection for changing the measuring head
- **Software:** MarCom Professional free download: www.mahr.com/marcom (only for Mahr data cables and wireless systems with USB and RS-232 interface)
- **Data interface:** Digimatic, Opto RS-232C, USB
- **Energy supply:** Battery life approx. 2 years
- **Battery type:** CR 2032 (3V Lithium)
- **IP protection category:** IP 52
- **Package contains:** instruction manual, battery, case

TECHNICAL DATA

| Order no. | Type | Measuring range | | Resolution |
|-----------|--------|-----------------|------------|-----------------|
| | | mm | inch | |
| 4190106 | 44 EWg | 6 –20 | .25 –.775" | 0.001 / .00005" |
| 4190107 | 44 EWg | 20 –100 | .775 –4.0" | 0.001 / .00005" |
| 4190108 | 44 EWg | 100 –200 | 4.0 –7.9" | 0.001 / .00005" |

ACCESSORIES

| Order no. | Description | Type |
|-----------|---|--------|
| 4102520 | Battery 3 V, CR 2032 | |
| 4102357 | 16 EXu data connection cable USB (2 m) | 16 EXu |
| 4102915 | Interface adapter with data cable Digimatic (2 m) | 16 EWd |
| 4102410 | Data connection cable RS232C (2 m) | 16 EXr |
| 4190330 | Measuring head, 6 –8 mm | 44 Ak |
| 4190331 | Measuring head, 8 –10 mm | 44 Ak |
| 4190332 | Measuring head, 10 –12 mm | 44 Ak |
| 4190333 | Measuring head, 12 –16 mm | 44 Ak |
| 4190334 | Measuring head, 16 –20 mm | 44 Ak |
| 4190335 | Measuring head, 20 –25 mm | 44 Ak |
| 4190336 | Measuring head, 25 –30 mm | 44 Ak |
| 4190337 | Measuring head, 30 –40 mm | 44 Ak |
| 4190339 | Measuring head, 40 –50 mm | 44 Ak |
| 4190340 | Measuring head, 50 –60 mm | 44 Ak |
| 4190341 | Measuring head, 60 –70 mm | 44 Ak |
| 4190042 | Measuring head, 70 –85 mm | 44 Ak |
| 4190043 | Measuring head, 85 –100 mm | 44 Ak |
| 4190044 | Measuring head, 100 –125 mm | 44 Ak |
| 4190045 | Measuring head, 125 –150 mm | 44 Ak |
| 4190046 | Measuring head, 150 –175 mm | 44 Ak |
| 4190047 | Measuring head, 175 –200 mm | 44 Ak |

Micromar 844 Ag

Basic instrument measuring pistol

FEATURES

- Threaded connection for changing the measuring head
- Any indicating instrument with an 8 mm mounting shank can be used
- **Package contents:** Model 6–100 mm: includes adapter for 6–20 mm, instruction manual, case



TECHNICAL DATA

| Order no. | Type | Measuring range | |
|-----------|--------|-----------------|------------|
| | | mm | inch |
| 4487635 | 844 Ag | 6 –100 | .25 –4.0" |
| 4487633 | 844 Ag | 20 –100 | .775 –4.0" |
| 4487634 | 844 Ag | 100 –200 | 4.0 –7.9" |

ACCESSORIES

| Order no. | Description | Type |
|-----------|---|---------|
| 4190330 | Measuring head, 6 –8 mm | 44 Ak |
| 4190331 | Measuring head, 8 –10 mm | 44 Ak |
| 4190332 | Measuring head, 10 –12 mm | 44 Ak |
| 4190333 | Measuring head, 12 –16 mm | 44 Ak |
| 4190334 | Measuring head, 16 –20 mm | 44 Ak |
| 4190335 | Measuring head, 20 –25 mm | 44 Ak |
| 4190336 | Measuring head, 25 –30 mm | 44 Ak |
| 4190337 | Measuring head, 30 –40 mm | 44 Ak |
| 4190339 | Measuring head, 40 –50 mm | 44 Ak |
| 4190340 | Measuring head, 50 –60 mm | 44 Ak |
| 4190341 | Measuring head, 60 –70 mm | 44 Ak |
| 4190042 | Measuring head, 70 –85 mm | 44 Ak |
| 4190043 | Measuring head, 85 –100 mm | 44 Ak |
| 4190044 | Measuring head, 100 –125 mm | 44 Ak |
| 4190045 | Measuring head, 125 –150 mm | 44 Ak |
| 4190046 | Measuring head, 150 –175 mm | 44 Ak |
| 4190047 | Measuring head, 175 –200 mm | 44 Ak |
| 4487410 | Adapter for 844 Ag for use with measuring heads 44 Ak 6–20 mm | 844 Aga |

Micromar 44 Ak

Measuring head

FEATURES

- Self-centering measuring head consists of 3 laterally positioned anvils, each are offset at intervals of 120°
- Anvils from 12 mm are carbide tipped
- From 12 mm the anvils can be used to measure the bottom of a bore
- From 40 mm all measuring heads are made from aluminium to reduce weight

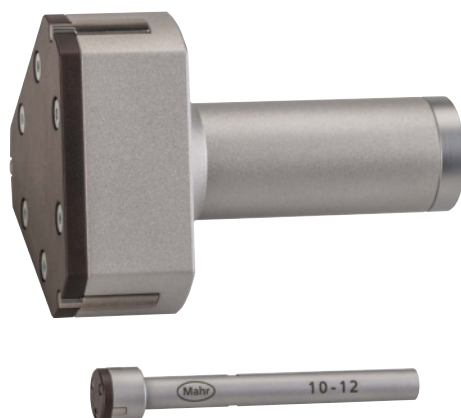

TECHNICAL DATA

| Order no. | Type | Measuring range | |
|-----------|-------|-----------------|---------------|
| | | mm | inch |
| 4190330 | 44 Ak | 6 – 8 | .25 – .3125" |
| 4190331 | 44 Ak | 8 – 10 | .3125 – .4" |
| 4190332 | 44 Ak | 10 – 12 | .4 – .4725" |
| 4190333 | 44 Ak | 12 – 16 | .4725 – .625" |
| 4190334 | 44 Ak | 16 – 20 | .625 – .775" |
| 4190335 | 44 Ak | 20 – 25 | .775 – 1" |
| 4190336 | 44 Ak | 25 – 30 | 1 – 1.2" |
| 4190337 | 44 Ak | 30 – 40 | 1.2 – 1.6" |
| 4190339 | 44 Ak | 40 – 50 | 1.6 – 2" |
| 4190340 | 44 Ak | 50 – 60 | 2 – 2.35" |
| 4190341 | 44 Ak | 60 – 70 | 2.35 – 2.75" |
| 4190042 | 44 Ak | 70 – 85 | 2.75 – 3.35" |
| 4190043 | 44 Ak | 85 – 100 | 3.35 – 4" |
| 4190044 | 44 Ak | 100 – 125 | 4 – 4.9" |
| 4190045 | 44 Ak | 125 – 150 | 4.9 – 5.9" |
| 4190046 | 44 Ak | 150 – 175 | 5.9 – 6.9" |
| 4190047 | 44 Ak | 175 – 200 | 6.9 – 7.9" |

| Order no. | a | b | c | d |
|-----------|-----|-----|-----|-----|
| | mm | mm | mm | mm |
| 4190330 | 1.5 | 4 | 1.5 | 58 |
| 4190331 | 1.8 | 4.3 | 1.5 | 58 |
| 4190332 | 1.8 | 4.3 | 1.5 | 58 |
| 4190333 | | 6.5 | 4 | 64 |
| 4190334 | | 6.5 | 4 | 64 |
| 4190335 | | 9 | 4 | 68 |
| 4190336 | | 9 | 4 | 68 |
| 4190337 | | 15 | 5 | 76 |
| 4190339 | | 15 | 5 | 76 |
| 4190340 | | 18 | 5 | 79 |
| 4190341 | | 18 | 5 | 79 |
| 4190042 | | 23 | 7 | 97 |
| 4190043 | | 23 | 7 | 97 |
| 4190044 | | 27 | 7 | 132 |
| 4190045 | | 27 | 7 | 132 |
| 4190046 | | 27 | 7 | 132 |
| 4190047 | | 27 | 7 | 132 |

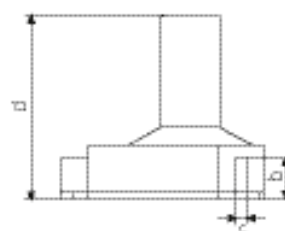
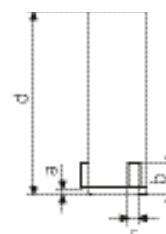

Micromar 45 T

Depth micrometer

FEATURES

- Operating and display units with satin chrome finish
- Stainless spindle is hardened throughout and ground
- Rapid drive with integrated ratchet
- **Package contains:** extensions 25 mm and 50 mm, case



TECHNICAL DATA

| Order no. | Type | Measuring range | Readings | Error limit | Spindle thread pitch | Standard |
|-----------|------|-----------------|------------|--------------------|----------------------|------------------|
| 4180000 | 45 T | mm 0 – 100 | mm 0.01 | μm 5 | mm 0.5 | Factory standard |

| Order no. | a | b | c |
|-----------|-----------|----------|----------|
| 4180000 | mm 100 | mm 16 | mm 13 |

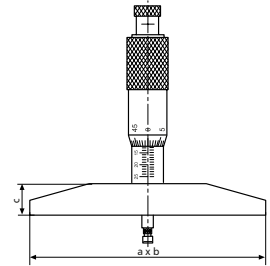

ACCESSORIES

| Order no. | Description | Type |
|-----------|-----------------------|-------|
| 4180001 | Extension (25 mm) | 45 Tv |
| 4180002 | Extension (50 mm) | 45 Tv |
| 4180003 | Extension (100 mm) | 45 T |
| 4180011 | Disc anvil (9 x 1 mm) | 45 Tm |

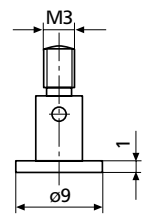

45 Tm

MarTest | Dial test indicators and touch probes

Mahr dial test indicators are ideal for delicate measuring tasks. Their sensitive measuring mechanism ensures maximum security and precision. The display has a hardened mineral glass panel and seal to protect it in harsh workshop conditions.



| | |
|--|------------|
| Overview of dial test indicators | 104 |
| Dial test indicators with scale display | |
| MarTest 800 S / 800 SG / 800 SR / 800 SA / 800 SGA Standard model | 106 |
| MarTest 800 SGB / 800 SL / 800 SGL Dial test indicator measuring device | 107 |
| MarTest 800 SM / 800 SGM / 800 SRM / 800 SGE With long measuring anvil | 108 |
| MarTest 801 SM / 801 SGM / 801 SRM / 801 SGE With long measuring anvil | 110 |
| MarTest 801 S / 801 S1 / 801 SG / 801 SR / 801 SGI With long measuring anvil | 111 |
| MarTest 801 SL / 801 SGL With long measuring anvil | 112 |
| MarTest 800 V / 800 VGM Vertical model | 114 |
| MarTest 801 VGM / 800 V Vertical model | 116 |
| MarTest 800 H Horizontal model | 118 |
| Digital dial test indicators | |
| MarTest 800 EW / 800 EWL Digital dial test indicators | 119 |
| Accessories: holder, measuring and centering arm, measuring stand | 120 |
| 3D touch probes | |
| MarTest 802 EW Digital 3D touch probes | 126 |
| MarTest 802 NW Mechanical 3D touch probe | 127 |

MarTest | Terms

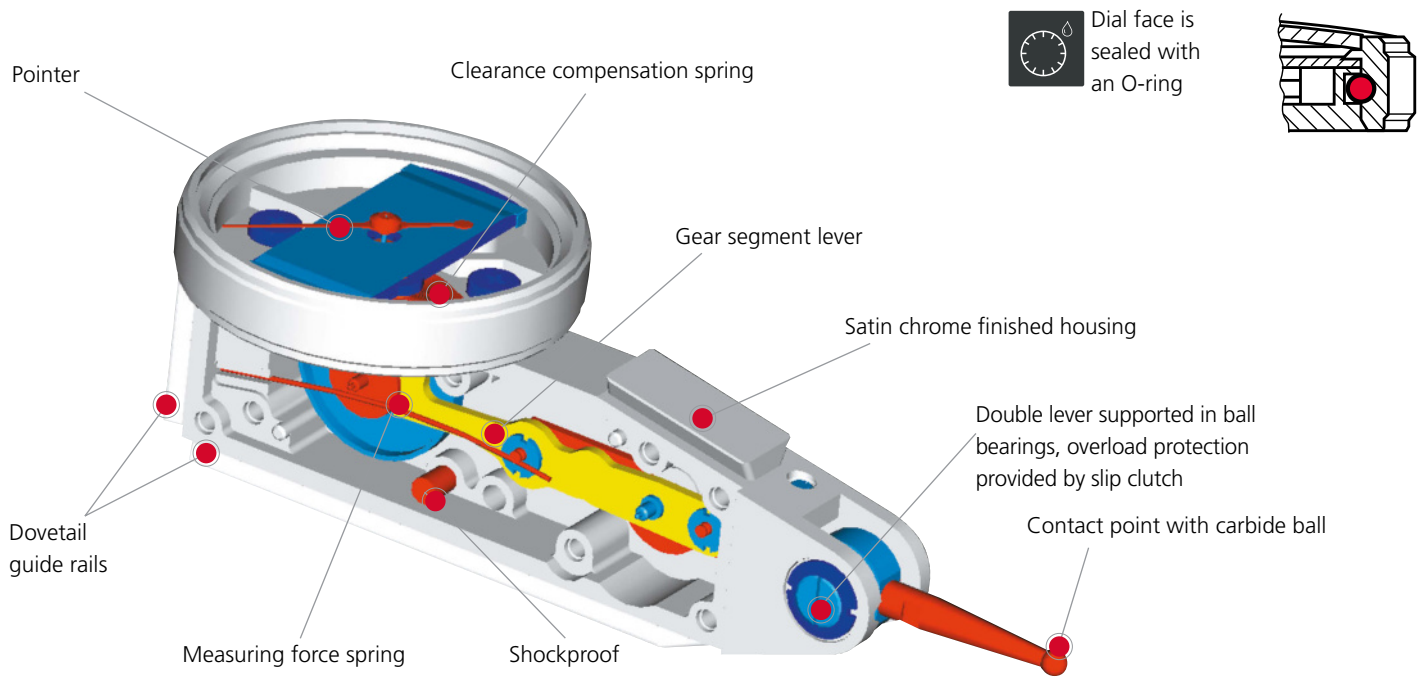

Dial face is sealed with an O-ring

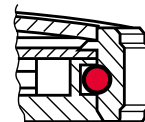

SHOCK PROOF

Mechanism

- Shockproof
- Anti-magnetic
- Movement bearings are jeweled with 8 precious stones

Styli with carbide contact points



Styli with ruby contact points



MarTest | Applications

Concentricity of a shaft



Concentricity of a sleeve



Centering of a bore



Aligning a surface



Testing parallelism



MarTest | Avoiding measuring errors

For accurate measurements the axis of the contact point must be perpendicular to the measuring direction (fig. 1). If this is not possible, it is necessary to multiply the reading on the dial with a correction factor, which depends on angle α (fig. 2). The correction factor is negligible for angles below 15°.

| Angle α | 15° | 30° | 45° | 60° |
|----------------|------|------|------|------|
| Corr. factor | 0.96 | 0.87 | 0.70 | 0.50 |

Example:

Angle α : 30° (estimated)

Reading on dial: 0.38 mm

Meas. values: $0.38 \times 0.87 = 0.33$ mm

Please use only the provided measuring insert length for the type of device (e.g. 800 S)

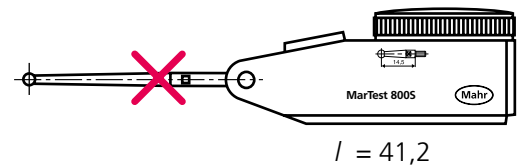
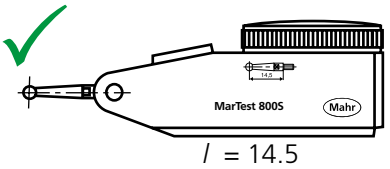
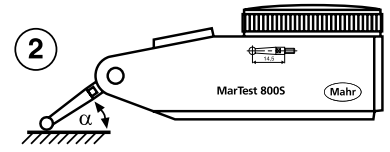
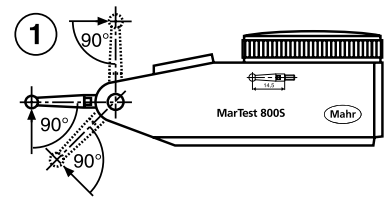

MarTest | Automatic switch of measuring direction

Measurement in both directions is possible without switch. The pointer moves clockwise. This guarantees clear and errorless reading.

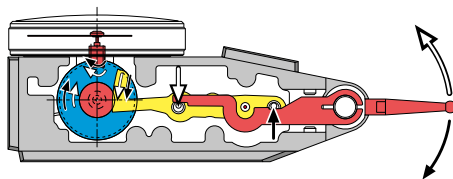

Functional depiction

MarTest | Metrological characteristics

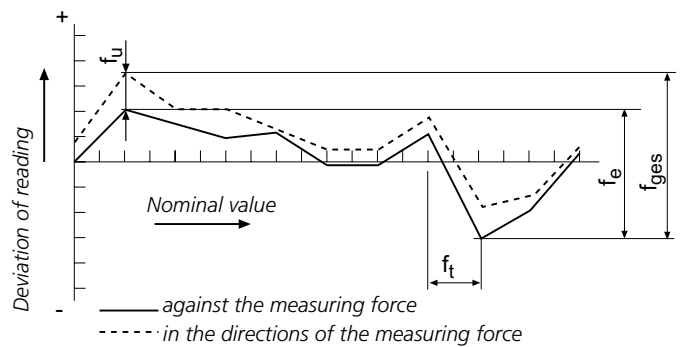

MarTest | Versions

Standard model
800 S

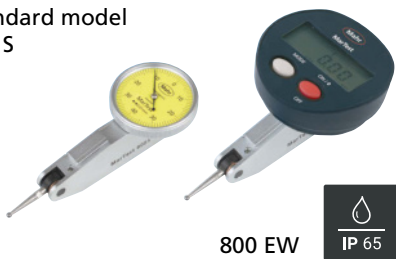

Extra long styli
800 SL



Higher resolution
800 SM



Larger measuring range
800 SR



Horizontal model
800 H



Vertical model
800 V



FEATURES

Standard model

- High-contrast dial face, sealed with O-ring
- Mineral glass viewing panel for best protection:
 - against cracking, scratching or damage caused by hot shavings
 - optimum resistance to solvents
- Matt chrome-plated protective casing with three integrated dovetail guide rails
- Shockproof measuring mechanism
- Anti-magnetic model
- Automatic adjustment to the contacting direction ensuring infallible readings
- Ball bearing mounted double lever
- Friction clutch overload protection
- **Package contains:** case, instruction manual, Spanner for changing the styli, stylus diameter \varnothing 2 mm, mounting shaft 800a8



Applications:

- Measurement of concentricity, alignment, parallelism and flatness
- Centering of bores and shafts
- Parallel or perpendicular alignment of workpieces

TECHNICAL DATA

| Order no. | 4305200 | 4307200 | 4307250 | 4301200 | 4301250 |
|----------------------------------|---------------|---------|------------------|------------|---------|
| Standard | DIN 2270 | | Factory standard | | |
| Type | 800 S | 800 SG | 800 SR | 800 SA | 800 SGA |
| Measuring range | mm ± 0.4 | | ± 0.8 | ± 0.25 | |
| Readings | mm | | 0.01 | | |
| Measuring surface | carbide | | | | |
| Scale diameter | mm 28 | 38 | | 28 | 38 |
| Type of dial face | 40–0–40 | | | 25–0–25 | |
| Dial color | Yellow | | | | |
| Measuring force | N | 0.15 | | 0.1 | |
| Range per rev. | mm | 0.8 | | 0.5 | |
| Deviation range f_e | μm | 10 | | 5 | |
| Total deviation range f_{ges} | μm | 13 | 14 | 8 | |
| Measuring value hysteresis f_u | μm | 3 | 4 | 3 | |
| Partial measuring span f_t | μm | | | | 5 |
| Repeatability f_w | μm | | | | 3 |

| Order no. | a | b | c | d | e | f | Measuring anvil length |
|-----------|------|----|------|------|----|----|------------------------|
| | mm | mm | mm | mm | mm | mm | mm |
| 4305200 | | 30 | 13.6 | 17.8 | 75 | 99 | 14.5 |
| 4307200 | 40.5 | | 13.6 | 17.8 | 75 | 99 | 14.5 |
| 4307250 | 40.5 | | 13.6 | 17.8 | 75 | 99 | 14.5 |
| 4301200 | | 30 | 13.6 | 17.8 | 75 | 99 | 14.5 |
| 4301250 | 40.5 | | 13.6 | 17.8 | 75 | 99 | 14.5 |

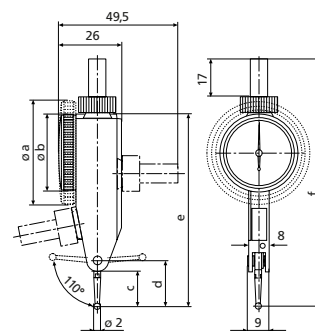

ACCESSORIES

| Order no. | Description | Type |
|-----------|---|---------|
| 4305870 | Stylus \varnothing 1.0 mm, carbide, $l = 14.5$ mm | 800 ts |
| 4305850 | Stylus \varnothing 2.0 mm, carbide, $l = 14.5$ mm | 800 ts |
| 4305871 | Stylus \varnothing 3.0 mm, carbide, $l = 14.5$ mm | 800 ts |
| 4309051 | Stylus \varnothing 2.0 mm, ruby, $l = 14.5$ mm | 800 tsr |
| 4305868 | Spanner | |

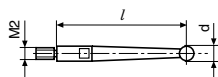

FEATURES

With long stylus, for measurements at poorly accessible measuring points

- High-contrast dial face, sealed with O-ring
- Mineral glass viewing panel for best protection:
 - against cracking, scratching or damage caused by hot shavings
 - optimum resistance to solvents
- Matt chrome-plated protective casing with three integrated dovetail guide rails
- Shockproof measuring mechanism
- Anti-magnetic model
- Automatic adjustment to the contacting direction ensuring infallible readings
- Ball bearing mounted double lever
- Friction clutch overload protection
- **Package contains:** case, instruction manual, Spanner for changing the styli, stylus diameter \varnothing 2 mm, mounting shaft 800a6 (800 SA/SGA/SGB), mounting shaft 800a8



Applications:

- Measurement of concentricity, alignment, parallelism and flatness
- Centering of bores and shafts
- Parallel or perpendicular alignment of workpieces

TECHNICAL DATA

| Order no. | 4301300 | 4306200 | 4306250 |
|----------------------------------|------------------|---------------|---------|
| Standard | Factory standard | | |
| Type | 800 SGB | 800 SL | 800 SGL |
| Measuring range | mm ± 0.5 | mm ± 0.25 | |
| Readings | mm | 0.01 | |
| Measuring surface | carbide | | |
| Scale diameter | mm 38 | 28 | 38 |
| Type of dial face | 50–0–50 | | 25–0–25 |
| Dial color | Yellow | | |
| Measuring force | N | 0.07 | |
| Range per rev. | mm 1 | 0.5 | |
| Deviation range f_e | μm | 10 | |
| Total deviation range f_{ges} | μm | 13 | |
| Measuring value hysteresis f_u | μm 4 | 5 | |
| Partial measuring span f_t | μm | 5 | |
| Repeatability f_w | μm | 3 | |

| Order no. | a | b | c | d | e | f | Measuring anvil length |
|-----------|------|----|------|------|-----|-----|------------------------|
| | mm | mm | mm | mm | mm | mm | mm |
| 4301300 | 40.5 | | 31.4 | 35.7 | 93 | 117 | 32.3 |
| 4306200 | | 30 | 40.3 | 44.6 | 102 | 126 | 41.24 |
| 4306250 | 40.5 | | 40.3 | 44.6 | 102 | 126 | 41.24 |

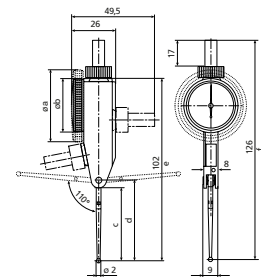

ACCESSORIES

| Order no. | Description | Type |
|-----------|--|---------|
| 4301851 | Stylus \varnothing 1.0 mm, carbide, l = 32.3 mm | 800 tb |
| 4301850 | Stylus \varnothing 2.0 mm, carbide, l = 32.3 mm | 800 tb |
| 4301852 | Stylus \varnothing 3.0 mm, carbide, l = 32.3 mm | 800 tb |
| 4309052 | Stylus \varnothing 2.0 mm, ruby, l = 32.3 mm | 800 tbr |
| 4305868 | Spanner | |
| 4306851 | Stylus \varnothing 1.0 mm, carbide, l = 41.24 mm | 800 tl |
| 4306850 | Stylus \varnothing 2.0 mm, carbide, l = 41.24 mm | 800 tl |
| 4306853 | Stylus \varnothing 3.0 mm, carbide, l = 41.24 mm | 800 tl |
| 4309053 | Stylus \varnothing 2.0 mm, ruby, l = 41.24 mm | 800 tlr |

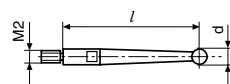

FEATURES

For high-precision measurements

- High-contrast dial face, sealed with O-ring
- Mineral glass viewing panel for best protection:
 - against cracking, scratching or damage caused by hot shavings
 - optimum resistance to solvents
- Matt chrome-plated protective casing with three integrated dovetail guide rails
- Shockproof measuring mechanism
- Anti-magnetic model
- Automatic adjustment to the contacting direction ensuring infallible readings
- Ball bearing mounted double lever
- Friction clutch overload protection
- **Package contains:** case, instruction manual, Spanner for changing the styli, stylus diameter \varnothing 2 mm, mounting shaft 800a8



Applications:

- Measurement of concentricity, alignment, parallelism and flatness
- Centering of bores and shafts
- Parallel or perpendicular alignment of workpieces

TECHNICAL DATA

| Order no. | 4308150 | 4308200 | 4308250 |
|----------------------------------|---------------|-----------|------------------|
| Standard | DIN 2270 | | Factory standard |
| Type | 800 SM | 800 SGM | 800 SRM |
| Measuring range | mm | ± 0.1 | ± 0.2 |
| Readings | mm | 0.002 | |
| Measuring surface | carbide | | |
| Scale diameter | mm | 28 | 38 |
| Type of dial face | 100–0–100 | | |
| Dial color | Yellow | | |
| Measuring force | N | 0.15 | |
| Range per rev. | mm | 0.2 | |
| Deviation range f_e | μm | 3 | |
| Total deviation range f_{ges} | μm | 4 | 5 |
| Measuring value hysteresis f_u | μm | 2 | 3 |
| Partial measuring span f_t | μm | 2 | |
| Repeatability f_w | μm | 1.5 | |

| Order no. | a | b | c | d | e | f | Measuring anvil length |
|-----------|------|----|------|------|----|----|------------------------|
| | mm | mm | mm | mm | mm | mm | mm |
| 4308150 | | 30 | 13.6 | 17.8 | 75 | 99 | 14.5 |
| 4308200 | 40.5 | | 13.6 | 17.8 | 75 | 99 | 14.5 |
| 4308250 | 40.5 | | 13.6 | 17.8 | 75 | 99 | 14.5 |

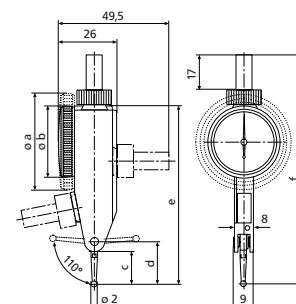

ACCESSORIES

| Order no. | Description | Type |
|-----------|---|---------|
| 4305870 | Stylus \varnothing 1.0 mm, carbide, $l = 14.5$ mm | 800 ts |
| 4305850 | Stylus \varnothing 2.0 mm, carbide, $l = 14.5$ mm | 800 ts |
| 4305871 | Stylus \varnothing 3.0 mm, carbide, $l = 14.5$ mm | 800 ts |
| 4309051 | Stylus \varnothing 2.0 mm, ruby, $l = 14.5$ mm | 800 tsr |
| 4305868 | Spanner | |

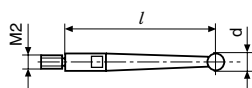

FEATURES

For high-precision measurements

- High-contrast dial face, sealed with O-ring
- Mineral glass viewing panel for best protection:
 - against cracking, scratching or damage caused by hot shavings
 - optimum resistance to solvents
- Matt chrome-plated protective casing with three integrated dovetail guide rails
- Shockproof measuring mechanism
- Anti-magnetic model
- Automatic adjustment to the contacting direction ensuring infallible readings
- Ball bearing mounted double lever
- Friction clutch overload protection
- **Package contains:** case, instruction manual, Spanner for changing the styli, stylus diameter \varnothing 2 mm, mounting shaft 800a8



Applications:

- Measurement of concentricity, alignment, parallelism and flatness
- Centering of bores and shafts
- Parallel or perpendicular alignment of workpieces

TECHNICAL DATA

| Order no. | 4308220 | | | | | |
|----------------------------------|------------------|------------|--|--|--|--|
| Standard | Factory standard | | | | | |
| Type | 800 SGE | | | | | |
| Measuring range | mm | ± 0.07 | | | | |
| Readings | mm | 0.001 | | | | |
| Measuring surface | carbide | | | | | |
| Scale diameter | mm | 38 | | | | |
| Type of dial face | 70–0–70 | | | | | |
| Dial color | Yellow | | | | | |
| Measuring force | N | 0.2 | | | | |
| Range per rev. | mm | 0.14 | | | | |
| Deviation range f_e | μm | 3 | | | | |
| Total deviation range f_{ges} | μm | 4 | | | | |
| Measuring value hysteresis f_u | μm | 2 | | | | |
| Partial measuring span f_t | μm | 2 | | | | |
| Repeatability f_w | μm | 1.5 | | | | |

| Order no. | a | c | d | e | f | Measuring anvil length |
|-----------|------|-----|------|----|----|------------------------|
| | mm | mm | mm | mm | mm | mm |
| 4308220 | 40.5 | 8.3 | 12.5 | 70 | 94 | 9.15 |

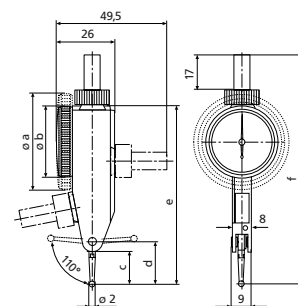

ACCESSORIES

| Order no. | Description | Type |
|-----------|--|---------|
| 4308851 | Stylus \varnothing 1.0 mm, carbide, $l = 9.1$ mm | 800 te |
| 4308850 | Stylus \varnothing 2.0 mm, carbide, $l = 9.1$ mm | 800 te |
| 4308852 | Stylus \varnothing 3.0 mm, carbide, $l = 9.1$ mm | 800 te |
| 4309050 | Stylus \varnothing 2.0 mm, ruby, $l = 9.1$ mm | 800 ter |
| 4305868 | Spanner | |

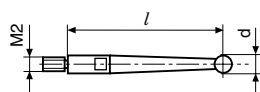

FEATURES

For high-precision measurements

- High-contrast dial face, sealed with O-ring
- Mineral glass viewing panel for best protection:
 - against cracking, scratching or damage caused by hot shavings
 - optimum resistance to solvents
- Matt chrome-plated protective casing with three integrated dovetail guide rails
- Shockproof measuring mechanism
- Anti-magnetic model
- Automatic adjustment to the contacting direction ensuring infallible readings
- Ball bearing mounted double lever
- Friction clutch overload protection
- **Package contains:** case, instruction manual, spanner for changing the styli, stylus diameter $\varnothing 2$ mm, mounting shaft 800a3/8



Applications:

- Measurement of concentricity, alignment, parallelism and flatness
- Centering of bores and shafts
- Parallel or perpendicular alignment of workpieces

TECHNICAL DATA

| Order no. | | 4308960 | 4308970 | 4308980 | 4308985 |
|----------------------------------|------|------------------|---------|--------------|--------------|
| Standard | | Factory standard | | | |
| Type | | 801 SM | 801 SGM | 801 SRM | 801 SGE |
| Measuring range | inch | $\pm .004''$ | | $\pm .008''$ | $\pm .004''$ |
| Readings | inch | 0,0001 | | | 0,00005 |
| Measuring surface | | carbide | | | |
| Scale diameter | inch | 1.1 | | 1.5 | |
| Type of dial face | | 4-0-4 | | | |
| Dial color | | Green | | | |
| Measuring force | N | 0.15 | | | |
| Range per turn | inch | 0.0080 | | | |
| Deviation range f_e | inch | 0.00012 | | | 0.0004 |
| Total deviation range f_{ges} | inch | 0.00016 | | 0.0002 | 0.0005 |
| Measuring value hysteresis f_u | inch | 0.00008 | | 0.00012 | |
| Partial measuring span f_t | inch | 0.00008 | | | 0.0002 |
| Repeatability f_w | inch | 0.0001 | | | |

| Order no. | a | b | c | d | e | f | Measuring anvil length |
|-----------|------|----|------|------|----|----|------------------------|
| | mm | mm | mm | mm | mm | mm | mm |
| 4308960 | | 30 | 13.6 | 17.8 | 75 | 99 | 14.5 |
| 4308970 | 40.5 | | 13.6 | 17.8 | 75 | 99 | 14.5 |
| 4308980 | 40.5 | | 13.6 | 17.8 | 75 | 99 | 14.5 |
| 4308985 | 40.5 | | 13.6 | 17.8 | 75 | 99 | 14.5 |

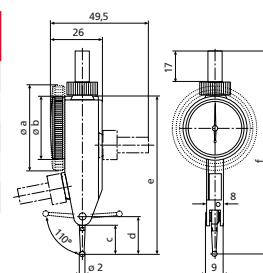

ACCESSORIES

| Order no. | Description | Type |
|-----------|---|---------|
| 4305850 | Stylus $\varnothing 2.0$ mm, carbide, $l = 14.5$ mm | 800 ts |
| 4305870 | Stylus $\varnothing 1.0$ mm, carbide, $l = 14.5$ mm | 800 ts |
| 4305871 | Stylus $\varnothing 3.0$ mm, carbide, $l = 14.5$ mm | 800 ts |
| 4309051 | Stylus $\varnothing 2.0$ mm, ruby, $l = 14.5$ mm | 800 tsr |
| 4305868 | Spanner | |

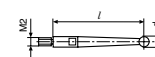

Test indicator

FEATURES

Standard model

- High-contrast dial face, sealed with O-ring
- Mineral glass viewing panel for best protection:
 - against cracking, scratching or damage caused by hot shavings
 - optimum resistance to solvents
- Matt chrome-plated protective casing with three integrated dovetail guide rails
- Shockproof measuring mechanism
- Anti-magnetic model
- Automatic adjustment to the contacting direction ensuring infallible readings
- Ball bearing mounted double lever
- Friction clutch overload protection
- **Package contains:** case, instruction manual, spanner for changing the styli, stylus diameter $\varnothing 2$ mm, mounting shaft 800a3/8



Applications:

- Measurement of concentricity, alignment, parallelism and flatness
- Centering of bores and shafts
- Parallel or perpendicular alignment of workpieces

TECHNICAL DATA

| Order no. | | 4305950 | 4305960 | 4307950 | 4307960 | 4307970 |
|----------------------------------|------|------------------|--------------|---------|--------------|--------------|
| Standard | | Factory standard | | | | |
| Type | | 801 S | 801 S1 | 801 SG | 801 SR | 801 SGI |
| Measuring range | mm | | | | | $\pm 0,3$ |
| Measuring range | inch | | $\pm .015''$ | | $\pm .030''$ | $\pm .015''$ |
| Readings | inch | | | 0.0005 | | |
| Readings | | | | | | 0.01 |
| Measuring surface | | | | carbide | | |
| Scale diameter | inch | 1.1 | 1.5 | 1.1 | 1.5 | |
| Type of dial face | | | | 15-0-15 | | |
| Dial color | | | | Green | | |
| Measuring force | N | | | 0.15 | | |
| Range per turn | mm | | | | | 0.6 |
| Range per turn | inch | | | 0.0300 | | |
| Deviation range f_e | inch | | | 0.0004 | | |
| Total deviation range f_{ges} | inch | | | 0.0005 | | |
| Measuring value hysteresis f_u | inch | | 0.00012 | | 0.00016 | 0.00012 |
| Partial measuring span f_t | inch | | | 0.0002 | | |
| Repeatability f_w | inch | | | 0.0001 | | |

| Order no. | a | b | c | d | e | f | Measuring anvil length |
|-----------|------|----|------|------|----|----|------------------------|
| | mm | mm | mm | mm | mm | mm | mm |
| 4305950 | | 30 | 13.6 | 17.8 | 75 | 99 | 14.5 |
| 4305960 | | 30 | 13.6 | 17.8 | 75 | 99 | 14.5 |
| 4307950 | 40.5 | | 13.6 | 17.8 | 75 | 99 | 14.5 |
| 4307960 | 40.5 | | 13.6 | 17.8 | 75 | 99 | 14.5 |
| 4307970 | 40.5 | | 13.6 | 17.8 | 75 | 99 | 14.5 |

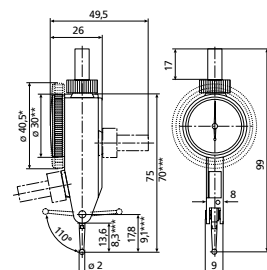

ACCESSORIES

| Order no. | Description | Type |
|-----------|---|---------|
| 4305870 | Stylus $\varnothing 1.0$ mm, carbide, $l = 14.5$ mm | 800 ts |
| 4305850 | Stylus $\varnothing 2.0$ mm, carbide, $l = 14.5$ mm | 800 ts |
| 4305871 | Stylus $\varnothing 3.0$ mm, carbide, $l = 14.5$ mm | 800 ts |
| 4309051 | Stylus $\varnothing 2.0$ mm, ruby, $l = 14.5$ mm | 800 tsr |
| 4305868 | Spanner | |

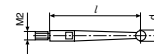

FEATURES

With long stylus, for measurements at poorly accessible measuring points

- High-contrast dial face, sealed with O-ring
- Mineral glass viewing panel for best protection:
 - against cracking, scratching or damage caused by hot shavings
 - optimum resistance to solvents
- Matt chrome-plated protective casing with three integrated dovetail guide rails
- Shockproof measuring mechanism
- Anti-magnetic model
- Automatic adjustment to the contacting direction ensuring infallible readings
- Ball bearing mounted double lever
- Friction clutch overload protection
- **Package contains:** case, instruction manual, spanner for changing the styli, stylus diameter \varnothing 2 mm, mounting shaft 800a3/8



Applications:

- Measurement of concentricity, alignment, parallelism and flatness
- Centering of bores and shafts
- Parallel or perpendicular alignment of workpieces

TECHNICAL DATA

| Order no. | 4306950 | 4306960 | |
|----------------------------------|---------|------------------|-----|
| Standard | | Factory standard | |
| Type | 801 SL | 801 SGL | |
| Measuring range | inch | $\pm .010''$ | |
| Readings | inch | 0,0005 | |
| Measuring surface | | carbide | |
| Scale diameter | inch | 1.1 | 1.5 |
| Type of dial face | | 10–0–10 | |
| Dial color | | Green | |
| Measuring force | N | 0.07 | |
| Range per turn | inch | 0.0200 | |
| Deviation range f_e | inch | 0.0004 | |
| Total deviation range f_{ges} | inch | 0.0005 | |
| Measuring value hysteresis f_u | inch | 0.0002 | |
| Partial measuring span f_t | inch | 0.0002 | |
| Repeatability f_w | inch | 0.0001 | |

TECHNICAL DATA

| Order no. | a | b | c | d | e | f | Measuring anvil length |
|-----------|------|----|------|------|-----|-----|------------------------|
| | mm | mm | mm | mm | mm | mm | mm |
| 4306950 | | 30 | 40.3 | 44.6 | 102 | 126 | 41.24 |
| 4306960 | 40.5 | | 40.3 | 44.6 | 102 | 126 | 41.24 |

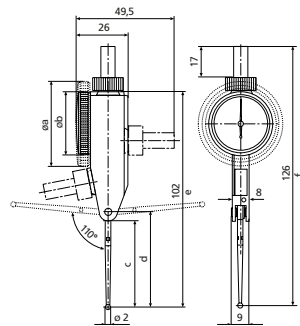

ACCESSORIES

| Order no. | Description | Type |
|-----------|--|---------|
| 4306851 | Stylus \varnothing 1.0 mm, carbide, $l = 41.24$ mm | 800 tl |
| 4306850 | Stylus \varnothing 2.0 mm, carbide, $l = 41.24$ mm | 800 tl |
| 4306853 | Stylus \varnothing 3.0 mm, carbide, $l = 41.24$ mm | 800 tl |
| 4309053 | Stylus \varnothing 2.0 mm, ruby, $l = 41.24$ mm | 800 tlr |
| 4305868 | Spanner | |

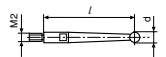

FEATURES

Vertical model

- High-contrast dial face, sealed with O-ring
- Mineral glass viewing panel for best protection:
 - against cracking, scratching or damage caused by hot shavings
 - optimum resistance to solvents
- Matt chrome-plated protective casing with three integrated dovetail guide rails
- Shockproof measuring mechanism
- Anti-magnetic model
- Automatic adjustment to the contacting direction ensuring infallible readings
- Ball bearing mounted double lever
- Friction clutch overload protection
- **Package contains:** case, instruction manual, Spanner for changing the styli, stylus diameter \varnothing 2 mm, mounting shaft 800a8



Applications:

- Measurement of concentricity, alignment, parallelism and flatness
- Centering of bores and shafts
- Parallel or perpendicular alignment of workpieces

TECHNICAL DATA

| Order no. | | | 4302200 |
|----------------------------------|---------|--|-----------|
| Standard | | | DIN 2270 |
| Type | | | 800 V |
| Measuring range | mm | | \pm 0.4 |
| Readings | mm | | 0.01 |
| Measuring surface | | | carbide |
| Scale diameter | mm | | 28 |
| Type of dial face | | | 40–0–40 |
| Dial color | | | Yellow |
| Measuring force | N | | 0.2 |
| Range per rev. | mm | | 0.8 |
| Deviation range f_e | μ m | | 10 |
| Total deviation range f_{ges} | μ m | | 13 |
| Measuring value hysteresis f_u | μ m | | 3 |
| Partial measuring span f_t | μ m | | 5 |
| Repeatability f_w | μ m | | 3 |

| Order no. | b | Measuring anvil length |
|-----------|----|------------------------|
| | mm | mm |
| 4302200 | 30 | 14.5 |

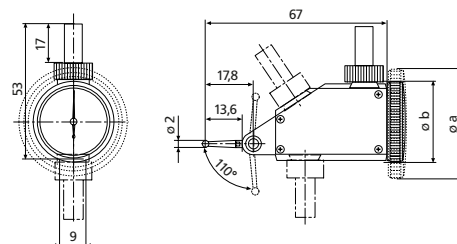

ACCESSORIES

| Order no. | Description | Type |
|-----------|---|---------|
| 4305870 | Stylus \varnothing 1.0 mm, carbide, l = 14.5 mm | 800 ts |
| 4305850 | Stylus \varnothing 2.0 mm, carbide, l = 14.5 mm | 800 ts |
| 4305871 | Stylus \varnothing 3.0 mm, carbide, l = 14.5 mm | 800 ts |
| 4309051 | Stylus \varnothing 2.0 mm, ruby, l = 14.5 mm | 800 tsr |
| 4305868 | Spanner | |

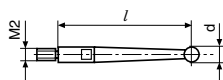

FEATURES

Vertical model

- High-contrast dial face, sealed with O-ring
- Mineral glass viewing panel for best protection:
 - against cracking, scratching or damage caused by hot shavings
 - optimum resistance to solvents
- Matt chrome-plated protective casing with three integrated dovetail guide rails
- Shockproof measuring mechanism
- Anti-magnetic model
- Automatic adjustment to the contacting direction ensuring infallible readings
- Ball bearing mounted double lever
- Friction clutch overload protection
- **Package contains:** case, instruction manual, Spanner for changing the styli, stylus diameter $\varnothing 2$ mm, mounting shaft 800a8



Applications:

- Measurement of concentricity, alignment, parallelism and flatness
- Centering of bores and shafts
- Parallel or perpendicular alignment of workpieces

TECHNICAL DATA

| Order no. | | 4302250 |
|----------------------------------|---------------|-----------|
| Standard | | DIN 2270 |
| Type | | 800 VGM |
| Measuring range | mm | ± 0.1 |
| Readings | mm | 0.002 |
| Measuring surface | | carbide |
| Scale diameter | mm | 38 |
| Type of dial face | | 100-0-100 |
| Dial color | | Yellow |
| Measuring force | N | 0.25 |
| Range per rev. | mm | 0.2 |
| Deviation range f_e | μm | 3 |
| Total deviation range f_{ges} | μm | 4 |
| Measuring value hysteresis f_u | μm | 2 |
| Partial measuring span f_t | μm | 2 |
| Repeatability f_w | μm | 1.5 |

| Order no. | a | Measuring anvil length |
|-----------|------|------------------------|
| | mm | mm |
| 4302250 | 40.5 | 14.5 |

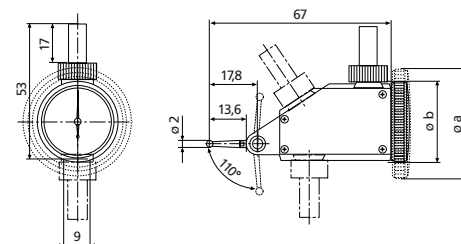

ACCESSORIES

| Order no. | Description | Type |
|-----------|---|---------|
| 4305870 | Stylus $\varnothing 1.0$ mm, carbide, $l = 14.5$ mm | 800 ts |
| 4305850 | Stylus $\varnothing 2.0$ mm, carbide, $l = 14.5$ mm | 800 ts |
| 4305871 | Stylus $\varnothing 3.0$ mm, carbide, $l = 14.5$ mm | 800 ts |
| 4309051 | Stylus $\varnothing 2.0$ mm, ruby, $l = 14.5$ mm | 800 tsr |
| 4305868 | Spanner | |

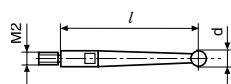

FEATURES

Vertical model

- High-contrast dial face, sealed with O-ring
- Mineral glass viewing panel for best protection:
 - against cracking, scratching or damage caused by hot shavings
 - optimum resistance to solvents
- Matt chrome-plated protective casing with three integrated dovetail guide rails
- Shockproof measuring mechanism
- Anti-magnetic model
- Automatic adjustment to the contacting direction ensuring infallible readings
- Ball bearing mounted double lever
- Friction clutch overload protection
- **Package contains:** case, instruction manual, spanner for changing the styli, stylus diameter $\varnothing 2$ mm, mounting shaft 800a3/8



Applications:

- Measurement of concentricity, alignment, parallelism and flatness
- Centering of bores and shafts
- Parallel or perpendicular alignment of workpieces

TECHNICAL DATA

| Order no. | 4302960 | |
|----------------------------------|---------|------------------|
| Standard | | Factory standard |
| Type | | 801 VGM |
| Measuring range | inch | $\pm .004''$ |
| Readings | inch | 0,0001 |
| Measuring surface | | carbide |
| Scale diameter | inch | 1.5 |
| Type of dial face | | 4-0-4 |
| Dial color | | Green |
| Measuring force | N | 0.25 |
| Range per turn | inch | 0.0080 |
| Deviation range f_e | inch | 0.00012 |
| Total deviation range f_{ges} | inch | 0.00016 |
| Measuring value hysteresis f_u | inch | 0.00008 |
| Partial measuring span f_t | inch | 0.00008 |
| Repeatability f_w | inch | 0.0001 |

| Order no. | a | Measuring anvil length |
|-----------|------|------------------------|
| | mm | mm |
| 4302960 | 40.5 | 14.5 |

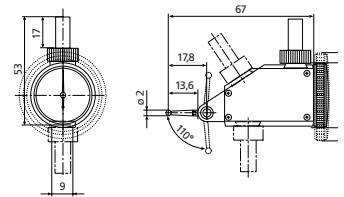

ACCESSORIES

| Order no. | Description | Type |
|-----------|---|---------|
| 4305870 | Stylus $\varnothing 1.0$ mm, carbide, $l = 14.5$ mm | 800 ts |
| 4305850 | Stylus $\varnothing 2.0$ mm, carbide, $l = 14.5$ mm | 800 ts |
| 4305871 | Stylus $\varnothing 3.0$ mm, carbide, $l = 14.5$ mm | 800 ts |
| 4309051 | Stylus $\varnothing 2.0$ mm, ruby, $l = 14.5$ mm | 800 tsr |
| 4305868 | Spanner | |

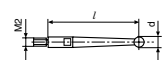

FEATURES

Vertical model

- High-contrast dial face, sealed with O-ring
- Mineral glass viewing panel for best protection:
 - against cracking, scratching or damage caused by hot shavings
 - optimum resistance to solvents
- Matt chrome-plated protective casing with three integrated dovetail guide rails
- Shockproof measuring mechanism
- Anti-magnetic model
- Automatic adjustment to the contacting direction ensuring infallible readings
- Ball bearing mounted double lever
- Friction clutch overload protection
- **Package contains:** case, instruction manual, spanner for changing the styli, stylus diameter \varnothing 2 mm, mounting shaft 800a3/8



Applications:

- Measurement of concentricity, alignment, parallelism and flatness
- Centering of bores and shafts
- Parallel or perpendicular alignment of workpieces

TECHNICAL DATA

| Order no. | 4302950 | |
|----------------------------------|------------------|--------------|
| Standard | Factory standard | |
| Type | 801 V | |
| Measuring range | inch | $\pm .015''$ |
| Readings | inch | 0,0005 |
| Measuring surface | carbide | |
| Scale diameter | inch | 1.1 |
| Type of dial face | 15–0–15 | |
| Dial color | Green | |
| Measuring force | N | 0.2 |
| Range per turn | inch | 0.0300 |
| Deviation range f_e | inch | 0.0004 |
| Total deviation range f_{ges} | inch | 0.0005 |
| Measuring value hysteresis f_u | inch | 0.00012 |
| Partial measuring span f_t | inch | 0.0002 |
| Repeatability f_w | inch | 0.0001 |

| Order no. | b | Measuring anvil length |
|-----------|----|------------------------|
| | mm | mm |
| 4302950 | 30 | 14.5 |

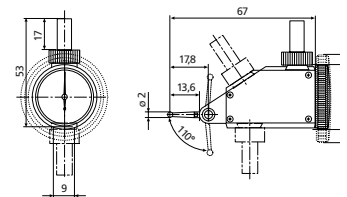

ACCESSORIES

| Order no. | Description | Type |
|-----------|---|---------|
| 4305870 | Stylus \varnothing 1.0 mm, carbide, $l = 14.5$ mm | 800 ts |
| 4305850 | Stylus \varnothing 2.0 mm, carbide, $l = 14.5$ mm | 800 ts |
| 4305871 | Stylus \varnothing 3.0 mm, carbide, $l = 14.5$ mm | 800 ts |
| 4309051 | Stylus \varnothing 2.0 mm, ruby, $l = 14.5$ mm | 800 tsr |
| 4305868 | Spanner | |

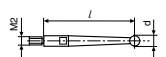

FEATURES

Horizontal model

- High-contrast dial face, sealed with O-ring
- Mineral glass viewing panel for best protection:
 - against cracking, scratching or damage caused by hot shavings
 - optimum resistance to solvents
- Matt chrome-plated protective casing with three integrated dovetail guide rails
- Shockproof measuring mechanism
- Anti-magnetic model
- Automatic adjustment to the contacting direction ensuring infallible readings
- Ball bearing mounted double lever
- Friction clutch overload protection
- **Package contains:** case, instruction manual, Spanner for changing the styli, stylus diameter \varnothing 2 mm, mounting shaft 800a8



Applications:

- Measurement of concentricity, alignment, parallelism and flatness
- Centering of bores and shafts
- Parallel or perpendicular alignment of workpieces

TECHNICAL DATA

| Order no. | | | 4303200 |
|----------------------------------|---------|--|-----------|
| Standard | | | DIN 2270 |
| Type | | | 800 H |
| Measuring range | mm | | \pm 0.4 |
| Readings | mm | | 0.01 |
| Measuring surface | | | carbide |
| Scale diameter | mm | | 28 |
| Type of dial face | | | 40–0–40 |
| Dial color | | | Yellow |
| Measuring force | N | | 0.25 |
| Range per rev. | mm | | 0.8 |
| Deviation range f_e | μ m | | 10 |
| Total deviation range f_{ges} | μ m | | 13 |
| Measuring value hysteresis f_u | μ m | | 3 |
| Partial measuring span f_t | μ m | | 5 |
| Repeatability f_w | μ m | | 3 |

| Order no. | Measuring anvil length |
|-----------|------------------------|
| | mm |
| 4303200 | 14.5 |

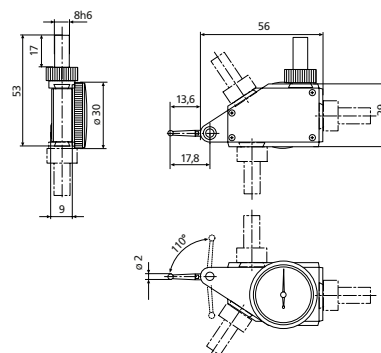

ACCESSORIES

| Order no. | Description | Type |
|-----------|---|---------|
| 4305870 | Stylus \varnothing 1.0 mm, carbide, l = 14.5 mm | 800 ts |
| 4305850 | Stylus \varnothing 2.0 mm, carbide, l = 14.5 mm | 800 ts |
| 4305871 | Stylus \varnothing 3.0 mm, carbide, l = 14.5 mm | 800 ts |
| 4309051 | Stylus \varnothing 2.0 mm, ruby, l = 14.5 mm | 800 tsr |
| 4305868 | Spanner | |

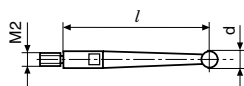

MarTest 800 EW / 800 EWL

Digital test indicator



FUNCTIONS

- ON/OFF
- RESET (set display to zero)
- mm/inch
- MAX/MIN memory for searching the reversal point
- (MAX-MIN) for testing flatness and concentricity

FEATURES

- Inductive measuring system
- Battery life approx. 2 years
- Operating unit is protected against coolants and lubricants, protection class IP65
- Combined analog and digital display
- Operating and display unit (bezel) can be rotated through 360°
- Satin chrome finished housing with 3 dovetail guideways
- Shockproof
- Movement bearings are jeweled
- Automatic matching to sensing direction
- Anti-magnetic
- Double lever supported in ball bearings
- Overload protection provided by slip clutch
- **Software:** MarCom Professional free download: www.mahr.com/marcom (only for Mahr data cables and wireless systems with USB and RS-232 interface)
- **Data interface:** Opto RS-232C, USB
- **Energy supply:** Battery life approx. 3 years
- **Battery type:** CR 2032 (3V Lithium)
- **IP protection category:** IP 65
- **Package contains:** mounting shaft 800a8, Spanner for changing the styli, stylus diameter $\varnothing 2$ mm, case



Applications:

- Measurement of concentricity, alignment, parallelism and flatness
- Centering of bores and shafts
- Parallel or perpendicular alignment of workpieces

TECHNICAL DATA

| Order no. | 4305120 | 4306120 |
|----------------------------------|---------------------------|--------------|
| Standard | Factory standard | |
| Type | 800 EW | 800 EWL |
| Measuring range | mm ± 0.4 | ± 0.25 |
| Measuring range | inch $\pm .015''$ | $\pm .010''$ |
| Resolution | mm / inch 0.001 / .00005" | |
| Measuring surface | carbide | |
| Measuring force | N 0.13 | 0.07 |
| Deviation range f_e | μm 10 | |
| Total deviation range f_{ges} | μm 13 | |
| Measuring value hysteresis f_u | μm 5 | 7 |
| Partial measuring span f_t | μm 5 | |
| Repeatability f_w | μm 3 | |

| Order no. | c | d | e | f | Mounting shaft | Measuring anvil length |
|-----------|------|------|-----|-----|----------------|------------------------|
| | mm | mm | mm | mm | mm | mm |
| 4305120 | 13.6 | 17.8 | 75 | 99 | 8 | 14.5 |
| 4306120 | 40.3 | 44.6 | 102 | 126 | 8 | 41.24 |

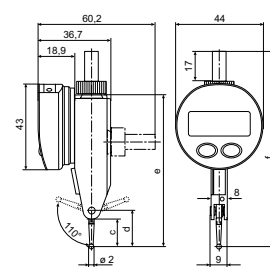

ACCESSORIES

| Order no. | Description | Type |
|-----------|--|---------|
| 4305870 | Stylus $\varnothing 1.0$ mm, carbide, $l = 14.5$ mm | 800 ts |
| 4305850 | Stylus $\varnothing 2.0$ mm, carbide, $l = 14.5$ mm | 800 ts |
| 4305871 | Stylus $\varnothing 3.0$ mm, carbide, $l = 14.5$ mm | 800 ts |
| 4102520 | Battery 3 V, CR 2032 | |
| 4305122 | Data connection cable RS232C (2 m) | 800 EWr |
| 4305121 | 800 EWu data connection cable USB (2 m) | 800 EWu |
| 4309051 | Stylus $\varnothing 2.0$ mm, ruby, $l = 14.5$ mm | 800 tsr |
| 4306850 | Stylus $\varnothing 2.0$ mm, carbide, $l = 41.24$ mm | 800 tl |
| 4306851 | Stylus $\varnothing 1.0$ mm, carbide, $l = 41.24$ mm | 800 tl |
| 4306853 | Stylus $\varnothing 3.0$ mm, carbide, $l = 41.24$ mm | 800 tl |
| 4309053 | Stylus $\varnothing 2.0$ mm, ruby, $l = 41.24$ mm | 800 tlr |

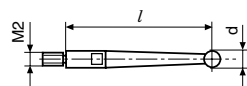

MarTest 800 a4 / 800 a6 / 800 a8 / 800 a3/8 / 800 a1/4"

Mounting shaft

FEATURES

- Clamping shafts on the housing can be moved on dovetail guide rails
- Clamping in any position with milled nut (no tools required)



TECHNICAL DATA

| Order no. | Type |
|-----------|-----------|
| 4305885 | 800 a4 |
| 4301865 | 800 a6 |
| 4305865 | 800 a8 |
| 4305875 | 800 a3/8 |
| 4305895 | 800 a1/4" |

| Order no. | Mounting shaft | Mounting shaft |
|-----------|----------------|----------------|
| | inch | mm |
| 4305885 | | 4 |
| 4301865 | | 6 |
| 4305865 | | 8 |
| 4305875 | 0.375 | |
| 4305895 | 0.25 | |

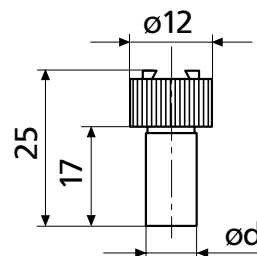

MarTest 800 h1

Holder

FEATURES

- Used for holding dial test indicator measuring devices on machine tools in conjunction with the 800k universal clamp



TECHNICAL DATA

| Order no. | Type |
|-----------|--------|
| 4305888 | 800 h1 |

| Order no. | a | b | Cross-section |
|-----------|----|-----|---------------|
| | mm | mm | mm |
| 4305888 | 9 | 100 | 9x9 |

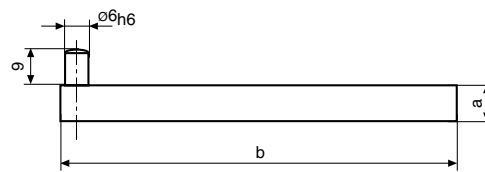

ACCESSORIES

| Order no. | Description | Type |
|-----------|---|--------|
| 4305891 | Universal clamp, $\varnothing d1 = 4$ mm, $\varnothing d2 = 8$ mm, dovetail clamp | 800 k8 |

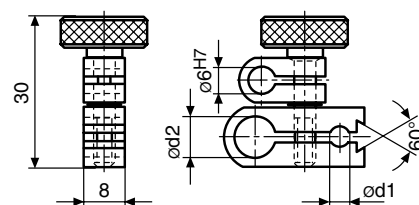

800 k8; 800 k3/8"

MarTest 800 hs8

Universal holder with dovetail clamp

FEATURES

- For aligning and centering workpieces on machine tools
- Pivoting holding clamp for dovetail



TECHNICAL DATA

| Order no. | Type |
|-----------|---------|
| 4305886 | 800 hs8 |

| Order no. | a | b | c |
|-----------|-----|-----|----|
| | mm | mm | mm |
| 4305886 | 100 | 124 | 8 |

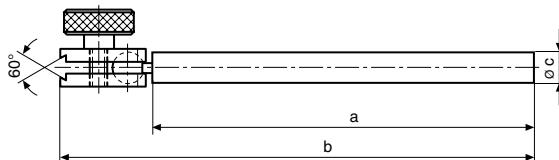

MarTest 801 v

Measuring and centering arm

FEATURES

- For aligning and centering workpieces on machine tools
- Pivoting holding clamp with integrated precision adjustment
- Stainless steel struts



TECHNICAL DATA

| Order no. | Type |
|-----------|-------|
| 4309070 | 801 v |

| Order no. | Mounting hole | Swivel range of mounting clamp |
|-----------|---------------|--------------------------------|
| 4309070 | 8 mm | 180 |

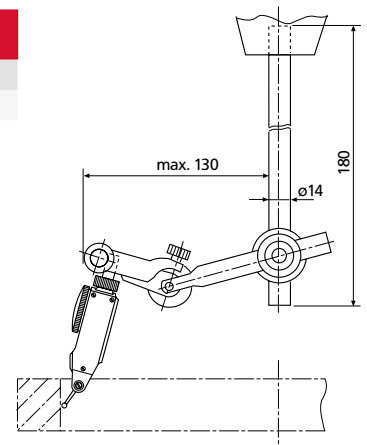

ACCESSORIES

| Order no. | Description | Type |
|-----------|-----------------------------------|--------|
| 4305865 | Mounting shaft \varnothing 8 mm | 800 a8 |

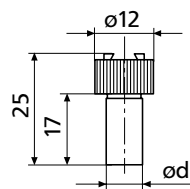

800 a8; 800 a1/4";
800 a4; 800 a3/8; 800 a6

MarTest 801 p

Measuring stand

FEATURES

Perfect for measurements with small dial indicators and dial test indicator measuring devices.

- Pivoting holder with \varnothing 8 and \varnothing 4 mm mount and dovetail profile for dial test indicator measuring devices
- Stainless steel column
- Base with V-groove



TECHNICAL DATA

| Order no. | Type | | | | |
|-----------|-------|--|--|--|--|
| 4309090 | 801 p | | | | |

| Order no. | Mounting hole | Base surface | Height | V-angle | Column \varnothing |
|-----------|---------------|--------------|--------|------------|----------------------|
| 4309090 | 4 and 8 mm | 65 x 40 mm | mm | $^{\circ}$ | mm |
| | | | 150 | 140 | 8 |

MarTest 800 b

Universal centering support frame

FEATURES

- For aligning and centering workpieces on machine tools
- Pivoting holding clamp



TECHNICAL DATA

| Order no. | Type |
|-----------|-------|
| 4305893 | 800 b |

| Order no. | Mounting hole |
|-----------|---------------|
| 4305893 | 4 mm |

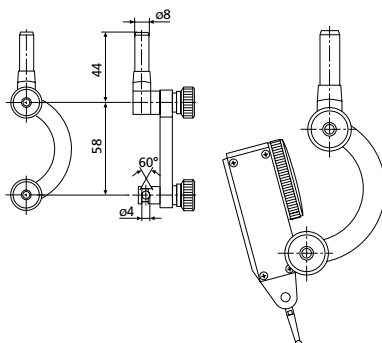

ACCESSORIES

| Order no. | Description | Type |
|-----------|-----------------------------------|--------|
| 4305885 | Mounting shaft \varnothing 4 mm | 800 a4 |

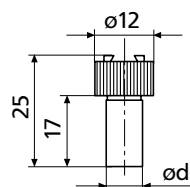

FUNCTIONS

- ON/OFF
- Auto OFF after 2 hours

FEATURES

- Excellent readability thanks to combined display:
 - bar graph for dynamic path information
 - digital display for exact readings
- Can be controlled independently of a machine tool
- Large working range in all axes (X, Y, Z) prevents damage to the stylus by contacting errors
- Compact metal housing and long probe arm
- Shockproof movement
- **Energy supply:** Battery life approx. 3 years
- **Battery type:** CR 2032 (3V Lithium)
- **IP protection category:** IP 65
- **Package contains:** battery, instruction manual, stylus 802 EWt

Applications:

Can be used on milling and CNC machines to

- Determine the zero position on workpieces
- Determine the center of bores
- Determine and correct the alignment of a workpiece and for the measurement of:
 - Lengths
 - Depths



TECHNICAL DATA

| Order no. | 4304300 | |
|---|---------|------------------|
| Standard | | Factory standard |
| Type | | 802 EW |
| Measuring surface | | carbide |
| Working areas, X-, Y-, Z-axis | | -2 to 4 mm |
| Repeatability at zero point, unidirectional | inch | ± 0.005 mm |

| Order no. | Mounting shaft |
|-----------|----------------|
| | mm |
| 4304300 | 16 |

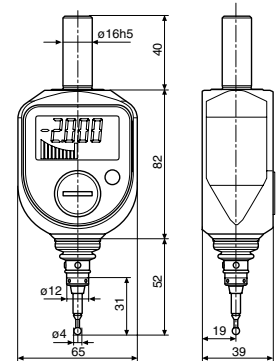

ACCESSORIES

| Order no. | Description | Type |
|-----------|--|---------|
| 4304320 | Stylus \varnothing 4.0 mm, l = 31 mm | 802 EWt |
| 4102520 | Battery 3 V, CR 2032 | |

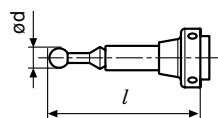

FEATURES

- Large, high contrast dial face
- Can be controlled independently of a machine tool
- Large working range in all axes (X, Y, Z) prevents damage to the stylus by contacting errors
- Compact metal housing and long probe arm
- High accuracy and linearity
- Shockproof and waterproof, ideal for the use on a machine with a tool changer
- **IP protection category:** IP 67
- **Package contains:** battery, instruction manual, stylus 802 EWt

Applications:

Can be used on milling and CNC machines to:

- Determine the zero position on workpieces
- Determine the center of bores
- Determine and correct the alignment of a workpiece and for the measurement of:
 - Lengths
 - Depths



TECHNICAL DATA

| | | |
|--|----------------|------------------|
| Order no. | 4304311 | |
| Standard | | Factory standard |
| Type | | 802 NW |
| Readings | | 0.01 |
| Measuring surface | | carbide |
| Working areas, X-, Y-, Z-axis | | 6.6 mm |
| Repeatability at zero point, unidirectional | inch | ± 0.01 mm |

| | |
|------------------|-----------------------|
| Order no. | Mounting shaft |
| | mm |
| 4304311 | 16 |

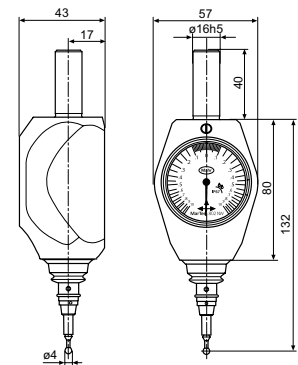

ACCESSORIES

| Order no. | Description | Type |
|-----------|--|---------|
| 4304320 | Stylus \varnothing 4.0 mm, l = 31 mm | 802 EWt |
| 4304321 | Stylus \varnothing 6 mm, l = 56.6 mm | 802 NWt |

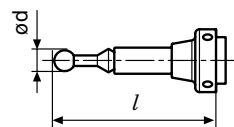

MarCator | Dial digital indicators

Whether mechanical or digital, dial indicators rank as some of the most commonly used measuring probes. MarCator dial indicators offer accurate measuring results, simple controls and a rugged construction for use on the shop floor.



| | |
|--|------------|
| Overview MarCator dial indicators | 130 |
| Digital dial indicators | |
| MarCator 1075 R | 132 |
| Standard versions with numerical display | |
| MarCator 1086 Ri / 1086 WRi / 1086 R / 1086 WR / 1086 R-HR | 133 |
| With dynamic measuring functions and tolerance display | |
| MarCator 1087 Ri / 1087 R / 1087 R-HR | 140 |
| With combined numerical and digital display | |
| MarCator 1087 BRi / 1087 BR | 143 |
| For 2-point comparative measuring equipment | |
| Dial indicators with scale display | |
| MarCator 803 S / 803 A / 805 A | 145 |
| Small dial indicators | |
| MarCator 810 S / 810 A / 810 AT / 810 SV / 810 AU | 146 |
| Standard versions | |
| MarCator 810 SM / 810 SRM / 810 AX | 147 |
| Safety dial indicator with scale graduation 0.001 mm / 0.1 mm | |
| MarCator 810 SW / 803 SW | 149 |
| Waterproof version (IP54) | |
| MarCator 810 AZ / 803 AZ | 150 |
| Dial indicator | |
| MarCator 810 SB / 803 SB | 151 |
| Version with limited measuring range | |
| MarCator 810 AG | 152 |
| Large dial indicator | |
| Measuring anvils and accessories for dial indicators and dial comparators | 153 |
| MarCator 841 G | 158 |
| Straight holder | |
| MarCator 841 W | 159 |
| Angular holder | |
| MarCator 943 | 160 |
| Sensor level | |
| MarCator 837 | 161 |
| Dial indicator depth measuring bridge | |
| Dial indicators | 162 |
| MarCator 400B-3 / 400B-4 | 181 |
| Mobile dial calibrator | |

MarCator | Digital and dial indicators

Digital dial indicators with Reference System and Integrated Wireless

With MarCator 1086 Ri and 1087 Ri, Mahr sets standards in the dial gage product segment:

With the Reference System, MarCator indicators are immediately ready for measurement, as the zero position once set remains stored for all further measurements. And if you need to document your data, Integrated Wireless, the integrated energy-efficient radio system, offers you the optimal solution for transferring the measured values to the PC.

Clear display

Tolerance display with measured value display. Display of the current value and the indicated tolerance.

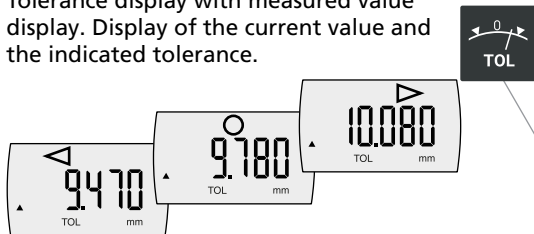

Tolerance display without measured value display. Tolerance overrange or underrange is indicated exclusively by symbols.

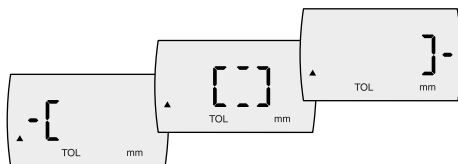

High operating reliability



Lock function prevents unintentional key operation. All keys or individual functions can be locked. If a locked key is pressed, "LOC" appears in the numeric display.

IP protection class IP54 (optional)



- Protective cap at the end of the measuring pin
- Rubber bellows on measuring pin
- Sealed battery compartment

| | | |
|----------------|-----------|---|
| Code Letters | IP | International Protection |
| First numeral | 5 | Dust protection (from harmful dust deposits) |
| Second numeral | 4 | Protection against water splash in all directions |

Universal SPC interface



• Integrated Wireless

Radio interface at the price of a cable



• USB

No interface box necessary! Simple and cost-effective installation of multipoint measuring systems via USB hubs



• Digimatic

For connection to a digimatic compatible evaluation unit



• Mahr Opto RS232C

For direct connection to a COM port on the PC



Absolute-function:



Dial gage can be set to 0.000 in any position without losing reference to the preset value

3-year battery life

The Reference System is particularly energy-efficient. Since almost no energy is required when the system is idle, battery life is increased to 3 years*.

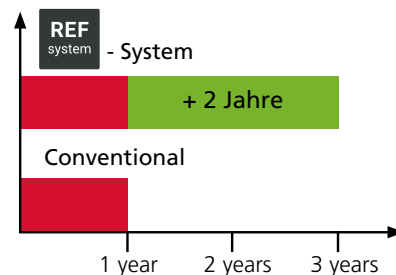

*When wireless transmission is deactivated

One-time zeroing



The digital indicators 1075 R, 1086 R(i) and 1087 R(i) are equipped with the innovative Reference System. Once the zero position has been set, it remains stored for all further measurements. This means that the instrument is immediately ready for measurement after pressing the ON button or simply by moving the measuring bolt. The need to reset the instrument to zero again after switching it on is no longer necessary like it is with conventional dial gages.

MarConnect Integrated Wireless – wireless transmission at the price of a cable



With Integrated Wireless, you get wireless data transmission for the price of a cable. Data acquisition with indicators is now even easier: Transfer your measurement data simply and without annoying cables directly into Microsoft® Office Excel® or via keyboard code into any Windows® program.

MarCator | Terms

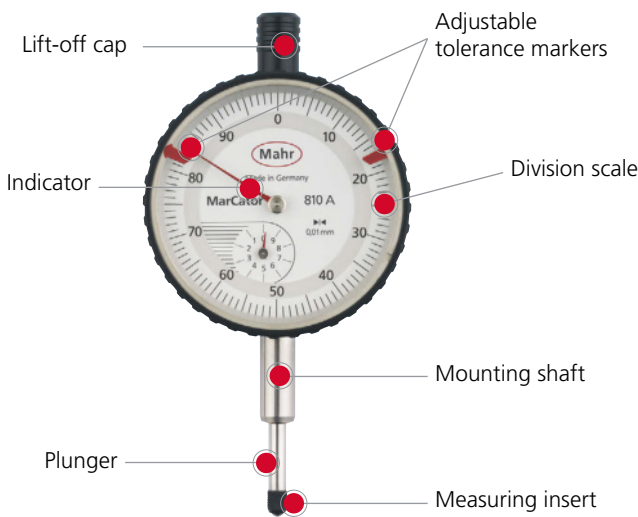

Metrological characteristics

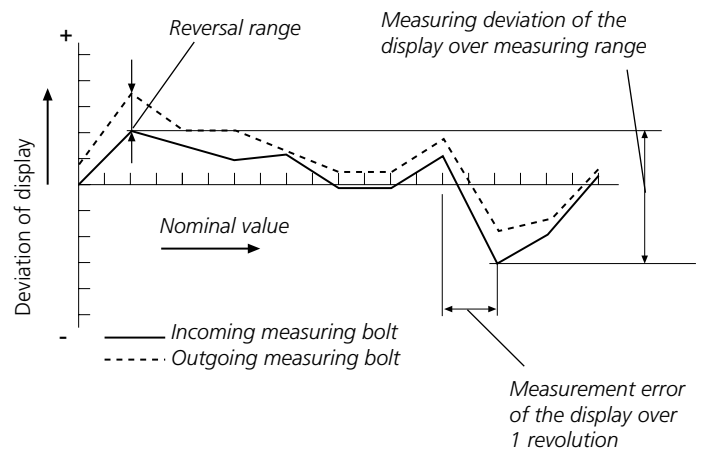

MarCator | Models

Small dial indicator
803 S

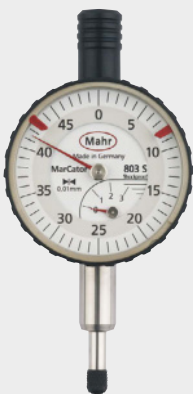

Dial indicator 810 S

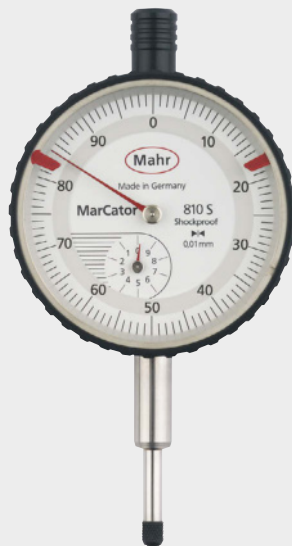

Digital indicator 1075 R



Digital indicator 1087 Ri



MarCator 1075 R

Digital indicator



FUNCTIONS

- ON/OFF
- RESET (set display to zero)
- mm/inch
- Reversal of counting direction
- PRESET (for entering a numerical value)
- DATA (data transmission via connection cable)
- LOCK function (key lock)
- AUTO-ON / OFF



FEATURES

- High contrast LCD display
- Hermetically sealed protective measuring spindle cap
- Mounting shank and measuring spindle are both made of hardened stainless steel
- **Software:** MarCom Professional free download: www.mahr.com/marcom (only for Mahr data cables and wireless systems with USB and RS-232 interface)
- **Digit height:** 12 mm
- **Data interface:** Digimatic, Opto RS-232C, USB
- **Energy supply:** Battery life approx. 3 years
- Battery type: CR 2032 (3V Lithium)
- **IP protection category:** IP 52
- **Package contains:** battery, instruction manual

Application:

- Simple measuring function for static measurements such as lengths, distances and length differences

TECHNICAL DATA

| Order no. | 4336010 | 4336020 | 4336030 | |
|----------------------------------|------------------|---------|---------|---------|
| Type | 1075 R | | | |
| Measuring span | mm | 12.5 | | |
| Measuring span | inch | .5" | | |
| Resolution | mm | 0.01 | 0.005 | 0.001 |
| Resolution | inch | .0005" | .0001" | .00005" |
| Error limit | mm | 0.02 | 0.015 | 0.005 |
| Measuring force | N | 0.5 – 1 | | |
| Standard | Factory standard | | | |
| Protective measuring spindle cap | • | | | |

| Order no. | Mounting shaft |
|-----------|----------------|
| | mm |
| 4336010 | 8 |
| 4336020 | 8 |
| 4336030 | 8 |

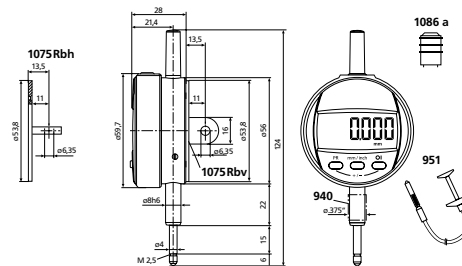

ACCESSORIES

| Order no. | Description | Type |
|-----------|---|----------|
| 4102357 | 16 EXu data connection cable USB (2 m) | 16 EXu |
| 4102915 | Interface adapter with data cable Digimatic (2 m) | 16 EWd |
| 4102410 | Data connection cable RS232C (2 m) | 16 EXr |
| 4310103 | Adapter bushing (.375" / 8 mm) | 940 |
| 4372000 | Cable release (250 mm) | 951 |
| 4375004 | Protective cap for 1075 R / 1086 R / 1087 R | 1086 s |
| 4337320 | Lift-off cap, complete 12.5 / 25 mm | |
| 4336041 | Lug back, horizontal | 1075 Rbh |
| 4336042 | Lug back, vertical | 1075 Rbv |

MarCator 1086 Ri

Digital indicator



FUNCTIONS

- ON/OFF
- RESET (set display to zero)
- mm/inch
- Reversal of counting direction
- PRESET (for entering a numerical value)
- TOL (enter tolerance limit values)
- <0> (tolerance GO / NO GO display mode)
- ABS (display can be set to zero without losing reference to preset)
- DATA (data transmission)
- Factor (adjustable)
- LOCK (individual key lock)

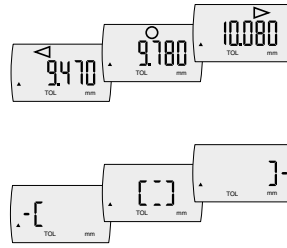

Application:

- Comprehensive measuring function for static measurements such as lengths, distances and length differences

FEATURES

- Integrated wireless transmitter
- High contrast LCD
- Operating and display unit (bezel) can be rotated through 280°
- Mounting shank and measuring spindle are both made of hardened stainless steel
- Immediate measurements due to the Reference System
- **Software:** MarCom Professional free download: www.mahr.com/marcom (only for Mahr data cables and wireless systems with USB and RS-232 interface)
- **Digit height:** 11 mm
- **Data interface:** Integrated wireless, USB, Digimatic, Opto RS-232C
- **Battery type:** CR 2450N (3V Lithium)
- **IP protection category:** IP 42
- **Package contains:** instruction manual, battery

TECHNICAL DATA

| Order no. | | 4337624 | 4337625 | 4337626 | 4337627 | 4337628 |
|---------------------------------|------|--|-------------|------------|-----------|---------|
| Type | | 1086 Ri | | | | |
| Measuring span | mm | 12.5 | 25 | 50 | 100 | 25 |
| Measuring span | inch | .5" | 1" | 2" | 4" | 1" |
| Resolution | mm | 0.0005, 0.001, 0.002, 0.005, 0.01 | | | | |
| Resolution | inch | .00002", .00005", .0001", .0002", .0005" | | | | |
| Error limit | mm | 0.004 | | | | |
| Error limit over 50 graduations | mm | 0.002 | | | | |
| Measuring force | N | 0.65 - 0.9 | 0.65 - 1.15 | 1.25 - 2.7 | 1.8 - 3.5 | 0 - 0 |
| Standard | | Factory standard | | | | |
| Lifting protection cap | | • | | | | |

| Order no. | a | b | c | Mounting shaft |
|-----------|-------|------|------|----------------|
| | mm | mm | mm | mm |
| 4337624 | 126.3 | 23 | 13.5 | 8 |
| 4337625 | 153.4 | 26.8 | 26.5 | 8 |
| 4337626 | 267.3 | 40 | 52 | 8 |
| 4337627 | 420.3 | 91 | 103 | 8 |
| 4337628 | 153.4 | 26.8 | 26.5 | 8 |

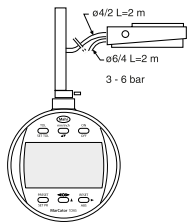
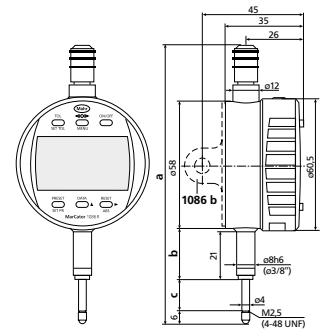

1082 p

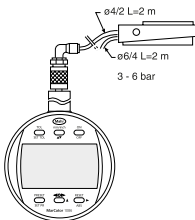

1082 p

ACCESSORIES

| Order no. | Description | Type |
|-----------|---|---------|
| 4102220 | Receiver for instruments with Integrated Wireless | i-Stick |
| 4102357 | 16 EXu data connection cable USB (2 m) | 16 EXu |
| 4102915 | Interface adapter with data cable Digimatic (2 m) | 16 EWD |
| 4102410 | Data connection cable RS232C (2 m) | 16 EXr |
| 4375004 | Protective cap for 1075 R / 1086 R / 1087 R | 1086 s |
| 4337421 | Lug back | 1086 b |
| 4336311 | Cable release (12.5 + 25 mm) | 1085 a |
| 4336237 | Pneumatic lifting (12.5 + 25 mm) | 1082 p |
| 4310103 | Adapter bushing (.375" / 8 mm) | 940 |
| 4336230 | Pneumatic lifting (50 + 100 mm) | 1082 p |

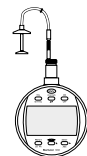

1085 a



i-Stick

MarCator 1086 Ri

Digital indicator



FUNCTIONS

- ON/OFF
- RESET (set display to zero)
- mm/inch
- Reversal of counting direction
- PRESET (for entering a numerical value)
- TOL (enter tolerance limit values)
- <0> (tolerance GO / NO GO display mode)
- ABS (display can be set to zero without losing reference to preset)
- DATA (data transmission)
- Factor (adjustable)
- LOCK (individual key lock)

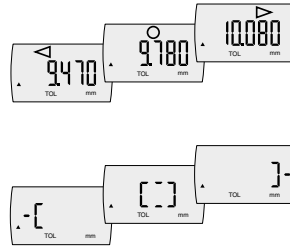

Application:

- Comprehensive measuring function for static measurements such as lengths, distances and length differences

FEATURES

- Integrated Wireless transmitter
- High contrast LCD display
- Operating and display unit (bezel) can be rotated through 280°
- Mounting shank and measuring spindle are both made of hardened stainless steel
- Immediate measurements due to the Reference System
- **Software:** MarCom Professional free download: www.mahr.com/marcom (only for Mahr data cables and wireless systems with USB and RS-232C interface)
- **Digit height:** 11 mm
- **Data interface:** Integrated Wireless, USB, Digimatic, Opto RS-232C
- **Battery type:** CR 2450N (3V Lithium)
- **IP protection category:** IP 42
- **Package contains:** instruction manual, battery

TECHNICAL DATA

| Order no. | 4337134 | 4337135 |
|---------------------------------|------------------|------------|
| Type | 1086 Ri | |
| Measuring span | mm | 12.5 |
| Measuring span | inch | .5" |
| Resolution | mm | 0.01 |
| Resolution | inch | .0005" |
| Error limit | mm | 0.02 |
| Error limit over 50 graduations | mm | 0.02 |
| Measuring force | N | 0.65 – 0.9 |
| Standard | Factory standard | |
| Lifting protection cap | • | |

| Order no. | a | b | c | Mounting shaft |
|-----------|-------|------|------|----------------|
| | mm | mm | mm | mm |
| 4337134 | 126.3 | 23 | 13.5 | 8 |
| 4337135 | 153.4 | 26.8 | 26.5 | 8 |

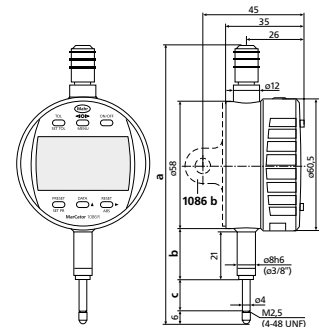

ACCESSORIES

| Order no. | Description | Type |
|-----------|---|---------|
| 4102220 | Receiver for instruments with Integrated Wireless | i-Stick |
| 4102357 | 16 EXu data connection cable USB (2 m) | 16 EXu |
| 4102915 | Interface adapter with data cable Digimatic (2 m) | 16 EWd |
| 4102410 | Data connection cable RS232C (2 m) | 16 EXr |
| 4375004 | Protective cap for 1075 R / 1086 R / 1087 R | 1086 s |
| 4337421 | Lug back | 1086 b |
| 4310103 | Adapter bushing (.375" / 8 mm) | 940 |
| 4336311 | Cable release (12.5 + 25 mm) | 1085 a |
| 4336237 | Pneumatic lifting (12.5 + 25 mm) | 1082 p |

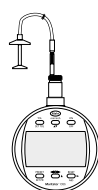

1085 a

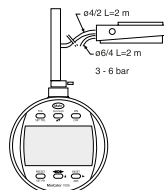

1082 p



i-Stick

MarCator 1086 WRi

Digital indicator



FUNCTIONS

- ON/OFF
- RESET (set display to zero)
- mm/inch
- Reversal of counting direction
- PRESET (for entering a numerical value)
- TOL (enter tolerance limit values)
- <0> (tolerance GO / NO GO display mode)
- ABS (display can be set to zero without losing reference to preset)
- DATA (data transmission)
- Factor (adjustable)
- LOCK (individual key lock)

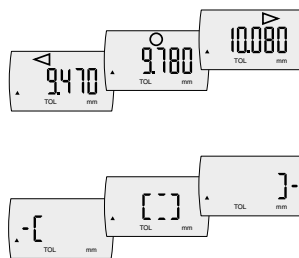

Application:

- Comprehensive measuring function for static measurements such as lengths, distances and length differences

FEATURES

- Integrated Wireless transmitter
- High contrast LCD display
- Operating and display unit (bezel) can be rotated through 280°
- Mounting shank and measuring spindle are both made of hardened stainless steel
- Immediate measurements due to the Reference System
- **Software:** MarCom Professional free download: www.mahr.com/marcom (only for Mahr data cables and wireless systems with USB and RS-232 interface)
- **Digit height:** 11 mm
- **Data interface:** Integrated Wireless, USB, Digimatic, Opto RS-232C
- **Battery type:** CR 2450N (3V Lithium)
- **IP protection category:** IP 54
- **Package contains:** instruction manual, battery

TECHNICAL DATA

| Order no. | 4337142 | 4337143 |
|----------------------------------|------------------|--|
| Type | 1086 WRi | |
| Measuring span | mm | 12.5 |
| Measuring span | inch | .5" |
| Resolution | mm | 0.0005, 0.001, 0.002, 0.005, 0.01 |
| Resolution | inch | .00002", .00005", .0001", .0002", .0005" |
| Error limit | mm | 0.004 |
| Error limit over 50 graduations | mm | 0.002 |
| Measuring force | N | 0.65 – 1.4 |
| Standard | Factory standard | |
| Protective measuring spindle cap | • | |

| Order no. | a | b | c | Mounting shaft |
|-----------|-------|------|------|----------------|
| | mm | mm | mm | mm |
| 4337142 | 144.3 | 21 | 28.5 | 8 |
| 4337143 | 193.2 | 24.8 | 50 | 8 |

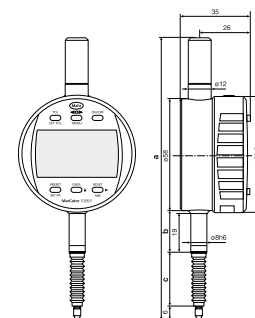

ACCESSORIES

| Order no. | Description | Type |
|-----------|---|---------|
| 4102220 | Receiver for instruments with Integrated Wireless | i-Stick |
| 4102357 | 16 EXu data connection cable USB (2 m) | 16 EXu |
| 4102915 | Interface adapter with data cable Digimatic (2 m) | 16 EWd |
| 4102410 | Data connection cable RS232C (2 m) | 16 EXr |
| 4375004 | Protective cap for 1075 R / 1086 R / 1087 R | 1086 s |
| 4337421 | Lug back | 1086 b |
| 4336311 | Cable release (12.5 + 25 mm) | 1085 a |
| 4310103 | Adapter bushing (.375" / 8 mm) | 940 |
| 4336237 | Pneumatic lifting (12.5 + 25 mm) | 1082 p |
| 4337472-E | Rubber bellows (12.5 mm) | |
| 4337474-E | Rubber bellows (25 mm) | |

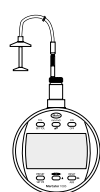

1085 a

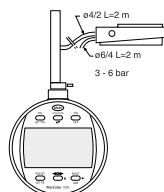

1082 p



i-Stick

MarCator 1086 R / 1086 ZR

Digital indicator



FUNCTIONS

- ON/OFF
- RESET (set display to zero)
- mm/inch
- Reversal of counting direction
- PRESET (for entering a numerical value)
- TOL (enter tolerance limit values)
- <0> (tolerance GO / NO GO display mode)
- ABS (display can be set to zero without losing reference to preset)
- DATA (data transmission via connection cable)
- Factor (adjustable)
- LOCK (individual key lock)

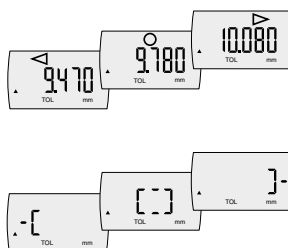

Application:

- Comprehensive measuring function for static measurements such as lengths, distances and length differences

FEATURES

- High contrast LCD display
- Operating and display unit (bezel) can be rotated through 280°
- Lifter protection cap on the measuring spindle
- Mounting shank and measuring spindle are both made of hardened stainless steel
- Immediate measurements due to the Reference System
- **Software:** MarCom Professional free download: www.mahr.com/marcom (only for Mahr data cables and wireless systems with USB and RS-232 interface)
- **Digit height:** 11 mm
- **Data interface:** Digimatic, Opto RS-232C, USB
- **Energy supply:** Battery life approx. 3 years
- **Battery type:** CR 2450N (3V Lithium)
- **IP protection category:** IP 42
- **Package contains:** instruction manual, battery

TECHNICAL DATA

| Order no. | 4337620 | 4337621 | 4337622 | 4337623 | 4337650 | 4337651 |
|---------------------------------|------------------|--|-------------|------------|-----------|-----------------------|
| Type | 1086 R | | | 1086 ZR | | |
| Measuring span | mm | 12.5 | 25 | 50 | 100 | 12.5 25 |
| Measuring span | inch | .5" | 1" | 2" | 4" | .5" 1" |
| Resolution | mm | 0.0005, 0.001, 0.002, 0.005, 0.01 | | | | |
| Resolution | inch | .00002", .00005", .0001", .0002", .0005" | | | | |
| Error limit | mm | 0.004 | 0.007 | 0.008 | 0.004 | |
| Error limit over 50 graduations | mm | 0.002 | | | | |
| Measuring force | N | 0.65 - 0.9 | 0.65 - 1.15 | 1.25 - 2.7 | 1.8 - 3.5 | 0.65 - 0.9 0.9 - 1.15 |
| Standard | Factory standard | | | | | |

| Order no. | a | b | c | Mounting shaft | Mounting shaft |
|-----------|-------|------|------|----------------|----------------|
| | mm | mm | mm | inch | mm |
| 4337620 | 126.3 | 23 | 13.5 | | 8 |
| 4337621 | 153.4 | 26.8 | 26.5 | | 8 |
| 4337622 | 267.3 | 40 | 52 | | 8 |
| 4337623 | 420.3 | 91 | 103 | | 8 |
| 4337650 | 126.3 | 23 | 13.5 | 0.375 | |
| 4337651 | 153.4 | 26.8 | 26.5 | 0.375 | |

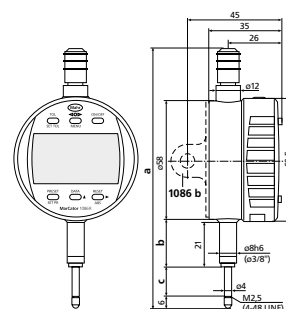

ACCESSORIES

| Order no. | Description | Type |
|-----------|---|--------|
| 4102357 | 16 EXu data connection cable USB (2 m) | 16 EXu |
| 4102915 | Interface adapter with data cable digimatic (2 m) | 16 EWd |
| 4102410 | Data connection cable RS232C (2 m) | 16 EXr |
| 4375004 | Protective cap for 1075 R / 1086 R / 1087 R | 1086 s |
| 4337421 | Lug back | 1086 b |
| 4336311 | Cable release (12.5 + 25 mm) | 1085 a |
| 4336237 | Pneumatic lifting (12.5 + 25 mm) | 1082 p |
| 4310103 | Adapter bushing (.375" / 8 mm) | 940 |
| 4336230 | Pneumatic lifting (50 + 100 mm) | 1082 p |

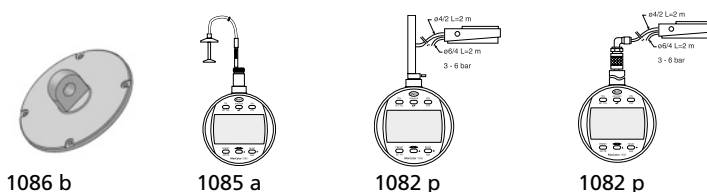

MarCator 1086 R

Digital indicator



FUNCTIONS

- ON/OFF
- RESET (set display to zero)
- mm/inch
- Reversal of counting direction
- PRESET (for entering a numerical value)
- TOL (enter tolerance limit values)
- <0> (tolerance GO / NO GO display mode)
- ABS (display can be set to zero without losing reference to preset)
- DATA (data transmission via connection cable)
- Factor (adjustable)
- LOCK (individual key lock)

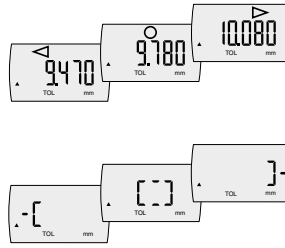

Application:

- Comprehensive measuring function for static measurements such as lengths, distances and length differences

FEATURES

- High contrast LCD display
- Operating and display unit (bezel) can be rotated through 280°
- Lifter protection cap on the measuring spindle
- Mounting shank and measuring spindle are both made of hardened stainless steel
- Immediate measurements due to the Reference System
- **Software:** MarCom Professional free download: www.mahr.com/marcom (only for Mahr data cables and wireless systems with USB and RS-232 interface)
- **Digit height:** 11 mm
- **Data interface:** Digimatic, Opto RS-232C, USB
- **Energy supply:** Battery life approx. 3 years
- **Battery type:** CR 2450N (3V Lithium)
- **IP protection category:** IP 24
- **Package contains:** instruction manual, battery

TECHNICAL DATA

| Order no. | 4337130 | 4337131 | 4337132 | 4337133 | |
|---------------------------------|------------------|------------|-------------|------------|-----------|
| Type | 1086 R | | | | |
| Measuring span | mm | 12.5 | 25 | 50 | 100 |
| Measuring span | inch | .5" | 1" | 2" | 4" |
| Resolution | mm | 0.01 | | | |
| Resolution | inch | .0005" | | | |
| Error limit | mm | 0.02 | | | |
| Error limit over 50 graduations | mm | 0.02 | | | |
| Measuring force | N | 0.65 – 0.9 | 0.65 – 1.15 | 1.25 – 2.7 | 1.6 – 3.5 |
| Standard | Factory standard | | | | |
| Lifting protection cap | • | | | | |

| Order no. | a | b | c | Mounting shaft |
|-----------|-------|------|------|----------------|
| | mm | mm | mm | mm |
| 4337130 | 126.3 | 23 | 13.5 | 8 |
| 4337131 | 153.4 | 26.8 | 26.5 | 8 |
| 4337132 | 267.3 | 40 | 52 | 8 |
| 4337133 | 420.3 | 91 | 103 | 8 |

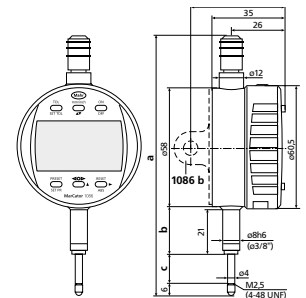

ACCESSORIES

| Order no. | Description | Type |
|-----------|---|--------|
| 4102357 | 16 EXu data connection cable USB (2 m) | 16 EXu |
| 4102915 | Interface adapter with data cable Digimatic (2 m) | 16 EWD |
| 4102410 | Data connection cable RS232C (2 m) | 16 EXr |
| 4375004 | Protective cap for 1075 R / 1086 R / 1087 R | 1086 s |
| 4337421 | Lug back | 1086 b |
| 4336311 | Cable release (12.5 + 25 mm) | 1085 a |
| 4336237 | Pneumatic lifting (12.5 + 25 mm) | 1082 p |
| 4310103 | Adapter bushing (.375" / 8 mm) | 940 |
| 4336230 | Pneumatic lifting (50 + 100 mm) | 1082 p |

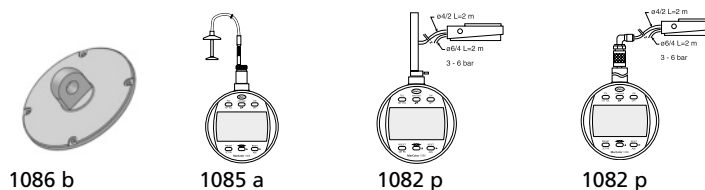

MarCator 1086 WR

Digital indicator



FUNCTIONS

- ON/OFF
- RESET (set display to zero)
- mm/inch
- Reversal of counting direction
- PRESET (for entering a numerical value)
- TOL (enter tolerance limit values)
- <0> (tolerance GO / NO GO display mode)
- ABS (display can be set to zero without losing reference to preset)
- DATA (data transmission via connection cable)
- Factor (adjustable)
- LOCK (individual key lock)

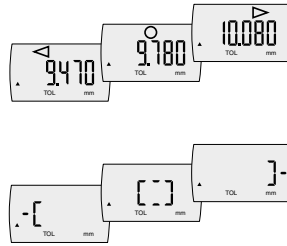

Application:

- Comprehensive measuring function for static measurements such as lengths, distances and length differences

FEATURES

- High contrast LCD display
- Operating and display unit (bezel) can be rotated through 280°
- Protection cap on the end of measuring spindle
- Mounting shank and measuring spindle are both made of hardened stainless steel
- Immediate measurements due to the Reference System
- **Software:** MarCom Professional free download: www.mahr.com/marcom (only for Mahr data cables and wireless systems with USB and RS-232 interface)
- **Digit height:** 11 mm
- **Data interface:** Digimatic, Opto RS-232C, USB
- **Energy supply:** Battery life approx. 3 years
- **Battery type:** CR 2450N (3V Lithium)
- **IP protection category:** IP 54
- **Package contains:** instruction manual, battery

TECHNICAL DATA

| Order no. | 4337640 | 4337641 |
|----------------------------------|---|----------|
| Type | 1086 WR | |
| Measuring span | mm 12.5 | 25 |
| Measuring span | inch .5" | 1" |
| Resolution | mm 0.0005, 0.001, 0.002, 0.005, 0.01 | |
| Resolution | inch .00002", .00005", .0001", .0002", .0005" | |
| Error limit | mm 0.004 | |
| Error limit over 50 graduations | mm 0.002 | |
| Measuring force | N 0.65 – 1.4 | 1 – 2.25 |
| Standard | Factory standard | |
| Protective measuring spindle cap | • | |

| Order no. | a | b | c | Mounting shaft |
|-----------|-------|------|------|----------------|
| | mm | mm | mm | mm |
| 4337640 | 144.3 | 21 | 28.5 | 8 |
| 4337641 | 193.2 | 24.8 | 50 | 8 |

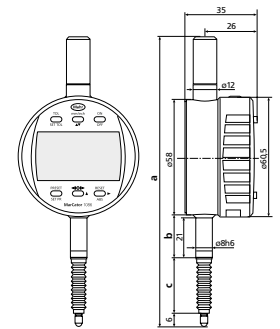

ACCESSORIES

| Order no. | Description | Type |
|-----------|---|--------|
| 4102357 | 16 EXu data connection cable USB (2 m) | 16 EXu |
| 4102915 | Interface adapter with data cable Digimatic (2 m) | 16 EWd |
| 4102410 | Data connection cable RS232C (2 m) | 16 EXr |
| 4375004 | Protective cap for 1075 R / 1086 R / 1087 R | 1086 s |
| 4337421 | Lug back | 1086 b |
| 4336311 | Cable release (12.5 + 25 mm) | 1085 a |
| 4336237 | Pneumatic lifting (12.5 + 25 mm) | 1082 p |
| 4337472-E | Rubber bellows (12.5 mm) | |
| 4310103 | Adapter bushing (.375" / 8 mm) | 940 |
| 4884464 | Battery 3 V, CR 2450, Type CR 2450 | |
| 4337474-E | Rubber bellows (25 mm) | |

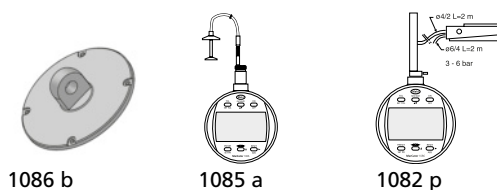

MarCator 1086 R-HR

Digital indicator



FUNCTIONS

- ON/OFF
- RESET (set display to zero)
- mm/inch
- Reversal of counting direction
- PRESET (for entering a numerical value)
- TOL (enter tolerance limit values)
- <0> (tolerance GO / NO GO display mode)
- ABS (display can be set to zero without losing reference to preset)
- DATA (data transmission via connection cable)
- Factor (adjustable)
- LOCK (individual key lock)



Applications:

- High-resolution measuring system with 0.1 μm resolution
- Extensive measuring functions for static measurements e.g. lengths, distances and length differences

FEATURES

- High contrast LCD display
- Operating and display unit (bezel) can be rotated through 280°
- Lifter protection cap on the measuring spindle
- Mounting shank and measuring spindle are both made of hardened stainless steel
- Immediate measurements due to the Reference System
- **Software:** MarCom Professional free download: www.mahr.com/marcom (only for Mahr data cables and wireless systems with USB and RS-232 interface)
- **Digit height:** 11 mm
- **Data interface:** Digimatic, Opto RS-232C, USB
- **Energy supply:** Battery life approx. 3 years
- **Battery type:** CR 2450N (3V Lithium)
- **IP protection category:** IP 42
- **Package contains:** instruction manual, battery

TECHNICAL DATA

| Order no. | 4337697 | | 4337698 | |
|---------------------------------|------------------|---|-------------|--|
| Type | 1086 R-HR | | | |
| Measuring span | mm | 12.5 | 25 | |
| Measuring span | inch | .5" | 1" | |
| Resolution | mm | 0.0001, 0.0005, 0.001, 0.002, 0.005, 0.01 | | |
| Resolution | inch | .00001", .00002", .00005", .0001", .0002", .0005" | | |
| Error limit | mm | 0.0018 | 0.0024 | |
| Error limit over 50 graduations | mm | 0.0005 | | |
| Measuring force | N | 0.65 – 0.9 | 0.65 – 1.15 | |
| Standard | Factory standard | | | |
| Lifting protection cap | • | | | |

| Order no. | a | b | c | Mounting shaft |
|-----------|-------|------|------|----------------|
| | mm | mm | mm | mm |
| 4337697 | 126.3 | 23 | 13.5 | 8 |
| 4337698 | 153.4 | 26.8 | 26.5 | 8 |

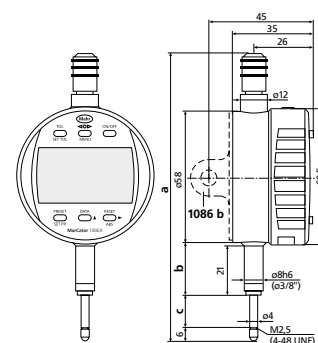

ACCESSORIES

| Order no. | Description | Type |
|-----------|---|--------|
| 4102357 | 16 EXu data connection cable USB (2 m) | 16 EXu |
| 4102915 | Interface adapter with data cable Digimatic (2 m) | 16 EWd |
| 4102410 | Data connection cable RS232C (2 m) | 16 EXr |
| 4375004 | Protective cap for 1075 R / 1086 R / 1087 R | 1086 s |
| 4337421 | Lug back | 1086 b |
| 4336311 | Cable release (12.5 + 25 mm) | 1085 a |
| 4336237 | Pneumatic lifting (12.5 + 25 mm) | 1082 p |
| 4310103 | Adapter bushing (.375" / 8 mm) | 940 |

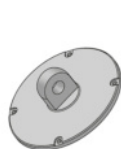

1086 b

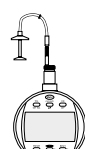

1085 a

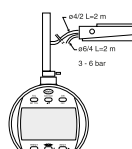

1082 p

MarCator 1087 Ri

Digital indicator



FUNCTIONS

- 0 (set the analog scale display to zero)
- ABS (display can be set to zero without losing reference to preset)
- AUTO-ON / OFF
- DATA (data transmission)
- Factor (adjustable)
- LOCK (individual key lock)
- MAX/MIN memory for searching the reversal point
- ON/OFF
- PRESET (for entering a numerical value)
- RANGE (switch the measuring range and resolution)
- RESET (set display to zero)
- (MAX-MIN) for testing flatness and concentricity
- TOL (enter tolerance limit values)
- Reversal of counting direction
- mm/inch



Applications:

Comprehensive measuring functions for

- Static measurements such as lengths, distances and length differences
- Dynamic measurements such as radial runout, straightness and flatness via MAX / MIN / MAX-MIN functions

FEATURES

- Integrated Wireless transmitter
- High contrast LCD display
- Operating and display unit (bezel) can be rotated through 280°
- Lifter protection cap on the measuring spindle
- Clamping shaft and measuring pin made of hardened stainless steel
- Immediate measurements due to the Reference System
- **Software:** MarCom Professional free download: www.mahr.com/marcom (only for Mahr data cables and wireless systems with USB and RS-232 interface)
- **Digit height:** 8,5 mm
- **Data interface:** Integrated Wireless, USB, Digimatic, Opto RS-232C
- **Energy supply:** battery operation
- **Battery type:** CR 2450N (3V Lithium)
- **IP protection category:** IP 42
- **Package contains:** instruction manual, battery

TECHNICAL DATA

| Order no. | 4337663 | 4337665 | 4337667 |
|---------------------------------|------------------|---|------------|
| Type | 1087 Ri | | |
| Measuring span | mm | 12.5 | 25 |
| Measuring span | inch | .5" | 1" |
| Resolution | mm | 0.0005, 0.001, 0.002, 0.005, 0.01 | |
| Resolution | inch | .00002", .00005", .0001", .0002", .0005" | |
| Scale graduation values | mm | 0.0005, 0.001, 0.002, 0.005, 0.01 | |
| Graduation values | inch | .000002", .00005", .0001", .0002", .0005" | |
| Range of analog display | mm | ± 0.01, ± 0.02, ± 0.04, ± 0.1, ± 0.2 | |
| Range of analog display | inch | ± .0004", ± .001", ± .002", ± .004", ± .01" | |
| Error limit | mm | 0.004 | |
| Error limit over 50 graduations | mm | 0.002 | |
| Measuring force | N | 0.65 – 0.85 | 0.65 – 0.9 |
| Standard | Factory standard | | |
| Lifting protection cap | • | | |

| Order no. | a | b | c | Mounting shaft |
|-----------|-------|------|------|----------------|
| | mm | mm | mm | mm |
| 4337663 | 126.3 | 23 | 13.5 | 8 |
| 4337665 | 153.4 | 26.8 | 26.5 | 8 |
| 4337667 | 267.3 | 40 | 52 | 8 |

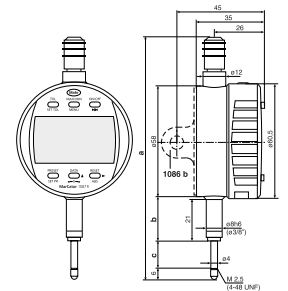

ACCESSORIES

| Order no. | Description | Type |
|-----------|---|---------|
| 4102220 | Receiver for instruments with Integrated Wireless | i-Stick |
| 4102357 | 16 EXu data connection cable USB (2 m) | 16 EXu |
| 4102915 | Interface adapter with data cable Digimatic (2 m) | 16 EWd |
| 4102410 | Data connection cable RS232C (2 m) | 16 EXr |
| 4375004 | Protective cap for 1075 R / 1086 R / 1087 R | 1086 s |
| 4337421 | Lug back | 1086 b |
| 4336237 | Pneumatic lifting (12.5 + 25 mm) | 1082 p |
| 4336311 | Cable release (12.5 + 25 mm) | 1085 a |
| 4310103 | Adapter bushing (.375" / 8 mm) | 940 |
| 4336230 | Pneumatic lifting (50 + 100 mm) | 1082 p |

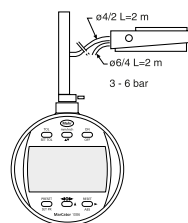

1082 p

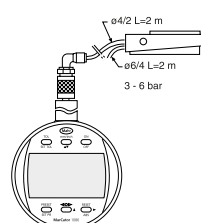

1082 p

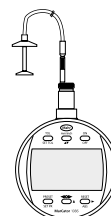

1085 a



i-Stick



1086 b

MarCator 1087 R / 1087 ZR

Digital indicator



FUNCTIONS

- ON/OFF
- RESET (set display to zero)
- mm/inch
- Reversal of counting direction
- PRESET (for entering a numerical value)
- TOL (enter tolerance limit values)
- MAX/MIN memory for searching the reversal point
- (MAX-MIN) for testing flatness and concentricity
- ABS (display can be set to zero without losing reference to preset)
- DATA (data transmission via connection cable)
- Factor (adjustable)
- LOCK (individual key lock)



Applications:

Comprehensive measuring functions for

- Static measurements such as lengths, distances and length differences
- Dynamic measurements such as radial runout, straightness and flatness via MAX / MIN / MAX-MIN functions

FEATURES

- High contrast LCD display, thus very clear and safe to read
- Operating and display unit (bezel) can be rotated through 280°
- Immediate measurements due to the Reference System
- Lifter protection cap on the measuring spindle
- Mounting shank and measuring spindle are both made of hardened stainless steel
- **Software:** MarCom Professional free download: www.mahr.com/marcom (only for Mahr data cables and wireless systems with USB and RS-232 interface)
- **Digit height:** 8,5 mm
- **Data interface:** Opto RS-232C, Digimatic, USB
- **Energy supply:** Battery life approx. 3 years
- **Battery type:** CR 2450N (3V Lithium)
- **IP protection category:** IP 42
- **Package contains:** instruction manual, battery

TECHNICAL DATA

| Order no. | 4337660 | 4337661 | 4337666 | 4337670 | 4337671 | |
|---------------------------------|------------------|---|-------------|------------|------------|-------------|
| Type | 1087 R | | 1087 ZR | | | |
| Measuring span | mm | 12.5 | 25 | 50 | 12.5 | 25 |
| Measuring span | inch | .5" | 1" | 2" | .5" | 1" |
| Resolution | mm | 0.0005, 0.001, 0.002, 0.005, 0.01 | | | | |
| Resolution | inch | .00002", .00005", .0001", .0002", .0005" | | | | |
| Scale graduation values | mm | 0.0005, 0.001, 0.002, 0.005, 0.01 | | | | |
| Graduation values | inch | .000002", .00005", .0001", .0002", .0005" | | | | |
| Range of analog display | mm | ± 0.01, ± 0.02, ± 0.04, ± 0.1, ± 0.2 | | | | |
| Range of analog display | inch | ± .0004", ± .001", ± .002", ± .004", ± .01" | | | | |
| Error limit | mm | 0.004 | | 0.007 | | 0.004 |
| Error limit over 50 graduations | mm | 0.002 | | | | |
| Measuring force | N | 0.65 – 0.9 | 0.65 – 1.15 | 1.25 – 2.7 | 0.65 – 0.9 | 0.65 – 1.15 |
| Standard | Factory standard | | | | | |
| Lifting protection cap | • | | | | | |

| Order no. | a | b | c | Mounting shaft | Mounting shaft |
|-----------|-------|------|------|----------------|----------------|
| | mm | mm | mm | inch | mm |
| 4337660 | 126.3 | 23 | 13.5 | | 8 |
| 4337661 | 153.4 | 26.8 | 26.5 | | 8 |
| 4337666 | 267.3 | 40 | 52 | | 8 |
| 4337670 | 126.3 | 23 | 13.5 | 0.375 | |
| 4337671 | 153.4 | 26.8 | 26.5 | 0.375 | |

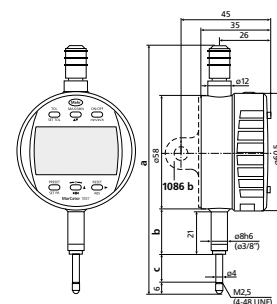

ACCESSORIES

| Order no. | Description | Type |
|-----------|---|--------|
| 4102357 | 16 EXu Data connection cable USB (2 m) | 16 EXu |
| 4102915 | Interface adapter with data cable Digimatic (2 m) | 16 EWd |
| 4102410 | Data connection cable RS232C (2 m) | 16 EXr |
| 4375004 | Protective cap for 1075 R / 1086 R / 1087 R | 1086 s |
| 4337421 | Lug back | 1086 b |
| 4336237 | Pneumatic lifting (12.5 + 25 mm) | 1082 p |
| 4336311 | Cable release (12.5 + 25 mm) | 1085 a |
| 4310103 | Adapter bushing (.375" / 8 mm) | 940 |
| 4336230 | Pneumatic lifting (50 + 100 mm) | 1082 p |

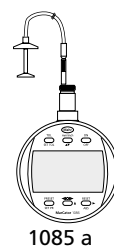
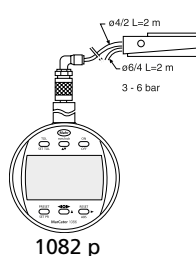
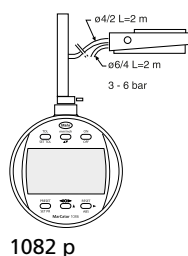

MarCator 1087 R-HR

Digital indicator



FUNCTIONS

- ON/OFF
- RESET (set display to zero)
- mm/inch
- Reversal of counting direction
- PRESET (for entering a numerical value)
- TOL (enter tolerance limit values)
- MAX/MIN memory for searching the reversal point
- (MAX-MIN) for testing flatness and concentricity
- ABS (display can be set to zero without losing reference to preset)
- DATA (data transmission via connection cable)
- Factor (adjustable)
- LOCK (individual key lock)



Applications:

High-resolution model: Resolution 0.1 μm

- Extensive measuring functions for:
 - Static measurements e.g. lengths, distances and length differences
 - Dynamic measurements e.g. radial runout, straightness and flatness, by means of MAX / MIN / MAX-MIN functions

FEATURES

- High contrast LCD display
- Operating and display unit (bezel) can be rotated through 280°
- Immediate measurements due to the Reference System
- Lifter protection cap on the measuring spindle
- Mounting shank and measuring spindle are both made of hardened stainless steel
- **Software:** MarCom Professional free download: www.mahr.com/marcom (only for Mahr data cables and wireless systems with USB and RS-232 interface)
- **Digit height:** 8,5 mm
- **Data interface:** Opto RS-232C, Digimatic, USB
- **Energy supply:** Battery life approx. 3 years
- **Battery type:** CR 2450N (3V Lithium)
- **IP protection category:** IP 42
- **Package contains:** instruction manual, battery

TECHNICAL DATA

| Order no. | 4337695 | 4337696 |
|---------------------------------|--|-------------|
| Type | 1087 R-HR | |
| Measuring span | mm 12.5 | 25 |
| Measuring span | inch .5" | 1" |
| Resolution | mm 0.0001, 0.0005, 0.001, 0.002, 0.005, 0.01 | |
| Resolution | inch .00001", .00002", .00005", .0001", .0002", .0005" | |
| Range of analog display | mm ± 0.002, ± 0.01, ± 0.02, ± 0.04, ± 0.1, ± 0.2 | |
| Range of analog display | inch ± .0002", ± .0004", ± .001", ± .002", ± .004", ± .01" | |
| Error limit | mm 0.0018 | 0.0024 |
| Error limit over 50 graduations | mm 0.0005 | |
| Measuring force | N 0.65 – 0.9 | 0.65 – 1.15 |
| Standard | Factory standard | |
| Lifting protection cap | • | |

| Order no. | a | b | c | Mounting shaft |
|-----------|-------|------|------|----------------|
| | mm | mm | mm | mm |
| 4337695 | 126.3 | 23 | 13.5 | 8 |
| 4337696 | 153.4 | 26.8 | 26.5 | 8 |

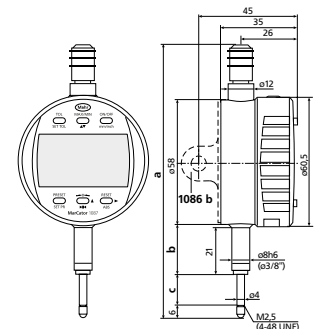

ACCESSORIES

| Order no. | Description | Type |
|-----------|---|--------|
| 4102357 | 16 EXu data connection cable USB (2 m) | 16 EXu |
| 4102915 | Interface adapter with data cable Digimatic (2 m) | 16 EWd |
| 4102410 | Data connection cable RS232C (2 m) | 16 EXr |
| 4375004 | Protective cap for 1075 R / 1086 R / 1087 R | 1086 s |
| 4337421 | Lug back | 1086 b |
| 4336311 | Cable release (12.5 + 25 mm) | 1085 a |
| 4336237 | Pneumatic lifting (12.5 + 25 mm) | 1082 p |
| 4310103 | Adapter bushing (.375" / 8 mm) | 940 |

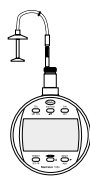

1085 a

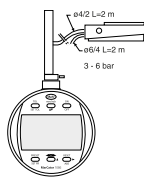

1082 p

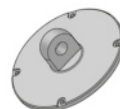

1086 b

MarCator 1087 BRi

Digital indicator



FUNCTIONS

- ON/OFF
- RESET (set display to zero)
- mm/inch
- PRESET (for entering a numerical value)
- Reversal of counting direction
- TOL (enter tolerance limit values)
- START/STOP search for reversal point
- MAX/MIN memory for searching the reversal point
- ABS (display can be set to zero without losing reference to preset)
- 0 (set the analog scale display to zero)
- DATA (data transmission)
- Factor (adjustable)
- LOCK (individual key lock)

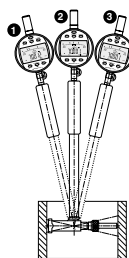

Applications:

- In measurements with a 2-point bore gage the reversing point can be calculated automatically during oscillation. Then a PRESET value can be assigned.
- The ACTUAL value measured is saved by the MIN or MAX function and is shown on the display.
- The 1087 BRi model can process 64 measured values per second, for fast measuring movements combined with measuring certainty.

FEATURES

- Integrated wireless transmitter
- High contrast LCD display
- Operating and display unit (bezel) can be rotated through 280°
- Lifter protection cap on the measuring spindle
- Clamping shaft and measuring pin made of hardened stainless steel
- Immediate measurements due to the Reference System
- **Software:** MarCom Professional free download: www.mahr.com/marcom (only for Mahr data cables and wireless systems with USB and RS-232 interface)
- **Digit height:** 8,5 mm
- **Data interface:** Integrated Wireless, USB, Digimatic, Opto RS-232C
- **Energy supply:** Battery life approx. 3 years
- **Battery type:** CR 2450N (3V Lithium)
- **IP protection category:** IP 42
- **Package contains:** instruction manual, battery

TECHNICAL DATA

| Order no. | 4337664 | | |
|----------------------------------|------------------|---|--|
| Type | 1087 BRi | | |
| Measuring span | mm | 12.5 | |
| Measuring span | inch | .5" | |
| Resolution | mm | 0.0005, 0.001, 0.002, 0.005, 0.01 | |
| Resolution | inch | .00002", .00005", .0001", .0002", .0005" | |
| Scale graduation values | mm | 0.0005, 0.001, 0.002, 0.005, 0.01 | |
| Graduation values | inch | .000002", .00005", .0001", .0002", .0005" | |
| Range of analog display | mm | ± 0.01, ± 0.02, ± 0.04, ± 0.1, ± 0.2 | |
| Range of analog display | inch | ± .0004", ± .001", ± .002", ± .004", ± .01" | |
| Error limit | mm | 0.004 | |
| Error limit over 50 graduations | mm | 0.002 | |
| Measuring force | N | 0.65 – 0.9 | |
| Standard | Factory standard | | |
| Protective measuring spindle cap | • | | |

| Order no. | a | b | c | Mounting shaft |
|-----------|-------|----|------|----------------|
| | mm | mm | mm | mm |
| 4337664 | 126.3 | 23 | 13.5 | 8 |

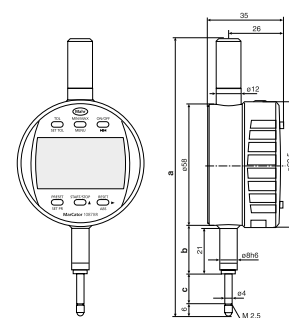

ACCESSORIES

| Order no. | Description | Type |
|-----------|---|---------|
| 4102220 | Receiver for instruments with Integrated Wireless | i-Stick |
| 4102357 | 16 EXu data connection cable USB (2 m) | 16 EXu |
| 4102915 | Interface adapter with data cable Digimatic (2 m) | 16 EWd |
| 4102410 | Data connection cable RS232C (2 m) | 16 EXr |
| 4375004 | Protective cap for 1075 R / 1086 R / 1087 R | 1086 s |
| 4310103 | Adapter bushing (.375" / 8 mm) | 940 |



i-Stick

MarCator 1087 BR

Digital indicator



FUNCTIONS

- ON/OFF
- RESET (set display to zero)
- mm/inch
- PRESET (for entering a numerical value)
- Reversal of counting direction
- TOL (enter tolerance limit values)
- START/STOP search for reversal point
- MAX/MIN memory for searching the reversal point
- ABS (display can be set to zero without losing reference to preset)
- 0 (set the analog scale display to zero)
- DATA (data transmission via connection cable)
- Factor (adjustable)

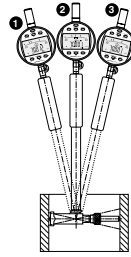

Applications:

- In measurements with a 2-point bore gage the reversing point can be calculated automatically during oscillation. Then a PRESET value can be assigned.
- The ACTUAL value measured is saved by the MIN or MAX function and is shown on the display.
- The 1087 BR model can process 64 measured values per second, for fast measuring movements combined with measuring certainty.

FEATURES

- High contrast LCD display
- Operating and display unit (bezel) can be rotated through 280°
- Immediate measurements due to the Reference System
- Mounting shank and measuring spindle are both made of hardened stainless steel
- Protection cap on the end of measuring spindle
- **Software:** MarCom Professional free download: www.mahr.com/marcom (only for Mahr data cables and wireless systems with USB and RS-232 interface)
- **Digit height:** 8,5 mm
- **Data interface:** Opto RS-232C, Digimatic, USB
- **Energy supply:** Battery life approx. 3 years
- **Battery type:** CR 2450N (3V Lithium)
- **IP protection category:** IP 42
- **Package contains:** instruction manual, battery

TECHNICAL DATA

| Order no. | 4337662 | | |
|----------------------------------|------------------|---|--|
| Type | 1087 BR | | |
| Measuring span | mm | 12.5 | |
| Measuring span | inch | .5" | |
| Resolution | mm | 0.0005, 0.001, 0.002, 0.005, 0.01 | |
| Resolution | inch | .00002", .00005", .0001", .0002", .0005" | |
| Scale graduation values | mm | 0.0005, 0.001, 0.002, 0.005, 0.01 | |
| Graduation values | inch | .000002", .000005", .0001", .0002", .0005" | |
| Range of analog display | mm | ± 0.01, ± 0.02, ± 0.04, ± 0.1, ± 0.2 | |
| Range of analog display | inch | ± .0004", ± .001", ± .002", ± .004", ± .01" | |
| Error limit | mm | 0.004 | |
| Error limit over 50 graduations | mm | 0.002 | |
| Measuring force | N | 0.65 – 0.9 | |
| Standard | Factory standard | | |
| Protective measuring spindle cap | • | | |

| Order no. | a | b | c | Mounting shaft |
|-----------|-------|----|------|----------------|
| | mm | mm | mm | mm |
| 4337662 | 126.3 | 23 | 13.5 | 8 |

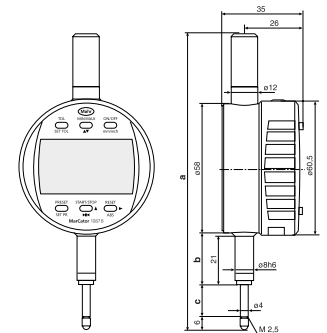

ACCESSORIES

| Order no. | Description | Type |
|-----------|---|--------|
| 4102357 | 16 EXu Data connection cable USB (2 m) | 16 EXu |
| 4102915 | Interface adapter with data cable Digimatic (2 m) | 16 EWd |
| 4102410 | Data connection cable RS232C (2 m) | 16 EXr |
| 4375004 | Protective cap for 1075 R / 1086 R / 1087 R | 1086 s |
| 4310103 | Adapter bushing (.375" / 8 mm) | 940 |

Small dial indicators

FEATURES

- High contrast dial face
- Adjustable tolerance markers
- Chrome plated housing
- Lifter protection cap on the measuring spindle
- Precision gears and pinions
- Package contains: case

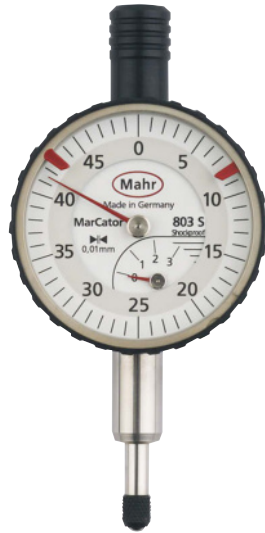

Application:

- To be used on all smaller indicating measuring instruments, or due to a confined space a smaller indicating instrument is required

TECHNICAL DATA

| Order no. | 4324000 | 4324050 | 4324060 |
|--|---------|-----------|---------|
| Type | 803 S | 803 A | 805 A |
| Measuring span | mm | 3 | 5 |
| Readings | mm | 0.01 | |
| Type of dial face | | 0 – 50 | 0 – 100 |
| Error limit, measuring range | µm | 10 | 12 |
| Error limit, 1 revolution | µm | 9 | 10 |
| Error limit, 1/2 revolution | µm | 8 | 9 |
| Error limit, 1/10 revolution | µm | 5 | |
| Repeatability f_w | µm | 3 | |
| Measuring value hysteresis f_u | µm | 3 | |
| Free stroke | mm | 0.1 | |
| Measuring force incoming measuring pin | N | 0.7 – 1.1 | |
| Standard | | DIN 878 | |
| Shockproof movement | | • | |
| Lifting protection cap | | | • |
| Scale diameter | mm | 34 | |
| Range per turn | mm | 0.5 | 1 |
| Dial color | | White | |

| Order no. | a | b | c | d | e | f | g | Mounting shaft |
|-----------|----|------|-----|----|----|------|-----|----------------|
| | mm | mm | mm | mm | mm | mm | mm | mm |
| 4324000 | 40 | 20.6 | 6.8 | 37 | 80 | 15.5 | 5.5 | 8 |
| 4324050 | 40 | 20.6 | 6.8 | 37 | 83 | 15 | 8 | 8 |
| 4324060 | 40 | 20.6 | 6.8 | 37 | 83 | 15 | 8 | 8 |

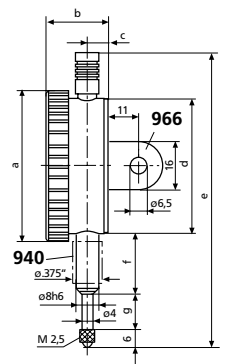

ACCESSORIES

| Order no. | Description | Type |
|-----------|--------------------------------|------|
| 4310103 | Adapter bushing (.375" / 8 mm) | 940 |
| 4375020 | Lug back, vertical, for 803 | 966 |
| 4375021 | Lug back, horizontal, for 803 | 967 |

Dial indicator

FEATURES

- High contrast dial face
- Adjustable tolerance markers
- Chrome plated housing
- Lifter protection cap on the measuring spindle
- Precision gears and pinions
- Package contains: case

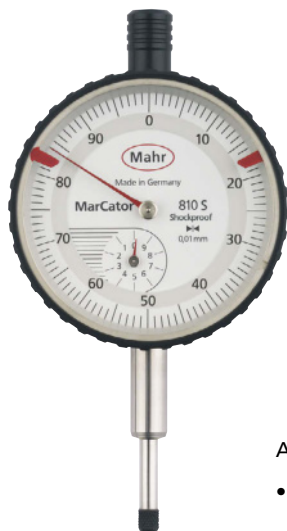

Application:

- 810 AU: The measuring pin is retracted by spring, contacting and the measuring force are triggered manually by pressing on the upper sleeve

TECHNICAL DATA

| Order no. | | 4311000 | 4311050 | 4311060 | 4321000 | 4329050 |
|--|----|---------|---------|---------|---------|------------------|
| Type | | 810 S | 810 A | 810 AT | 810 SV | 810 AU |
| Measuring span | mm | | 10 | | 40 | 10 |
| Readings | mm | | | 0.01 | | |
| Type of dial face | | 0–100 | | 100–0 | 0–100 | 100–0 |
| Error limit, measuring range | µm | | 15 | | 25 | 15 |
| Error limit, 1 revolution | µm | | 10 | | 15 | 10 |
| Error limit, 1/2 revolution | µm | | 9 | | 10 | 9 |
| Error limit, 1/10 revolution | µm | | | 5 | | |
| Repeatability f_w | µm | | 3 | | | 5 |
| Measuring value hysteresis f_u | µm | | 3 | | 6 | |
| Free stroke | mm | 0.1 | | 0.8 | | 0.1 |
| Generation of measuring force | | | | | | manual |
| Measuring force incoming measuring pin | N | | 0.7–1.3 | | 0.8–1.8 | - |
| Standard | | | DIN 878 | | | Factory standard |
| Shockproof movement | | • | | | • | |
| Lifting protection cap | | | | • | | |
| Reverse measuring force direction | | | | | | • |
| Scale diameter | mm | | | 50 | | |
| Range per turn | mm | | | 1 | | |
| Dial color | | | | White | | |

| Order no. | a | b | c | d | e | f | g | Mounting shaft |
|-----------|----|------|-----|----|-----|----|-----|----------------|
| | mm | mm | mm | mm | mm | mm | mm | mm |
| 4311000 | 58 | 23 | 7.5 | 52 | 112 | 21 | 16 | 8 |
| 4311050 | 58 | 23 | 7.5 | 52 | 112 | 22 | 15 | 8 |
| 4311060 | 58 | 23 | 7.5 | 52 | 112 | 22 | 15 | 8 |
| 4321000 | 58 | 24.2 | 8.7 | 52 | 169 | 22 | 45 | 8 |
| 4329050 | 58 | 23 | 7.5 | 52 | 112 | 22 | 4.5 | 8 |

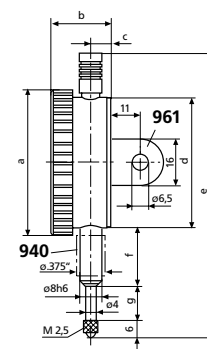

ACCESSORIES

| Order no. | Description | Type |
|-----------|--------------------------------|------|
| 4310103 | Adapter bushing (.375" / 8 mm) | 940 |
| 4373020 | Splash proof cap (58 mm) | 955 |
| 4375010 | Lug back, vertical, for 810 | 961 |
| 4375011 | Lug back, horizontal, for 810 | 962 |

MarCator 810 SM / 810 SRM

Dial indicator

FEATURES

- High contrast dial face
- Adjustable tolerance markers
- Chrome plated housing
- Lifter protection cap on the measuring spindle
- Precise mechanism with a combined gear lever transmission
- High accuracy with a minimum span of error
- **Package contains:** case



TECHNICAL DATA

| Order no. | | 4311070 | 4311080 |
|--|----|------------------|---------|
| Type | | 810 SM | 810 SRM |
| Measuring span | mm | 1 | 5 |
| Readings | mm | 0.001 | |
| Type of dial face | | 0–100 | 0–100–0 |
| Error limit, measuring range | µm | 4 | 10 |
| Error limit, 1 revolution | µm | 3 | 5 |
| Error limit, 1/2 revolution | µm | 2 | 4 |
| Error limit, 1/10 revolution | µm | 1 | 3 |
| Repeatability f_w | µm | 1.5 | 3 |
| Measuring value hysteresis f_u | µm | 1.5 | 3 |
| Free stroke | mm | 4 | 0.1 |
| Measuring force incoming measuring pin | N | 1.3–1.8 | 1.2–1.7 |
| Standard | | Factory standard | |
| Shockproof movement | | • | |
| Lifting protection cap | | • | |
| Scale diameter | mm | 50 | |
| Range per turn | mm | 0.1 | 0.2 |

| Order no. | a | b | c | d | e | f | g | Mounting shaft |
|-----------|----|----|-----|----|-------|----|----|----------------|
| | mm | mm | mm | mm | mm | mm | mm | mm |
| 4311070 | 58 | 23 | 8.5 | 52 | 111.5 | 22 | 15 | 8 |
| 4311080 | 58 | 23 | 7.5 | 52 | 111.5 | 22 | 15 | 8 |

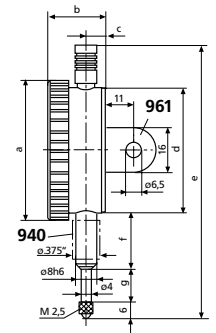

ACCESSORIES

| Order no. | Description | Type |
|-----------|--------------------------------|------|
| 4310103 | Adapter bushing (.375" / 8 mm) | 940 |
| 4373020 | Splash proof cap (58 mm) | 955 |
| 4375010 | Lug back, vertical, for 810 | 961 |
| 4375011 | Lug back, horizontal, for 810 | 962 |

MarCator 810 AX

Dial indicator

FEATURES

- High contrast dial face
- Adjustable tolerance markers
- Chrome plated housing
- Lifter protection cap on the measuring spindle
- Precision gears and pinions
- Package contains: case



TECHNICAL DATA

| Order no. | | 4331000 |
|--|----|------------------|
| Type | | 810 AX |
| Measuring span | mm | 10 |
| Readings | mm | 0.1 |
| Type of dial face | | 0–10 |
| Error limit, measuring range | μm | 50 |
| Error limit, 1 revolution | μm | 50 |
| Error limit, 1/2 revolution | μm | 40 |
| Error limit, 1/10 revolution | μm | 30 |
| Repeatability f_w | μm | 15 |
| Measuring value hysteresis f_u | μm | 15 |
| Free stroke | mm | 0.5 |
| Measuring force incoming measuring pin | N | 0.7–1.3 |
| Standard | | Factory standard |
| Lifting protection cap | | • |
| Scale diameter | mm | 50 |
| Range per turn | mm | 10 |
| Dial color | | White |

| Order no. | Mounting shaft |
|-----------|----------------|
| | mm |
| 4331000 | 8 |

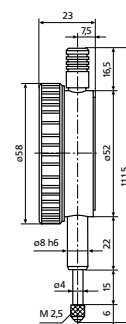

ACCESSORIES

| Order no. | Description | Type |
|-----------|--------------------------------|------|
| 4310103 | Adapter bushing (.375" / 8 mm) | 940 |
| 4373020 | Splash proof cap (58 mm) | 955 |
| 4375010 | Lug back, vertical, for 810 | 961 |
| 4375011 | Lug back, horizontal, for 810 | 962 |

MarCator 810 SW / 803 SW

Dial indicator with IP protection



FEATURES

- High contrast dial face
- Adjustable tolerance markers
- Chrome plated housing
- Precision gears and pinions
- Hermetically sealed upper protective measuring spindle cap, bezel and transparent dial cover; sealed with O-rings
- Measuring spindle sealed with rubber sleeve, thus preventing contamination by liquids and impurities
- IP protection category: IP 54
- Package contains: case

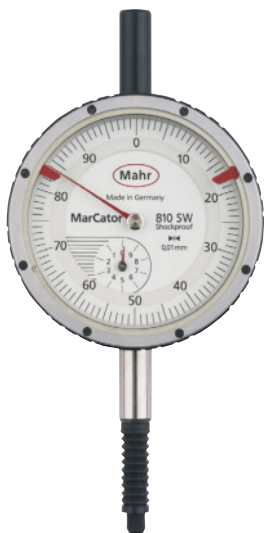

Application:

- Special design with IP protection against liquids and dust
- Ideal for use in particularly challenging environments where the dial gage is highly contaminated or exposed to splash water

TECHNICAL DATA

| Order no. | 4315000 | | 4326000 | |
|--|---------|-----------|---------|-----------|
| Type | 810 SW | | 803 SW | |
| Measuring span | mm | 10 | 3 | |
| Readings | mm | 0.01 | | |
| Type of dial face | 0 – 100 | | 0 – 50 | |
| Error limit, measuring range | µm | 15 | 10 | |
| Error limit, 1 revolution | µm | 10 | 9 | |
| Error limit, 1/2 revolution | µm | 9 | 8 | |
| Error limit, 1/10 revolution | µm | 5 | | |
| Repeatability f_w | µm | 3 | | |
| Measuring value hysteresis f_u | µm | 3 | | |
| Free stroke | mm | 0.1 | | |
| Measuring force incoming measuring pin | N | 0.7 – 1.6 | | 0.7 – 1.7 |
| Standard | DIN 878 | | | |
| Shockproof movement | • | | | |
| Protective measuring spindle cap | • | | | |
| Range per turn | mm | 1 | 0.5 | |
| Dial color | White | | | |

| Order no. | a | b | c | d | e | f | g | Mounting shaft |
|-----------|----|------|-----|----|-------|----|------|----------------|
| 4315000 | mm | mm | mm | mm | mm | mm | mm | mm |
| 4326000 | 61 | 24.2 | 7.9 | 52 | 127.6 | 22 | 22.1 | 8 |
| | 44 | 21.6 | 7.1 | 37 | 86 | 15 | 11 | 8 |

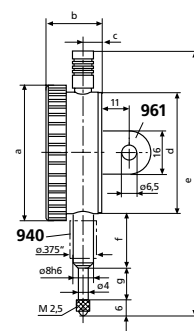

ACCESSORIES

| Order no. | Description | Type |
|-----------|--------------------------------|------|
| 4310103 | Adapter bushing (.375" / 8 mm) | 940 |
| 4375010 | Lug back, vertical, for 810 | 961 |
| 4375011 | Lug back, horizontal, for 810 | 962 |
| 4375020 | Lug back, vertical, for 803 | 966 |
| 4375021 | Lug back, horizontal, for 803 | 967 |

MarCator 810 AZ / 803 AZ

Dial indicator

FEATURES

- High contrast dial face
- Adjustable tolerance markers
- Chrome plated housing
- Lifter protection cap on the measuring spindle
- Precision gears and pinions
- **Package contains:** adapter bush 940, 8 mm to 3/8", case

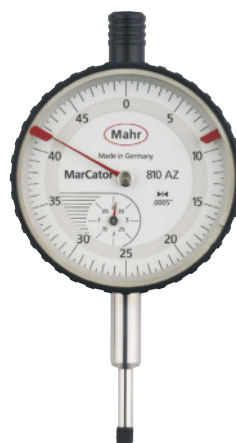

TECHNICAL DATA

| Order no. | 4311900 | | 4324900 | |
|--|------------------|---------|---------|-------|
| Type | 810 AZ | | 803 AZ | |
| Measuring span | inch | .400" | .120" | |
| Scale graduation value | inch | .0005" | | |
| Type of dial face | 0–50 | | 0–20 | |
| Range per turn | inch | .05" | .02" | |
| Error limit | inch | .0005" | .0004" | |
| Error limit, 1/10 revolution | inch | .0002" | | |
| Repeatability f_w | inch | .00012" | | |
| Repeatability f_w | inch | 0.0001 | | |
| Measuring value hysteresis f_u | inch | .00012" | | |
| Free stroke | inch | | | .008" |
| Measuring force incoming measuring pin | N | 0.9–1.5 | 0.7–1.1 | |
| Standard | Factory standard | | | |
| Lifting protection cap | • | | | |
| Scale diameter | inch | 1.97 | 1.4 | |
| Range per turn | inch | | | |
| Dial color | White | | | |

| Order no. | a | b | c | d | e | f | g | Mounting shaft | Mounting shaft |
|-----------|----|------|-----|----|-------|------|----|----------------|----------------|
| | mm | mm | mm | mm | mm | mm | mm | inch | mm |
| 4311900 | 58 | 23 | 7.5 | 52 | 111.5 | 22 | 15 | 0.375 | 8 |
| 4324900 | 40 | 20.6 | 6.8 | 37 | 83 | 15.5 | 8 | 0.375 | 8 |

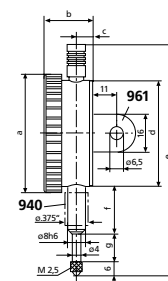

ACCESSORIES

| Order no. | Description | Type |
|-----------|--------------------------------|------|
| 4310103 | Adapter bushing (.375" / 8 mm) | 940 |
| 4373020 | Splash proof cap (58 mm) | 955 |
| 4375010 | Lug back, vertical, for 810 | 961 |
| 4375011 | Lug back, horizontal, for 810 | 962 |
| 4375020 | Lug back, vertical, for 803 | 966 |
| 4375021 | Lug back, horizontal, for 803 | 967 |

Safety dial indicator

FEATURES

- High contrast dial face
- Adjustable tolerance markers
- Chrome plated housing
- Hermetically sealed protective measuring spindle cap
- Limited measuring range for error free readings
- Large overtravel (ca. 9 mm) for easier insertion of test items in measuring devices
- Precision gears and pinions
- Package contains: case

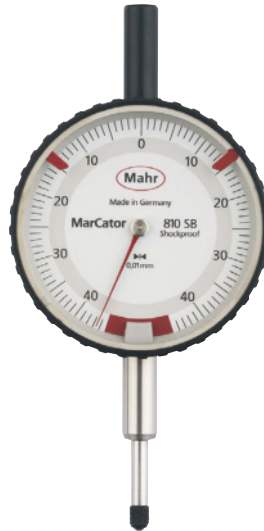

Applications:

- For safety reasons, the indication range of these dial indicators is limited to just under one pointer rotation.
- This prevents the risk of measuring errors arising from possible additional pointer rotations.

TECHNICAL DATA

| Order no. | | 4317000 | 4324250 |
|--|----|-----------|-----------|
| Type | | 810 SB | 803 SB |
| Measuring span | mm | 0.8 | 0,4 |
| Readings | mm | | 0.01 |
| Type of dial face | | 40 –0 –40 | 20 –0 –20 |
| Error limit, measuring range | µm | | 7 |
| Error limit, 1/2 revolution | µm | | 6 |
| Error limit, 1/10 revolution | µm | | 5 |
| Repeatability f_w | µm | | 3 |
| Measuring value hysteresis f_u | µm | | 3 |
| Free stroke | mm | 9 | 4.5 |
| Measuring force incoming measuring pin | N | 0.9 –1.1 | 0.7 –1.1 |
| Standard | | | DIN 878 |
| Shockproof movement | | | • |
| Protective measuring spindle cap | | | • |
| Range per turn | mm | 0.8 | |
| Dial color | | | White |

| Order no. | a | b | c | d | e | f | g | Mounting shaft |
|-----------|----|------|-----|----|-----|------|----|----------------|
| | mm | mm | mm | mm | mm | mm | mm | mm |
| 4317000 | 58 | 23 | 7.5 | 52 | 120 | 22 | 15 | 8 |
| 4324250 | 44 | 21.6 | 6.8 | 37 | 83 | 15.5 | 8 | 8 |

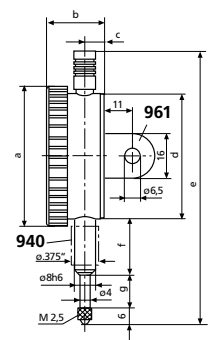

ACCESSORIES

| Order no. | Description | Type |
|-----------|--------------------------------|------|
| 4310103 | Adapter bushing (.375" / 8 mm) | 940 |
| 4375010 | Lug back, vertical, for 810 | 961 |
| 4375011 | Lug back, horizontal, for 810 | 962 |
| 4375020 | Lug back, vertical, for 803 | 966 |
| 4375021 | Lug back, horizontal, for 803 | 967 |

MarCator 810 AG

Large dial indicator

FEATURES

- Large, high contrast dial face
- Adjustable tolerance markers
- Chrome plated housing
- Lifter protection cap on the measuring spindle
- Precision gears and pinions

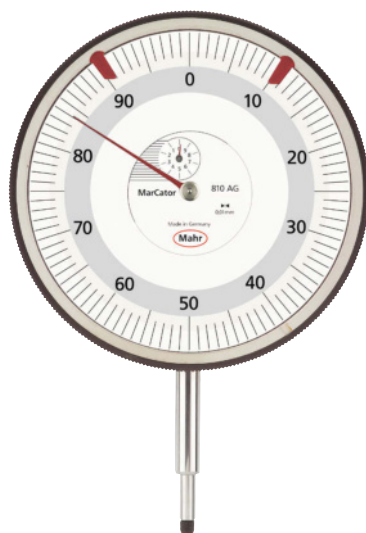

Application:

- Ideal for long reading distance and in poorly lit conditions

TECHNICAL DATA

| Order no. | | 4322000 |
|--|----|------------------|
| Type | | 810 AG |
| Measuring span | mm | 10 |
| Readings | mm | 0.01 |
| Type of dial face | | 0–100 |
| Error limit, measuring range | μm | 17 |
| Error limit, 1 revolution | μm | 15 |
| Error limit, 1/2 revolution | μm | 10 |
| Error limit, 1/10 revolution | μm | 5 |
| Repeatability f_w | μm | 3 |
| Measuring value hysteresis f_u | μm | 5 |
| Free stroke | mm | 0.1 |
| Measuring force incoming measuring pin | N | 1.3–2.2 |
| Standard | | Factory standard |
| Lifting protection cap | | • |
| Scale diameter | mm | 112 |
| Range per turn | mm | 1 |
| Dial color | | White |

| Order no. | Mounting shaft |
|-----------|----------------|
| | mm |
| 4322000 | 8 |

ACCESSORIES

| Order no. | Description | Type |
|-----------|--------------------------------|------|
| 4310103 | Adapter bushing (.375" / 8 mm) | 940 |

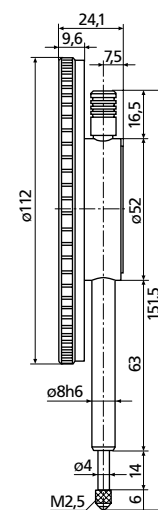

MarCator 901 / 901 H / 901 R

Standard contact point

| Order no. | Product type | l | Measurement surface radius | Measuring surface |
|-----------|--------------|----|----------------------------|-------------------|
| | | mm | mm | |
| 4360001 | 901 | 6 | 1.5 | steel |
| 4360002 | 901 H | 6 | 1.5 | carbide |
| 4360003 | 901 R | 6 | 1.5 | ruby |

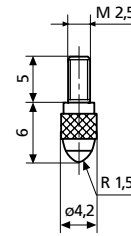

MarCator 902

Spherical contact point

| Order no. | Product type | l | Measuring surface ϕ | Measurement surface radius | Measuring surface |
|-----------|--------------|----|--------------------------|----------------------------|-------------------|
| | | mm | mm | mm | |
| 4360007 | 902 | 4 | 4 | 6 | steel |
| 4360009 | 902 | 6 | 4 | 6 | steel |
| 4360010 | 902 | 8 | 4 | 6 | steel |
| 4360011 | 902 | 10 | 4 | 6 | steel |
| 4360012 | 902 | 12 | 4 | 6 | steel |
| 4360013 | 902 | 15 | 4 | 6 | steel |
| 4360014 | 902 | 20 | 4 | 6 | steel |
| 4360015 | 902 | 25 | 4 | 6 | steel |
| 4360018 | 902 | 50 | 4 | 6 | steel |

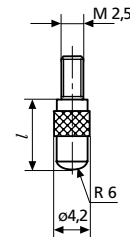

MarCator 902 H

Spherical contact point

| Order no. | Product type | l | Measuring surface ϕ | Measurement surface radius | Measuring surface |
|-----------|--------------|----|--------------------------|----------------------------|-------------------|
| | | mm | mm | mm | |
| 4360040 | 902 H | 8 | 4 | 6 | carbide |
| 4360041 | 902 H | 10 | 4 | 6 | carbide |
| 4360042 | 902 H | 12 | 4 | 6 | carbide |
| 4360043 | 902 H | 15 | 4 | 6 | carbide |
| 4360044 | 902 H | 20 | 4 | 6 | carbide |
| 4360045 | 902 H | 25 | 4 | 6 | carbide |
| 4360048 | 902 H | 50 | 4 | 6 | carbide |

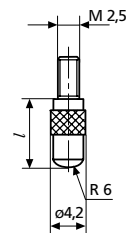

MarCator 903 / 903 H

Flat contact point

| Order no. | Product type | l | Measuring surface ϕ | Measuring surface |
|-----------|--------------|----|--------------------------|-------------------|
| | | mm | mm | |
| 4360070 | 903 | 4 | 4 | steel |
| 4360071 | 903 | 6 | 4 | steel |
| 4360072 | 903 | 8 | 4 | steel |
| 4360073 | 903 | 10 | 4 | steel |
| 4360074 | 903 | 12 | 4 | steel |
| 4360075 | 903 | 15 | 4 | steel |
| 4360076 | 903 | 20 | 4 | steel |
| 4360077 | 903 | 25 | 4 | steel |
| 4360300 | 903 | 30 | 4 | steel |
| 4360078 | 903 | 35 | 4 | steel |
| 4360079 | 903 | 50 | 4 | steel |
| 4360101 | 903 H | 6 | 4 | carbide |
| 4360102 | 903 H | 8 | 4 | carbide |
| 4360103 | 903 H | 10 | 4 | carbide |
| 4360104 | 903 H | 12 | 4 | carbide |
| 4360105 | 903 H | 15 | 4 | carbide |
| 4360106 | 903 H | 20 | 4 | carbide |
| 4360107 | 903 H | 25 | 4 | carbide |
| 4360110 | 903 H | 30 | 4 | carbide |
| 4360108 | 903 H | 35 | 4 | carbide |
| 4360111 | 903 H | 40 | 4 | carbide |
| 4360310 | 903 | 40 | 4 | steel |
| 4360109 | 903 H | 50 | 4 | carbide |

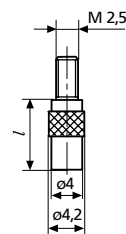

MarCator 904 / 904 H

Conical contact point

| Order no. | Product type | l | Measurement surface radius | Angle α | Measuring surface |
|-----------|--------------|----|----------------------------|----------------|-------------------|
| | | mm | mm | ° | |
| 4360130 | 904 | 10 | 0.3 | 30 | steel |
| 4360131 | 904 H | 10 | 0.3 | 30 | carbide |

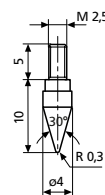

MarCator 905 / 905 H

Wedge shaped contact points

| Order no. | Product type | l | Measuring surface ϕ | Measurement surface radius | Measuring surface |
|-----------|--------------|----|--------------------------|----------------------------|-------------------|
| | | mm | mm | mm | |
| 4360140 | 905 | 10 | 4 | 0.3 | steel |
| 4360141 | 905 H | 10 | 4 | 0.3 | carbide |

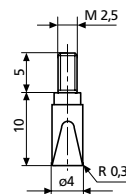

MarCator 906 H

Ball contact points

| Order no. | Product type | d | l | Measuring surface |
|-----------|--------------|------|-----|-------------------|
| | | mm | mm | |
| 4360150 | 906 H | 1 | 8.5 | carbide |
| 4360151 | 906 H | 1.25 | 8.5 | carbide |
| 4360152 | 906 H | 1.5 | 8.5 | carbide |
| 4360153 | 906 H | 1.75 | 8.5 | carbide |
| 4360154 | 906 H | 2 | 8.5 | carbide |
| 4360155 | 906 H | 2.5 | 8.5 | carbide |
| 4360156 | 906 H | 3 | 8.5 | carbide |
| 4360157 | 906 H | 3.5 | 8.5 | carbide |
| 4360158 | 906 H | 4 | 8.5 | carbide |
| 4360159 | 906 H | 4.5 | 8.5 | carbide |
| 4360160 | 906 H | 5 | 9 | carbide |
| 4360161 | 906 H | 5.5 | 9 | carbide |
| 4360162 | 906 H | 6 | 9 | carbide |
| 4360163 | 906 H | 6.35 | 9 | carbide |
| 4360164 | 906 H | 6.5 | 10 | carbide |
| 4360165 | 906 H | 7 | 10 | carbide |
| 4360166 | 906 H | 7.5 | 11 | carbide |
| 4360167 | 906 H | 8 | 11 | carbide |
| 4360168 | 906 H | 8.5 | 12 | carbide |
| 4360169 | 906 H | 9 | 12 | carbide |
| 4360170 | 906 H | 10 | 13 | carbide |

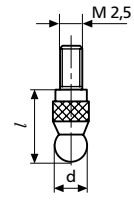

MarCator 907 / 907 H

Flat contact plates

| Order no. | Product type | l | Measuring surface | Measuring surface ϕ | Measuring surface |
|-----------|--------------|----|-------------------|--------------------------|-------------------|
| | | mm | cm ² | mm | |
| 4360200 | 907 | 5 | 1 | 11.3 | steel |
| 4360201 | 907 H | 5 | | 7 | carbide |

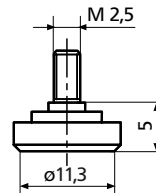

MarCator 908 / 908 H

Spherical contact plates, steel

| Order no. | Product type | l | Measuring surface ϕ | Measurement surface radius | Measuring surface |
|-----------|--------------|----|--------------------------|----------------------------|-------------------|
| | | mm | mm | mm | |
| 4360210 | 908 | 5 | 12 | 30 | steel |
| 4360211 | 908 H | 5 | 12 | 30 | carbide |

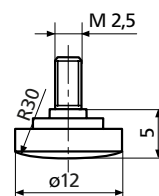

MarCator 909 A / 909 B

Measuring rollers

| Order no. | Product type | l | Measurement surface radius | Radial run-out deviation | Measuring surface |
|-----------|--------------|----|----------------------------|--------------------------|-------------------|
| | | mm | mm | μm | |
| 4360220 | 909 A | 18 | | 3 | steel |
| 4360221 | 909 B | 18 | 5 | 3 | steel |

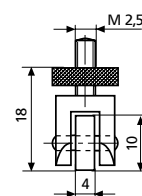

MarCator 910 H

Measuring attachment

| Order no. | Product type | l | Measuring surface |
|-----------|--------------|----|-------------------|
| | | mm | |
| 4360230 | 910 H | 22 | carbide |

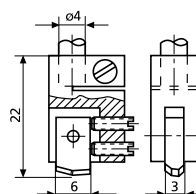

MarCator 911 H1 / 911 H2 / 911

Pin contact point

| Order no. | Product type | l | Measuring surface ϕ | Measuring surface |
|-----------|--------------|----|--------------------------|-------------------|
| | | mm | mm | |
| 4360240 | 911 H1 | 2 | 1 | carbide |
| 4360241 | 911 H2 | 11 | 1.5 | carbide |
| 4360280 | 911 | 15 | 1.5 | steel |
| 4360281 | 911 | 20 | 1.5 | steel |
| 4360282 | 911 | 25 | 1.5 | steel |
| 4360283 | 911 | 30 | 1.5 | steel |
| 4360284 | 911 | 35 | 1.5 | steel |
| 4360285 | 911 | 40 | 1.5 | steel |
| 4360286 | 911 | 50 | 1.5 | steel |

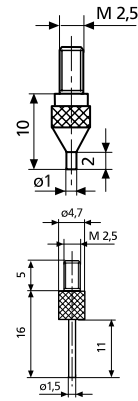

MarCator 912

Measuring spindle extension

| Order no. | Product type | d | l |
|-----------|--------------|----|-----|
| | | mm | mm |
| 4360250 | 912 | 4 | 10 |
| 4360251 | 912 | 4 | 15 |
| 4360252 | 912 | 4 | 20 |
| 4360253 | 912 | 4 | 25 |
| 4360254 | 912 | 4 | 35 |
| 4360255 | 912 | 4 | 50 |
| 4360256 | 912 | 4 | 75 |
| 4360257 | 912 | 4 | 100 |

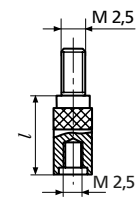

MarCator 913

Flat contact point

| Order no. | Product type | Measuring surface ϕ |
|-----------|--------------|--------------------------|
| | | mm |
| 4360400 | 913 | 7.5 |

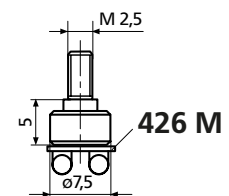

MarCator 941 G

Straight holder

FEATURES

- For measuring devices and in combination with standard measuring instruments, where the measuring instrument has to be moved away.
- **Package contains:**
contact point 901



Applications:

- For all types of measuring devices
- To be used in conjunction with a dial indicator or an inductive probe
- To position the measuring instrument at a certain angle

TECHNICAL DATA

| Order no. | Length l1 | Transmission | Type |
|-----------|-----------|--------------|-------|
| | mm | | |
| 4365000 | 25 | 3 mm | 941 G |
| 4365001 | 50 | 3 mm | 941 G |
| 4365002 | 75 | 3 mm | 941 G |

| Order no. | Length l1 |
|-----------|-----------|
| | mm |
| 4365000 | 25 |
| 4365001 | 50 |
| 4365002 | 75 |

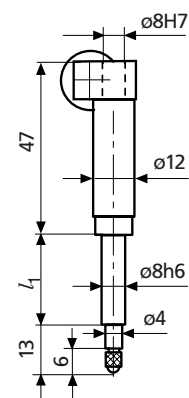

MarCator 941 W

Angular holder

FEATURES

- For measuring devices and in combination with standard measuring instruments, where tilting of the measuring instrument is required.
- **Package contains:** contact point 901, contact point 903 (l = 10 mm)



Applications:

- For all types of measuring devices
- To be used in conjunction with a dial indicator or an inductive probe
- To be positioned (tilted) at the measurement direction and also at a certain distance or angle

TECHNICAL DATA

| Order no. | Length I1 | Length I2 | Transmission | Type |
|-----------|-----------|-----------|--------------|-------|
| | mm | mm | | |
| 4365010 | 25 | 53.7 | 3 mm | 941 W |
| 4365011 | 50 | 53.7 | 3 mm | 941 W |
| 4365012 | 75 | 53.7 | 3 mm | 941 W |
| 4365020 | 25 | 49.3 | 3 mm | 941 W |
| 4365021 | 50 | 49.3 | 3 mm | 941 W |
| 4365022 | 75 | 49.3 | 3 mm | 941 W |
| 4365030 | 25 | 34.5 | 3 mm | 941 W |
| 4365031 | 50 | 34.5 | 3 mm | 941 W |
| 4365032 | 75 | 34.5 | 3 mm | 941 W |

| Order no. | Angle α | Length I1 | Length I2 |
|-----------|----------------|-----------|-----------|
| | ° | mm | mm |
| 4365010 | 45 | 25 | 53.7 |
| 4365011 | 45 | 50 | 53.7 |
| 4365012 | 45 | 75 | 53.7 |
| 4365020 | 60 | 25 | 49.3 |
| 4365021 | 60 | 50 | 49.3 |
| 4365022 | 60 | 75 | 49.3 |
| 4365030 | 90 | 25 | 34.5 |
| 4365031 | 90 | 50 | 34.5 |
| 4365032 | 90 | 75 | 34.5 |

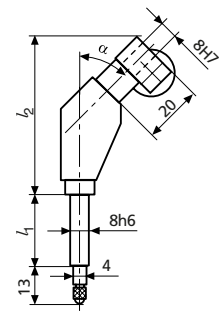

MarCator 943

Sensor level

FEATURES

- Integrated lifting device
- Interchangeable measuring anvil
- Package contains: contact point 901

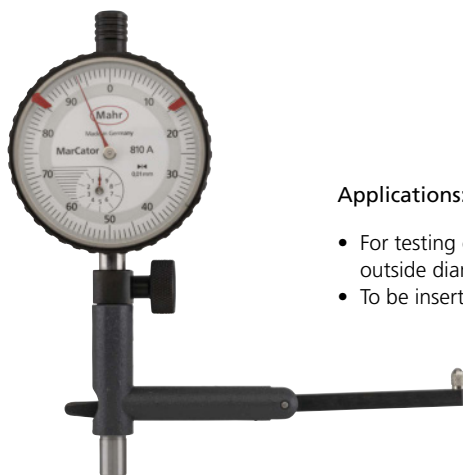

Applications:

- For testing concentricity in bore holes as well as difficult-to-reach outside diameters
- To be inserted in a measuring stand with a lifting device

TECHNICAL DATA

| Order no. | Error limit | Transmission | Type |
|-----------|----------------------|--------------|------|
| 4367000 | 1% of measuring path | +/- 1mm | 943 |

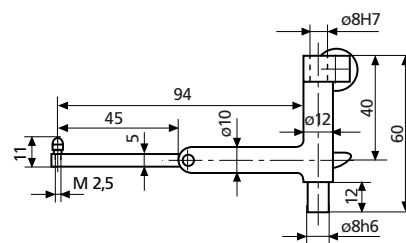

1086 R; 1086 ZR

MarCator 837

Dial indicator depth measuring bridge

FEATURES

- Measuring surface plane and precision lapped
- Holder for dial indicators with shaft diameter 8 mm
- Made of hardened steel, hard chrome plated
- **Package contains:** depth measuring bridge, contact point 902 (l = 12 mm), excludes indicator



Application:

- For precise depth measurement using dial indicator

TECHNICAL DATA

| | | | |
|-----------|---------|---------|---------|
| Order no. | 4494010 | 4494011 | 4494012 |
| Type | | 837 | |

ACCESSORIES

| Order no. | Description | Type |
|-----------|--|--------|
| 4311060 | Dial indicator, 0.01, 10 mm | 810 AT |
| 4336010 | Digital indicator, 0.01 mm, 12.5 mm | 1075 R |
| 4337131 | Digital indicator, 0.01 mm, 25 mm | 1086 R |
| 4360015 | Spherical contact point, hardened steel, l = 25 mm, r = 6 mm | 902 |
| 4360017 | Spherical contact point, hardened steel, l = 35 mm, r = 6 mm | 902 |
| 4360026 | Spherical contact point, hardened steel, l = 45 mm, r = 6 mm | 902 |
| 4360031 | Spherical contact point, hardened steel, l = 55 mm, r = 6 mm | 902 |
| 4360035 | Spherical contact point, hardened steel, l = 65 mm, r = 6 mm | 902 |
| 4360020 | Spherical contact point, hardened steel, l = 75 mm, r = 6 mm | 902 |
| 4360036 | Spherical contact point, hardened steel, l = 85 mm, r = 6 mm | 902 |
| 4360029 | Spherical contact point, hardened steel, l = 95 mm, r = 6 mm | 902 |



810 AT



1075 R



1086 R, 1086 ZR

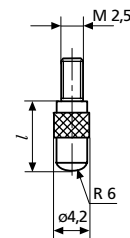

902, 902 H

MarCator A1/2Q / A3Q / A6Q

Dial indicator

FEATURES

- Unit construction and removable movement save repair/cleaning time and maintenance
- Hardened gears and stainless steel racks provide lasting protection against indicator failure due to shock or wear
- Jeweled bearings resist friction, add to longer indicator life
- Skeletonized, hobbled gears for more sensitive response, superior indicator accuracy with minimal hysteresis error
- Soft tinted dials (green - inch / yellow - metric) minimize eye strain
- Special steel alloy
- Balanced dial hand affords no shift, precise reading
- Controlled rack and pinion mesh eliminates slope for precise response and reading
- Smooth adjusting bezels for easy setup
- Positive pressure pullback spring requires less maintenance
- Compliance with ANSI/AGD dimensional and accuracy specifications
- Normally furnished: balanced dial with + on right; centered vertical lug back; regular contact point PT-43, .09" radiused, .093" long
- Optional dials: balanced with + on left; continuous clockwise; continuous counterclockwise
- Order by part number and specify dial style desired - for other dial styles or special requirements, call Mahr



Application:

- Where available space prohibits the use of longer dial indicators

TECHNICAL DATA

| Order no. | Type | Measuring span | Scale graduation value | Figure on dial face | Range per turn | Error limit, measuring range | Error limit | Standard | ANSI/AGD group |
|-----------|-------|----------------|------------------------|---------------------|----------------|------------------------------|-------------|----------|----------------|
| 2011089 | A1/2Q | .010" | .0001" | 0-2-0 | .004" | 0.0002 | ± .0001" | ANSI | 0 |
| 2011093 | A3Q | .050" | .0005" | 0-10-0 | .020" | 0.001 | ± .0005" | ANSI | 0 |
| 2011095 | A6Q | .100" | .001" | 0-20-0 | .040" | 0.001 | ± .001" | ANSI | 0 |

| Order no. | Scale diameter | Range per turn | Dial color | Mounting shaft |
|-----------|----------------|----------------|------------|----------------|
| | inch | inch | | inch |
| 2011089 | 1.25 | 0.0040 | Green | 0.22 |
| 2011093 | 1.25 | 0.0200 | Green | 0.22 |
| 2011095 | 1.25 | 0.0400 | Green | 0.22 |

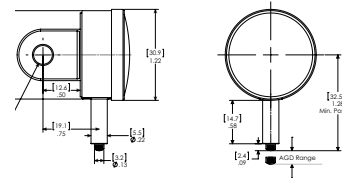

ACCESSORIES

| Order no. | Description | Type |
|-----------|--|--------|
| 2202329 | Contact point, flat | AL-61 |
| 2204777 | Flat back | BK-32 |
| 2204778 | Lug back | BK-37 |
| 2204779 | Post back 7/32" | BK-38 |
| 2204785 | Adjustable back | BK-45 |
| 2204809 | Screw type back 1/4-28 | BK-88 |
| 2205082 | Split bushing .218" x .374" x .5" | BU-112 |
| 2225757 | Contact point, spherical | PT-118 |
| 2225758 | Contact point, taper | PT-119 |
| 2225801 | Contact point, spherical, A = 1/4" | PT-204 |
| 2225802 | Contact point, spherical, A = 3/8" | PT-205 |
| 2225804 | Contact point, spherical, A = 1/2" | PT-207 |
| 2225805 | Contact point, spherical, A = 5/8" | PT-208 |
| 2225806 | Contact point, spherical, A = 3/4" | PT-209 |
| 2225808 | Contact point, spherical, A = 7/8" | PT-210 |
| 2225809 | Contact point, spherical, A = 1" | PT-211 |
| 2225925 | Contact point, spherical, A = 3/32" (normally furnished) | PT-43 |

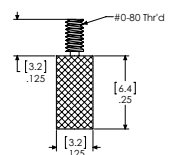

AL-61

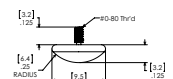

PT-118

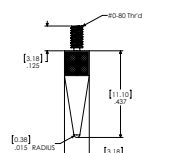

PT-119

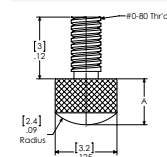

PT-204;PT-205;
PT-207;PT-208;
PT-209;PT-210;
PT-211;PT-43

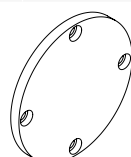

BK-32;
BK-470;
BK-473;
BK-5

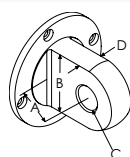

BK-37

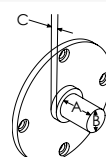

BK-38



BK-45

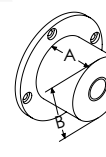

BK-88

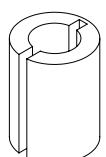

BU-112

MarCator N1/2O / N3I / N6I

Dial indicator

FEATURES

- Unit construction and removable movement save repair/cleaning time and maintenance
- Hardened gears and stainless steel racks provide lasting protection against indicator failure due to shock or wear
- Jeweled bearings resist friction, add to longer indicator life
- Skeletonized, hobbed gears for more sensitive response, superior indicator accuracy with minimal hysteresis error
- Soft tinted dials (green - inch / yellow - metric) minimize eye strain
- Special steel alloy
- Balanced dial hand affords no shift, precise reading
- Controlled rack and pinion mesh eliminates slope for precise response and reading
- Smooth adjusting bezels for easy setup
- Positive pressure pullback spring requires less maintenance
- Compliance with ANSI/AGD dimensional and accuracy specifications
- Normally furnished: balanced dial with + on right; centered vertical lug back; regular contact point PT-43, .09" radiused, .093" long
- Optional dials: balanced with + on left; continuous clockwise; continuous counterclockwise
- Order by part number and specify dial style desired - for other dial styles or special requirements, call Mahr



Application:

- Where available space prohibits the use of longer dial indicators

TECHNICAL DATA

| Order no. | Type | Measuring span | Readings | Figure on dial face | Error limit, measuring range | Error limit | Standard |
|-----------|-------|----------------|----------|---------------------|------------------------------|-------------|----------|
| | | mm | mm | | µm | mm | |
| 2011743 | N1/2O | 0.25 | 0.002 | 0-5-0 | 4 | ± 0.002 | ANSI |
| 2011745 | N3I | 1.25 | 0.005 | 0-25-0 | 10 | ± 0.005 | ANSI |
| 2011759 | N6I | 2.5 | 0.01 | 0-50-0 | 20 | ± 0.01 | ANSI |

| Order no. | ANSI/AGD group | Range per turn | Dial color | Mounting shaft |
|-----------|----------------|----------------|------------|----------------|
| | | mm | | inch |
| 2011743 | 0 | 0.1 | Yellow | 0.22 |
| 2011745 | 0 | 0.5 | Yellow | 0.22 |
| 2011759 | 0 | 1 | Yellow | 0.22 |

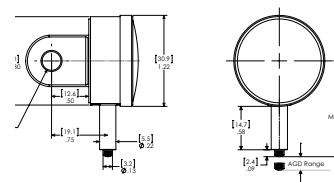

ACCESSORIES

| Order no. | Description | Type |
|-----------|--|--------|
| 2202329 | Contact point, flat | AL-61 |
| 2204777 | Flat back | BK-32 |
| 2204778 | Lug back | BK-37 |
| 2204779 | Post back 7/32" | BK-38 |
| 2204785 | Adjustable back | BK-45 |
| 2204809 | Screw type back 1/4-28 | BK-88 |
| 2205082 | Split bushing .218" x .374" x .5" | BU-112 |
| 2225757 | Contact point, spherical | PT-118 |
| 2225758 | Contact point, taper | PT-119 |
| 2225801 | Contact point, spherical, A = 1/4" | PT-204 |
| 2225802 | Contact point, spherical, A = 3/8" | PT-205 |
| 2225804 | Contact point, spherical, A = 1/2" | PT-207 |
| 2225805 | Contact point, spherical, A = 5/8" | PT-208 |
| 2225806 | Contact point, spherical, A = 3/4" | PT-209 |
| 2225808 | Contact point, spherical, A = 7/8" | PT-210 |
| 2225809 | Contact point, spherical, A = 1" | PT-211 |
| 2225925 | Contact point, spherical, A = 3/32" (normally furnished) | PT-43 |

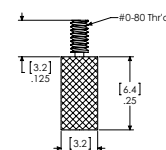

AL-61

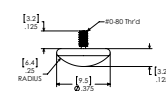

PT-118

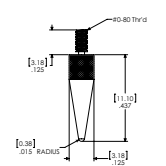

PT-119

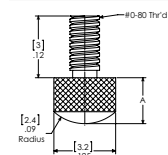

PT-204;PT-205;
PT-207;PT-208;
PT-209;PT-210;
PT-211;PT-43

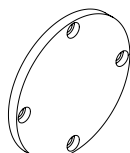

BK-32;
BK-470;
BK-473;
BK-5

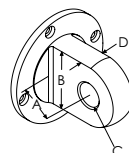

BK-37

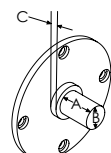

BK-38

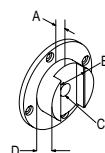

BK-45

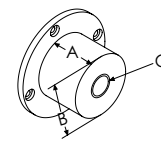

BK-88

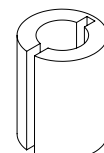

BU-112

MarCator

Dial indicator

FEATURES

- Unit construction and removable movement save repair/cleaning time and maintenance
- Hardened gears and stainless steel racks provide lasting protection against indicator failure due to shock or wear
- Jeweled bearings resist friction, add to longer indicator life
- Skeletonized, hobbled gears for more sensitive response, superior indicator accuracy with minimal hysteresis error
- Soft tinted dials (green - inch / yellow - metric) minimize eye strain
- Special steel alloy
- Balanced dial hand affords no shift, precise reading
- Controlled rack and pinion mesh eliminates slope for precise response and reading
- Smooth adjusting bezels for easy setup
- Positive pressure pull back spring requires less maintenance
- Compliance with ANSI/AGD dimensional and accuracy specifications
- These indicators are normally furnished with continuous dial (with R.C.) or + on right balance dial (w/o R.C.), lug back and .18" by .250" long contact
- Optional Dials: balanced dial with + on left; continuous clockwise; continuous counterclockwise (Order by part number and specify dial style desired)
- For other dial styles or special requirements - call Mahr



TECHNICAL DATA

| Order no. | Type | Measuring span | Scale graduation value | Figure on dial face | Rev. counter | Range per turn | Error limit, measuring range | Error limit | Standard |
|-----------|--------|----------------|------------------------|---------------------|--------------|----------------|------------------------------|-------------|----------|
| | | inch | inch | | | inch | inch | inch | |
| 2011000 | 12I | .025" | .0001" | 0-5-0 | | .010" | 0.0002 | ±.0001" | ANSI |
| 2011001 | 12I-RC | .025" | .0001" | 0-10 | • | .010" | 0.0002 | ±.0001" | ANSI |
| 2011004 | 12Q | .025" | .00025" | 0-5-0 | | .010" | 0.0005 | ±.00025" | ANSI |
| 2011005 | 12Q-RC | .025" | .00025" | 0-10 | • | .010" | 0.0005 | ±.00025" | ANSI |
| 2011106 | B3K | .050" | .00025" | 0-10-0 | | .020" | 0.0005 | ±.00025" | ANSI |
| 2011107 | B3K-RC | .050" | .00025" | 0-20 | • | .020" | 0.0005 | ±.00025" | ANSI |
| 2011110 | B3Q | .050" | .0005" | 0-10-0 | | .020" | 0.001 | ±.0005" | ANSI |
| 2011111 | B3Q-RC | .050" | .0005" | 0-20 | • | .020" | 0.001 | ±.0005" | ANSI |
| 2011114 | B3W | .050" | .001" | 0-10-0 | | .020" | 0.002 | ±.001" | ANSI |
| 2011115 | B3W-RC | .050" | .001" | 0-20 | • | .020" | 0.002 | ±.001" | ANSI |
| 2011118 | B5M | .075" | .0005" | 0-15-0 | | .030" | 0.001 | ±.0005" | ANSI |
| 2011119 | B5M-RC | .075" | .0005" | 0-30 | • | .030" | 0.001 | ±.0005" | ANSI |
| 2011123 | B6K | .100" | .0005" | 0-20-0 | | .040" | 0.001 | ±.0005" | ANSI |
| 2011124 | B6K-RC | .100" | .0005" | 0-40 | • | .040" | 0.001 | ±.0005" | ANSI |
| 2011128 | B6Q | .100" | .001" | 0-20-0 | | .040" | 0.002 | ±.001" | ANSI |
| 2011129 | B6Q-RC | .100" | .001" | 0-40 | • | .040" | 0.002 | ±.001" | ANSI |
| 2011133 | B7I | .125" | .0005" | 0-25-0 | | .050" | 0.001 | ±.0005" | ANSI |
| 2011134 | B7I-RC | .125" | .0005" | 0-50 | • | .050" | 0.001 | ±.0005" | ANSI |
| 2011137 | B7O | .125" | .001" | 0-25-0 | | .050" | 0.002 | ±.001" | ANSI |
| 2011138 | B7O-RC | .125" | .001" | 0-50 | • | .050" | 0.002 | ±.001" | ANSI |
| 2011141 | B8I | .250" | .001" | 0-50-0 | | .100" | 0.002 | ±.001" | ANSI |
| 2011142 | B8I-RC | .250" | .001" | 0-100 | • | .100" | 0.002 | ±.001" | ANSI |

| Order no. | ANSI/AGD group | Scale diameter | Range per turn | Dial color | Mounting shaft |
|-----------|----------------|----------------|----------------|------------|----------------|
| | | inch | inch | | inch |
| 2011000 | 1 | 1.75 | 0.0100 | Green | 0.375 |
| 2011001 | 1 | 1.75 | 0.0100 | Green | 0.375 |
| 2011004 | 1 | 1.75 | 0.0100 | Green | 0.375 |
| 2011005 | 1 | 1.75 | 0.0100 | Green | 0.375 |
| 2011106 | 1 | 1.75 | 0.0200 | Green | 0.375 |
| 2011107 | 1 | 1.75 | 0.0200 | Green | 0.375 |
| 2011110 | 1 | 1.75 | 0.0200 | Green | 0.375 |
| 2011111 | 1 | 1.75 | 0.0200 | Green | 0.375 |
| 2011114 | 1 | 1.75 | 0.0200 | Green | 0.375 |
| 2011115 | 1 | 1.75 | 0.0200 | Green | 0.375 |
| 2011118 | 1 | 1.75 | 0.0300 | Green | 0.375 |
| 2011119 | 1 | 1.75 | 0.0300 | Green | 0.375 |
| 2011123 | 1 | 1.75 | 0.0400 | Green | 0.375 |
| 2011124 | 1 | 1.75 | 0.0400 | Green | 0.375 |
| 2011128 | 1 | 1.75 | 0.0400 | Green | 0.375 |
| 2011129 | 1 | 1.75 | 0.0400 | Green | 0.375 |
| 2011133 | 1 | 1.75 | 0.0500 | Green | 0.375 |
| 2011134 | 1 | 1.75 | 0.0500 | Green | 0.375 |
| 2011137 | 1 | 1.75 | 0.0500 | Green | 0.375 |
| 2011138 | 1 | 1.75 | 0.0500 | Green | 0.375 |
| 2011141 | 1 | 1.75 | 0.1000 | Green | 0.375 |
| 2011142 | 1 | 1.75 | 0.1000 | Green | 0.375 |

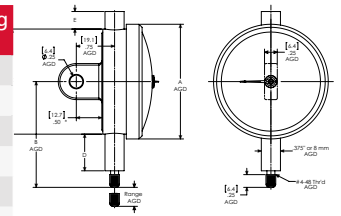

ACCESSORIES

| Order no. | Description | Type |
|-----------|---|-----------|
| 2203132 | Mounting bracket with adjusting knob | AT-115 |
| 2203155 | Mounting bracket with hex socket adjust | AT-27 |
| 2204756 | Vertical lug back, centered, 1/4" hole | BK-1600 |
| 2204757 | Vertical lug back, offset, 1/4" hole | BK-1601 |
| 2204758 | Adjustable back 1/4"-20 thread | BK-1633 |
| 2204759 | Post back 1/2" | BK-1634 |
| 2204760 | Flat back | BK-1660 |
| 2204761 | Screw type back 1/4-28 | BK-1661 |
| 2204771 | Horizontal lug back 1/4" hole | BK-19 |
| 2204811 | Rack back used on AT-27 and AT-115 | BK-92 |
| 2220156 | Tolerance hands with screw on bezel (option) | HD-59 |
| 2220542 | Lifting lever, left hand | LR-46 |
| 2220543 | Lifting lever, right hand | LR-47 |
| 2220539 | OX-bow lifting lever | LR-40 |
| 2203183 | Brake attachment (option) | AT-A-7-W1 |
| 2219994 | Rubber bellows for shank Ø .375" | GU-2 |
| 2206230 | Range limiting caps, adjustable up to 9.52 mm / .375" | CS-123 |
| 2203163 | Brake attachment, dust cap mount (option), range limited to 6.35 mm / .250" for group 1 and to 12 mm / .500" for group 2-4 indicators | AT-81 |
| 2201801 | Adaptor for inductive probes for use on dial indicators (AGD) | AD-138 |
| 2201846 | Threaded bushing .625" long .500" OD with 5/16-32 internal thread | AD-62 |
| 2201854 | Split collet OD is 17.45 mm / .687"; requires 1/2-32 threaded hole | AD-87 |
| 2235806 | Tap 1/2 -32 | V-892 |
| 2205081 | Split bushing, for use with protective housing .375" stem hole X .687" OD | BU-111 |
| 2205127 | Split bushing with shoulder 8 mm stem hole X .375" OD | BU-197 |
| 2205195 | Split bushing, with counterbore, .375" stem hole x .500" OD | BU-80 |
| 2205200 | Split bushing without counterbore, .375" stem hole x .50" OD | BU-94 |
| 2204603 | Base for indicators with lug back | BA-1051 |



BU-80

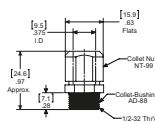

AD-87



AD-138



LR-48;LR-46;
LR-47;LR-50;
LR-68

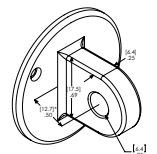

BK-1600;
BK-383;
BK-431;
BK-3

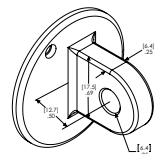

BK-1601;
BK-2168;
BK-545;
BK-4

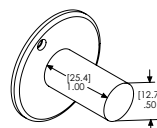

BK-1634

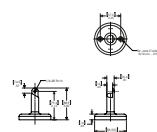

BA-1051

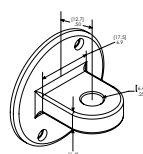

BK-19;
BK-400;
BK-109

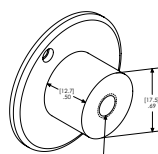

BK-1661;
BK-692;
BK-177;
BK-16

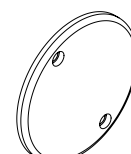

BK-1660

MarCator O1I / O3I / O6I / O8I

Dial indicator

FEATURES

- Unit construction and removable movement save repair/cleaning time and maintenance
- Hardened gears and stainless steel racks provide lasting protection against indicator failure due to shock or wear
- Jeweled bearings resist friction, add to longer indicator life
- Skeletonized, hobbled gears for more sensitive response, superior indicator accuracy with minimal hysteresis error
- Soft tinted dials (green - inch / yellow - metric) minimize eye strain
- Special steel alloy
- Balanced dial hand affords no shift, precise reading
- Controlled rack and pinion mesh eliminates slope for precise response and reading
- Smooth adjusting bezels for easy setup
- Positive pressure pull back spring requires less maintenance
- Compliance with ANSI/AGD dimensional and accuracy specifications
- These indicators are normally furnished with continuous dial (with R.C.) or + on right balance dial (w/o R.C.), lug back and .18" by .250" long contact
- Optional Dials: balanced dial with + on left; continuous clockwise; continuous counterclockwise (Order by part number and specify dial style desired)
- For other dial styles or special requirements - call Mahr

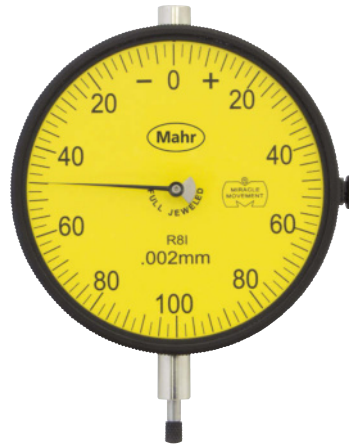

TECHNICAL DATA

| Order no. | Type | Measuring span | Readings | Figure on dial face | Rev. counter | Error limit, measuring range | Error limit | Standard | Scale diameter |
|-----------|--------|----------------|----------|---------------------|--------------|------------------------------|-------------|----------|----------------|
| | | mm | mm | | | μm | mm | | mm |
| 2011765 | O1I | 0.5 | 0.002 | 0-10-0 | | 8 | ± 0.004 | ANSI | 45 |
| 2011767 | O1I-RC | 0.5 | 0.002 | 0-20 | • | 8 | ± 0.004 | ANSI | 45 |
| 2011770 | O3I | 1.25 | 0.005 | 0-25-0 | | 10 | ± 0.005 | ANSI | 45 |
| 2011772 | O3I-RC | 1.25 | 0.005 | 0-50 | • | 10 | ± 0.005 | ANSI | 45 |
| 2011775 | O6I | 2.5 | 0.01 | 0-50-0 | | 20 | ± 0.010 | ANSI | 45 |
| 2011776 | O6I-RC | 2.5 | 0.01 | 0-100 | • | 20 | ± 0.010 | ANSI | 45 |
| 2011779 | O8I | 6.25 | 0.025 | 0-125-0 | | 50 | ± 0.025 | ANSI | 45 |
| 2011780 | O8I-RC | 6.25 | 0.025 | 0-250 | • | 50 | ± 0.025 | ANSI | 45 |

| Order no. | ANSI/AGD group | Range per turn | Dial color | Mounting shaft |
|-----------|----------------|----------------|------------|----------------|
| | | mm | | inch |
| 2011765 | 1 | 0.2 | Yellow | 0.375 |
| 2011767 | 1 | 0.2 | Yellow | 0.375 |
| 2011770 | 1 | 0.5 | Yellow | 0.375 |
| 2011772 | 1 | 0.5 | Yellow | 0.375 |
| 2011775 | 1 | 1 | Yellow | 0.375 |
| 2011776 | 1 | 1 | Yellow | 0.375 |
| 2011779 | 1 | 2.5 | Yellow | 0.375 |
| 2011780 | 1 | 2.5 | Yellow | 0.375 |

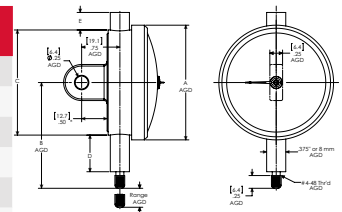

MarCator O11 / O31 / O61 / O81

Dial indicator

ACCESSORIES



BU-80

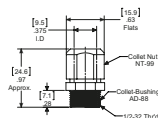

AD-87



AD-138



LR-48;LR-46;
LR-47;LR-50;
LR-68

| Order no. | Description | Type |
|-----------|---|-----------|
| 2203132 | Mounting bracket with adjusting knob | AT-115 |
| 2203155 | Mounting bracket with hex socket adjust | AT-27 |
| 2204756 | Vertical lug back, centered, 1/4" hole | BK-1600 |
| 2204757 | Vertical lug back, offset, 1/4" hole | BK-1601 |
| 2204758 | Adjustable back 1/4"-20 thread | BK-1633 |
| 2204759 | Post back 1/2" | BK-1634 |
| 2204760 | Flat back | BK-1660 |
| 2204761 | Screw type back 1/4-28 | BK-1661 |
| 2204771 | Horizontal lug back 1/4" hole | BK-19 |
| 2204811 | Rack back used on AT-27 and AT-115 | BK-92 |
| 2220156 | Tolerance hands with screw on bezel (option) | HD-59 |
| 2220542 | Lifting lever, left hand | LR-46 |
| 2220543 | Lifting lever, right hand | LR-47 |
| 2220539 | OX-bow lifting lever | LR-40 |
| 22203183 | Brake attachment (option) | AT-A-7-W1 |
| 2219994 | Rubber bellows for shank Ø .375" | GU-2 |
| 2206230 | Range limiting caps, adjustable up to 9.52 mm / .375" | CS-123 |
| 2203163 | Brake attachment, dust cap mount (option), range limited to 6.35 mm / .250" for group 1 and to 12 mm / .500" for group 2-4 indicators | AT-81 |
| 2201801 | Adaptor for inductive probes for use on dial indicators (AGD) | AD-138 |
| 2201846 | Threaded bushing .625" long .500" OD with 5/16-32 internal thread | AD-62 |
| 2201854 | Split collet OD is 17.45 mm / .687"; requires 1/2-32 threaded hole | AD-87 |
| 2235806 | Tap 1/2 -32 | V-892 |
| 2205081 | Split bushing, for use with protective housing .375" stem hole X .687" OD | BU-111 |
| 2205127 | Split bushing with shoulder 8 mm stem hole X .375" OD | BU-197 |
| 2205195 | Split bushing, with counterbore, .375" stem hole x .500" OD | BU-80 |
| 2205200 | Split bushing without counterbore, .375" stem hole x .50" OD | BU-94 |
| 2204603 | Base for indicators with lug back | BA-1051 |

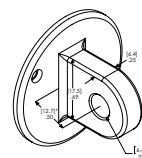

BK-1600;
BK-383;
BK-431;
BK-3

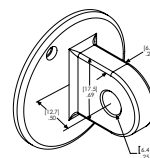

BK-1601;
BK-2168;
BK-545;
BK-4

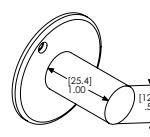

BK-1634

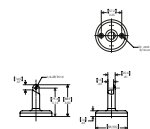

BA-1051

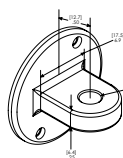

BK-19;
BK-400;
BK-109

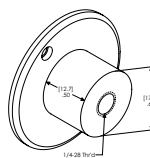

BK-1661;
BK-692;
BK-177;
BK-16

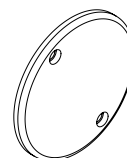

BK-1660

FEATURES

- Unit construction and removable movement save repair/cleaning time and maintenance
- Hardened gears and stainless steel racks provide lasting protection against indicator failure due to shock or wear
- Jeweled bearings resist friction, add to longer indicator life
- Skeletonized, hobbled gears for more sensitive response, superior indicator accuracy with minimal hysteresis error
- Soft tinted dials (green - inch / yellow - metric) minimize eye strain
- Special steel alloy
- Balanced dial hand affords no shift, precise reading
- Controlled rack and pinion mesh eliminates slope for precise response and reading
- Smooth adjusting bezels for easy setup
- Positive pressure pull back spring requires less maintenance
- Compliance with ANSI/AGD dimensional and accuracy specifications
- These indicators are normally furnished with continuous dial (with R.C.) or + on right balance dial (w/o R.C.), lug back and .18" by .250" long contact
- **Optional dials:** balanced dial with + on left; continuous clockwise; continuous counterclockwise. (Order by part number and specify dial style desired)
- For other dial styles or special requirements - call Mahr



TECHNICAL DATA

| Order no. | Type | Measuring span | Scale graduation value | Figure on dial face | Rev. counter | Range per turn | Error limit, measuring range | Error limit | Standard | ANSI/AGD Group |
|-----------|----------|----------------|------------------------|---------------------|--------------|----------------|------------------------------|-------------|----------|----------------|
| 2011049 | 28IN-RC | .250" | .001" | 0-100 | • | .100" | 0.002 | ±.001" | ANSI | 2 |
| 2011157 | C1/2K | .010" | .00005" | 0-2-0 | | .004" | 0.0002 | ±.0001" | ANSI | 2 |
| 2011158 | C1/2K-RC | .010" | .00005" | 0-4 | • | .004" | 0.0002 | ±.0001" | ANSI | 2 |
| 2011161 | C1K | .020" | .0001" | 0-4-0 | | .008" | 0.0002 | ±.0001" | ANSI | 2 |
| 2011162 | C1K-RC | .020" | .0001" | 0-8 | • | .008" | 0.0002 | ±.0001" | ANSI | 2 |
| 2014761 | 22IN-RC | .025" | .0001" | 0-10 | • | .010" | 0.0002 | ±.0001" | ANSI | 2 |
| 2014791 | 22QN-RC | .025" | .00025" | 0-10 | • | .010" | 0.0005 | ±.00025" | ANSI | 2 |
| 2014808 | 23K-RC | .050" | .00025" | 0-20 | • | .020" | 0.0005 | ±.00025" | ANSI | 2 |
| 2014809 | 23W-RC | .050" | .001" | 0-20 | • | .020" | 0.002 | ±.001" | ANSI | 2 |
| 2014810 | 23Q-RC | .050" | .0005" | 0-20 | • | .020" | 0.001 | ±.0005" | ANSI | 2 |
| 2014811 | 25M-RC | .075" | .0005" | 0-30 | • | .030" | 0.001 | ±.0005" | ANSI | 2 |
| 2014812 | 26K-RC | .100" | .0005" | 0-40 | • | .040" | 0.001 | ±.0005" | ANSI | 2 |
| 2014813 | 26Q-RC | .100" | .001" | 0-40 | • | .040" | 0.002 | ±.001" | ANSI | 2 |
| 2014814 | 27I-RC | .125" | .0005" | 0-50 | • | .050" | 0.001 | ±.0005" | ANSI | 2 |
| 2014815 | 27O-RC | .125" | .001" | 0-50 | • | .050" | 0.002 | ±.001" | ANSI | 2 |
| 2015781 | 22I | .025" | .0001" | 0-5-0 | | .010" | 0.0002 | ±.0001" | ANSI | 2 |
| 2015782 | 22QN | .025" | .00025" | 0-5-0 | | .010" | 0.0005 | ±.00025" | ANSI | 2 |
| 2015783 | 23K | .050" | .00025" | 0-10-0 | | .020" | 0.0005 | ±.00025" | ANSI | 2 |
| 2015784 | 23Q | .050" | .0005" | 0-10-0 | | .020" | 0.001 | ±.0005" | ANSI | 2 |
| 2015785 | 23W | .050" | .001" | 0-10-0 | | .020" | 0.002 | ±.001" | ANSI | 2 |
| 2015786 | 25M | .075" | .0005" | 0-15-0 | | .030" | 0.001 | ±.0005" | ANSI | 2 |
| 2015787 | 26K | .100" | .0005" | 0-20-0 | | .040" | 0.001 | ±.0005" | ANSI | 2 |
| 2015789 | 26Q | .100" | .001" | 0-20-0 | | .040" | 0.002 | ±.001" | ANSI | 2 |
| 2015790 | 27I | .125" | .0005" | 0-25-0 | | .050" | 0.001 | ±.0005" | ANSI | 2 |
| 2015791 | 27O | .125" | .001" | 0-25-0 | | .050" | 0.002 | ±.001" | ANSI | 2 |
| 2015792 | 28IN | .250" | .001" | 0-50-0 | | .100" | 0.002 | ±.001" | ANSI | 2 |

| Order no. | Scale diameter | Range per turn | Dial color | Mounting shaft | Order no. | Scale diameter | Range per turn | Dial color | Mounting shaft |
|-----------|----------------|----------------|------------|----------------|-----------|----------------|----------------|------------|----------------|
| | inch | inch | | inch | | inch | inch | | inch |
| 2011049 | 2.25 | 0.1000 | Green | 0.375 | 2014814 | 2.25 | 0.0500 | Green | 0.375 |
| 2011157 | 2.25 | 0.0040 | Green | 0.375 | 2014815 | 2.25 | 0.0500 | Green | 0.375 |
| 2011158 | 2.25 | 0.0040 | Green | 0.375 | 2015781 | 2.25 | 0.0100 | Green | 0.375 |
| 2011161 | 2.25 | 0.0080 | Green | 0.375 | 2015782 | 2.25 | 0.0100 | Green | 0.375 |
| 2011162 | 2.25 | 0.0080 | Green | 0.375 | 2015783 | 2.25 | 0.0200 | Green | 0.375 |
| 2014761 | 2.25 | 0.0100 | Green | 0.375 | 2015784 | 2.25 | 0.0200 | Green | 0.375 |
| 2014791 | 2.25 | 0.0100 | Green | 0.375 | 2015785 | 2.25 | 0.0200 | Green | 0.375 |
| 2014808 | 2.25 | 0.0200 | Green | 0.375 | 2015786 | 2.25 | 0.0300 | Green | 0.375 |
| 2014809 | 2.25 | 0.0200 | Green | 0.375 | 2015787 | 2.25 | 0.0400 | Green | 0.375 |
| 2014810 | 2.25 | 0.0200 | Green | 0.375 | 2015789 | 2.25 | 0.0400 | Green | 0.375 |
| 2014811 | 2.25 | 0.0300 | Green | 0.375 | 2015790 | 2.25 | 0.0500 | Green | 0.375 |
| 2014812 | 2.25 | 0.0400 | Green | 0.375 | 2015791 | 2.25 | 0.0500 | Green | 0.375 |
| 2014813 | 2.25 | 0.0400 | Green | 0.375 | 2015792 | 2.25 | 0.1000 | Green | 0.375 |

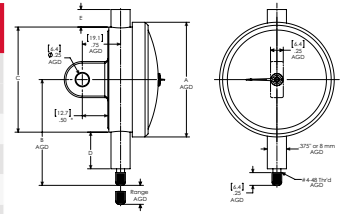

ACCESSORIES

| Order no. | Description | Type |
|-----------|---|-----------|
| 2014804 | Magnetic maximum hand with snap-on bezel (option) | 2014804 |
| 2203133 | Mounting bracket with adjusting knob for AGD 2 | AT-116 |
| 2204772 | Post back 1/2" Ø | BK-2093 |
| 2204773 | Vertical lug, offset 1/4" hole | BK-2168 |
| 2204780 | Vertical lug back, centered 1/4" hole | BK-383 |
| 2204782 | Horizontal lug back, centered, 1/4" hole | BK-400 |
| 2204786 | Flat back for AGD 2 | BK-470 |
| 2204790 | Adjustable back 1/4-20 thread | BK-531 |
| 2204802 | Screw type back 1/4-28 | BK-692 |
| 2204812 | Rack back used on AT-116 and AT-28 | BK-93 |
| 2205222 | Tolerance hands with snap-on bezel (option) | BZ-2503 |
| 2220154 | Tolerance hands with screw-on bezel (option) | HD-57 |
| 2220177 | Protective housing for AGD 2 models with ranges up to 6.35 mm/ .250" | HG-100 |
| 2220178 | Protective housing for AGD 2 models with ranges up to 25 mm/ 1" | HG-101 |
| 2220544 | Lifting lever to lift probe manually (left) | LR-48 |
| 2220545 | Lifting lever to lift probe manually (right) | LR-49 |
| 2220539 | OX-bow lifting lever | LR-40 |
| 2203184 | Brake attachment (option) | AT-A-7-W2 |
| 2203163 | Brake attachment, dust cap mount (option), range limited to 6.35 mm/ .250" for group 1 and to 12 mm/ .500" for group 2-4 indicators | AT-81 |
| 2219994 | Rubber bellows for shank Ø .375" | GU-2 |
| 2201801 | Adaptor for inductive probes for use on dial indicators (AGD) | AD-138 |
| 2201843 | Adaptor bushing 0.275" ID to 0.375" OD | AD-58 |
| 2201846 | Threaded bushing .625" long .500" OD with 5/16-32 internal thread | AD-62 |
| 2201854 | Split collet OD is 17.45 mm/ .687"; requires 1/2-32 threaded hole | AD-87 |
| 2235806 | Tap 1/2 -32 | V-892 |
| 2205081 | Split bushing, for use with protective housing .375" stem hole X .687" OD | BU-111 |
| 2205195 | Split bushing, with counterbore, .375" stem hole x .500" OD | BU-80 |
| 2205200 | Split bushing without counterbore, .375" stem hole x .50" OD | BU-94 |
| 2204603 | Base for indicators with lug back | BA-1051 |
| 2206230 | Range limiting caps, adjustable up to 9.52 mm / .375" | CS-123 |

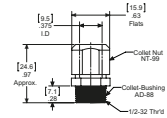

AD-87



AD-138



LR-48; LR-46;
LR-47; LR-50; LR-68



HD-57; HD-53

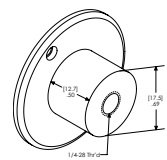

BK-1661; BK-692;
BK-177; BK-16



2011341; 2014804

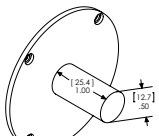

BK-2093; BK-664;
BK-17

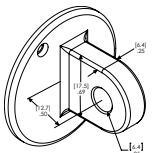

BK-1601; BK-2168;
BK-545; BK-4



HG-100; HG-101

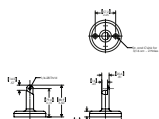

BA-1051



BU-80

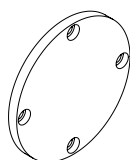

BK-32; BK-470;
BK-473; BK-5

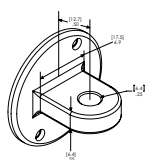

BK-19; BK-400;
BK-109

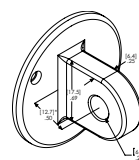

BK-1600; BK-383;
BK-431; BK-3

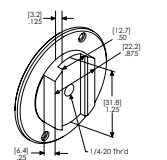

BK-531; BK-10;
BK-18

MarCator

Dial indicator

FEATURES

- Unit construction and removable movement save repair/cleaning time and maintenance
- Hardened gears and stainless steel racks provide lasting protection against indicator failure due to shock or wear
- Jeweled bearings resist friction, add to longer indicator life
- Skeletonized, hobbled gears for more sensitive response, superior indicator accuracy with minimal hysteresis error
- Soft tinted dials (green - inch / yellow - metric) minimize eye strain
- Special steel alloy
- Balanced dial hand affords no shift, precise reading
- Controlled rack and pinion mesh eliminates slope for precise response and reading
- Smooth adjusting bezels for easy setup
- Positive pressure pullback spring requires less maintenance
- Compliance with ANSI/AGD dimensional and accuracy specifications
- These indicators are normally furnished with continuous dial (with R.C.) or + on right balance dial (w/o R.C.), lug back and .18" by .250" long contact
- **Optional dials:** balanced dial with + on left; continuous clockwise; continuous counterclockwise. (Order by part number and specify dial style desired)
- For other dial styles or special requirements - call Mahr



TECHNICAL DATA

| Order no. | Type | Measuring span | Readings | Figure on dial face | Rev. counter | Error limit, measuring range | Error limit | Standard | Scale diameter |
|-----------|----------|----------------|----------|---------------------|--------------|------------------------------|-------------|----------|----------------|
| | | mm | mm | | | μm | mm | | mm |
| 2011810 | P1/2I | 0.25 | 0.001 | 0-5-0 | | 4 | ± 0.002 | ANSI | 57 |
| 2011812 | P1/2I-RC | 0.25 | 0.001 | 0-10 | • | 4 | ± 0.002 | ANSI | 57 |
| 2011815 | P1I | 0.5 | 0.002 | 0-10-0 | | 8 | ± 0.004 | ANSI | 57 |
| 2011817 | P1I-RC | 0.5 | 0.002 | 0-20 | • | 8 | ± 0.004 | ANSI | 57 |
| 2014817 | 23IM-RC | 1.25 | 0.005 | 0-50 | • | 10 | ± 0.005 | ANSI | 57 |
| 2014818 | 26IM-RC | 2.5 | 0.01 | 0-100 | • | 20 | ± 0.010 | ANSI | 57 |
| 2014819 | 28IM-RC | 5 | 0.02 | 0-200 | • | 40 | ± 0.020 | ANSI | 57 |
| 2015793 | 23I | 1.25 | 0.005 | 0-25-0 | | 10 | ± 0.005 | ANSI | 57 |
| 2015794 | 26I | 2.5 | 0.01 | 0-50-0 | | 20 | ± 0.010 | ANSI | 57 |
| 2015795 | 28IM | 5 | 0.02 | 0-100-0 | | 40 | ± 0.020 | ANSI | 57 |

| Order no. | ANSI/AGD group | Range per turn | Dial color | Mounting shaft |
|-----------|----------------|----------------|------------|----------------|
| | | mm | | inch |
| 2011810 | 2 | 0.1 | Yellow | 0.375 |
| 2011812 | 2 | 0.1 | Yellow | 0.375 |
| 2011815 | 2 | 0.2 | Yellow | 0.375 |
| 2011817 | 2 | 0.2 | Yellow | 0.375 |
| 2014817 | 2 | 0.5 | Yellow | 0.375 |
| 2014818 | 2 | 1 | Yellow | 0.375 |
| 2014819 | 2 | 2 | Yellow | 0.375 |
| 2015793 | 2 | 0.5 | Yellow | 0.375 |
| 2015794 | 2 | 1 | Yellow | 0.375 |
| 2015795 | 2 | 2 | Yellow | 0.375 |

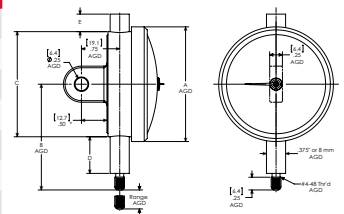

ACCESSORIES

| Order no. | Description | Type |
|-----------|---|-----------|
| 2014804 | Magnetic maximum hand with snap-on bezel (option) | 2014804 |
| 2203133 | Mounting bracket with adjusting knob for AGD 2 | AT-116 |
| 2204772 | Post back 1/2" Ø | BK-2093 |
| 2204773 | Vertical lug, offset 1/4" hole | BK-2168 |
| 2204780 | Vertical lug back, centered 1/4" hole | BK-383 |
| 2204782 | Horizontal lug back, centered, 1/4" hole | BK-400 |
| 2204786 | Flat back for AGD 2 | BK-470 |
| 2204790 | Adjustable back 1/4-20 thread | BK-531 |
| 2204802 | Screw type back 1/4-28 | BK-692 |
| 2204812 | Rack back used on AT-116 and AT-28 | BK-93 |
| 2205222 | Tolerance hands with snap-on bezel (option) | BZ-2503 |
| 2220154 | Tolerance hands with screw-on bezel (option) | HD-57 |
| 2220177 | Protective housing for AGD 2 models with ranges up to 6.35 mm/ .250" | HG-100 |
| 2220178 | Protective housing for AGD 2 models with ranges up to 25 mm/ 1" | HG-101 |
| 2220544 | Lifting lever to lift probe manually (left) | LR-48 |
| 2220545 | Lifting lever to lift probe manually (right) | LR-49 |
| 2220539 | OX-bow lifting lever | LR-40 |
| 2203184 | Brake attachment (option) | AT-A-7-W2 |
| 2203163 | Brake attachment, dust cap mount (option), range limited to 6.35 mm/ .250" for group 1 and to 12 mm/ .500" for group 2-4 indicators | AT-81 |
| 2219994 | Rubber bellows for shank Ø .375" | GU-2 |
| 2201801 | Adaptor for inductive probes for use on dial indicators (AGD) | AD-138 |
| 2201843 | Adaptor bushing 0.275" ID to 0.375" OD | AD-58 |
| 2201846 | Threaded bushing .625" long .500" OD with 5/16-32 internal thread | AD-62 |
| 2201854 | Split collet OD is 17.45 mm/ .687"; requires 1/2-32 threaded hole | AD-87 |
| 2235806 | Tap 1/2 -32 | V-892 |
| 2205081 | Split bushing, for use with protective housing .375" stem hole X .687" OD | BU-111 |
| 2205195 | Split bushing, with counterbore, .375" stem hole x .500" OD | BU-80 |
| 2205200 | Split bushing without counterbore, .375" stem hole x .50" OD | BU-94 |
| 2204603 | Base for indicators with lug back | BA-1051 |
| 2206230 | Range limiting caps, adjustable up to 9.52 mm / .375" | CS-123 |



2011341; 2014804

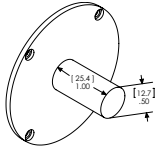

BK-2093; BK-664; BK-17

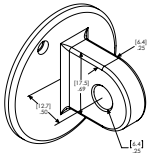

BK-1601; BK-2168; BK-545; BK-4



HG-100; HG-101

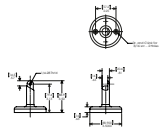

BA-1051



BU-80

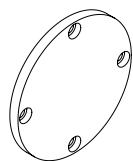

BK-32; BK-470; BK-473; BK-5

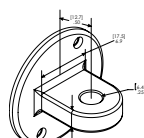

BK-19; BK-400; BK-109

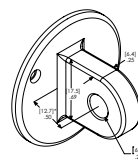

BK-1600; BK-383; BK-431; BK-3

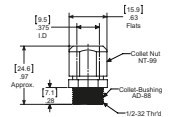

AD-87



AD-138



LR-48; LR-46; LR-47; LR-50; LR-68



HD-57; HD-53

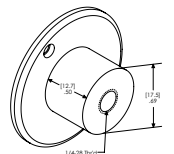

BK-1661; BK-692; BK-177; BK-16

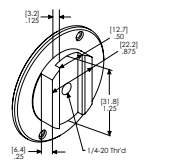

BK-531; BK-10; BK-18

MarCator

Dial indicator

FEATURES

- Unit construction and removable movement save repair/cleaning time and maintenance
- Hardened gears and stainless steel racks provide lasting protection against indicator failure due to shock or wear
- Jeweled bearings resist friction, add to longer indicator life
- Skeletonized, hobbled gears for more sensitive response, superior indicator accuracy with minimal hysteresis error
- Soft tinted dials (green - inch / yellow - metric) minimize eye strain
- Special steel alloy
- Balanced dial hand affords no shift, precise reading
- Controlled rack and pinion mesh eliminates slope for precise response and reading
- Smooth adjusting bezels for easy setup
- Positive pressure pull back spring requires less maintenance
- Compliance with ANSI/AGD dimensional and accuracy specifications
- These indicators are normally furnished with continuous dial (with R.C.) or + on right balance dial (w/o R.C.), lug back and .18" by .250" long contact
- **Optional Dials:** balanced dial with + on left; continuous clockwise; continuous counterclockwise. (Order by part number and specify dial style desired)
- For other dial styles or special requirements - call Mahr



TECHNICAL DATA

| Order no. | Type | Measuring span | Scale graduation value | Figure on dial face | Rev. counter | Range per turn | Error limit, measuring range | Error limit | Standard | ANSI/AGD group |
|-----------|--------|----------------|------------------------|---------------------|--------------|----------------|------------------------------|-------------|----------|----------------|
| | | inch | inch | | | inch | inch | inch | | |
| 2011050 | 32I | .025" | .0001" | 0-5-0 | | .010" | 0.0002 | ±.0001" | ANSI | 3 |
| 2011051 | 32I-RC | .025" | .0001" | 0-10 | • | .010" | 0.0002 | ±.0001" | ANSI | 3 |
| 2011054 | 32Q | .025" | .00025" | 0-5-0 | | .010" | 0.0005 | ±.00025" | ANSI | 3 |
| 2011055 | 32Q-RC | .025" | .00025" | 0-10 | • | .010" | 0.0005 | ±.00025" | ANSI | 3 |
| 2011226 | D1K | .020" | .0001" | 0-4-0 | | .008" | 0.0002 | ±.0001" | ANSI | 3 |
| 2011227 | D1K-RC | .020" | .0001" | 0-8 | • | .008" | 0.0002 | ±.0001" | ANSI | 3 |
| 2011230 | D3K | .050" | .00025" | 0-10-0 | | .020" | 0.0005 | ±.00025" | ANSI | 3 |
| 2011231 | D3K-RC | .050" | .00025" | 0-20 | • | .020" | 0.0005 | ±.00025" | ANSI | 3 |
| 2011234 | D3Q | .050" | .0005" | 0-10-0 | | .020" | 0.001 | ±.0005" | ANSI | 3 |
| 2011235 | D3Q-RC | .050" | .0005" | 0-20 | • | .020" | 0.001 | ±.0005" | ANSI | 3 |
| 2011238 | D3W | .050" | .001" | 0-10-0 | | .020" | 0.002 | ±.001" | ANSI | 3 |
| 2011239 | D3W-RC | .050" | .001" | 0-20 | • | .020" | 0.002 | ±.001" | ANSI | 3 |
| 2011242 | D5G | .075" | .00025" | 0-15-0 | | .030" | 0.0005 | ±.00025" | ANSI | 3 |
| 2011243 | D5G-RC | .075" | .00025" | 0-30 | • | .030" | 0.0005 | ±.00025" | ANSI | 3 |
| 2011246 | D5M | .075" | .0005" | 0-15-0 | | .030" | 0.001 | ±.0005" | ANSI | 3 |
| 2011247 | D5M-RC | .075" | .0005" | 0-30 | • | .030" | 0.001 | ±.0005" | ANSI | 3 |
| 2011250 | D6K | .100" | .0005" | 0-20-0 | | .040" | 0.001 | ±.0005" | ANSI | 3 |
| 2011251 | D6K-RC | .100" | .0005" | 0-40 | • | .040" | 0.001 | ±.0005" | ANSI | 3 |
| 2011254 | D6Q | .100" | .001" | 0-20-0 | | .040" | 0.002 | ±.001" | ANSI | 3 |
| 2011255 | D6Q-RC | .100" | .001" | 0-40 | • | .040" | 0.002 | ±.001" | ANSI | 3 |
| 2011258 | D7I | .125" | .0005" | 0-25-0 | | .050" | 0.001 | ±.0005" | ANSI | 3 |
| 2011259 | D7I-RC | .125" | .0005" | 0-50 | • | .050" | 0.001 | ±.0005" | ANSI | 3 |
| 2011262 | D7O | .125" | .001" | 0-25-0 | | .050" | 0.002 | ±.001" | ANSI | 3 |
| 2011263 | D7O-RC | .125" | .001" | 0-50 | • | .050" | 0.002 | ±.001" | ANSI | 3 |
| 2011266 | D8I | .250" | .001" | 0-50-0 | | .100" | 0.002 | ±.001" | ANSI | 3 |
| 2011267 | D8I-RC | .250" | .001" | 0-100 | • | .100" | 0.002 | ±.001" | ANSI | 3 |

MarCator

Dial indicator

| Order no. | Scale diameter | Range per turn | Dial color | Mounting shaft | Order no. | Scale diameter | Range per turn | Dial color | Mounting shaft |
|-----------|----------------|----------------|------------|----------------|-----------|----------------|----------------|------------|----------------|
| | inch | inch | | inch | | inch | inch | | inch |
| 2011050 | 2.75 | 0.0100 | Green | 0.375 | 2011243 | 2.75 | 0.0300 | Green | 0.375 |
| 2011051 | 2.75 | 0.0100 | Green | 0.375 | 2011246 | 2.75 | 0.0300 | Green | 0.375 |
| 2011054 | 2.75 | 0.0100 | Green | 0.375 | 2011247 | 2.75 | 0.0300 | Green | 0.375 |
| 2011055 | 2.75 | 0.0100 | Green | 0.375 | 2011250 | 2.75 | 0.0400 | Green | 0.375 |
| 2011226 | 2.75 | 0.0080 | Green | 0.375 | 2011251 | 2.75 | 0.0400 | Green | 0.375 |
| 2011227 | 2.75 | 0.0080 | Green | 0.375 | 2011254 | 2.75 | 0.0400 | Green | 0.375 |
| 2011230 | 2.75 | 0.0200 | Green | 0.375 | 2011255 | 2.75 | 0.0400 | Green | 0.375 |
| 2011231 | 2.75 | 0.0200 | Green | 0.375 | 2011258 | 2.75 | 0.0500 | Green | 0.375 |
| 2011234 | 2.75 | 0.0200 | Green | 0.375 | 2011259 | 2.75 | 0.0500 | Green | 0.375 |
| 2011235 | 2.75 | 0.0200 | Green | 0.375 | 2011262 | 2.75 | 0.0500 | Green | 0.375 |
| 2011238 | 2.75 | 0.0200 | Green | 0.375 | 2011263 | 2.75 | 0.0500 | Green | 0.375 |
| 2011239 | 2.75 | 0.0200 | Green | 0.375 | 2011266 | 2.75 | 0.1000 | Green | 0.375 |
| 2011242 | 2.75 | 0.0300 | Green | 0.375 | 2011267 | 2.75 | 0.1000 | Green | 0.375 |

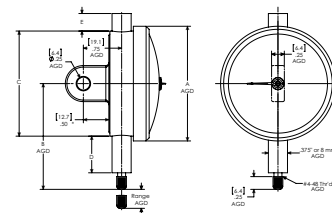

ACCESSORIES

| Order no. | Description | Type |
|-----------|---|-----------|
| 2011341 | Magnetic maximum hand (option) | 2011341 |
| 2204730 | Adjustable back with 1/4-20 thread | BK-10 |
| 2204734 | Horizontal lug back, centered | BK-109 |
| 2204763 | Screw type back 1/4-28 | BK-177 |
| 2204784 | Vertical lug back, centered | BK-431 |
| 2204787 | Flat back | BK-473 |
| 2204791 | Vertical lug back, offset | BK-545 |
| 2204799 | Post back 1/2" Ø | BK-664 |
| 2220546 | Lifting lever to lift probe manually (left) | LR-50 |
| 2220547 | Lifting lever to lift probe manually (right) | LR-51 |
| 2220539 | OX-bow lifting lever | LR-40 |
| 2203185 | Brake attachment (option) | AT-A-7-W3 |
| 2203163 | Brake attachment, dust cap mount (option), range limited to 6.35 mm/ .250" for group 1 and to 12 mm/ .500" for group 2-4 indicators | AT-81 |
| 2219994 | Rubber bellows for shank Ø .375" | GU-2 |
| 2206230 | Range limiting caps, adjustable up to 9.52 mm / .375" | CS-123 |
| 2201801 | Adaptor for inductive probes for use on dial indicators (AGD) | AD-138 |
| 2201846 | Threaded bushing .625" long .500" OD with 5/16-32 internal thread | AD-62 |
| 2201854 | Split collet OD is 17.45 mm/ .687"; requires 1/2-32 threaded hole | AD-87 |
| 2235806 | Tap 1/2 -32 | V-892 |
| 2205081 | Split bushing, for use with protective housing .375" stem hole X .687" OD | BU-111 |
| 2205127 | Split bushing with shoulder 8 mm stem hole X .375" OD | BU-197 |
| 2205195 | Split bushing, with counterbore, .375" stem hole x .500" OD | BU-80 |
| 2205200 | Split bushing without counterbore, .375" stem hole x .50" OD | BU-94 |
| 2204603 | Base for indicators with lug back | BA-1051 |



2011341; 2014804

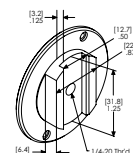

BK-531; BK-10; BK-18

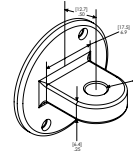

BK-19; BK-400; BK-109



AD-138

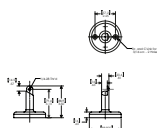

BA-1051



BU-80

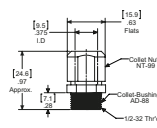

AD-87



LR-48; LR-46; LR-47; LR-50; LR-68

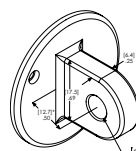

BK-1600; BK-383; BK-431; BK-3

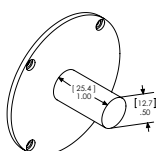

BK-2093; BK-664; BK-17

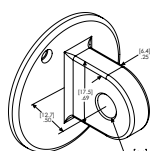

BK-1601; BK-2168; BK-545; BK-4

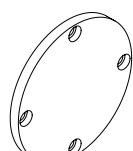

BK-32; BK-470; BK-473; BK-5

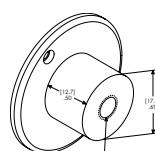

BK-1661; BK-692; BK-177; BK-16

MarCator Q1I / Q3I / Q6I / Q8I

Dial indicator

FEATURES

- Unit construction and removable movement save repair/cleaning time and maintenance
- Hardened gears and stainless steel racks provide lasting protection against indicator failure due to shock or wear
- Jeweled bearings resist friction, add to longer indicator life
- Skeletonized, hobbled gears for more sensitive response, superior indicator accuracy with minimal hysteresis error
- Soft tinted dials (green - inch / yellow - metric) minimize eye strain
- Special steel alloy
- Balanced dial hand affords no shift, precise reading
- Controlled rack and pinion mesh eliminates slope for precise response and reading
- Smooth adjusting bezels for easy setup
- Positive pressure pull back spring requires less maintenance
- Compliance with ANSI/AGD dimensional and accuracy specifications
- These indicators are normally furnished with continuous dial (with R.C.) or + on right balance dial (w/o R.C.), lug back and .18" by .250" long contact
- **Optional dials:** balanced dial with + on left; continuous clockwise; continuous counterclockwise. (Order by part number and specify dial style desired)
- For other dial styles or special requirements - call Mahr

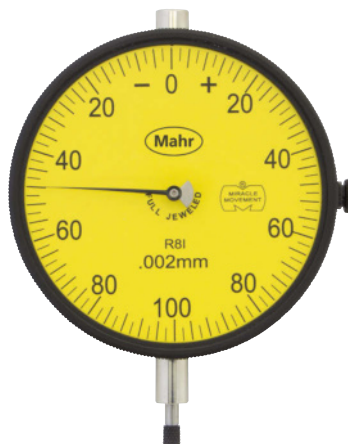

TECHNICAL DATA

| Order no. | Type | Measuring span | Readings | Figure on dial face | Rev. counter | Error limit, measuring range | Error limit | Standard | Scale diameter |
|-----------|--------|----------------|----------|---------------------|--------------|------------------------------|-------------|----------|----------------|
| | | mm | mm | | | µm | mm | | mm |
| 2011867 | Q1I | 0.5 | 0.002 | 0-10-0 | | 8 | ± 0.004 | ANSI | 70 |
| 2011868 | Q1I-RC | 0.5 | 0.002 | 0-20 | • | 8 | ± 0.004 | ANSI | 70 |
| 2011871 | Q3I | 1.25 | 0.005 | 0-25-0 | | 10 | ± 0.005 | ANSI | 70 |
| 2011872 | Q3I-RC | 1.25 | 0.005 | 0-50 | • | 10 | ± 0.005 | ANSI | 70 |
| 2011875 | Q6I | 2.5 | 0.01 | 0-50-0 | | 20 | ± 0.010 | ANSI | 70 |
| 2011876 | Q6I-RC | 2.5 | 0.01 | 0-100 | • | 20 | ± 0.010 | ANSI | 70 |
| 2011879 | Q8I | 5 | 0.02 | 0-100-0 | | 40 | ± 0.020 | ANSI | 70 |
| 2011880 | Q8I-RC | 5 | 0.02 | 0-200 | • | 40 | ± 0.020 | ANSI | 70 |

| Order no. | ANSI/AGD group | Range per turn | Dial color | Mounting shaft |
|-----------|----------------|----------------|------------|----------------|
| | | mm | | inch |
| 2011867 | 3 | 0.2 | Yellow | 0.375 |
| 2011868 | 3 | 0.2 | Yellow | 0.375 |
| 2011871 | 3 | 0.5 | Yellow | 0.375 |
| 2011872 | 3 | 0.5 | Yellow | 0.375 |
| 2011875 | 3 | 1 | Yellow | 0.375 |
| 2011876 | 3 | 1 | Yellow | 0.375 |
| 2011879 | 3 | 2 | Yellow | 0.375 |
| 2011880 | 3 | 2 | Yellow | 0.375 |

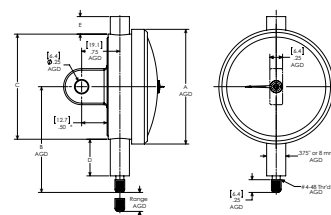

MarCator Q1I / Q3I / Q6I / Q8I

Dial indicator

ACCESSORIES

| Order no. | Description | Type |
|-----------|---|-----------|
| 2011341 | Magnetic maximum hand (option) | 2011341 |
| 2204730 | Adjustable back with 1/4-20 thread | BK-10 |
| 2204734 | Horizontal lug back, Centered | BK-109 |
| 2204763 | Screw type back 1/4-28 | BK-177 |
| 2204784 | Vertical lug back, centered | BK-431 |
| 2204787 | Flat back | BK-473 |
| 2204791 | Vertical lug back, offset | BK-545 |
| 2204799 | Post back 1/2" Ø | BK-664 |
| 2220546 | Lifting lever to lift probe manually (left) | LR-50 |
| 2220547 | Lifting lever to lift probe manually (right) | LR-51 |
| 2220539 | OX-bow lifting lever | LR-40 |
| 2203185 | Brake attachment (option) | AT-A-7-W3 |
| 2203163 | Brake attachment, dust cap mount (option), range limited to 6.35 mm / .250" for group 1 and to 12 mm / .500" for group 2-4 indicators | AT-81 |
| 2219994 | Rubber bellows for shank Ø .375" | GU-2 |
| 2206230 | Range limiting caps, adjustable up to 9.52 mm / .375" | CS-123 |
| 2201801 | Adaptor for inductive probes for use on dial indicators (AGD) | AD-138 |
| 2201846 | Threaded bushing .625" long .500" OD with 5/16-32 internal thread | AD-62 |
| 2201854 | Split collet OD is 17.45 mm / .687"; requires 1/2-32 threaded hole | AD-87 |
| 2235806 | Tap 1/2 -32 | V-892 |
| 2205081 | Split bushing, for use with protective housing .375" stem hole X .687" OD | BU-111 |
| 2205127 | Split bushing with shoulder 8 mm stem hole X .375" OD | BU-197 |
| 2205195 | Split bushing, with counterbore, .375" stem hole x .500" OD | BU-80 |
| 2205200 | Split bushing without counterbore, .375" stem hole x .50" OD | BU-94 |
| 2204603 | Base for indicators with lug back | BA-1051 |



2011341; 2014804

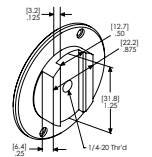

BK-531; BK-10; BK-18

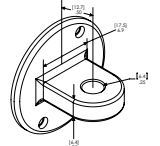

BK-19; BK-40; BK-109



AD-138

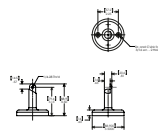

BA-1051



BU-80

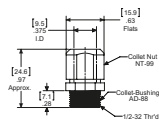

AD-87



LR-48; LR-46; LR-47; LR-50; LR-68

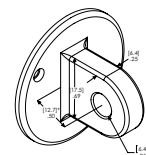

BK-1600; BK-383; BK-431; BK-3

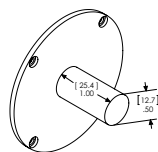

BK-2093; BK-664; BK-17

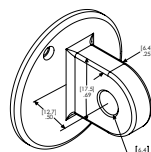

BK-1601; BK-2168; BK-545; BK-4

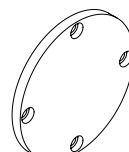

BK-32; BK-470; BK-473; BK-5

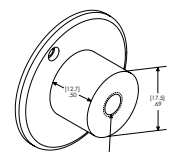

BK-1661; BK-692; BK-177; BK-16

MarCator D8IS / D8IT / 28ISN / 28IQN / 29I

Dial indicator

FEATURES

- Unit construction and removable movement save repair/cleaning time and maintenance
- Hardened gears and stainless steel racks provide lasting protection against indicator failure due to shock or wear
- Jeweled bearings resist friction, add to longer indicator life
- Skeletonized, hobbled gears for more sensitive response, superior indicator accuracy with minimal hysteresis error
- Soft tinted dials (green - inch / yellow - metric) minimize eye strain
- Special steel alloy
- Balanced dial hand affords no shift, precise reading
- Controlled rack and pinion mesh eliminates slope for precise response and reading
- Smooth adjusting bezels for easy setup
- Positive pressure pullback spring requires less maintenance
- Normally furnished: continuous clockwise dial; centered vertical lug back; regular contact point, .18" radiused, .250" long
- **Long range models:** include (1) revolution counter (except C9I without revolution counter).
- **Extra long range models:** include (2) revolution counters
- For other dial styles or special requirements - call Mahr



TECHNICAL DATA

| Order no. | Type | Measuring span | Scale graduation value | Figure on dial face | Rev. counter | Range per turn | Error limit, measuring range | Error limit | Standard |
|-----------|-------|----------------|------------------------|---------------------|--------------|----------------|------------------------------|--------------------------------|----------|
| | | inch | inch | | | inch | inch | inch | |
| 2011270 | D8IS | 1.000" | .001" | 0-100 | • | .100" | 0.002 | ± .001" | ANSI |
| 2011272 | D8IT | 2.000" | .001" | 0-100 | • | .100" | 0.002 | ± .001" for first 1" of travel | ANSI |
| 2014698 | 28ISN | 1.000" | .001" | 0-100 | • | .100" | 0.002 | ± .001" | ANSI |
| 2014699 | 28IQN | .500" | .001" | 0-100 | • | .100" | 0.002 | ± .001" | ANSI |
| 2014816 | 29I | 1.000" | .01" | 0-1000 | | 1.000" | 0.02 | ± .010" | ANSI |

| Order no. | ANSI/AGD group | Scale diameter | Range per turn | Dial color | Mounting shaft |
|-----------|----------------|----------------|----------------|------------|----------------|
| | | inch | inch | | inch |
| 2011270 | 3 | 2.75 | 0.1000 | Green | 0.375 |
| 2011272 | 3 | 2.75 | 0.1000 | Green | 0.375 |
| 2014698 | 2 | 2.25 | 0.1000 | Green | 0.375 |
| 2014699 | 2 | 2.25 | 0.1000 | Green | 0.375 |
| 2014816 | 2 | 2.25 | 1,0000 | Green | 0.375 |

MarCator D8IS / D8IT / 28ISN / 28IQN / 29I

Dial indicator

ACCESSORIES

| Order no. | Description | Type |
|-----------|---|-----------|
| 2011341 | Magnetic maximum hand (option) | 2011341 |
| 2204730 | Adjustable back with 1/4-20 thread | BK-10 |
| 2204734 | Horizontal lug back, centered | BK-109 |
| 2204763 | Screw type back 1/4-28 | BK-177 |
| 2204784 | Vertical lug back, centered | BK-431 |
| 2204787 | Flat back | BK-473 |
| 2204791 | Vertical lug back, offset | BK-545 |
| 2204799 | Post back 1/2" Ø | BK-664 |
| 2220546 | Lifting lever to lift probe manually (left) | LR-50 |
| 2220547 | Lifting lever to lift probe manually (right) | LR-51 |
| 2220539 | OX-bow lifting lever | LR-40 |
| 2203185 | Brake attachment (option) | AT-A-7-W3 |
| 2203163 | Brake attachment, dust cap mount (option), range limited to 6.35 mm/ .250" for group 1 and to 12 mm/ .500" for group 2-4 indicators | AT-81 |
| 2219994 | Rubber bellows for shank Ø .375" | GU-2 |
| 2206230 | Range limiting caps, adjustable up to 9.52 mm / .375" | CS-123 |
| 2201801 | Adaptor for inductive probes for use on dial indicators (AGD) | AD-138 |
| 2201846 | Threaded bushing .625" long .500" OD with 5/16-32 internal thread | AD-62 |
| 2201854 | Split collet OD is 17.45 mm/ .687"; requires 1/2-32 threaded hole | AD-87 |
| 2235806 | Tap 1/2 -32 | V-892 |
| 2205081 | Split bushing, for use with protective housing .375" stem hole X .687" OD | BU-111 |
| 2205127 | Split bushing with shoulder 8 mm stem hole X .375" OD | BU-197 |
| 2205195 | Split bushing, with counterbore, .375" stem hole x .500" OD | BU-80 |
| 2205200 | Split bushing without counterbore, .375" stem hole x .50" OD | BU-94 |
| 2204603 | Base for indicators with lug back | BA-1051 |
| 2014804 | Magnetic maximum hand with snap-on bezel (option) | 2014804 |
| 2203133 | Mounting bracket with adjusting knob for AGD 2 | AT-116 |
| 2203156 | Mounting bracket with hex socket adjustable | AT-28 |
| 2204772 | Post back 1/2" Ø | BK-2093 |
| 2204773 | Vertical lug, offset 1/4" hole | BK-2168 |
| 2204780 | Vertical lug back, centered 1/4" hole | BK-383 |
| 2204782 | Horizontal lug back, centered, 1/4" hole | BK-400 |
| 2204786 | Flat back for AGD 2 | BK-470 |
| 2204790 | Adjustable back 1/4-20 Thread | BK-531 |
| 2204802 | Screw type back 1/4-28 | BK-692 |
| 2204812 | Rack back used on AT-116 and AT-28 | BK-93 |
| 2205222 | Tolerance hands with snap-on bezel (option) | BZ-2503 |
| 2220154 | Tolerance hands with screw-on bezel (option) | HD-57 |
| 2220177 | Protective housing for AGD 2 models with ranges up to 6.35 mm/ .250" | HG-100 |
| 2220178 | Protective housing for AGD 2 models with ranges up to 25 mm/ 1" | HG-101 |
| 2220544 | Lifting lever to lift probe manually (left) | LR-48 |
| 2220545 | Lifting lever to lift probe manually (right) | LR-49 |
| 2203184 | Brake attachment (option) | AT-A-7-W2 |



2011341; 2014804

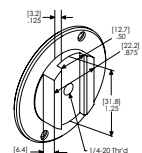

BK-531; BK-10; BK-18

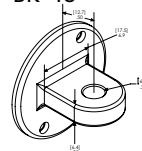

BK-19; BK-400; BK-109



AD-138



HG-100; HG-101



HD-57; HD-53

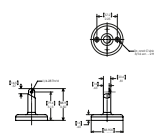

BA-1051



BU-80

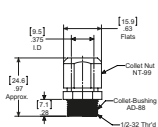

AD-87



LR-48; LR-46;
LR-47; LR-50;
LR-68

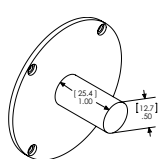

BK-2093;
BK-664;
BK-17

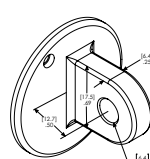

BK-1601;
BK-2168;
BK-545; BK-4

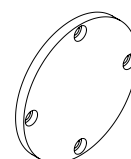

BK-32;
BK-470;
BK-473;
BK-5

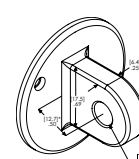

BK-1600;
BK-383;
BK-431;
BK-3

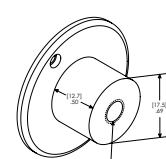

BK-1661;
BK-692;
BK-177;
BK-16

MarCator Q8IT / SP6IS / SQ6IS

Dial indicator

FEATURES

- Unit construction and removable movement save repair/cleaning time and maintenance
- Hardened gears and stainless steel racks provide lasting protection against indicator failure due to shock or wear
- Jeweled bearings resist friction, add to longer indicator life
- Skeletonized, hobbled gears for more sensitive response, superior indicator accuracy with minimal hysteresis error
- Soft tinted dials (green - inch / yellow - metric) minimize eye strain
- Special steel alloy
- Balanced dial hand affords no shift, precise reading
- Controlled rack and pinion mesh eliminates slope for precise response and reading
- Smooth adjusting bezels for easy setup
- Positive pressure pullback spring requires less maintenance
- Normally furnished: continuous clockwise dial; centered vertical lug back; regular contact point, .18" radiused, .250" long
- **Long range models:** include (1) revolution counter (except C9I without revolution counter).
- **Extra long range models:** include (2) revolution counters
- For other dial styles or special requirements - call Mahr



TECHNICAL DATA

| Order no. | Type | Measuring span | Readings | Figure on dial face | Rev. counter | Error limit, measuring range | Error limit | Standard | Scale diameter |
|-----------|-------|----------------|----------|---------------------|--------------|------------------------------|-----------------------------------|----------|----------------|
| | | mm | mm | | | µm | mm | | mm |
| 2011883 | Q8IT | 50 | 0.025 | 0-25 | • | 50 | ± 0.025 for first 25 mm of travel | ANSI | 70 |
| 2012381 | SP6IS | 25 | 0.01 | 0-100 | • | 40 | ± 0.02 | ANSI | 57 |
| 2012384 | SQ6IS | 25 | 0.01 | 0-100 | • | 40 | ± 0.02 | ANSI | 70 |

| Order no. | ANSI/AGD group | Scale diameter | Range per turn | Dial color | Order no. | Mounting shaft |
|-----------|----------------|----------------|----------------|------------|-----------|----------------|
| | | inch | mm | | | inch |
| 2011883 | 3 | 2.75 | 2.5 | Yellow | 2011883 | 0.375 |
| 2012381 | 2 | 2.25 | 1 | Yellow | 2012381 | 0.375 |
| 2012384 | 3 | 2.75 | 1 | Yellow | 2012384 | 0.375 |

ACCESSORIES

| Order no. | Description | Type |
|-----------|---|-----------|
| 2011341 | Magnetic maximum hand (option) | 2011341 |
| 2204730 | Adjustable back with 1/4-20 thread | BK-10 |
| 2204734 | Horizontal lug back, centered | BK-109 |
| 2204763 | Screw type back 1/4-28 | BK-177 |
| 2204784 | Vertical lug back, centered | BK-431 |
| 2204787 | Flat back | BK-473 |
| 2204791 | Vertical lug back, offset | BK-545 |
| 2204799 | Post back 1/2" Ø | BK-664 |
| 2220546 | Lifting lever to lift probe manually (left) | LR-50 |
| 2220547 | Lifting lever to lift probe manually (right) | LR-51 |
| 2220539 | OX-bow lifting lever | LR-40 |
| 2203185 | Brake attachment (option) | AT-A-7-W3 |
| 2203163 | Brake attachment, dust cap mount (option), range limited to 6.35 mm/ .250" for group 1 and to 12 mm/ .500" for group 2-4 indicators | AT-81 |
| 2219994 | Rubber bellows for shank Ø .375" | GU-2 |
| 2206230 | Range limiting caps, adjustable up to 9.52 mm / .375" | CS-123 |
| 2201801 | Adaptor for inductive probes for use on dial indicators (AGD) | AD-138 |
| 2201846 | Threaded bushing .625" long .500" OD with 5/16-32 internal thread | AD-62 |
| 2201854 | Split collet OD is 17.45 mm/ .687"; requires 1/2-32 threaded hole | AD-87 |
| 2235806 | Tap 1/2 -32 | V-892 |
| 2205081 | Split bushing, for use with protective housing .375" stem hole X .687" OD | BU-111 |
| 2205127 | Split bushing with shoulder 8 mm stem hole X .375" OD | BU-197 |
| 2205195 | Split bushing, with counterbore, .375" stem hole x .500" OD | BU-80 |
| 2205200 | Split bushing without counterbore, .375" stem hole x .50" OD | BU-94 |
| 2204603 | Base for indicators with lug back | BA-1051 |
| 2014804 | Magnetic maximum hand with snap-on bezel (option) | 2014804 |
| 2203133 | Mounting bracket with adjusting knob for AGD 2 | AT-116 |
| 2203156 | Mounting bracket with hex socket adjustable | AT-28 |
| 2204772 | Post back 1/2" Ø | BK-2093 |
| 2204773 | Vertical lug, offset 1/4" hole | BK-2168 |
| 2204780 | Vertical lug back, centered 1/4" hole | BK-383 |
| 2204782 | Horizontal lug back, centered, 1/4" hole | BK-400 |
| 2204786 | Flat back for AGD 2 | BK-470 |
| 2204790 | Adjustable back 1/4-20 Thread | BK-531 |
| 2204802 | Screw type back 1/4-28 | BK-692 |
| 2204812 | Rack back used on AT-116 and AT-28 | BK-93 |
| 2205222 | Tolerance hands with snap-on bezel (option) | BZ-2503 |
| 2220154 | Tolerance hands with screw-on bezel (option) | HD-57 |
| 2220177 | Protective housing for AGD 2 models with ranges up to 6.35 mm/ .250" | HG-100 |
| 2220178 | Protective housing for AGD 2 models with ranges up to 25 mm/ 1" | HG-101 |
| 2220544 | Lifting lever to lift probe manually (left) | LR-48 |
| 2220545 | Lifting lever to lift probe manually (right) | LR-49 |
| 2203184 | Brake attachment (option) | AT-A-7-W2 |



2011341; 2014804

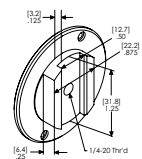

BK-531; BK-10; BK-18

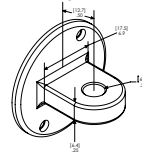

BK-19; BK-400; BK-109



AD-138



HG-100; HG-101



HD-57; HD-53

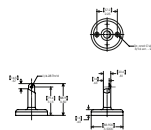

BA-1051



BU-80

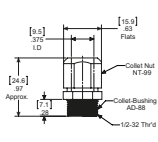

AD-87



LR-48; LR-46;
LR-47; LR-50;
LR-68

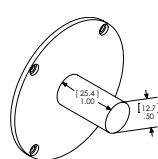

BK-2093;
BK-664;
BK-17

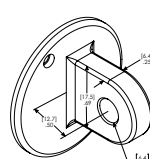

BK-1601;
BK-2168;
BK-545; BK-4

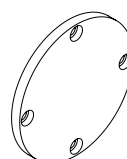

BK-32;
BK-470;
BK-473;
BK-5

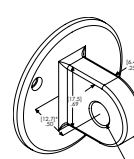

BK-1600;
BK-383;
BK-431;
BK-3

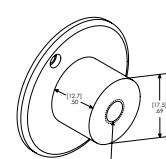

BK-1661;
BK-692;
BK-177;
BK-16

MarCator

Dial indicator

FEATURES

- Outstanding quality due to a well thought out design, use of high quality materials, and the precision engineered mechanism's guarantee
- The concentric "Speed Read" pointer (on 1.0" and .500" models) allows easy and safe reading of this dial indicator
- Spindle and stem are made of resistant stainless steel
- **Supplied with:** lug back and tolerance hands



TECHNICAL DATA

| Order no. | Measuring span | Scale graduation value | Figure on dial face | Rev. counter | Range per turn | Error limit, measuring range | Error limit | Standard | ANSI/AGD group |
|-----------|----------------|------------------------|---------------------|--------------|----------------|------------------------------|-------------|----------|----------------|
| | inch | inch | | | inch | inch | inch | | |
| 2016002 | 1.000" | .001" | 0-100 | • | .100" | 0.002 | ±.001" | ANSI | 2 |
| 2016004 | .500" | .001" | 0-100 | • | .100" | 0.002 | ±.001" | ANSI | 2 |
| 2016005 | .250" | .001" | 0-100 | • | .100" | 0.002 | ±.001" | ANSI | 2 |

| Order no. | Scale diameter | Range per turn | Dial color | Mounting shaft |
|-----------|----------------|----------------|------------|----------------|
| | inch | inch | | inch |
| 2016002 | 2.25 | 0.1000 | Green | 0.375 |
| 2016004 | 2.25 | 0.1000 | Green | 0.375 |
| 2016005 | 2.25 | 0.1000 | Green | 0.375 |

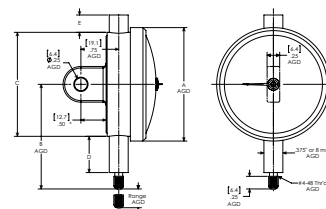

ACCESSORIES

| Order no. | Description |
|-----------|-----------------|
| 2247145 | Flat back |
| 2016010 | Adjustable back |
| 2016007 | Lug back |
| 2016009 | Post back |
| 2016008 | Screw back |

MarCator 400B-3 / 400B-4

Mobile dial calibrator

FEATURES

- For checking and calibrating dial indicators, test indicators, digital indicators, and LVDT inductive probes
- Large micrometer style wheel has widely spaced graduations for easy setting and viewing
- Adjustable crosshair provides exact on-the-mark setting
- Anvil uses tungsten carbide for maximum wear resistance
- Indicator clamped in line with micrometer spindle for direct contact measurement
- **Data interface:** none
- **Package contains:** adapter bushing AD-58, split bushing BU-112, split bushing BU-197



Application:

- Portable dial calibrator

TECHNICAL DATA

| Order no. | Type | Measuring span | | Readings | Scale graduation value | | Error limit | | Range per turn | |
|-----------|--------|----------------|--------|----------|------------------------|-------|-------------|------|----------------|------|
| | | mm | inch | | mm | inch | mm | inch | mm | inch |
| 2050665 | 400B-3 | | 1.000" | 0.002 | .0001" | 0.001 | .00005" | 0.05 | 0.0025 | |
| 2050666 | 400B-4 | 25 | | | | | | | | |

ACCESSORIES

| Order no. | Description | Type |
|-----------|---|--------|
| 4305893 | Universal centering support frame | 800 b |
| 2201843 | Adaptor bushing 0.275" ID to 0.375" OD | AD-58 |
| 2205127 | Split bushing with shoulder 8 mm stem hole X .375" OD | BU-197 |
| 2205082 | Split bushing .218" x .374" x .5" | BU-112 |

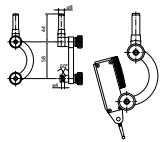

800 b

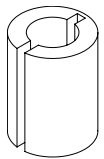

BU-112

Millimess | Digital and dial comparators

Millimess dial comparators differ from conventional dial indicators through more precise components, greater accuracy and improved hysteresis. Millimess dial comparators are especially suitable for radial runout, straightness and flatness measurements as well for comparative measurements. Other outstanding advantages include its easy handling, reliable readability and absolute shock resistance of the measuring mechanism.



| | |
|--|------------|
| Millimes overview | 184 |
| Dial comparator | |
| Millimes 2000 W / 2000 Wi | 188 |
| Inductive dial comparator | |
| Millimes 2001 W / 2001 Wi | 190 |
| Inductive dial comparator | |
| Millimes μMaxμm II | 194 |
| Inductive dial comparator | |
| Millimes μMaxμm III | 197 |
| Inductive digital comparator | |
| Mechanical dial comparator | |
| Millimes 1002 / 1002 T / 1003 / 1003 T | 206 |
| Mechanical dial comparator | |
| Millimes 1004 / 1004 T / 1003 XL / 1003 XLT | 207 |
| Mechanical dial comparator | |
| Millimes 1003 | 208 |
| Mechanical dial comparator with special measuring force | |
| Millimes 1000 A / 1000 B | 209 |
| Mechanical dial comparator | |
| Millimes 1010 / 1010 T | 210 |
| Mechanical dial comparator | |
| Millimes 1010 Z | 211 |
| Mechanical dial comparator | |

Millimess 2001 Wi: Everything under control! A digital comparator – highest level of precision due to inductive measuring system



Integrated Wireless

- Integrated Wireless interface
- Sending and receiving measuring data and various parameters



Lock individual keys and functions

Remote-controlled settings can be configured easily using MarCom Professional Software



Can be configured and controlled remotely using MarCom Professional Software



First digital comparator indicator with touch operation



Unique touch operation – even works with gloves

Extensive advantages:

- Keys react even with the slightest touch
- This prevents a measuring device from being adjusted or deformed
- **Maximum measuring certainty**

Hardened glass front

- Scratch and impact-resistant surface
- Excellent protection against scratches and penetrating liquids
- Wear-free keys react to the slightest touch



Protection rating IP 64

Excellent protection against dust and splash water from all directions ensures optimum workshop compatibility at all times



High-precision ball-bearing guide

Maximum sensitivity of the measuring system, long service life, and high loading capacity

Bidirectional data interface via USB

- Sending and receiving measuring data and various parameters
- Permanent power supply via data cable
- Possible to retrieve the device ID

#ID

Data interface via Digimatic

- To send measuring data



Convenient tolerance functions

- Clear tolerance symbols
- Colorful LED signals (red, green, yellow) to classify the measuring values
 - No go/Go/warning limit
 - No go/Go/rework

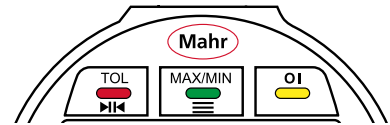

High precision inductive measuring system

Lowest measuring deviations thanks to linearization

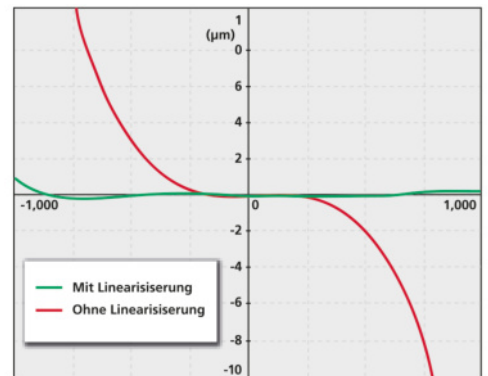

ABS
system

Absolute measuring system

The reference to the electric zero point is not lost when the device is switched off



Millimes | Digital and dial comparators – design

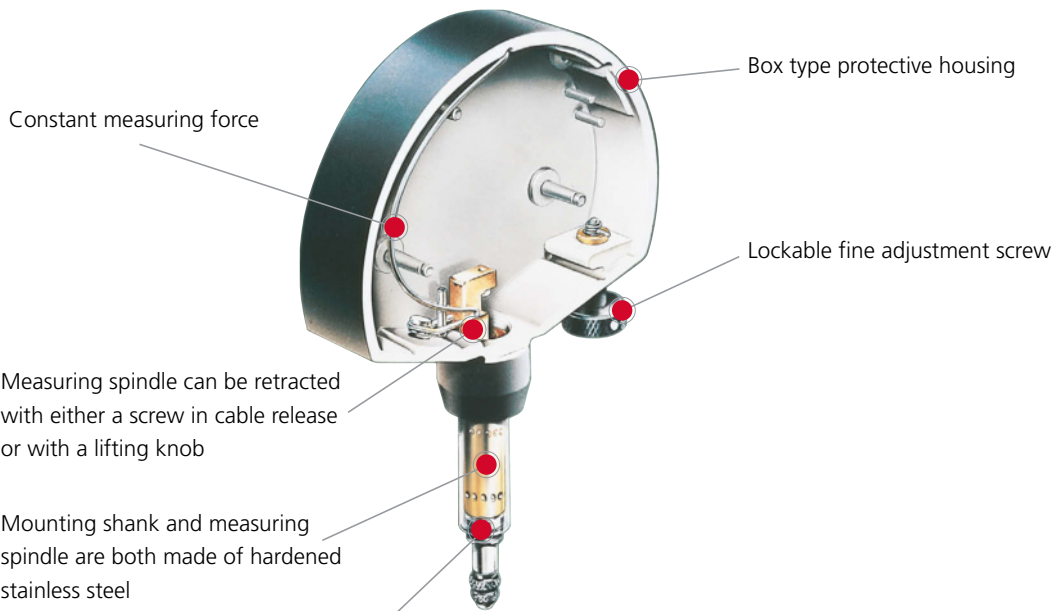

Measuring spindle is mounted in a high precision ball guide (Types 1000 / 1002 / 1003 / 1004) for minimal hysteresis



Resistant to lateral forces (side play) acting on the measuring spindle

Self contained movement, which is quick and easy to remove and replace

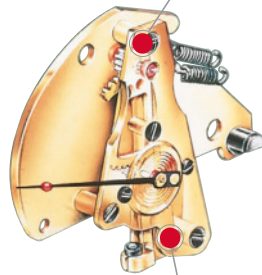

Maximum sensitivity and accuracy are ensured by the jeweled movement in conjunction with the precision gears and pinions

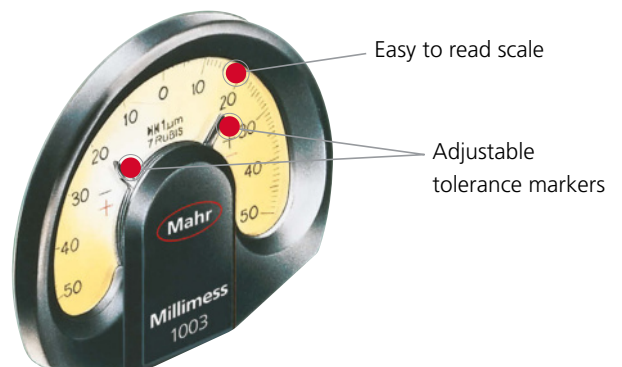

Millimes | Shockproof mechanism

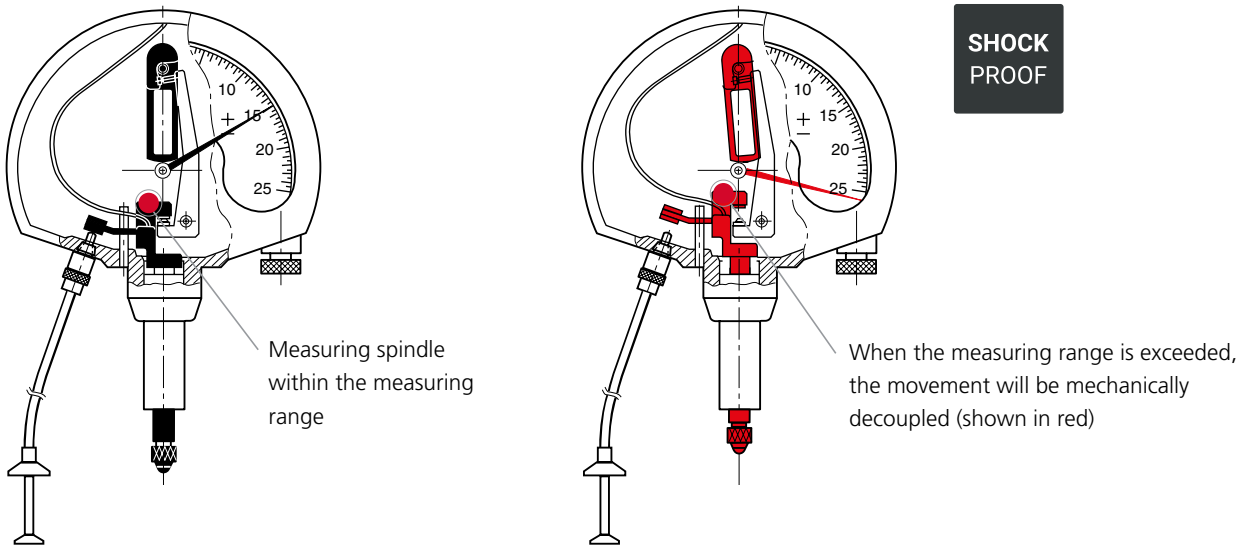

Millimes | Metrological characteristics

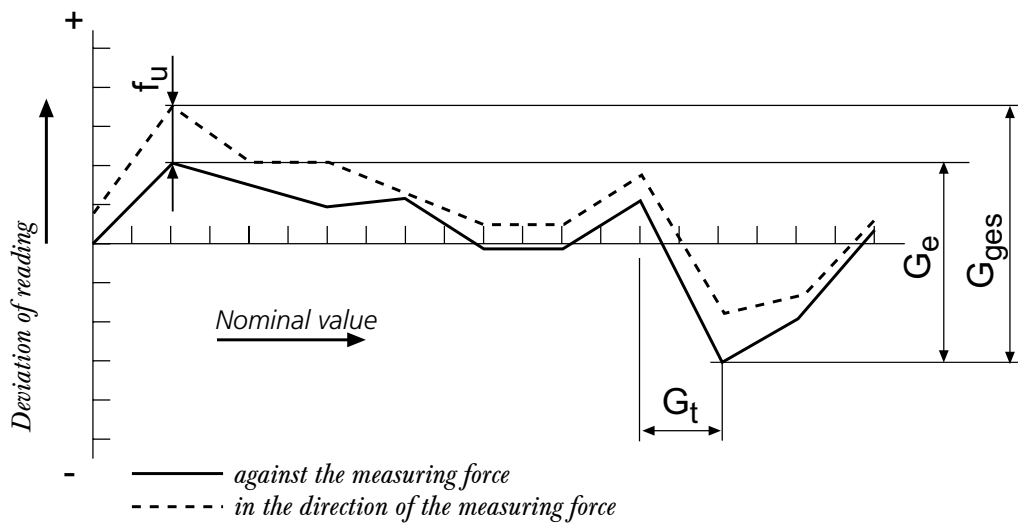

Millimes | Versions



Inductive digital comparator



Mechanical digital comparator



Mechanical digital comparator with protection class IP 54

Millimes 2000 W / 2000 Wi

Inductive dial comparator



FUNCTIONS

- ON/OFF
- mm/inch
- RESET (set display to zero)
- PRESET (for entering a numerical value)
- ABS (reference to the electrical zero point)
- Selectable resolution
- TOL (tolerance and warning limits input)
- Factor (adjustable)
- Reversal of counting direction
- HOLD (storage of measured values)
- LOCK function (key lock)
- DATA (data transmission)
- Bidirectional data interface (external output and input option of characteristic values as well as setting of individual lock functions by MarCom Software)

FEATURES

- Advantages of tempered glass front with touch control panels:
 - Scratch and impact resistant surface
 - Excellent protection against dust, coolants and lubricants
 - Wear-free touch operating keys
 - Improved safety of measurement values in measuring stands, as only a light touch of the key
 - No keystroke - is required, thus no adjustment or deformation of the measuring device
- High contrast LCD display
- Clear tolerance symbols and colored LED signals (red, green, yellow) for measured value classification
 - **with** warning limit input: No Go / Go / Warning Limit
 - **without** warning limit input: No Go / Go / Rework
- Operating and display unit (bezel) can be rotated through 280°
- Mounting shank and measuring spindle are both made of hardened stainless steel
- Measuring spindle is mounted in a high precision ball guide for minimal hysteresis
- Linearized inductive absolute measuring system
- Measuring force spring is interchangeable
- Lower stop is adjustable
- **Software:** MarCom Professional free download: www.mahr.com/marcom (only for Mahr data cables and wireless systems with USB and RS-232 interface)
- **Digit height:** 11.5 mm
- **Energy supply:** Integrated



Application:

- For static measuring tasks

TECHNICAL DATA

| Order no. | 4346700 | 4346701 |
|---|----------------|---|
| Type | 2000 W | 2000 Wi |
| Measuring range | mm | ± 1 |
| Measuring range | inch | ± .04" |
| Resolution | mm | 0.0001, 0.0002, 0.0005, 0.001, 0.002, 0.005, 0.01 |
| Resolution | inch | .000005", .00001", .00002", .00005", .0001", .0002", .0005" |
| Error limit | µm | ± (0.2 + L/2) L in mm |
| Measuring value hysteresis f _v | µm | 0.3 |
| Repeatability f _w | µm | 0.1 |
| Standard | | Factory standard |
| Free stroke | mm | 2.5 |
| Measuring force | N | 0.9 ±0.1 (at the electrical zero point) |
| IP protection category | | IP 64 |
| Data interface | USB, Digimatic | Integrated Wireless, USB, Digimatic |
| Supply voltage | | 100–240 V |

| Order no. | Mounting shaft |
|-----------|----------------|
| | mm |
| 4346700 | 8 |
| 4346701 | 8 |

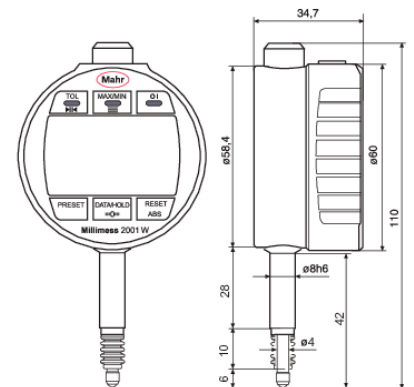

rechargeable accumulator (up to 4 weeks) or powered by USB data cable

- **Battery type:** Lithium Polymer Accu 3.7 V
- **Package contains:** instruction manual, USB data and charging cable type DK-U1, plug-in power supply (with 4 interchangeable adapters) for USB, rubber bellows, screwdriver for pre-stroke adjustment (hexagon socket 0.9 mm), case

Millimess 2000 W / 2000 Wi

Inductive dial comparator

ACCESSORIES

| Order no. | Description | Type |
|-----------|---|---------|
| 4102603 | Data cable USB bidirectional (2 m) | DK-U1 |
| 4102606 | Interface adapter with data cable Digimatic (2 m) | DK-D1 |
| 4310103 | Adapter bushing (.375" / 8 mm) | 940 |
| 4346010 | Manual lifer with cable release | 2000 h |
| 4346011 | Pneumatic lifter | 2000 p |
| 4346012 | Measuring force adjuster | 2000 m |
| 4337421 | Lug back | 1086 b |
| 4346050 | Measuring force spring 0.25 N | |
| 4346051 | Measuring force spring 0.50 N | |
| 4882284 | Measuring force spring 0.75 N | |
| 4346052 | Measuring force spring 1.00 N | |
| 4346053 | Measuring force spring 1.50 N | |
| 4346054 | Measuring force spring 2.00 N | |
| 4346055 | Measuring force spring 2.50 N | |
| 4337900 | Display protection film, anti reflective frosted, made of extra hard hybrid glass, to protect against scratches and reflections | 1086 sf |
| 4346606 | Shock protection ring made of hard rubber for Millimess 2000 W(i) / 2001 W(i) | 1086 sr |
| 4102220 | Receiver for instruments with Integrated Wireless | i-Stick |

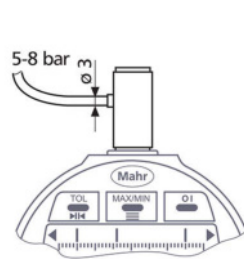

2000 p

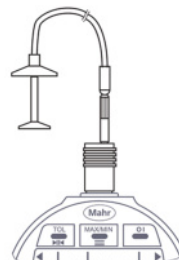

2000 h



2000 m



1086 sf



1086 sr



i-stick

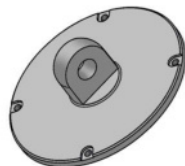

1086 b

Millimess 2001 W / 2001 Wi

Inductive dial comparator

ACCESSORIES

| Order no. | Description | Type |
|-----------|---|---------|
| 4102603 | Data cable USB bidirectional (2 m) | DK-U1 |
| 4102606 | Interface dapter with data cable Digimatic (2 m) | DK-D1 |
| 4310103 | Adapter bushing (.375" / 8 mm) | 940 |
| 4346010 | Manual lifer with cable release | 2000 h |
| 4346011 | Pneumatic lifter | 2000 p |
| 4346012 | Measuring force adjuster | 2000 m |
| 4337421 | Lug back | 1086 b |
| 4346050 | Measuring force spring 0.25 N | |
| 4346051 | Measuring force spring 0.50 N | |
| 4882284 | Measuring force spring 0.75 N | |
| 4346052 | Measuring force spring 1.00 N | |
| 4346053 | Measuring force spring 1.50 N | |
| 4346054 | Measuring force spring 2.00 N | |
| 4346055 | Measuring force spring 2.50 N | |
| 4337900 | Display protection film, anti reflective frosted, made of extra hard hybrid glass, to protect against scratches and reflections | 1086 sf |
| 4346606 | Shock protection ring made of hard rubber for Millimess 2000 W(i) / 2001 W(i) | 1086 sr |
| 4102220 | Receiver for instruments with Integrated Wireless | i-Stick |

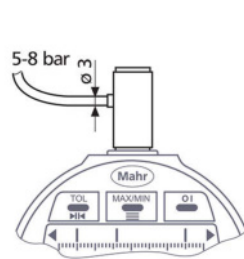

2000 p

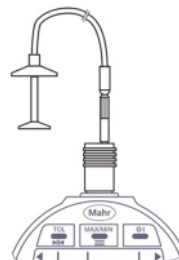

2000 h



2000 m



1086 sf



1086 sr



i-stick

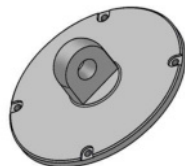

1086 b

Millimess 2001 Wi

Inductive dial comparator



FUNCTIONS

- ON/OFF
- RESET (set display to zero)
- PRESET (for entering a numerical value)
- ABS (reference to the electrical zero point)
- Selectable resolution
- TOL (tolerance and warning limits input)
- RANGE (switch the measuring range and resolution)
- MAX/MIN (memory for searching the reversal point)
- MAX-MIN (for testing flatness and concentricity)
- 0 (set the analog scale display to zero)
- Factor (adjustable)
- Reversal of counting direction
- HOLD (storage of measured values)
- LOCK function (key lock)
- DATA (data transmission)
- Bidirectional data interface (external output and input option of characteristic values as well as setting of individual lock functions by MarCom Software)

FEATURES

- Advantages of tempered glass front with touch control panels:
 - Scratch and impact resistant surface
 - Excellent protection against dust, coolants and lubricants
 - Wear-free touch operating keys
 - Improved safety of measurement values in measuring stands, as only a light touch of the key
 - No keystroke - is required, thus no adjustment or deformation of the measuring device
- Clear tolerance limits in the scale display and colored LED signals (red, green, yellow) for measured value classification
 - **with** warning limit input: No Go / Go / Warning Limit
 - **without** warning limit input: No Go / Go / Rework
- LED signals (red, green, yellow) in mode:
 - Powered by accumulator: flashing signal (1 sec.)
 - Powered by data cable DK-U1: permanent
- High contrast LCD display
- Analog scale display for visual recognition of the measuring movement during dynamic measurement tasks such as checking of concentricity or flatness as well as for reversal point search during bore measurements
- Operating and display unit (bezel)



Applications:

- For static and dynamic measuring tasks
- **Version:** Unit of measurement only METRIC (without INCH)

TECHNICAL DATA

| Order no. | | 4346811 | |
|----------------------------------|----|--|--|
| Type | | 2001 Wi | |
| Measuring range | mm | ± 1 | |
| Resolution | mm | 0.0001, 0.0002, 0.0005, 0.001, 0.002, 0.005, 0.01 | |
| Error limit | µm | ± (0.2 + L/2) L in mm | |
| Measuring value hysteresis f_u | µm | 0.3 | |
| Repeatability f_w | µm | 0.1 | |
| Standard | | Factory standard | |
| Free stroke | mm | 2.5 | |
| Measuring force | N | 0.9 ± 0.1 (at the electrical zero point) | |
| Range of analog display | mm | ± 0.002, ± 0.004, ± 0.01, ± 0.02, ± 0.04, ± 0.1, ± 0.2 | |
| IP protection category | | IP 64 | |
| Data interface | | Integrated Wireless, USB, Digimatic | |
| Supply voltage | | 100–240 V | |

| Order no. | Mounting shaft |
|-----------|----------------|
| | mm |
| 4346811 | 8 |

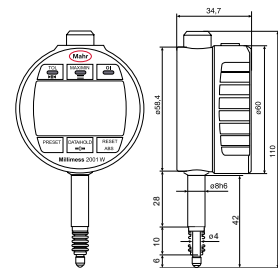

- can be rotated through 280°
- Mounting shank and measuring spindle are both made of hardened stainless steel
- Measuring spindle is mounted in a high precision ball guide for minimal hysteresis
- Linearized inductive absolute measuring system
- Measuring force spring is interchangeable
- Lower stop is adjustable
- **Software:** MarCom Professional free download: www.mahr.com/marcom (only for Mahr data cables and wireless systems with USB and RS-232 interface)
- **Digit height:** 9 mm

- **Energy supply:** Integrated rechargeable accumulator (up to 4 weeks) or powered by USB data cable
- **Battery type:** Lithium Polymer Accu 3.7 V
- **Package contains:** instruction manual, USB data and charging cable type DK-U1, plug-in power supply (with 4 interchangeable adapters) for USB, rubber bellows, screwdriver for pre-stroke adjustment (hexagon socket 0.9 mm), case

Millimess 2001 Wi

Inductive dial comparator

ACCESSORIES

| Order no. | Description | Type |
|-----------|---|---------|
| 4102220 | Receiver for instruments with Integrated Wireless | i-Stick |
| 4102603 | Data cable USB bidirectional (2 m) | DK-U1 |
| 4102606 | Interface adapter with data cable Digimatic (2 m) | DK-D1 |
| 4310103 | Adapter bushing (.375" / 8 mm) | 940 |
| 4346010 | Manual lifer with cable release | 2000 h |
| 4346011 | Pneumatic lifter | 2000 p |
| 4346012 | Measuring force adjuster | 2000 m |
| 4337421 | Lug back | 1086 b |
| 4346050 | Measuring force spring 0.25 N | |
| 4346051 | Measuring force spring 0.50 N | |
| 4882284 | Measuring force spring 0.75 N | |
| 4346052 | Measuring force spring 1.00 N | |
| 4346053 | Measuring force spring 1.50 N | |
| 4346054 | Measuring force spring 2.00 N | |
| 4346055 | Measuring force spring 2.50 N | |
| 4337900 | Display protection film, anti reflective frosted, made of extra hard hybrid glass, to protect against scratches and reflections | 1086 sf |
| 4346606 | Shock protection ring made of hard rubber for Millimess 2000 W(i) / 2001 W(i) | 1086 sr |



i-Stick

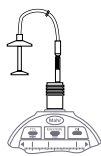

2000 h

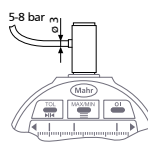

2000 p

Millimes μMaxμm II

Inductive digital comparator



FUNCTIONS

- ON/OFF
- RESET (set display to zero)
- mm/inch
- Reversal of counting direction
- ABS (display can be set to zero without losing reference to preset)
- MAX/MIN (memory for searching the reversal point)
- MAX-MIN (for testing flatness and concentricity)
- Factor (adjustable)
- HOLD (storage of measured values)



FEATURES

- Inductive absolute measuring system
- Large, high contrast display with numerical and scale display
- Control and display unit rotatable through 270°
- Zero point setting is retained even after switching off the dial indicator

Optional Factory Configured Features:

- Locked multiplier factor for ratio measurements
- Disabled sleep mode (manual ON/OFF)
- Locked inch or mm display unit
- Power up in inch or mm unit on battery change
- Calibration mode lockout (with password entry)
- Setup mode lockout (with password entry)
- **Software:** MarCom Professional free download: www.mahr.com/marcom (only for Mahr data cables and wireless systems with USB and RS-232 interface)
- **Digit height:** 8 mm
- **Energy supply:** battery operation
- **Battery type:** CR 2450N (3V Lithium)
- **Package contains:** instruction manual, battery

TECHNICAL DATA

| Order no. | 2034201 | 2034203 | 2034205 | 2034207 |
|--|------------------------------|--|---------|---------|
| Type | μMaxμm II | | | |
| Measuring range | mm | ±1 | | |
| Measuring range | inch | ±.040" | | |
| Resolution | mm | 0.0002, 0.0005, 0.001, 0.002, 0.005, 0.01, 0.02 | | |
| Resolution | inch | .00001", .00002", .00005", .0001", .0002", .0005", .001" | | |
| Error limit | μm | ± 5 | | |
| Error limit in partial measuring range | μm | ± 1.25 | | |
| Partial measuring range | mm | ± 0.5 | | |
| Standard | Factory standard | | | |
| Measuring force | N | 0.8 – 1.1 | | |
| IP protection category | IP 54 | | | |
| Data interface | Digimatic, Opto RS-232C, USB | | | |

| Order no. | a | b | c | Mounting shaft | Mounting shaft |
|-----------|------|------|------|----------------|----------------|
| | mm | mm | mm | inch | mm |
| 2034201 | 11.7 | 24.1 | 53.6 | 0.375 | |
| 2034203 | 38 | 57.2 | 86.6 | 0.375 | |
| 2034205 | 11.7 | 24.1 | 53.6 | | 8 |
| 2034207 | 38 | 57.2 | 86.6 | | 8 |

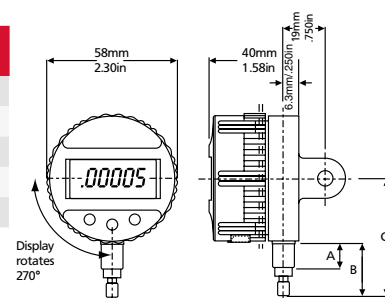

ACCESSORIES

| Order no. | Description | Type |
|-----------|---|-------------|
| 2210555 | Lug back | EBK-1010 |
| 2212878 | Splash guard cover | ECV-1307-W2 |
| 4310103 | Adapter bushing (.375" / 8 mm) | 940 |
| 4346023 | 2000 USB data connection cable USB (2 m) | 2000 USB |
| 4346021 | Interface adapter with data cable Digimatic (2 m) | 2000 d |
| 4346020 | Data connection cable RS232C (2 m) | 2000 r |
| 4102232 | 2000 e Transmitter for e-Stick | 2000 e |
| 4102230 | e-Stick receiver | e-Stick |
| 2210556 | Back panel with cylindrical holder, Ø = .5", l = 1" | EBK-1012 |
| 2210557 | Back panel with threaded bore 1/4-28, Ø = 11/16", l = .5" | EBK-1013 |
| 2210561 | Flat back panel | EBK-1018 |
| 2210559 | Back panel with adjustable holder | EBK-1016 |
| 2210558 | Back panel with rack | EBK-1014 |
| 2232570 | Measuring force springs 0.35N | SP-351 |

Millimes μMaxμm II

Inductive digital comparator



FUNCTIONS

- ON/OFF
- RESET (set display to zero)
- mm/inch
- Reversal of counting direction
- ABS (display can be set to zero without losing reference to preset)
- MAX/MIN (memory for searching the reversal point)
- MAX-MIN (for testing flatness and concentricity)
- Factor (adjustable)
- HOLD (storage of measured values)

FEATURES

- Inductive absolute measuring system
- Large, high contrast display with numerical and scale display
- Control and display unit rotatable through 270°
- Zero point setting is retained even after switching off the dial indicator

Optional Factory Configured Features:

- Locked multiplier factor for ratio measurements
- Disabled sleep mode (manual ON/OFF)
- Locked inch or mm display unit
- Power up in inch or mm unit on battery change
- Calibration mode lockout (with password entry)
- Setup mode lockout (with password entry)
- **Software:** MarCom Professional free download: www.mahr.com/marcom (only for Mahr data cables and wireless systems with USB and RS-232 interface)
- **Digit height:** 8 mm
- **Energy supply:** battery operation
- **Battery type:** CR 2450N (3V Lithium)
- **Package contains:** instruction manual, battery



Applications:

- Vertical design with perpendicular measuring spindle
- For static and dynamic measurements

TECHNICAL DATA

| Order no. | 2034401 | | |
|--|------------------------------|--|--|
| Type | μMaxμm II | | |
| Measuring range | mm | ±1 | |
| Measuring range | inch | ± .040" | |
| Resolution | mm | 0.0002, 0.0005, 0.001, 0.002, 0.005, 0.01, 0.02 | |
| Resolution | inch | .00001", .00002", .00005", .0001", .0002", .0005", .001" | |
| Error limit | μm | ± 5 | |
| Error limit in partial measuring range | μm | ± 1.25 | |
| Partial measuring range | mm | ± 0.5 | |
| Standard | Factory standard | | |
| Measuring force | N | 0.8 – 1.1 | |
| IP protection category | IP 54 | | |
| Data interface | Digimatic, Opto RS-232C, USB | | |

| Order no. | a | b | Mounting shaft |
|-----------|------|------|----------------|
| | mm | mm | inch |
| 2034401 | 11.7 | 24.1 | 0.375 |

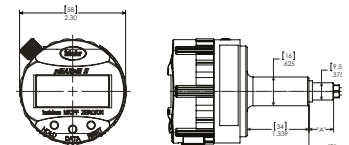

ACCESSORIES

| Order no. | Description | Type |
|-----------|---|-------------|
| 2212878 | Splash guard cover | ECV-1307-W2 |
| 2232570 | Measuring force springs 0.35N | SP-351 |
| 2201833 | Thread adapter, M2.5 male to #4-48 female threads | AD-185 |
| 4310103 | Adapter bushing (.375" / 8 mm) | 940 |
| 4346023 | 2000 USB data connection cable USB (2 m) | 2000 USB |
| 4346021 | Interface adapter with data cable Digimatic (2 m) | 2000 d |
| 4346020 | Data connection cable RS232C (2 m) | 2000 r |

Millimes µMaxµm II

Inductive digital comparator



FUNCTIONS

- ON/OFF
- PRESET (for entering a numerical value)
- RESET (set display to zero)
- Selectable resolution
- Reversal of counting direction
- <0> (tolerance GO / NO GO display mode)
- mm/inch

FEATURES

- Inductive absolute measuring system
- Large, high contrast display with numerical and scale display
- Control and display unit rotatable through 270°
- Zero point setting is retained even after switching off the dial indicator

Optional Factory ConFigureed Features:

- Locked multiplier factor for ratio measurements
- Disabled sleep mode (manual ON/OFF)
- Locked inch or mm display unit
- Power up in inch or mm unit on battery change
- Calibration mode lockout (with password entry)
- Setup mode lockout (with password entry)
- **Software:** MarCom Professional free download: www.mahr.com/marcom (only for Mahr data cables and wireless systems with USB and RS-232 interface)
- **Digit height:** 8 mm
- **Energy supply:** battery operation
- **Battery type:** CR 2450N (3V Lithium)
- **Package contains:** instruction manual, battery

Application:

- For static measurements

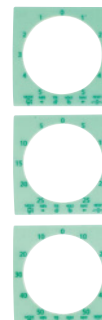

TECHNICAL DATA

| Order no. | 2034101 | 2034103 | 2034105 | 2034107 |
|--|------------------------------|--|---------|---------|
| Type | µMaxµm II | | | |
| Measuring range | mm | ±1 | | |
| Measuring range | inch | ±.040" | | |
| Resolution | mm | 0.0002, 0.0005, 0.001, 0.002, 0.005, 0.01, 0.02 | | |
| Resolution | inch | .00001", .00002", .00005", .0001", .0002", .0005", .001" | | |
| Error limit | µm | ± 5 | | |
| Error limit in partial measuring range | µm | ± 1.25 | | |
| Partial measuring range | mm | ± 0.5 | | |
| Standard | Factory standard | | | |
| Measuring force | N | 0.8 – 1.1 | | |
| IP protection category | IP 54 | | | |
| Data interface | Digimatic, Opto RS–232C, USB | | | |

| Order no. | a | b | c | Mounting shaft | Mounting shaft |
|-----------|------|------|------|----------------|----------------|
| | mm | mm | mm | inch | mm |
| 2034101 | 11.7 | 24.1 | 53.6 | 0.375 | |
| 2034103 | 38 | 57.2 | 86.6 | 0.375 | |
| 2034105 | 11.7 | 24.1 | 53.6 | | 8 |
| 2034107 | 38 | 57.2 | 86.6 | | 8 |

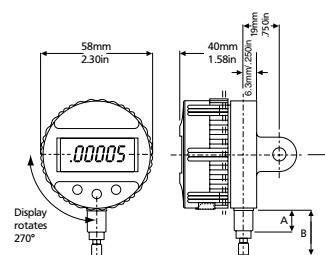

ACCESSORIES

| Order no. | Description | Type |
|-----------|---|-------------|
| 2210555 | Lug back | EBK–1010 |
| 2210556 | Back panel with cylindrical holder, Ø = .5", l = 1" | EBK–1012 |
| 2210557 | Back panel with threaded bore 1/4–28, Ø = 11/16", l = .5" | EBK–1013 |
| 2210558 | Back panel with rack | EBK–1014 |
| 2210559 | Back panel with adjustable holder | EBK–1016 |
| 2210561 | Flat back panel | EBK–1018 |
| 2212878 | Splash guard cover | ECV–1307-W2 |
| 2232570 | Measuring force springs 0.35N | SP–351 |
| 2201833 | Thread adapter, M2.5 male to #4–48 female threads | AD–185 |
| 4310103 | Adapter bushing (.375" / 8 mm) | 940 |
| 4346023 | 2000 USB data connection cable USB (2 m) | 2000 USB |
| 4346021 | Interface adapter with data cable Digimatic (2 m) | 2000 d |
| 4346020 | Data connection cable RS232C (2 m) | 2000 r |
| 4102230 | e-Stick receiver | e-Stick |
| 4102232 | Transmitter for e-Stick | 2000 e |



e-Stick



2000 e

Millimes Maxµm III

Display unit



FUNCTIONS

- RESET (set display to zero)
- mm/inch
- Reversal of counting direction
- RANGE (switch the measuring range and resolution)
- ABS (reference to the electrical zero point)
- TOL (enter tolerance limit values)
- MAX/MIN (memory for searching the reversal point)
- MAX-MIN (for testing flatness and concentricity)
- HOLD (storage of measured values)

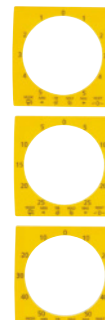

FEATURES

- Large, high contrast digital, analog and fan display for better readability while testing flatness and concentricity as well as for searching the reversal point in bores
- Interchangeable dials
- Inductive absolute measuring system
- Metal cast housing with robust buttons
- **Software:** MarCom Professional free download: www.mahr.com/marcom (only for Mahr data cables and wireless systems with USB and RS-232 interface)
- **Energy supply:** battery operation, battery life approx. 4000 hrs.
- **Package contains:** interchangeable dials, battery, instruction manual

TECHNICAL DATA

| Order no. | 2033001 | 2033011 | 2033021 |
|------------------------|------------------|-------------------------|--------------------|
| Type | Maxµm III | | |
| Measuring range | mm | Dependent on probe type | |
| Standard | Factory standard | | |
| Measuring force | N | - | |
| IP protection category | IP 54 | | |
| Data interface | None | RS-232C, Digimatic | Digimatic, RS-232C |

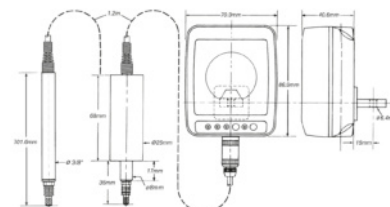

ACCESSORIES

| Order no. | Description | Type |
|-----------|---|-------------|
| 2239138 | Battery for Maxµm III type CR 123A | |
| 2212877 | Dust cover | ECV-1307-W1 |
| 2239040 | Set of 3 inch and 3 metric scale overlay | |
| 2217907 | Spare screws for back panels | ESW-1252 |
| 2240545 | Maxµm III, unlock setup and unlock calibration key, (D, E1) | |
| 2239035 | Interface adapter with data cable Digimatic (2 m) (D, E1) | |
| 2239036 | Data cable RS232C (2 m) (D, E1) | |
| 2240547 | Maxµm III, unlock setup and unlock calibration key, remove (E2) | |
| 2239037 | Interface adapter with data cable Digimatic (2 m) (E2) | |
| 2239038 | Data connection cable RS232C (2 m) (E2) | |
| 2121428 | USB data cable for Maxµm III (2 m) (E1) | |

Millimes Maxµm III

Digital probe

FEATURES

- Maxµm transducers are available as replacement parts - refer to part price list for part numbers and pricing
- Maxµm III remote indicating units are sold without digital transducer
- Any digital transducer may be used with a Maxµm III remote indicating unit
- For alternate cable lengths, extension cables or special indicator options - call Mahr's Technical Assistance Group
- **Software:** MarCom Professional free download: www.mahr.com/marcom (only for Mahr data cables and wireless systems with USB and RS-232 interface)



TECHNICAL DATA

| Order no. | | 2033091 | 2033092 | 2033093 | 2033094 | 2033095 | 2033096 | 2033097 | 2033098 |
|--|------|----------------------------------|----------------|----------------------------------|----------------|----------------------------------|----------------|----------------------------------|----------------|
| Type | | Maxµm III | | | | | | | |
| Measuring range | mm | ± 1.00 | ± 1.99 | ± 1.00 | ± 1.99 | ± 1.00 | ± 1.99 | ± 1.00 | ± 1.99 |
| Measuring range | inch | ± .040" | ± .100" | ± .040" | ± .100" | ± .040" | ± .100" | ± .040" | ± .100" |
| Resolution | mm | 0.0005, 0.001, 0.005 | 0.001, 0.005 | 0.0005, 0.001, 0.005 | 0.001, 0.005 | 0.0005, 0.001, 0.005 | 0.001, 0.005 | 0.0005, 0.001, 0.005 | 0.001, 0.005 |
| Resolution | inch | .00002", .00005", .0001", .0005" | .0001", .0005" | .00002", .00005", .0001", .0005" | .0001", .0005" | .00002", .00005", .0001", .0005" | .0001", .0005" | .00002", .00005", .0001", .0005" | .0001", .0005" |
| Error limit | µm | ± 10 | ± 14 | ± 10 | ± 14 | ± 10 | ± 14 | ± 10 | ± 14 |
| Error limit in partial measuring range | µm | ± 1 | | ± 1 | | ± 1 | | ± 1 | |
| Partial measuring range | mm | ± 0.199 | | ± 0.199 | | ± 0.199 | | ± 0.199 | |
| Standard | | Factory standard | | | | | | | |
| Measuring force | N | 0.8 – 1.1 | | | | | | | |

| Order no. | a | Mounting shaft | Mounting shaft |
|-----------|----|----------------|----------------|
| | mm | inch | mm |
| 2033091 | 17 | 0.375 | |
| 2033092 | 17 | 0.375 | |
| 2033093 | 38 | 0.375 | |
| 2033094 | 38 | 0.375 | |
| 2033095 | 17 | | 8 |
| 2033096 | 17 | | 8 |
| 2033097 | 38 | | 8 |
| 2033098 | 38 | | 8 |

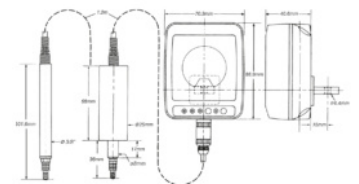

ACCESSORIES

| Order no. | Description | Type |
|-----------|--|-------------|
| 2201628 | Adapter - T-bracket, d = .375" | AAD-91 |
| 2208615 | Adapter - rack bracket, for Maxµm III transducer probes, d = .375" | EAD-1007-W1 |
| 2208616 | Adapter - rack bracket, for Maxµm III transducer probes, d = 8 mm | EAD-1007-W2 |
| 2236895 | Mounting block for back panel with rack | |

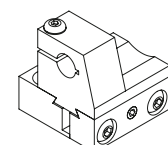

EAD-1007-W1;
EAD-1007-W2

Millimes Maxµm III

Digital probe

FEATURES

- Maxµm transducers are available as replacement parts - refer to part price list for part numbers and pricing
- Maxµm III remote indicating units are sold without digital transducer
- Any digital transducer may be used with a Maxµm III remote indicating unit
- For alternate cable lengths, extension cables or special indicator options - call Mahr's Technical Assistance Group
- **Software:** MarCom Professional free download: www.mahr.com/marcom (only for Mahr data cables and wireless systems with USB and RS-232 interface)



TECHNICAL DATA

| Order no. | 2033099 | |
|--|------------------|----------------------------------|
| Type | Maxµm III | |
| Measuring range | mm | ± 1.00 |
| Measuring range | inch | ± .040" |
| Resolution | mm | 0.0005, 0.001, 0.005 |
| Resolution | inch | .00002", .00005", .0001", .0005" |
| Error limit | µm | ± 10 |
| Error limit in partial measuring range | µm | ± 1 |
| Partial measuring range | mm | ± 0.199 |
| Standard | Factory standard | |
| Measuring force | N | 0.8 - 1.1 |

| Order no. | a | Mounting shaft |
|-----------|------|----------------|
| | mm | inch |
| 2033099 | 82.5 | 0.375 |

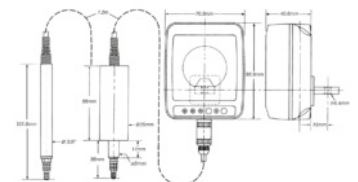

ACCESSORIES

| Order no. | Description | Type |
|-----------|--|-------------|
| 2201628 | Adapter - T-bracket, d = .375" | AAD-91 |
| 2208615 | Adapter - rack bracket, for Maxµm III transducer probes, d = .375" | EAD-1007-W1 |
| 2208616 | Adapter - rack bracket, for Maxµm III transducer probes, d = 8 mm | EAD-1007-W2 |
| 2236895 | Mounting block for back panel with rack | |

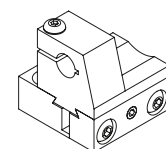

EAD-1007-W1;
EAD-1007-W2

Millimes Maxµm III

Inductive digital comparator



FUNCTIONS

- RESET (set display to zero)
- mm/inch
- Reversal of counting direction
- RANGE (switch the measuring range and resolution)
- ABS (reference to the electrical zero point)
- TOL (enter tolerance limit values)
- MAX/MIN (memory for searching the reversal point)
- MAX-MIN (for testing flatness and concentricity)
- HOLD (storage of measured values)

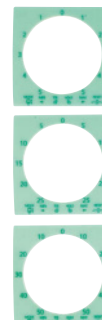

FEATURES

- Large, high contrast digital, analog and fan display for better readability while testing flatness and concentricity as well as for searching the reversal point in bores
- Interchangeable dials
- Inductive absolute measuring system
- Metal cast housing with robust buttons
- **Software:** MarCom Professional free download: www.mahr.com/marcom (only for Mahr data cables and wireless systems with USB and RS-232 interface)
- **Energy supply:** battery life approx. 4000 hrs.
- **Package contains:** interchangeable dials, battery, instruction manual

TECHNICAL DATA

| Order no. | 2033121 | 2033122 | 2033123 | 2033124 | 2033125 | 2033126 | 2033127 | 2033128 | | |
|--|------------------|----------------------------------|----------------|----------------------------------|----------------|----------------------------------|----------------|----------------------------------|----------------|--|
| Type | Maxµm III | | | | | | | | | |
| Measuring range | mm | ±1 | ±1.99 | ±1 | ±1.99 | ±1 | ±1.99 | ±1 | ±1.99 | |
| Measuring range | inch | ±.040" | ±.100" | ±.040" | ±.100" | ±.040" | ±.100" | ±.040" | ±.100" | |
| Resolution | mm | 0.0005, 0.001, 0.005 | 0.001, 0.005 | 0.0005, 0.001, 0.005 | 0.001, 0.005 | 0.0005, 0.001, 0.005 | 0.001, 0.005 | 0.0005, 0.001, 0.005 | 0.001, 0.005 | |
| Resolution | inch | .00002", .00005", .0001", .0005" | .0001", .0005" | .00002", .00005", .0001", .0005" | .0001", .0005" | .00002", .00005", .0001", .0005" | .0001", .0005" | .00002", .00005", .0001", .0005" | .0001", .0005" | |
| Error limit | µm | ± 10 | ± 14 | ± 10 | ± 14 | ± 10 | ± 14 | ± 10 | ± 14 | |
| Error limit in partial measuring range | µm | ± 1 | | ± 1 | | ± 1 | | ± 1 | | |
| Partial measuring range | mm | ± 0.199 | | ± 0.199 | | ± 0.199 | | ± 0.199 | | |
| Standard | Factory standard | | | | | | | | | |
| Free stroke | mm | 0.8 | 1.3 | 0.8 | 1.3 | 0.8 | 1.3 | 0.8 | 1.3 | |
| Measuring force | N | 0.8 – 1.1 | | | | | | | | |
| Range of analog display | mm | ± 5, ± 25, ± 50 | ± 25, ± 50 | ± 5, ± 25, ± 50 | ± 25, ± 50 | ± 5, ± 25, ± 50 | ± 25, ± 50 | ± 5, ± 25, ± 50 | ± 25, ± 50 | |
| IP protection category | IP 54 | | | | | | | | | |
| Data interface | RS-232C, USB | | | | | | | | | |

| Order no. | a | b | c | Mounting shaft |
|-----------|----|----|------|----------------|
| | mm | mm | mm | mm |
| 2033121 | 17 | 36 | 63.5 | |
| 2033122 | 22 | 47 | 73 | |
| 2033123 | 38 | 57 | 84.6 | |
| 2033124 | 38 | 57 | 84.6 | |
| 2033125 | 17 | 36 | 63.5 | 8 |
| 2033126 | 22 | 47 | 73 | 8 |
| 2033127 | 38 | 57 | 84.6 | 8 |
| 2033128 | 38 | 57 | 84.6 | 8 |

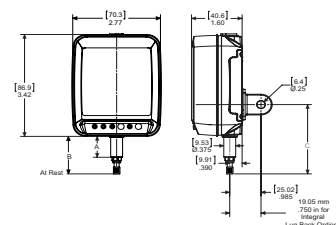

Millimes Maxum III

Inductive digital comparator

ACCESSORIES

| Order no. | Description | Type |
|-----------|--|-------------|
| 2239138 | Battery for Maxum III type CR 123A | |
| 2209094 | Lifting lever, left | EAS-1903 |
| 2210406 | Right angle attachment - spring type ($\pm .187''$ range) | EAT-1034-W1 |
| 2210407 | Right angle attachment - spring type ($\pm .060''$ range) | EAT-1035-W1 |
| 2210551 | Back panel with rack | EBK-1005 |
| 2236895 | Mounting block for back panel with rack | |
| 2210552 | Back panel with eyelets | EBK-1006 |
| 2210553 | Back panel with adjustable holder | EBK-1007 |
| 2212877 | Dust cover | ECV-1307-W1 |
| 2217907 | Spare screws for back panels | ESW-1252 |
| 2239037 | Interface adapter with data cable Digimatic (2 m) (E2) | |
| 2239038 | Data connection cable RS232C (2 m) (E2) | |
| 2200362 | Foot switch for send data (Maxum) or dynamic reset/zeroing (832), 1.5 m / 5 ft cable | 300-50 |
| 2239040 | Set of 3 inch and 3 metric scale overlay | |
| 2240547 | Maxum III, unlock setup and unlock calibration key, remove (E2) | |
| 2209924 | Hand switch for Hold/Reset | EAS-2867 |
| 2209925 | Foot switch for Hold/Reset | EAS-2868 |
| 2212428 | USB data cable for Maxum III (2 m) (E1) | |

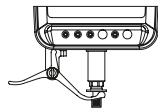

EAS-1903

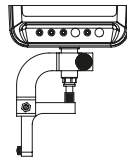

EAT-1034-W1;
EAT-1035-W1

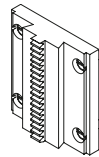

EBK-1005

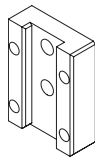

EBK-1007

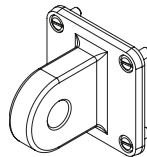

EBK-1006

Millimes Maxµm III

Inductive digital comparator



FUNCTIONS

- RESET (set display to zero)
- mm/inch
- Reversal of counting direction
- RANGE (switch the measuring range and resolution)
- ABS (reference to the electrical zero point)
- TOL (enter tolerance limit values)
- MAX/MIN (memory for searching the reversal point)
- MAX-MIN (for testing flatness and concentricity)
- HOLD (storage of measured values)

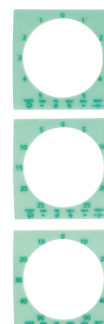

FEATURES

- Large, high contrast digital, analog and fan display for better readability while testing flatness and concentricity as well as for searching the reversal point in bores
- Interchangeable dials
- Inductive absolute measuring system
- Metal cast housing with robust buttons
- **Software:** MarCom Professional free download: www.mahr.com/marcom (only for Mahr data cables and wireless systems with USB and RS-232 interface)
- **Energy supply:** battery life approx. 4000 hrs.
- **Package contains:** interchangeable dials, battery, instruction manual

TECHNICAL DATA

| Order no. | 2033111 | 2033112 | 2033113 | 2033114 | 2033115 | 2033116 | 2033117 | 2033118 | | |
|--|-------------------------|----------------------------------|----------------|----------------------------------|----------------|----------------------------------|----------------|----------------------------------|----------------|--|
| Type | Maxµm III | | | | | | | | | |
| Measuring range | mm | ±1 | ±1.99 | ±1 | ±1.99 | ±1 | ±1.99 | ±1 | ±1.99 | |
| Measuring range | inch | ±.040" | ±.100" | ±.040" | ±.100" | ±.040" | ±.100" | ±.040" | ±.100" | |
| Resolution | mm | 0.0005, 0.001, 0.005 | 0.001, 0.005 | 0.0005, 0.001, 0.005 | 0.001, 0.005 | 0.0005, 0.001, 0.005 | 0.001, 0.005 | 0.0005, 0.001, 0.005 | 0.001, 0.005 | |
| Resolution | inch | .00002", .00005", .0001", .0005" | .0001", .0005" | .00002", .00005", .0001", .0005" | .0001", .0005" | .00002", .00005", .0001", .0005" | .0001", .0005" | .00002", .00005", .0001", .0005" | .0001", .0005" | |
| Error limit | µm | ± 10 | ± 14 | ± 10 | ± 14 | ± 10 | ± 14 | ± 10 | ± 14 | |
| Error limit in partial measuring range | µm | ± 1 | | ± 1 | | ± 1 | | ± 1 | | |
| Partial measuring range | mm | ± 0.199 | | ± 0.199 | | ± 0.199 | | ± 0.199 | | |
| Standard | Factory standard | | | | | | | | | |
| Free stroke | mm | 0.8 | 1.3 | 0.8 | 1.3 | 0.8 | 1.3 | 0.8 | 1.3 | |
| Measuring force | N | 0.8 – 1.1 | | | | | | | | |
| Range of analog display | mm | ± 5, ± 25, ± 50 | ± 25, ± 50 | ± 5, ± 25, ± 50 | ± 25, ± 50 | ± 5, ± 25, ± 50 | ± 25, ± 50 | ± 5, ± 25, ± 50 | ± 25, ± 50 | |
| IP protection category | IP 54 | | | | | | | | | |
| Data interface | RS-232C, Digimatic, USB | | | | | | | | | |

| Order no. | a | b | c | Mounting shaft |
|-----------|----|----|------|----------------|
| | mm | mm | mm | mm |
| 2033111 | 17 | 36 | 63.5 | |
| 2033112 | 22 | 47 | 73 | |
| 2033113 | 38 | 57 | 84.6 | |
| 2033114 | 38 | 57 | 84.6 | |
| 2033115 | 17 | 36 | 63.5 | 8 |
| 2033116 | 22 | 47 | 73 | 8 |
| 2033117 | 38 | 57 | 84.6 | 8 |
| 2033118 | 38 | 57 | 84.6 | 8 |

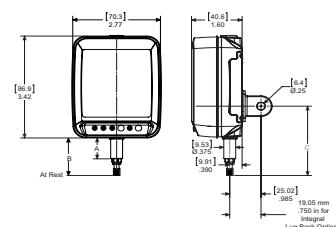

Millimes Maxµm III

Inductive digital comparator

ACCESSORIES

| Order no. | Description | Type |
|-----------|--|-------------|
| 2239138 | Battery for Maxµm III type CR 123A | |
| 2209094 | Lifting lever, left | EAS-1903 |
| 2210406 | Right angle attachment - spring type (\pm .187" range) | EAT-1034-W1 |
| 2210407 | Right angle attachment - spring type (\pm .060" range) | EAT-1035-W1 |
| 2210551 | Back panel with rack | EBK-1005 |
| 2236895 | Mounting block for back panel with rack | |
| 2210552 | Back panel with eyelets | EBK-1006 |
| 2210553 | Back panel with adjustable holder | EBK-1007 |
| 2212877 | Dust cover | ECV-1307-W1 |
| 2217907 | Spare screws for back panels | ESW-1252 |
| 2239035 | Interface adapter with data cable Digimatic (2 m) (D, E1) | |
| 2239036 | Data cable RS232C (2 m) (D, E1) | |
| 2121428 | USB data cable for Maxµm III (2 m) (E1) | |
| 2200362 | Foot switch for send data (Maxµm) or dynamic reset/zeroing (832), 1.5 m / 5 ft cable | 300-50 |
| 2240545 | Maxµm III, unlock setup and unlock calibration key, (D, E1) | |
| 2239040 | Set of 3 inch and 3 metric scale overlay | |

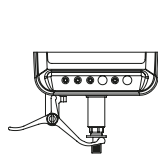

EAS-1903

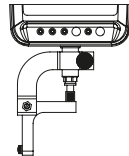

EAT-1034-W1;
EAT-1035-W1

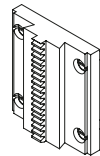

EBK-1005

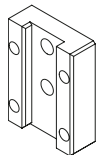

EBK-1007

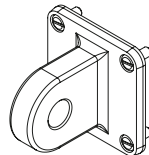

EBK-1006

Millimes Maxµm III

Inductive digital comparator



FUNCTIONS

- RESET (set display to zero)
- mm/inch
- Reversal of counting direction
- RANGE (switch the measuring range and resolution)
- ABS (reference to the electrical zero point)
- TOL (enter tolerance limit values)
- MAX/MIN (memory for searching the reversal point)
- MAX-MIN (for testing flatness and concentricity)
- HOLD (storage of measured values)

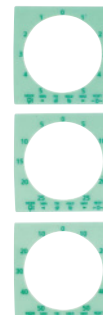

FEATURES

- Large, high contrast digital, analog and fan display for better readability while testing flatness and concentricity as well as for searching the reversal point in bores
- Interchangeable dials
- Inductive absolute measuring system
- Metal cast housing with robust buttons
- **Software:** MarCom Professional free download: www.mahr.com/marcom (only for Mahr data cables and wireless systems with USB and RS-232 interface)
- **Energy supply:** Battery life approx. 4000 hrs.
- **Package contains:** interchangeable dials, battery, instruction manual

TECHNICAL DATA

| Order no. | 2033101 | 2033102 | 2033103 | 2033104 | 2033105 | 2033106 | 2033107 | 2033108 | | |
|--|------------------|----------------------------------|----------------|----------------------------------|----------------|----------------------------------|----------------|----------------------------------|----------------|--|
| Type | Maxµm III | | | | | | | | | |
| Measuring range | mm | ±1 | ±1.99 | ±1 | ±1.99 | ±1 | ±1.99 | ±1 | ±1.99 | |
| Measuring range | inch | ±.040" | ±.100" | ±.040" | ±.100" | ±.040" | ±.100" | ±.040" | ±.100" | |
| Resolution | mm | 0.0005, 0.001, 0.005 | 0.001, 0.005 | 0.0005, 0.001, 0.005 | 0.001, 0.005 | 0.0005, 0.001, 0.005 | 0.001, 0.005 | 0.0005, 0.001, 0.005 | 0.001, 0.005 | |
| Resolution | inch | .00002", .00005", .0001", .0005" | .0001", .0005" | .00002", .00005", .0001", .0005" | .0001", .0005" | .00002", .00005", .0001", .0005" | .0001", .0005" | .00002", .00005", .0001", .0005" | .0001", .0005" | |
| Error limit | µm | ±10 | ±14 | ±10 | ±14 | ±10 | ±14 | ±10 | ±14 | |
| Error limit in partial measuring range | µm | ±1 | | ±1 | | ±1 | | ±1 | | |
| Partial measuring range | mm | ±0.199 | | ±0.199 | | ±0.199 | | ±0.199 | | |
| Standard | Factory standard | | | | | | | | | |
| Free stroke | mm | 0.8 | 1.3 | 0.8 | 1.3 | 0.8 | 1.3 | 0.8 | 1.3 | |
| Measuring force | N | 0.8 – 1.1 | | | | | | | | |
| Range of analog display | mm | ±5, ±25, ±50 | ±25, ±50 | ±5, ±25, ±50 | ±25, ±50 | ±5, ±25, ±50 | ±25, ±50 | ±5, ±25, ±50 | ±25, ±50 | |
| IP protection category | IP 54 | | | | | | | | | |

| Order no. | a | b | c | Mounting shaft |
|-----------|----|----|------|----------------|
| | mm | mm | mm | mm |
| 2033101 | 17 | 36 | 63.5 | |
| 2033102 | 22 | 47 | 73 | |
| 2033103 | 38 | 57 | 84.6 | |
| 2033104 | 38 | 57 | 84.6 | |
| 2033105 | 17 | 36 | 63.5 | 8 |
| 2033106 | 22 | 47 | 73 | 8 |
| 2033107 | 38 | 57 | 84.6 | 8 |
| 2033108 | 38 | 57 | 84.6 | 8 |

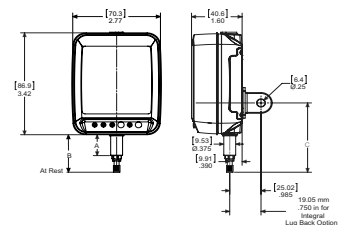

Millimes Maxµm III

Inductive digital comparator

ACCESSORIES

| Order no. | Description | Type |
|-----------|--|-------------|
| 2239138 | Battery for Maxµm III type CR 123A | |
| 2209094 | Lifting lever, left | EAS-1903 |
| 2210406 | Right angle attachment - spring type ($\pm .187''$ range) | EAT-1034-W1 |
| 2210407 | Right angle attachment - spring type ($\pm .060''$ range) | EAT-1035-W1 |
| 2210551 | Back panel with rack | EBK-1005 |
| 2236895 | Mounting block for back panel with rack | |
| 2210552 | Back panel with eyelets | EBK-1006 |
| 2210553 | Back panel with adjustable holder | EBK-1007 |
| 2212877 | Dust cover | ECV-1307-W1 |
| 2239040 | Set of 3 inch and 3 metric scale overlay | |
| 2217907 | Spare screws for back panels | ESW-1252 |

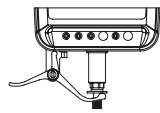

EAS-1903

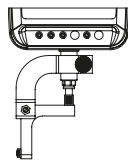

EAT-1034-W1;
EAT-1035-W1

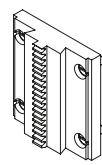

EBK-1005

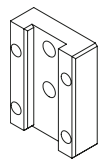

EBK-1007

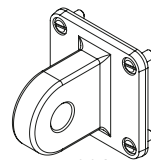

EBK-1006

FEATURES

- Large, high contrast dial face
- Adjustable tolerance markers
- Lockable fine adjustment screw
- Shockproof movement
- Mounting shank and measuring spindle are both made of hardened stainless steel
- Measuring spindle is mounted in a high precision ball guide for minimal hysteresis
- Resistant to lateral forces (side play) acting on the measuring spindle
- Maximum sensitivity and accuracy are ensured by the jeweled movement in conjunction with the precision gears and pinions
- Box type protective housing
- Constant measuring force
- Measuring spindle can be retracted with either a screw in cable release or with a lifting knob
- Package contains: case



TECHNICAL DATA

| Order no. | | 4334000 | 4334005 | 4334102 | 4334103 | 4335000 | 4335005 |
|----------------------------------|----|-----------|---------|------------------|-----------|---------|------------------|
| Type | | 1003 | 1003 T | 1002 | 1003 | 1002 | 1002 T |
| Measuring range | mm | ± 0.05 | | ± 0.03 | ± 0.05 | | ± 0.03 |
| Scale graduation value | µm | 1 | | 0.5 | 1 | | 0.5 |
| Figure on dial face | | 50-0-50 | | 25-0-25 | 50-0-50 | | 25-0-25 |
| Error limit G_e | µm | 1 | | 0.5 | 1 | | 0.5 |
| Error limit G_{ges} | µm | 1.2 | | 0.6 | 1.2 | | 0.6 |
| Error limit G_t | µm | 0.7 | | 0.4 | 0.7 | | 0.4 |
| Measuring value hysteresis f_u | µm | 0.5 | | 0.3 | 0.5 | | 0.3 |
| Repeatability f_w | µm | 0.5 | | 0.3 | 0.5 | | 0.3 |
| Standard | | DIN 879-1 | | Factory standard | DIN 879-1 | | Factory standard |
| Free stroke | mm | 2.8 | | | | | |
| Measuring force | N | 1 | | | | | |
| Scale diameter | mm | 50 | | | | | |
| Dial color | | Yellow | | White | | Yellow | |
| IP protection category | | IP 54 | | | | IP 54 | |

| Order no. | Mounting shaft |
|-----------|----------------|
| | mm |
| 4334000 | 8 |
| 4334005 | 8 |
| 4334102 | 8 |
| 4334103 | 8 |
| 4335000 | 8 |
| 4335005 | 8 |

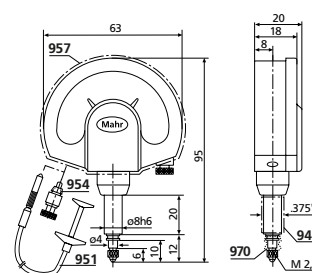

ACCESSORIES

| Order no. | Description | Type |
|-----------|--|------|
| 4310103 | Adapter bushing (.375" / 8 mm) | 940 |
| 4372000 | Cable release (250 mm) | 951 |
| 4372030 | Lifting knob | 954 |
| 4373030 | Splash guard cover | 957 |
| 4334786 | Rubber bellows | 970 |
| 4375002 | Lug back to mount on mounting shank 8h6 mm | 963 |

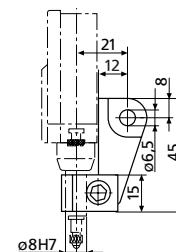

963

Millimess 1004 / 1004 T / 1003 XL / 1003 XLT

Dial comparator



FEATURES

- Large, high contrast dial face
- Adjustable tolerance markers
- Lockable fine adjustment screw
- Shockproof movement
- Mounting shank and measuring spindle are both made of hardened stainless steel
- Measuring spindle is mounted in a high precision ball guide for minimal hysteresis
- Resistant to lateral forces (side play) acting on the measuring spindle
- Maximum sensitivity and accuracy are ensured by the jeweled movement in conjunction with the precision gears and pinions
- Box type protective housing
- Constant measuring force
- Measuring spindle can be retracted with either a screw in cable release or with a lifting knob
- Package contains: case



TECHNICAL DATA

| Order no. | | 4333000 | 4333005 | 4334001 | 4334006 |
|----------------------------------|----|------------------|---------|---------|----------|
| Type | | 1004 | 1004 T | 1003 XL | 1003 XLT |
| Measuring range | mm | ± 0.13 | | | |
| Scale graduation value | µm | 5 | | 2 | |
| Figure on dial face | | 130–0–130 | | | |
| Error limit G_e | µm | 3.5 | | 2 | |
| Error limit G_{ges} | µm | 4 | | 2.4 | |
| Error limit G_t | µm | 3 | | 1.4 | |
| Measuring value hysteresis f_u | µm | 1 | | | |
| Repeatability f_w | µm | 1 | | | |
| Standard | | Factory standard | | | |
| Free stroke | mm | 2.5 | | | |
| Measuring force | N | 1 | | | |
| Scale diameter | mm | 50 | | | |
| Dial color | | White | | Yellow | |
| IP protection category | | IP 54 | | IP 54 | |

| Order no. | Mounting shaft |
|-----------|----------------|
| | mm |
| 4333000 | 8 |
| 4333005 | 8 |
| 4334001 | 8 |
| 4334006 | 8 |

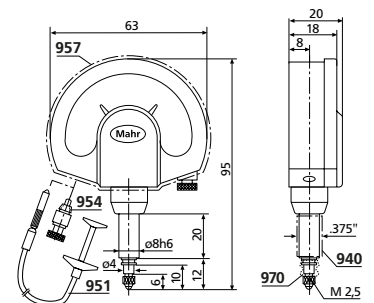

ACCESSORIES

| Order no. | Description | Type |
|-----------|--|------|
| 4310103 | Adapter bushing (.375" / 8 mm) | 940 |
| 4372000 | Cable release (250 mm) | 951 |
| 4372030 | Lifting knob | 954 |
| 4373030 | Splash guard cover | 957 |
| 4334786 | Rubber bellows | 970 |
| 4375002 | Lug back to mount on mounting shank 8h6 mm | 963 |

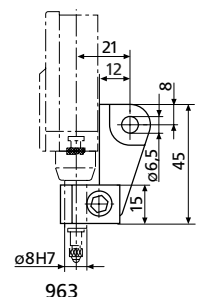

FEATURES

- Large, high contrast dial face
- Adjustable tolerance markers
- Lockable fine adjustment screw
- Shockproof movement
- Mounting shank and measuring spindle are both made of hardened stainless steel
- Measuring spindle is mounted in a high precision ball guide for minimal hysteresis
- Resistant to lateral forces (side play) acting on the measuring spindle
- Maximum sensitivity and accuracy are ensured by the jeweled movement in conjunction with the precision gears and pinions
- Box type protective housing
- Constant measuring force
- Measuring spindle can be retracted with either a screw in cable release or with a lifting knob
- Package contains: case

Applications:

- Models with reduced or increased measuring force
- Lower measuring force is required e.g. for measurements on thin-walled or soft materials or sensitive surfaces
- Increased measuring force is required to e.g. improve the repeatability of extended
- to improve the repeatability of comparative measuring devices



TECHNICAL DATA

| Order no. | 4334075 4334070 4334050 4334076 4334071 4334010 4334011 | | | | | | | |
|----------------------------------|---|--------|-----|-----|-----|-----|------------------|---|
| Type | 1003 | | | | | | | |
| Measuring range | mm | ± 0.05 | | | | | | |
| Scale graduation value | μm | 1 | | | | | | |
| Figure on dial face | 50–0–50 | | | | | | | |
| Error limit G_e | μm | 1 | | | | | | |
| Error limit G_{ges} | μm | 1.2 | | | | | | |
| Error limit G_t | μm | 0.7 | | | | | | |
| Measuring value hysteresis f_u | μm | 0.5 | | | | | | |
| Repeatability f_w | μm | 0.5 | | | | | | |
| Standard | DIN 879–1 | | | | | | Factory standard | |
| Free stroke | mm | 2.8 | | | | | | |
| Measuring force | N | 0.3 | 0,4 | 0.5 | 0.6 | 0.7 | 2 | 3 |
| Scale diameter | mm | 50 | | | | | | |
| Dial color | Yellow | | | | | | | |

| Order no. | Mounting shaft |
|-----------|----------------|
| | mm |
| 4334075 | 8 |
| 4334070 | 8 |
| 4334050 | 8 |
| 4334076 | 8 |
| 4334071 | 8 |
| 4334010 | 8 |
| 4334011 | 8 |

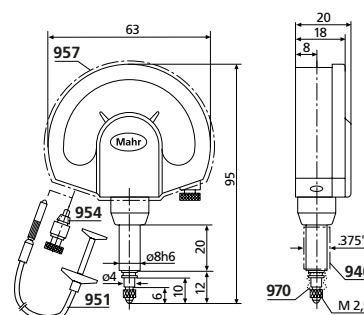

ACCESSORIES

| Order no. | Description | Type |
|-----------|--|------|
| 4310103 | Adapter bushing (.375" / 8 mm) | 940 |
| 4372000 | Cable release (250 mm) | 951 |
| 4372030 | Lifting knob | 954 |
| 4373030 | Splash guard cover | 957 |
| 4334786 | Rubber bellows | 970 |
| 4375002 | Lug back to mount on mounting shank 8h6 mm | 963 |

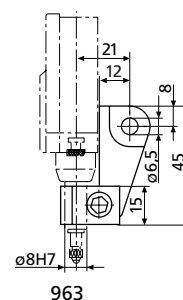

Millimess 1000 A / 1000 B

Dial comparator

FEATURES

- Large, high contrast dial face
- Adjustable tolerance markers
- Lockable fine adjustment screw
- Shockproof movement
- Mounting shank and measuring spindle are both made of hardened stainless steel
- Measuring spindle is mounted in a high precision ball guide for minimal hysteresis
- Resistant to lateral forces (side play) acting on the measuring spindle
- Maximum sensitivity and accuracy are ensured by the jeweled movement in conjunction with the precision gears and pinions
- Box type protective housing
- Constant measuring force
- Measuring spindle can be retracted with either a screw in cable release or with a lifting knob
- **Package contains:** cable release, case

Applications:

- Very clear, reliable and fatigue-free readings due to extra-large display
- Ideal for test stations at which high volume production parts are measured or where the display can only be read from a distance
- For use in a stable measuring table. We recommend: MarStand 824 GT measuring table
- M2.5 thread on end of measuring pin for optional standard anvils



TECHNICAL DATA

| Order no. | 4338100 | 4339100 |
|----------------------------------|------------------|---------|
| Type | 1000 A | 1000 B |
| Measuring range | mm ± 0.12 | ± 0.05 |
| Scale graduation value | µm | 1 |
| Figure on dial face | 120–0–120 | 50–0–50 |
| Error limit G_e | µm | 1.5 |
| Error limit G_{ges} | µm | 2 |
| Error limit G_t | µm | 0.7 |
| Measuring value hysteresis f_u | µm | 1 |
| Repeatability f_w | µm | 0.5 |
| Standard | Factory standard | |
| Free stroke | mm | 4 |
| Measuring force | N | 3.5 |
| Scale diameter | mm | 110 |
| Dial color | Yellow | |

| Order no. | Mounting shaft |
|-----------|----------------|
| | mm |
| 4338100 | 28 |
| 4339100 | 28 |

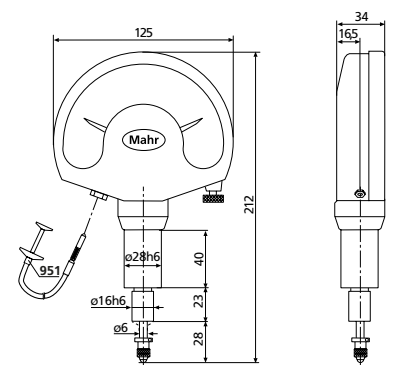

ACCESSORIES

| Order no. | Description | Type |
|-----------|-----------------------------|-------|
| 4362001 | Contact point, steel ball | 921 |
| 4362002 | Contact point, ruby ball | 921 R |
| 4372000 | Cable release (250 mm) | 951 |
| 4338008 | Rubber bellows for 1000 A/B | |

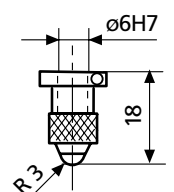

921/921R

FEATURES

- Large, high contrast dial face
- Adjustable tolerance markers
- Lockable fine adjustment screw
- Shockproof movement
- Mounting shank and measuring spindle are both made of hardened stainless steel
- Measuring spindle is mounted in a high precision ball guide for minimal hysteresis
- Resistant to lateral forces (side play) acting on the measuring spindle
- Maximum sensitivity and accuracy are ensured by the jeweled movement in conjunction with the precision gears and pinions
- Box type protective housing
- Constant measuring force
- Measuring spindle can be retracted with either a screw in cable release or with a lifting knob
- Package contains: case



TECHNICAL DATA

| Order no. | 4332000 | | 4332005 | |
|----------------------------------|------------------|--------|---------|-------|
| Type | 1010 | | 1010 T | |
| Measuring range | mm | ± 0.25 | | |
| Readings | 0.01 | | | |
| Figure on dial face | 25–0–25 | | | |
| Error limit G_e | μm | 7 | | |
| Error limit G_{ges} | μm | 8 | | |
| Error limit G_t | μm | 4 | | |
| Measuring value hysteresis f_u | μm | 2 | | |
| Repeatability f_w | μm | 2 | | |
| Standard | Factory standard | | | |
| Free stroke | mm | 2.5 | | |
| Measuring force | N | 1 | | |
| Scale diameter | mm | 50 | | |
| Dial color | White | | | |
| IP protection category | | | | IP 54 |

| Order no. | Mounting shaft |
|-----------|----------------|
| 4332000 | 8 mm |
| 4332005 | 8 mm |

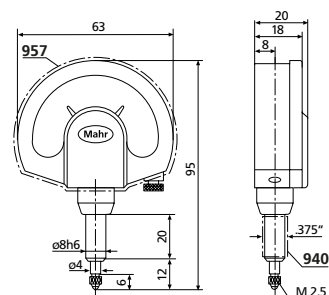

ACCESSORIES

| Order no. | Description | Type |
|-----------|--|------|
| 4310103 | Adapter bushing (.375" / 8 mm) | 940 |
| 4372000 | Cable release (250 mm) | 951 |
| 4372030 | Lifting knob | 954 |
| 4373030 | Splash guard cover | 957 |
| 4375002 | Lug back to mount on mounting shank 8h6 mm | 963 |

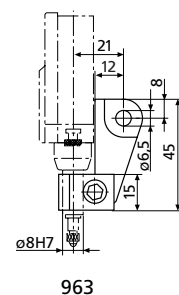

FEATURES

- Large, high contrast dial face
- Adjustable tolerance markers
- Lockable fine adjustment screw
- Shockproof movement
- Mounting shank and measuring spindle are both made of hardened stainless steel
- Measuring spindle is mounted in a high precision ball guide for minimal hysteresis
- Resistant to lateral forces (side play) acting on the measuring spindle
- Maximum sensitivity and accuracy are ensured by the jeweled movement in conjunction with the precision gears and pinions
- Box type protective housing
- Constant measuring force
- Measuring spindle can be retracted with either a screw in cable release or with a lifting knob
- **Package contains:** case, adapter bush 940, 8 mm to 3/8"



TECHNICAL DATA

| Order no. | 4332900 | 4332905 | 4333900 | 4333905 | 4334900 | 4334905 | 4335900 | 4335905 |
|----------------------------------|---------|------------------|---------|---------------|---------|---------------|---------|---------------|
| Type | 1010 Z | 1010 ZT | 1004 Z | 1004 ZT | 1003 Z | 1003 ZT | 1002 Z | 1002 ZT |
| Measuring range | inch | ± .0100" | | ± .0050" | | ± .0020" | | ± .0010" |
| Readings | inch | 0.0005 | | 0.0001 | | 0.00005 | | 0.00002 |
| Figure on dial face | | .01"—0—.01" | | .005"—0—.005" | | .002"—0—.002" | | .001"—0—.001" |
| Error limit G_e | inch | 0,00035 | | 0,0001 | | 0,00005 | | 0,00002 |
| Error limit G_{ges} | inch | 0,0004 | | 0,00012 | | 0,00006 | | 0,00003 |
| Error limit G_t | inch | 0,000250 | | 0,000050 | | 0,000035 | | 0,000014 |
| Measuring value hysteresis f_u | inch | 0,0001 | | 0,00003 | | | | 0,00001 |
| Repeatability f_w | inch | 0,0001 | | 0,0000 | | | | |
| Standard | | Factory standard | | | | | | |
| Free stroke | mm | 2.5 | | | | | | |
| Measuring force | N | 1 | | | | | | |
| Scale diameter | mm | 50 | | | | | | |
| Dial color | | White | | | | | | |
| IP protection category | | IP 54 | | IP 54 | | IP 54 | | IP 54 |

| Order no. | Mounting shaft | Mounting shaft |
|-----------|----------------|----------------|
| | inch | mm |
| 4332900 | 0.375 | 8 |
| 4332905 | 0.375 | 8 |
| 4333900 | 0.375 | 8 |
| 4333905 | 0.375 | 8 |
| 4334900 | 0.375 | 8 |
| 4334905 | 0.375 | 8 |
| 4335900 | 0.375 | 8 |
| 4335905 | 0.375 | 8 |

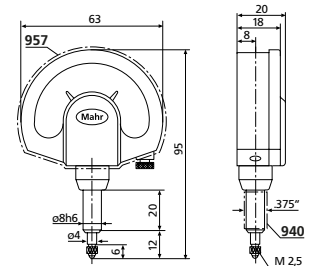

ACCESSORIES

| Order no. | Description | Type |
|-----------|--|------|
| 4310103 | Adapter bushing (.375" / 8 mm) | 940 |
| 4372000 | Cable release (250 mm) | 951 |
| 4372030 | Lifting knob | 954 |
| 4373030 | Splash guard cover | 957 |
| 4375002 | Lug back to mount on mounting shank 8h6 mm | 963 |
| 4334786 | Rubber bellows | 970 |

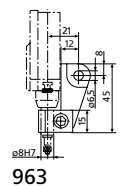

Millimar | Electrical and pneumatic length measuring instruments

The requirements for electrical length measuring instruments are just as varied as their applications. Excellent reliability, precision and simple operation are necessary. Millimar measuring instruments fulfill all these requirements. These products are rugged, versatile and attractively priced.



| | |
|--|------------|
| Overview - Millimar product family | 214 |
| Millimar C 1200 T / C 1200 M / C 1202 Compact length measuring device | 218 |
| Millimar S 1840 M / S 1840 F / S 1840 PE/F Compact length measuring device | 220 |
| Millimar C 1750 PC Measuring computer | 222 |
| Millimar Cockpit 13 Measuring software | 223 |
| Millimar N 1700 modules Evaluating measuring sensors | 224 |
| Millimar μDimensionair II® Mobile pneumatic length measuring device | 231 |
| Overview - Millimar inductive measuring probes | 232 |
| Millimar P2000 series Inductive probes | 234 |
| Millimar P1300 series Inductive probes | 244 |
| Millimar P 1512 V / P 1530 V Incremental probes | 252 |
| Overview - Millimar air gage metrology | 253 |
| Millimar DP50 / DP20 / DP60 Air plug gages | 255 |
| Millimar DR50 / DR20 2-jet air ring gages | 260 |
| Millimar DR50-3 / DR20-3 3-jet air ring gages | 261 |
| Millimar AAT-19 / AAT-20 Single jet probe | 262 |
| Millimar 6105 N Setting rings | 263 |
| Millimar 6107 S Highly accurate setting rings | 264 |
| Millimar 6400 Setting plugs | 265 |
| Overview - Millimar standard elements | 266 |

Flexible measurement in production

with the new generation of the Millimar family

The components of the Millimar series are optimized to make measuring processes in production as simple and precise as possible. This is achieved primarily through the individual composition of the measuring devices – because every production environment brings with it different focal points, spatial characteristics or measurement-related requirements.

Millimar products are specially developed for these kinds of requirements of modern quality assurance. Here, the focus is primarily on simplifying handling, accelerating processes and, at the same time, integrating fully into complex working environments.

- Flexible and modular product combinations for solving customer-specific measurement tasks
- Different modules for different measurement requirements
- Wide selection of measurement sensors enables the performance of diverse measurement tasks
- Use in a wide range of applications
- Realization of highly dynamic measurements due to extremely high data transmission rate

Millimar | Evaluation units



C 1200



N1700 modules



Cockpit Software

Millimar | Inductive probes



P1300 M



P2004 M

Single measurement with one probe

- Indicating instrument instantly displays the measured value.
- Used for all kinds of direct measurements on cylindrical and flat workpieces.
- Applied in the same way as with digital / dial indicators, digital / dial comparators or test indicators.

Thickness measurement

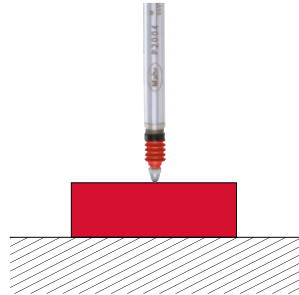

Sum measurement with 2 probes

Indicates the sum of deviation (total composite error) acquired from 2 probes irrespective of the form, support and concentricity deviation.

Thickness measurement

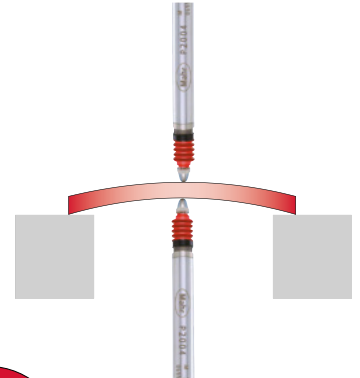

Radial runout

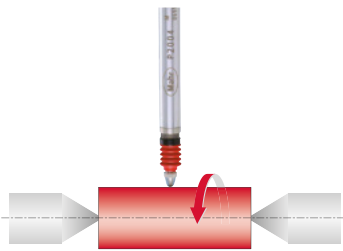

Axial runout

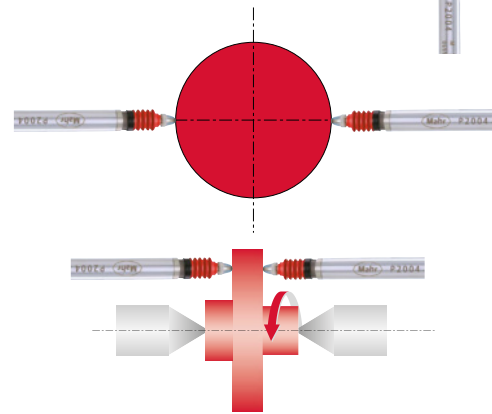
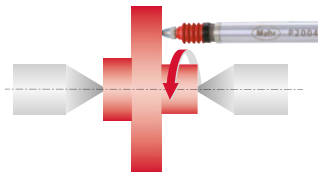

Difference measurement with 2 probes

Shows the difference between the measured values acquired by 2 probes irrespective of the absolute dimension of the test piece. This is particularly suitable for dimensional comparison of two test points.

Form measurement of wedges, cones

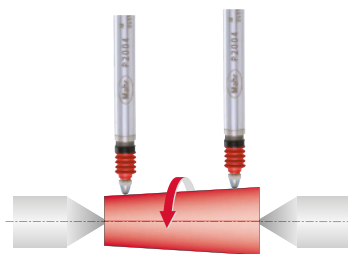

Height difference between 2 steps

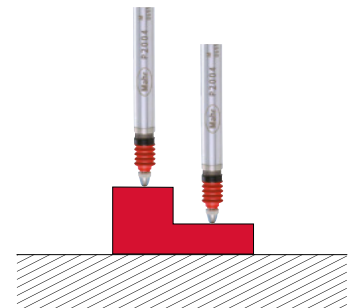

Perpendicularity measurement

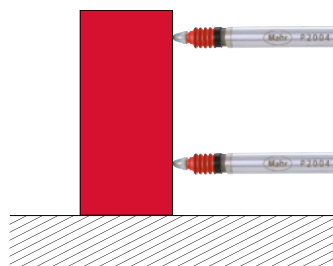

Concentricity measurement on 2 shaft diameters

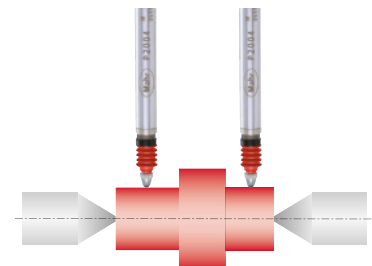

Flexible evaluation and display anywhere

The Millimar C 1202 compact instrument is versatile and suitable for use with a variety of sensors.

The Millimar C 1202 represents the next generation of multichannel compact instruments for length metrology. Due to its sophisticated features such as the tilting easy-to-read display, clear menu navigation and flexible representation of measuring values, it offers maximum ergonomics and user-friendliness. Combine with an easy to change module from the N 1700 series to create just the right measuring instrument for your measuring task. Thanks to its wide range of functions, the Millimar C 1202 is extremely versatile. It can be used to tackle a multitude of measuring tasks, e.g. static and dynamic measurements as well as cone calculations. Moreover, depending on the module, measuring probes by other manufacturers may also be compatible, which will reduce your costs.

Tilting display

Measuring values can be read clearly and effortlessly from all viewing angles. The display also features a backlight.

Sturdy plastic housing

As the Millimar C 1202 is impervious to external influences, it is ideal for use in production.

Interchangeable modules

The Millimar C 1202 can be easily converted to handle different measuring tasks.

Configuring C 1202

Possible combinations with N 1700 modules

N 1702 M/M-HR/T/U



N 1702 VPP



N 1701 PF/PM



End plate included in delivery of Millimar C 1202



1x N 170x module or 2x N 1701 PF/PM



Extension rail, 2x N 1701 PF/PM



C 1202

Millimar C 1202

9

Different N 1700 modules can be combined with Millimar C 1202



Interpret measuring results with ease

The high contrast color display provides a clear presentation of the measuring results.

Large keys

The Millimar C 1202 can also be reliably operated with gloves. Even dirt does not impede its function.



Advantages

- Three features can be displayed at the same time – for even more static and dynamic measuring tasks
- Two independent inputs via N 1700 module for the optional connection of measuring probes and pneumatic transducers
- Interchangeable modules for flexibility and compatibility
- Digimatic and USB ports for easy connection to data collection systems and evaluation software
- Programmable measuring sequences for greater productivity and reliability

Flexible setup options

Users can position the instrument on the table or fix it to the wall.

Millimar C 1200 T / C 1200 M

Compact amplifier



FUNCTIONS

- ON/OFF
- mm/inch
- Reversal of counting direction
- Selectable measuring range
- MAX/MIN memory for searching the reversal point
- MAX-MIN for testing flatness and concentricity
- TOL (enter tolerance limit values)
- PRESET (for entering a numerical value)
- Selectable resolution
- Factor (adjustable)
- DATA (data transmission)
- Menu interlock



Millimar C 1200, now in 2 versions

- M for inductive probes with the compatibility M
- T for inductive probes with the compatibility T



FEATURES

- High-resolution, high-contrast color display
- Fully adjustable display for ideal viewing angle
- Extremely easy to operate
- Suitable for power source or battery operation
- Suitable for mobile use with battery operation
- Compact housing
- Suitable for wall mounting
- **Battery type:** 5 x LR6 (1.5V Mignon AA) possible
- **Package contains:** power source, instruction manual
- **Software:** MarCom Professional free download: www.mahr.com/marcom (only for Mahr data cables and wireless systems with USB and RS-232 interface)

TECHNICAL DATA

| Order no. | 5312011 | 5312012 |
|------------------------------|--|--|
| Type | C 1200 T | C 1200 M |
| Display | TFT color display, 110 mm (4.3"), 480 x 272 pixels | |
| Range of digital display | μm | ± 5000 |
| Range of digital display | inch | $\pm .19''$ |
| Range of analog display | μm | $\pm 5000, \pm 2000, \pm 1000, \pm 300, \pm 100, \pm 30, \pm 10, \pm 3$ |
| Range of analog display | inch | $\pm .19'', \pm .07'', \pm .03'', \pm .01'', \pm .003'', \pm .001'', \pm .0003'', \pm .0001''$ |
| Resolution | μm | 0.1 |
| Resolution | inch | .000005" |
| Scale graduation value | μm | 500, 200, 100, 20, 10, 2, 1, 0.2 |
| Scale graduation value | inch | .019", .007", .002", .001", .0002", .0001", .00002", .00001" |
| Probe inputs | 1 | |
| Compatibility | Tesa | Mahr |
| Measuring combination | +A, -A | |
| Features | 1 | |
| Dynamic functions | Max, Min, Max-Min | |
| Configuration | Keyboard | |
| Data transmission rate | Hz | 30 |
| Refresh rate | fps | 40 |
| Error limit, digital display | 0.3% (min. 0.2 μm) | |
| Error limit, analog display | 0.25% of the end scale value / 0.3% of the displayed value | |
| Data interface | Opto RS-232C, USB, Digimatic, wireless | |
| Energy supply | Power source, 230 V/115 V; 50/60 Hz, battery operation | |
| IP protection category | IP 42 | |

| Order no. | Width | Height | Depth |
|-----------|-------|--------|-------|
| | mm | mm | mm |
| 5312011 | 130 | 170 | 150 |
| 5312012 | 130 | 170 | 150 |

ACCESSORIES

| Order no. | Description | Type |
|-----------|---|----------|
| 4346023 | 2000 USB data connection cable USB (2 m) | 2000 USB |
| 4346021 | Interface adapter with data cable Digimatic (2 m) | 2000 d |
| 4346020 | Data connection cable RS232C (2 m) | 2000 r |
| 4102232 | 2000 e transmitter for e-Stick | 2000 e |
| 4102230 | e-Stick receiver | e-Stick |



Millimar C 1202

Compact amplifier



FUNCTIONS

- mm/inch
- TOL (Tolerance and Warning Limits Input)
- PRESET (for entering a numerical value)
- Mastering 1 and 2 point
- MAX/MIN memory for searching the reversal point
- MAX-MIN for testing flatness and concentricity
- HOLD (storage of measured values)
- Selectable resolution
- Factor (adjustable)
- Reversal of counting direction
- Control input programmable
- Measuring sequence with time control
- DATA (data transmission)
- Menu interlock

FEATURES

- Versatility for a wide range of measuring tasks
- N 1700 modules as measuring channels for inductive and incremental probes or for pneumatic measuring equipment
- High-resolution, high-contrast color display
- Fully adjustable display for ideal viewing angle
- Measurement values can be displayed in three ways: as a number, pointer or bar
- 1 –3 features can be displayed at once
- Extremely easy to operate
- Several measuring tasks can be stored on the memory card
- Compact housing
- Suitable for wall-mounting
- **Package contains:** power source, micro SD memory card, instruction manual, without N 1700 module (necessary optional accessory)
- **Software:** MarCom Professional free download: www.mahr.com/marcom (only for Mahr data cables and wireless systems with USB and RS-232 interface)



Applications:

Indicating instrument for precise length measurements

- For connecting different sensors by way of N1700 measuring modules
- For connecting up to 2 measuring sensors

Please note:

N1700 measuring modules are necessary additional accessories

TECHNICAL DATA

| Order no. | 5312025 | |
|------------------------------|---|--|
| Type | C 1202 | |
| Display | TFT color display, 110 mm (4.3"), 480 x 272 pixels | |
| Range of digital display | µm | ± 999 999.9 |
| Range of digital display | inch | ± 39" |
| Range of analog display | µm | ± 5000, ± 2000, ± 1000, ± 300, ± 100, ± 30, ± 10, ± 3 |
| Range of analog display | inch | ± .19", ± .07", ± .03", ± .01", ± .003", ± .001", ± .0004", ± .0001" |
| Resolution | µm | 0.01, 0.1, 1 |
| Resolution | inch | .000005" |
| Scale graduation value | µm | 500, 200, 100, 20, 10, 2, 1, 0.2 |
| Scale graduation value | inch | .019", .007", .002", .001", .0002", .0001", .00002", .00001" |
| Angle units | degrees, radians | |
| Measuring combination | +A, -A, +B, -B, A+B, +A-B, -A+B, -A-B | |
| Features | 3 | |
| Dynamic functions | Max, Min, TIR (Max-Min), (Max+Min)/2, Average | |
| Statistical functions | Length, Angle | |
| Configuration | Keyboard | |
| Data transmission rate | Hz | 30 |
| Refresh rate | fps | 30 |
| Error limit, digital display | 0.3% (min. 0.2 µm); 0.3% (min. 0.04 µm)* * (with N 1702 M-HR) | |
| Error limit, analog display | 0.25% of the end scale value / 0.3% of the displayed value | |
| Data interface | USB | |
| Control inputs | Control input programmable (functions and function sequences) | |
| Energy supply | Power source, 230 V/115 V; 50/60 Hz | |
| IP protection category | IP 42 | |

ACCESSORIES

| Order no. | Description | Type |
|-----------|--|---------------------|
| 5331120 | Module for inductive probes | N 1702 M |
| 5331125 | Module for inductive probes | N 1702 M-HR |
| 5331121 | Module for inductive probes | N 1702 T |
| 5331122 | Module for inductive probes | N 1702 U |
| 5331161 | Module for incremental sensors | N 1702 VPP |
| 5331155 | Module for pneumatic gages | N 1701 PF-2500/5000 |
| 5331157 | Module for pneumatic gages | N 1701 PF-10000 |
| 5312950 | Extension rail for Millimar C 1202 to fit two N 1701 PF/PM modules | |
| 4102603 | Data cable USB bidirectional (2 m) | DK-U1 |
| 4102606 | Interface adapter with data cable Digimatic (2 m) | DK-D1 |
| 4102058 | Foot switch to trigger data transmission | 16 Esf |
| 2258471 | Air filter/precision pressure regulator kit for measuring module N 1701 PF | |



Millimar S 1840 M / S 1840 F

Compact column amplifier



FEATURES

- Easy-to-read 3-color analog display
- Measurement in conjunction with inductive probes (e. g. Mahr P2004) or electronic plug gages, etc.
- 2 inputs for inductive probes (compatible with probes from Mahr, Federal)
- Extensive calculation of input signals; $\pm A$, $\pm B$ and all combinations
- Dynamic measurements; Max, Min, Max-Min, Average
- Programmable either via the integrated keypad or the RS-232 interface by means of MS - Windows® configuration software
- Programmable warning and tolerance limits (exceeding the limit causes the color to change from yellow to red)
- Backlit, two-line LCD for displaying measured values, help texts and units of measurement
- 1 analog output
- 3 digital inputs (e.g. measurement start, master measurement)
- 3 digital outputs for good – reject – rework, measuring time
- **Package contains:** instruction manual, power source
- **Software:** MarCom Professional free download: www.mahr.com/marcom (only for Mahr data cables and wireless systems with USB and RS-232 interface)



TECHNICAL DATA

| Order no. | 5318400 | | 5318402 | |
|----------------------------------|---|--|--|--|
| Type | S 1840 M | | S 1840 F | |
| Display | 101 LED elements, 3 colors | | | |
| Range of digital display | μm | $\pm 2000, \pm 10000$ | | |
| Range of analog display | μm | $\pm 10, \pm 30, \pm 100, \pm 300, \pm 1000, \pm 3000, \pm 10000$, tolerance related | | |
| Range of analog display | inch | $\pm .0003", \pm .001", \pm .003", \pm .01", \pm .03", \pm .1", \pm .3"$, tolerance related | | |
| Resolution | μm | 0.01, 0.1 | | |
| Resolution | inch | .000001", .000005" | | |
| Tolerance display | Via color changes in the analog display | | | |
| Measuring range, inductive probe | μm | $\pm 200, \pm 2000$ | | |
| Probe inputs | 2 | | | |
| Compatibility | Mahr | | Federal | |
| Measuring combination | +A, -A, +B, -B, A+B, +A-B, -A+B, -A-B | | | |
| Features | 2 | | | |
| Dynamic functions | Max, Min, Max-Min, (Max+Min)/2, Mean | | | |
| Configuration | PC, keyboard | | | |
| Data transmission rate | Hz | 40 | | |
| Error limit, digital display | 0.3% (min. 0.2 μm) | | | |
| Error limit, analog display | 1% (101 LEDs) | | | |
| Data interface | RS-232C, wireless | | | |
| Control inputs | 3 optocoupler inputs, 24 V, 10 mA | | | |
| Control outputs | 3 optocoupler outputs, 24 V, 100 mA | | | |
| Analog output | Max. ± 5 V, sensitivity adjustable | | Max. ± 5 V, sensitivity adjustable | |
| Energy supply | Power source, 230 V/115 V; 50/60 Hz | | | |
| IP protection category | IP 42 | | | |

| Order no. | Width | Height | Depth |
|-----------|-------|--------|-------|
| | mm | mm | mm |
| 5318400 | 47 | 487 | 144 |
| 5318402 | 47 | 487 | 144 |

ACCESSORIES

| Order no. | Description | Type |
|-----------|---|----------------|
| 5330901 | Base plate for up to 3 columns | |
| 5318430 | Control unit with 3 push buttons | |
| 5330955 | Foot switch for input 1 | |
| 5330956 | Foot switch for input 2 | |
| 5330957 | Foot switch for input 3 | |
| 7032401 | 25 pin connector, non-wired for I/O port | |
| 7024634 | Data connection cable RS232C (3 m) | |
| 4102331 | Millimar - USB adapter cable RS-232-USB (0.2 m) | Millimar - USB |
| 4102233 | RS-232 e transmitter for e-Stick | RS-232 e |
| 4102230 | e-Stick receiver | e-Stick |



Millimar S 1840 PE/F

Compact column measuring instrument



FEATURES

- Measuring results can be determined and addressed at a glance
- Suitable for measurements with pneumatic measuring equipment
- Offers a wide range of functions for the combined evaluation of signals from static and dynamic measurements
- Measuring results are displayed with 101 three color LEDs if programmable warning and tolerance limits are exceeded, LED segments on display change color accordingly from green to yellow or red
- When using pneumatic compact amplifiers, it is recommended at all times to use both a pressure regulator and a supply filter (see accessories)
- Clear, three color analog light bar display of warning and tolerance limits
- Backlit, two line LCD for displaying measured values, help texts and units of measurement
- 1 channel
- RS-232 interface
- Analog output
- 3 digital inputs for measurement start, master measurement, etc.
- 3 digital outputs for good, reject, rework classification, measuring time, etc.
- **Dynamic measurements:** Max, Min, Max-Min, Max+Min, Average
- Can either be programmed via the integrated membrane keypad using the menu driven interface or via the configuration software for MS Windows®
- 1-point or 2-point master measurement
- Password block in setup mode
- **Package contains:** instruction manual, power source
- **Software:** MarCom Professional free download: www.mahr.com/marcom (only for Mahr data cables and wireless systems with USB and RS-232 interface)



TECHNICAL DATA

| Order no. | 5318455 | 5318457 |
|--|---|---|
| Type | S 1840 PE/F | |
| Display | 101 LED elements, 3 color | |
| Range of analog display | µm | ± 3, ± 10, ± 30, ± 100, ± 300, ± 1000, ± 3000, ± 10000, tolerance related |
| Range of analog display | inch | ± .0001", ± .0003", ± .001", ± .003", ± .01", ± .03", ± .1", ± .3", tolerance related |
| Resolution | µm | 0.1 |
| Resolution | inch | .000005" |
| Tolerance display | Via color change of the analog display | |
| Inputs for pneumatic measuring equipment | 1 | |
| Compatibility | Federal | |
| Magnification | 2500:1 | 10000:1 |
| Measuring combination | +A, -A | |
| Features | 1 | |
| Dynamic functions | Max, Min, Max-Min, (Max+Min)/2, Average | |
| Configuration | PC, keyboard | |
| Zero setter | Electrical | |
| Error limit | 0.5 –1% | |
| Error limit, digital display | +/-1 place | |
| Error limit, analog display | 1% (101 LEDs) | |
| Air supply connection | Ø 8mm | |
| Air pressure | 2.1 bar ± 5% | |
| Air consumption m³/h | Approx. 1–2 m³ | |
| Data interface | RS-232C, wireless | |
| Control inputs | 3 optocoupler inputs, 24 V, 10 mA | |
| Control outputs | 3 optocoupler outputs, 24 V, 100 mA | |
| Analog output | 1 V/mm | |
| Energy supply | Power source, 230 V/115 V; 50/60 Hz | |
| IP protection category | IP 43 | |

| Order no. | Width | Height | Depth |
|-----------|-------|--------|-------|
| | mm | mm | mm |
| 5318455 | 47 | 487 | 144 |
| 5318456 | 47 | 487 | 144 |
| 5318457 | 47 | 487 | 144 |

ACCESSORIES

| Order no. | Description | Type |
|-----------|---|----------------|
| 5330914 | Base foot with 1 pressure regulator | |
| 5330915 | Base foot with 2 pressure regulators | |
| 5330916 | Base foot with 3 pressure regulators | |
| 2121236 | Supply filter with adapter kit | |
| 5318430 | Control unit with 3 push buttons | |
| 5330955 | Foot switch for input 1 | |
| 5330956 | Foot switch for input 2 | |
| 5330957 | Foot switch for input 3 | |
| 7024634 | Data connection cable RS232C (3 m) | |
| 4102331 | Millimar - USB adapter cable RS-232-USB (0.2 m) | Millimar - USB |
| 4102233 | RS-232 e transmitter for e-Stick | RS-232 e |
| 4102230 | e-Stick receiver | e-Stick |

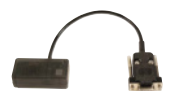

Millimar C 1750 PC

Measuring computer

FEATURES

- Robust 10.1" touch PC with i5 processor
- 8GB memory, industrial 256GB SSD
- IP65 front housing
- Interactive, touch-sensitive software
- Very simple and intuitive to use
- User-friendly creation of measuring tasks
- Access to predefined wizards for maximum ease of use
- Management of measuring tasks (save and load function)
- Measuring task linked to images or drawings
- Static and dynamic recording of measuring values
- Supported by graphical operating elements
- Live visualization of measuring values
- Simultaneous display of 128 digital or analog measurement values
- The Millimar N 1700 modules support a wide range of inductive measuring probes as well as Mahr instruments with a data interface
- Connection of Mahr measuring technologies via Integrated Wireless
- Data export to MS Excel or in qs-Stat format (dfq or dfx/dfd format)
- Password-protected user levels (3 levels)
- Online help (operating instructions) can be accessed directly from the software
- **Battery type:** CR 2032 (3V Lithium)
- **Package contains:** Millimar Cockpit software incl. 10.1" Touch-PC, preinstalled Windows 10 IoT "Value", Mahr license key, Recovery-Stick 16 GB, operating instructions (online help), power source, VESA 100 standard stand



Application:

- Convenient measuring computer with smart and universal software for complex measuring tasks in the manufacturing sector

TECHNICAL DATA

| Order no. | 5312870 | | |
|-------------------------|--|---|--|
| Type | C 1750 PC | | |
| Display | Vertical bar graph, horizontal bar graph, analog display or circular scale, digital display, any combination of display types can be chosen for each feature | | |
| Range of analog display | µm | ± 10000, ± 5000, ± 2000, ± 1000, ± 500, ± 200, ± 100, ± 50, ± 20, ± 10, tolerance related | |
| Range of analog display | inch | ± .5", ± .2", ± .1", ± .05", ± .02", ± .01", ± .005", ± .002", ± .001", ± .0005", tolerance related | |
| Resolution | µm | 0.01 | |
| Resolution | inch | .000001" | |
| Tolerance display | Upper and lower tolerance limit (per feature) Upper and lower warning limit (per feature) | | |
| Measuring range | mm | Dependent on measuring instrument | |
| Angle units | Degrees, radians | | |
| Compatibility | USB, Integrated Wireless, Millimar N 1700 | | |
| Measuring combination | Predefined formula templates for standard features Links entered via comprehensive formula editor | | |
| Features | 128 | | |
| Dynamic functions | Max, Min, Max-Min, Max+Min | | |
| Classification | Max. 20 classes | | |
| Control inputs | Via N 1704 I/O | | |
| Control outputs | Via N 1704 I/O | | |
| Energy supply | 100–240V ACDC active switching; 12V DC-Out | | |
| IP protection category | IP 65 (front panel) | | |

| Order no. | Width | Height | Depth |
|-----------|-----------|-----------|----------|
| 5312870 | mm 278 | mm 203 | mm 49 |

ACCESSORIES

| Order no. | Description | Type |
|-----------|---|---------------------|
| 5312802 | Software option: measure history | |
| 5331130 | USB connecting module | N 1701 USB |
| 5331120 | Module for inductive probes | N 1702 M |
| 5331125 | Module for inductive probes | N 1702 M-HR |
| 5331140 | Module for inductive probes | N 1704 M |
| 5331121 | Module for inductive probes | N 1702 T |
| 5331141 | Module for inductive probes | N 1704 T |
| 5331122 | Module for inductive probes | N 1702 U |
| 5331142 | Module for inductive probes | N 1704 U |
| 5331155 | Module for pneumatic gages | N 1701 PF–2500/5000 |
| 5331133 | Power supply module | N 1701 PS |
| 5331134 | I/O module | N 1704 I/O |
| 4102220 | Receiver for instruments with Integrated Wireless | i-Stick |
| 4102357 | 16 EXu data connection cable USB (2 m) | 16 EXu |
| 4346023 | 2000 USB data connection cable USB (2 m) | 2000 USB |
| 4102331 | Millimar - USB adapter cable RS–232-USB (0.2 m) | Millimar - USB |



Millimar Cockpit 13

Measuring software

FEATURES

- Interactive, touch-enabled software
- Easy and intuitive operation
- User-friendly creation of measurement tasks
- Easiest operation through access to predefined formula templates
- Management of measurement tasks (storage and loading function)
- Linking the measurement task with images or drawings
- Static and dynamic measurement value acquisition
- Supported by graphical control elements
- Live visualization of measured values
- Digit and scale displays of up to 128 features simultaneously
- Connection of Millimar N 1700 modules in conjunction with inductive probes as well as Mahr measuring instruments with data interface
- Connection of Mahr measuring instruments with Integrated Wireless
- Data paging in MS-Excel or as qs-Stat data format (dfq or dfx resp. dfd format)
- Password-protected operator levels (3 levels)
- Online help (operating instructions) directly accessible from the software
- **Package contains:** Mahr license key, installation disk, operating instructions (online help)



Application:

- Smart and universally applicable software for complex measurement tasks in the manufacturing sector

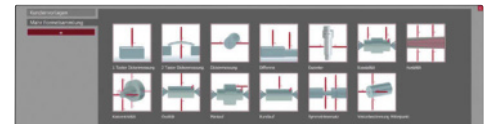

TECHNICAL DATA

| | | | |
|-------------------------|--|--|--|
| Order no. | 5312865 | | |
| Type | Cockpit 13 | | |
| Display | Vertical bar display Horizontal bar display Analog display or round scale | | |
| Range of analog display | μm | $\pm 10000, \pm 5000, \pm 2000, \pm 1000, \pm 500, \pm 200, \pm 100, \pm 50, \pm 20, \pm 10$, tolerance related | |
| Range of analog display | inch | $\pm .5", \pm .2", \pm .1", \pm .05", \pm .02", \pm .01", \pm .005", \pm .002", \pm .001", \pm .0005"$, tolerance related | |
| Resolution | μm | 0.01 | |
| Resolution | inch | .0000001" | |
| Tolerance display | Upper and lower tolerance limit (per characteristic) Upper and lower warning limit (per characteristic) | | |
| Measuring range | mm | Depending on the measuring device | |
| Compatibility | USB, Integrated Wireless, Millimar N 1700 | | |
| Measuring combination | Predefined formula templates for standard characteristics Input of links via extensive formula editor | | |
| Features | 128 | | |
| Classification | Max. 20 classes | | |
| Control inputs | Via N 1704 I/O module (5331134) | | |
| Control outputs | Via N 1704 I/O module (5331134) | | |

ACCESSORIES

| Order no. | Description | Type |
|-----------|---|---------------------|
| 5312802 | Software option: measure history | |
| 5331130 | USB connecting module | N 1701 USB |
| 5331120 | Module for inductive probes | N 1702 M |
| 5331125 | Module for inductive probes | N 1702 M-HR |
| 5331140 | Module for inductive probes | N 1704 M |
| 5331121 | Module for inductive probes | N 1702 T |
| 5331141 | Module for inductive probes | N 1704 T |
| 5331122 | Module for inductive probes | N 1702 U |
| 5331142 | Module for inductive probes | N 1704 U |
| 5331155 | Module for pneumatic gages | N 1701 PF-2500/5000 |
| 5331133 | Power supply module | N 1701 PS |
| 5331134 | I/O module | N 1704 I/O |
| 4102220 | Receiver for instruments with Integrated Wireless | i-Stick |
| 4102357 | 16 EXu data connection cable USB (2 m) | 16 EXu |
| 4346023 | 2000 USB data connection cable USB (2 m) | 2000 USB |
| 4102331 | Millimar - USB adapter cable RS-232-USB (0.2 m) | Millimar - USB |



Millimar N 1702 M / N 1702 T / N 1702 U / N 1702 M-HR / N 1704 M / N 1704 T / N 1704 U

Module for inductive probes

FEATURES

- Flexibly configurable RS-485 bus modules
- Powerful connection modules for evaluating measuring sensors (inductive/pneumatic)
- Synchronous data retrieval from multiple connected measuring probes
- Ability to connect the N 1700 modules to the smart and universally applicable Millimar Cockpit Software
- Connects all compatible probe types using one module
- Flexible and modular product combinations to tackle customer-specific measuring tasks
- Maximum theoretical bus data rate of 4189 values/s (depending on the number of connected channels)
- Package contains: instruction manual



Application:

- Smart and flexible combination of measuring modules and software for solving customer-specific measuring tasks.



TECHNICAL DATA

| Order no. | 5331120 | 5331121 | 5331122 | 5331125 | 5331140 | 5331141 | 5331142 | |
|----------------------------------|---|----------|----------|---|--|---------------------|----------|-----|
| Type | N 1702 M | N 1702 T | N 1702 U | N 1702 M-HR | N 1704 M | N 1704 T | N 1704 U | |
| Resolution | 0.1 | | 0.01 | | 0.1 | | | |
| Measuring range, inductive probe | ± 5000, ± 2000, ± 1000, ± 500 | | ± 200 | | ± 5000, ± 2000, ± 1000, ± 500 | | | |
| Probe inputs | 2 | | | 4 | | | | |
| Compatibility | Mahr, Mahr 1340, Mahr half-bridge, Mahr LVDT, Mahr VLDT | Tesa | Marposs | Mahr, Mahr 1340, Mahr half-bridge, Mahr LVDT, Mahr VLDT | Mahr, Mahr half-bridge, Mahr LVDT, Mahr VLDT | Tesa | Marposs | |
| Configuration | Millimar Cockpit Software | | | | | | | |
| Data transmission rate | Hz | | 4189 | | | | | |
| Error limit | 0.3 % (min. 0.2 µm) | | | 0.3 % (min. 0.04 µm) | | 0.3 % (min. 0.2 µm) | | |
| Data interface | RS-485 | | | | | | | |
| Current consumption | mA | | 115 | 95 | 115 | 180 | 150 | 180 |
| Energy supply | + 5V from N 1700 Bus | | | | | | | |
| IP protection category | IP 42 | | | | | | | |

| Order no. | Width | Height | Depth |
|-----------|-------|--------|-------|
| | mm | mm | mm |
| 5331120 | 77 | 54.8 | 66 |
| 5331121 | 77 | 54.8 | 66 |
| 5331122 | 77 | 54.8 | 66 |
| 5331125 | 77 | 54.8 | 66 |
| 5331140 | 116.5 | 54.8 | 66 |
| 5331141 | 116.5 | 54.8 | 66 |
| 5331142 | 116.5 | 54.8 | 66 |

Millimar N 1702 M / N 1702 T / N 1702 U / N 1702 M-HR / N 1704 M / N 1704 T / N 1704 U

Module for inductive probes

ACCESSORIES

| Order no. | Description | Type |
|-----------|------------------------------------|------------------------|
| 5313010 | Inductive probe, ± 1 mm | 1301 |
| 5313030 | Inductive probe, ± 1 mm | 1303 |
| 5313049 | Inductive probe, ± 1 mm | 1304 K |
| 5313180 | Inductive probe, $-0.3 \dots 1$ mm | 1318 |
| 5313400 | Inductive probe, ± 2 mm | 1340 |
| 4400180 | Inductive probe, ± 2 mm | P1300 MA |
| 4400182 | Inductive probe, ± 2 mm | P1300 MA without cable |
| 4400181 | Inductive probe, ± 2 mm | P1300 MB |
| 4400183 | Inductive probe, ± 2 mm | P1300 MB without cable |
| 5323040 | Inductive probe, ± 0.5 mm | P2001 M |
| 5323010 | Inductive probe, ± 2 mm | P2004 M |
| 5323020 | Inductive probe, ± 2 mm | P2004 MA |
| 5323030 | Inductive probe, ± 2 mm | P2004 MB |
| 5324010 | Inductive probe, ± 5 mm | P2010 M |
| 5324020 | Inductive probe, ± 5 mm | P2010 MA |
| 5324030 | Inductive probe, ± 5 mm | P2010 MB |
| 5324070 | Inductive probe, ± 2 mm | P2104 MA |
| 5324080 | Inductive probe, ± 2 mm | P2104 MB |
| 4400190 | Inductive probe, ± 2 mm | P1300 TA |
| 4400191 | Inductive probe, ± 2 mm | P1300 TB |
| 5323011 | Inductive probe, ± 2 mm | P2004 T |
| 5323021 | Inductive probe, ± 2 mm | P2004 TA |
| 5323031 | Inductive probe, ± 2 mm | P2004 TB |
| 5324021 | Inductive probe, ± 5 mm | P2010 TA |
| 5324031 | Inductive probe, ± 5 mm | P2010 TB |
| 5324071 | Inductive probe, ± 2 mm | P2104 TA |
| 5324081 | Inductive probe, ± 2 mm | P2104 TB |
| 5323013 | Inductive probe, ± 2 mm | P2004 U |
| 5323023 | Inductive probe, ± 2 mm | P2004 UA |
| 5323033 | Inductive probe, ± 2 mm | P2004 UB |
| 5324023 | Inductive probe, ± 5 mm | P2010 UA |
| 5324033 | Inductive probe, ± 5 mm | P2010 UB |
| 5324073 | Inductive probe, ± 2 mm | P2104 UA |
| 5324083 | Inductive probe, ± 2 mm | P2104 UB |
| 4400192 | Inductive probe, ± 2 mm | P1300 TA without cable |
| 4400193 | Inductive probe, ± 2 mm | P1300 TB without cable |



Millimar N 1702 VPP

Module for incremental sensors

FEATURES

- Flexibly combinable RS-485 bus modules
- Powerful connection modules for evaluating incremental measuring sensors or encoders
- Reference point evaluation
- Synchronous data retrieval from multiple connected measuring probes
- Can be used as a measuring module on the Millimar C 1202 as of firmware version 1.1.0.0
- Ability to connect the N 1700 modules to the smart and universally applicable Millimar Cockpit Software
- Connects all compatible measuring probe types using one module
- Flexible and modular product combinations to tackle customer-specific measuring tasks
- Maximum theoretical bus data rate of 4189 values/s (depending on the number of connected channels)
- **Package contains:** instruction manual



Application:

- Smart and flexible combination of measuring modules and software for solving customer-specific measuring tasks.

TECHNICAL DATA

| Order no. | 5331161 | |
|------------------------|----------------------|---|
| Type | N 1702 VPP | |
| Resolution | μm | 0.01, 0.1 |
| Measuring range | mm | 30 bit counter Dependent on the signal period of the sensor and set interpolation Adjustable interpolation factors 256, 128, 64 or 32 |
| Probe inputs | 2 | |
| Compatibility | Incremental 1 Vss | |
| Configuration | Millimar C 1202 | |
| Data transmission rate | Hz | 4189 |
| Data interface | RS-485 | |
| Current consumption | mA | 350 |
| Energy supply | + 5V from N 1700 Bus | |
| IP protection category | IP 42 | |

| Order no. | Width | Height | Depth |
|-----------|-------|--------|-------|
| | mm | mm | mm |
| 5331161 | 77 | 53 | 66 |

ACCESSORIES

| Order no. | Description | Type |
|-----------|--------------------------------------|----------|
| 5315081 | Incremental measuring probe P 1512 V | P 1512 V |
| 5315311 | Incremental measuring probe P 1530 V | P 1530 V |

Millimar N 1701 PM-2500 / N 1701 PM-5000 / N 1701 PM-10000 / N 1701 PF-2500/5000 / N 1701 PF-2500/5000-4 / N 1701 PF-10000

Module for pneumatic gages

FEATURES

- Flexibly configurable RS-485 bus modules
- Powerful connection modules for evaluating measuring sensors (inductive/pneumatic)
- Synchronous data retrieval from multiple connected measuring sensors
- Ability to connect the N 1700 modules to the smart and universally applicable Millimar Cockpit Software
- Flexible and modular product combinations to tackle customer-specific measuring tasks
- Maximum theoretical bus data rate of 4189 values/s (depending on the number of connected channels)
- **Package contains:** instruction manual



Application:

- Smart and flexible combination of measuring modules and software for solving customer-specific measuring tasks.

TECHNICAL DATA

| Order no. | 5331150 | 5331151 | 5331152 | 5331155 | 5331156 | 5331157 |
|--|---|-------------------------|---|---|---|-----------------------|
| Type | N 1701 PM-2500 | N 1701 PM-5000 | N 1701 PM-10000 | N 1701 PF-2500/5000 | N 1701 PF-2500/5000-4 | N 1701 PF-10000 |
| Resolution | 0.1 | | | | | |
| Resolution | .000005" | | | | | |
| Measuring span | 100 | 50 | 25 | | | |
| Measuring range | ± 50 µm (±0.00196 inch) | ± 25 µm (±0.00098 inch) | ± 12.5 µm (±0.00049 inch) | ± 40 µm (±0.0015 inch) / ± 20 µm (±0.00075 inch), tooling dependent | | ± 8 µm (±0.0003 inch) |
| Inputs for pneumatic measuring equipment | 1 | | | | | |
| Compatibility | Mahr | | | Mahr-Federal | | |
| Measuring principle | Differential pressure | | | | | |
| Magnification | 2500:1 | 5000:1 | 10000:1 | 2500:1, 5000:1 | | 10000:1 |
| Configuration | Millimar Cockpit Software | | | | | |
| Zero setter | Electrical | | | | | |
| Data transmission rate | 4189 Hz | | | | | |
| Error limit | ± 0.8 µm in the range ± 38 µm and ± 0.5 µm in the range ± 25 µm | | | | | |
| Number of jets | 2 | | 1-3 | | 4 | 1-3 |
| Air supply connection | | | | 3/8-32 Male | | 9/32-40 Male |
| Compressed air setting duration | ≤ 0.3 seconds (with 1 m / 3.3 ft hose) ≤ 0.5 seconds (with 2 m / 6.6 ft hose) | | ≤ 0.5 seconds (with 1 m / 3.3 ft hose) ≤ 0.7 seconds (with 2 m / 6.6 ft hose) | | ≤ 0.3 seconds (with 1 m / 3.3 ft hose) ≤ 0.5 seconds (with 2 m / 6.6 ft hose) | |
| Air pressure | 2.0 bar / 29 psi ± 5 % | | | 2.1 bar / 30.4 psi ± 5 % | | |
| Air consumption | 1-2 | | | | | |
| Data interface | RS-485 | | | | | |
| Current consumption | 32 mA | | | | | |
| Energy supply | + 5V from N 1700 Bus | | | | | |

| Order no. | Width | Height | Depth |
|-----------|-------|--------|-------|
| | mm | mm | mm |
| 5331150 | 90 | 50 | 66 |
| 5331151 | 90 | 50 | 66 |
| 5331152 | 90 | 50 | 66 |
| 5331155 | 90 | 50 | 66 |
| 5331156 | 90 | 50 | 66 |
| 5331157 | 90 | 50 | 66 |

ACCESSORIES

| Order no. | Description |
|-----------|--|
| 2258476 | Air filter/precision pressure regulator kit for measuring module N 1701 PM |
| 2258471 | Air filter/precision pressure regulator kit for measuring module N 1701 PF |

Millimar N 1704 I/O

I/O module

FEATURES

- Flexible combination of RS485 bus modules
- Capable modules for the evaluation of measuring sensors
- Synchronous data enquiry of multiple connected sensors
- Ability to connect the N 1700 modules to the smart and universally applicable Millimar Cockpit Software
- Connection of all types of measuring sensors within the same compatibility
- Modular and customizable selection of product combinations for solving each customer specific measuring tasks
- Theoretical bus data rate of max. 4189 values per second (depending on the number of connected channels)
- **Package contains:** plug connectors, instruction manual



Application:

- Smart and flexible combination of measuring modules and software for solving customer-specific measuring tasks.

TECHNICAL DATA

| | | | |
|---------------------|---|----|--|
| Order no. | 5331134 | | |
| Type | N 1704 I/O | | |
| Configuration | Millimar Cockpit Software | | |
| Data interface | RS-485 | | |
| Current consumption | mA | 70 | |
| Control inputs | 4 inputs, 10 –30 V | | |
| Control outputs | 4 outputs, 10 –30 V ESD protected, short-circuit proof | | |

| Order no. | Width | Height | Depth |
|-----------|-------|--------|-------|
| | mm | mm | mm |
| 5331134 | 77 | 54 | 66 |

ACCESSORIES

| Order no. | Description | Type |
|-----------|-----------------------------|--------------|
| 5331139 | Extension cable, length 1 m | N 1700 RS485 |

Millimar N 1701 USB

USB connecting module

FEATURES

- Flexible combination of RS-485-bus-modules
- Capable modules for the evaluation of measuring sensors
- Synchronous data enquiry of multiple connected sensors
- Ability to connect the N 1700 modules to the smart and universally applicable Millimar Cockpit Software
- Connection of all types of measuring sensors within the same compatibility
- Modular and customizable selection of product combinations for solving each customer specific measuring tasks
- Theoretical bus data rate of max. 4189 values per second (depending on the number of connected channels)
- **Package contains:** end module, instruction manual, USB cable

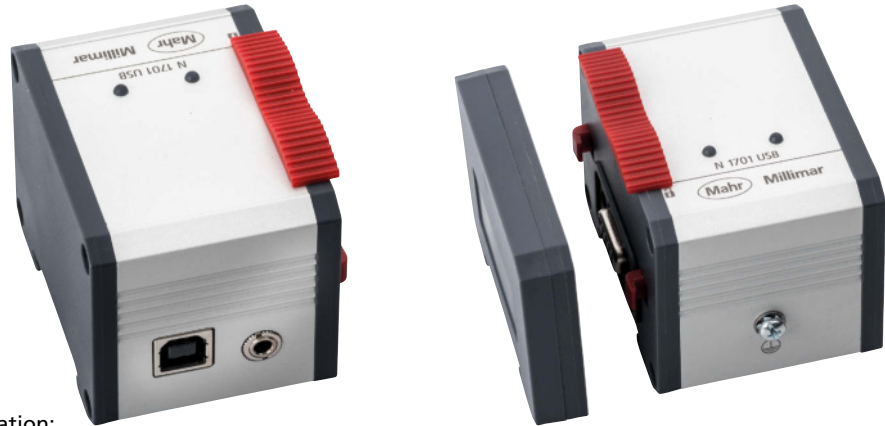

Application:

- Smart and flexible combination of measuring modules and software for solving customer-specific measuring tasks.

TECHNICAL DATA

| Order no. | 5331130 | | |
|----------------|---------------------------|-----|--|
| Type | N 1701 USB | | |
| Configuration | Millimar Cockpit Software | | |
| Data interface | USB, RS-485 | | |
| Current supply | mA | 430 | |

| Order no. | Width | Height | Depth |
|-----------|-------|--------|-------|
| | mm | mm | mm |
| 5331130 | 54 | 54 | 66 |

ACCESSORIES

| Order no. | Description | Type |
|-----------|--|--------------|
| 4102058 | Foot switch to trigger data transmission | 16 ESf |
| 5331139 | Extension cable, length 1 m | N 1700 RS485 |

Millimar N 1701 PS

Power supply module

FEATURES

- Flexible combination of RS485 bus modules
- Capable modules for the evaluation of measuring sensors
- Synchronous data enquiry of multiple connected sensors
- Ability to connect the N 1700 modules to the smart and universally applicable Millimar Cockpit Software
- Connection of all types of measuring sensors within the same compatibility
- Modular and customizable selection of product combinations for solving each customer specific measuring tasks
- Theoretical bus data rate of max. 4189 values per second (depending on the number of connected channels)
- **Package contains:** power source, instruction manual



Application:

- Smart and flexible combination of measuring modules and software for solving customer-specific measuring tasks.

TECHNICAL DATA

| Order no. | 5331133 | | |
|----------------|---------------------------|------|--|
| Type | N 1701 PS | | |
| Configuration | Millimar Cockpit Software | | |
| Data interface | RS-485 | | |
| Current supply | mA | 2000 | |
| Energy supply | 230 V/115 V; 50/60 Hz | | |

| Order no. | Width | Height | Depth |
|-----------|-------|--------|-------|
| | mm | mm | mm |
| 5331133 | 57 | 55 | 66 |

ACCESSORIES

| Order no. | Description | Type |
|-----------|-----------------------------|--------------|
| 5331139 | Extension cable, length 1 m | N 1700 RS485 |

Millimar μ Dimensionair® II

Mobile pneumatic length measuring instrument



FEATURES

- Value for money
- Versatile
- Innovative
- Robust
- Can be used as a handheld device, a stationary table-top device or even directly on the machine tool
- 54 protection rating - suitable for use in harsh workshop environments
- The compressed air flowing out of the measuring equipment removes any contaminations from the testpiece to ensure reliable measuring results
- Directly and clearly readable measuring results
- With its fixed ratio and controlled compressed air supply, this sturdy, reliable measuring instrument is ideal for use manufacturing environments

The μ Dimensionair II offers:

- Choice of setup with one standard or with Min/Max standards
- All other functions of the μ Max μ II digital dial comparator:
 - Dynamic measurement: Min, Max, measuring span
 - Multiplication factor and hold function ("freeze")
 - Choice of data transfer with serial number
- MarConnect data output: USB, Opto RS-232C, and Digimatic
- Versatility
- Interchangeable handle can be mounted on the base of the instrument (pistol grip) or as a regular bar handle flush with the measuring attachment, allowing the measuring equipment to be used on the workpiece in any situation
- If large, heavy measuring attachments are used, the handle can be mounted between the measuring attachment and the display (dumbbell grip), to provide a balanced, ergonomic measuring system
- Can be operated in a static position on a workbench using the optional measuring stand
- **Package contains:** instruction manual, supply hose AHO-2
- **Software:** MarCom Professional free download: www.mahr.com/marcom (only for Mahr data cables and wireless systems with USB and RS-232 interface)

Application:

- Applications with pneumatic measuring equipment requiring mobile measurement and evaluation.



TECHNICAL DATA

| Order no. | 2103200 | |
|--|--|--|
| Type | μ Dimensionair II | |
| Display | Analog display with one line digital display | |
| Digital display | Rotates through 270° | |
| Scale graduation value | μ m | 0.5, 1, 2 |
| Scale graduation value | inch | .00002", .00005", .0001" |
| Tolerance display | Two - over / under (3 class) | |
| Measuring range | mm | ± 0.020 mm, ± 0.040 mm, ± 0.080 mm |
| Inputs for pneumatic measuring equipment | 1 | |
| Compatibility | Federal | |
| Magnification | 5000:1, 2500:1, 1260:1 | |
| Features | 1 | |
| Dynamic functions | MAX, MIN, MAX-MIN | |
| Statistical functions | Difference, Nominal Average | |
| Error limit | $\pm 1\%$ of the total range | |
| Compressed air setting duration | Approximately 1 s | |
| Air pressure | 2.10 \pm .01 bar | |
| Repeatability [μ m] | ± 1 numerical increment | |
| Data interface | Digimatic, Opto RS-232C, USB, wireless | |
| Energy supply | Battery operation, approximately 3000 h | |
| IP protection category | IP 54 | |

| Order no. | Width | Height | Length | Depth |
|-----------|-------|--------|--------|-------|
| | mm | mm | mm | mm |
| 2103200 | 70 | 3 | 100 | 60 |

ACCESSORIES

| Order no. | Description | Type |
|-----------|---|----------|
| 2238020 | Pressure regulator with filter | |
| 2095924 | Pressure meter | |
| 2239307 | Universal bench mount | |
| 2237666 | Standard plastic handle | |
| 2240993 | Shut off slide valve | |
| 2241109 | Table stand for μ Dimensionair | |
| 2240594 | Swivel coupling adapter for rotating tooling | |
| 2201994 | Oil and water separator trap | AFL-24 |
| 2237713 | Connecting hose, 6 m | |
| 2202076 | Supply hose, 1.5 m | AHO-2 |
| 4102520 | Battery 3 V, CR 2032 | |
| 4346023 | 2000 USB data connection cable USB (2 m) | 2000 USB |
| 4346021 | Interface adapter with data cable Digimatic (2 m) | 2000 d |
| 4346020 | Data connection cable RS232C (2 m) | 2000 r |



Millimar | Electrical length measuring instruments inductive probe program

Millimar – P2000 Series

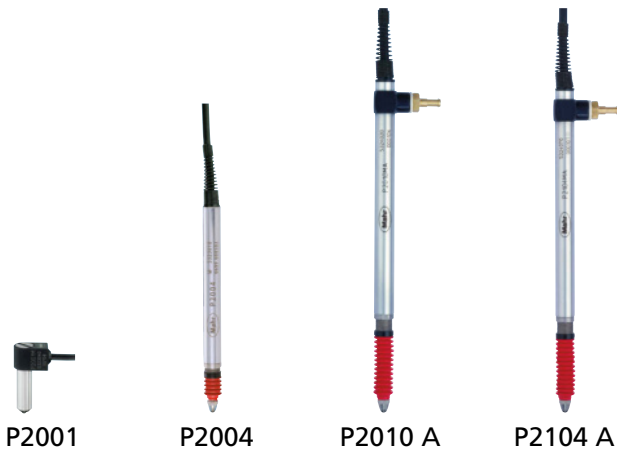

- Available in all prominent compatibilities (available in various type compatibilities)
- Wide product spectrum measuring ranges from 1 to 10 mm plus models with a compressed air (pneumatic) lifter or vacuum retraction
- With rotary stroke bearings (except P2001)
- High linearity over the total measuring range
- Excellent electromagnetic shielding (EMC)
- All probes (except P2001) can be easily converted from axial to radial by mounting a slip-on cap (included)

Millimar – P1300 Series (Mahr half-bridge)

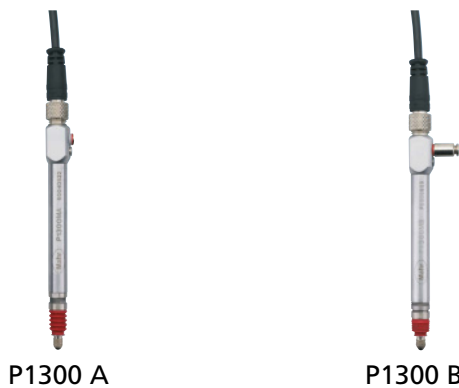

- Available in Mahr and Tesa compatibilities
- Well-proven and established Mahr half-bridge technology
- Easy to service: cable and probe can be separated via the plug-in connector
- Simple to change to pneumatic lifting
- Measuring spindle runs in rotary stroke bearings

Millimar – 1301 / 1303 / 1304 K / 1318 (Mahr-LVDT)



- Extremely robust in all operating conditions; measuring system is offset to guide and mounting shank
- Excellent clamping characteristics
- Measuring spindle runs in rotary stroke bearings (except 1318)
- Measuring spindle can be lifted with a cable release (1301/1303)

Millimar – 1340 Mahr high precision probe



- Can be used with Millimar C 1202 + N 1702 M-HR compact length gage
- Probe protected against dirt and moisture, therefore use in production-related areas possible
- Unprecedented measuring accuracy and minimum linearity error < 0.01 %, i.e. 0.4 µm over the total measuring range

General technical data of inductive probes

The measuring principle of inductive probes is based on the change of position of the magnet's conductive core moving within a coil system. Generally, this is distinguished between a half-bridge and LVDT's.

The Mahr P2000 series of probes applies a high linear, patented VLDT transducer which is similar to an LVDT transducer. This also operates according to a differential transformer principle.

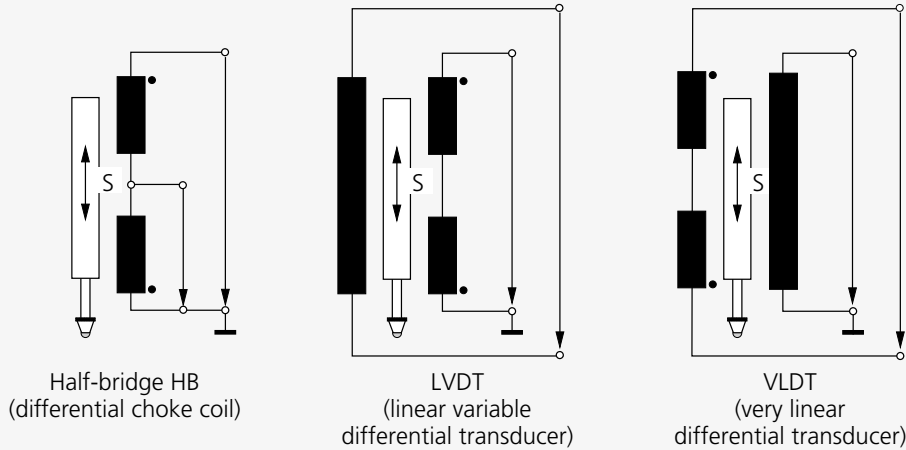

Electrical specification of various compatibilities

| | Type | Mahr | Tesa | Marposs | Mahr-Federal |
|-------------------|--------------------------------|-----------|-------|---------|--------------|
| Carrier frequency | KHz | 19.4 | 13 | 7.5 | 5 |
| Sensitivity | P2001 P2004 P2104 | 192 | 73.75 | 115 | 78.74 |
| | P1300 | 192 | 73.75 | — | — |
| | 1301 1303 1304 K 1318 | 192 | — | — | — |
| | P2010 | 19.2 | 29.5 | 11.5 | 7.874 |
| | Amplitude | V_{eff} | 5 | 3 | 3.5 |

Schematic drawings of Mahr input amplifiers according to the various compatibilities

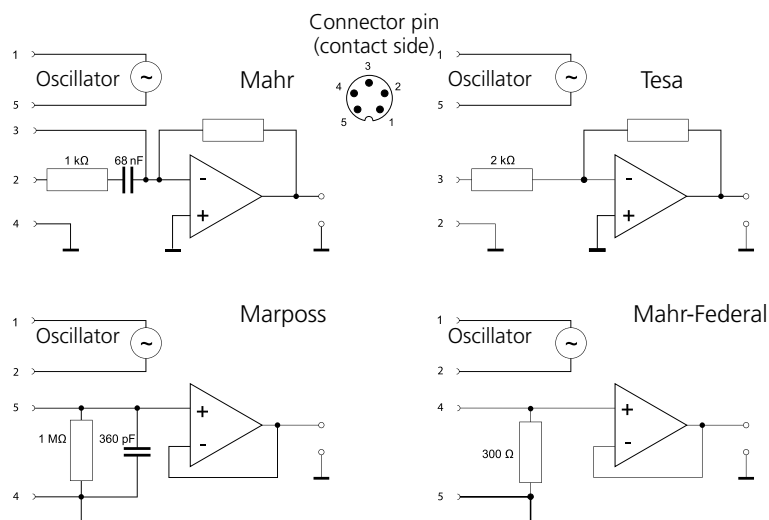

FEATURES

- Compact design
- Plain bearing guide
- High linearity over the entire measuring range
- Excellent electromagnetic shielding (EMC)
- Chemical resistance data:
 - Resistant to oil, gasoline, water and aliphatic compounds
 - Moderately resistant to acids, bases, solvents and ozone

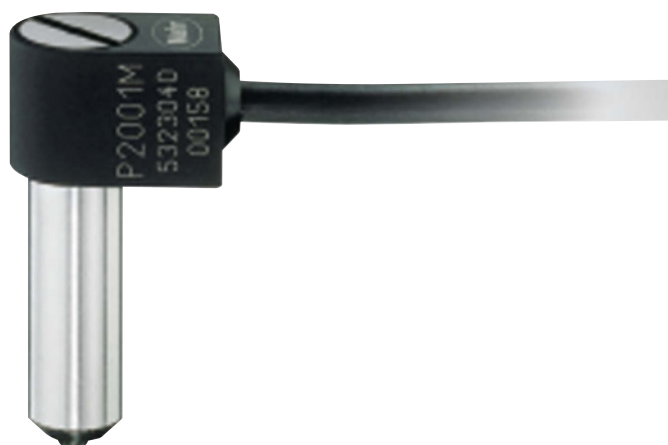

TECHNICAL DATA

| Order no. | | 5323040 |
|---------------------------------------|------------------------------|------------------|
| Type | | P2001 M |
| Measuring range | mm | ± 0.5 |
| Measuring range | inch | ± .020" |
| Measuring force | N | 0.75 N +/-0.15 N |
| Increase in measuring force | N/mm | 0.1 N/mm |
| Sensitivity deviation | % | 0.3 |
| Repeatability f_w | μm | 0.15 |
| Measuring value hysteresis f_u | μm | 0.2 |
| Linearity deviation within +/-0.1 mm | μm | 0.6 |
| Linearity deviation within +/-0.0039" | inch | 24 μm |
| Linearity deviation within +/-0.5 mm | μm | 1.5 |
| Linearity deviation within +/-0.020" | inch | 60 μm |
| IP protection category | | IP 40 |
| Cable length | m | 2.5 |
| Temperature coefficient | $\mu\text{m}/^\circ\text{C}$ | 0.15 |
| Compatibility | | Mahr VLDT |

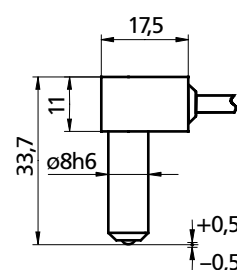

ACCESSORIES

| Order no. | Description | Type |
|-----------|-----------------------------------|---------|
| 5323130 | Extension cable 2.5 m (Mahr VLDT) | C2025 M |
| 5323140 | Extension cable 5 m (Mahr VLDT) | C2050 M |
| 5323150 | Extension cable 7.5 m (Mahr VLDT) | C2075 M |
| 5323160 | Extension cable 10 m (Mahr VLDT) | C2100 M |

Inductive probe

FEATURES

- Models with or without pneumatic lifter or load
- Measuring pin mounted in rotary stroke bearing
- High linearity over the entire measuring range
- Excellent electromagnetic shielding (EMC)
- All probes can be easily converted from axial to radial by mounting a slip on cap (included)
- Chemical resistance data:
 - Resistant to oil, gasoline, water and aliphatic compounds
 - Moderately resistant to acids, bases, solvents and ozone
- **Package contains:** instruction manual, cap for radial cable output, spanner for preliminary stroke setting



TECHNICAL DATA

| | Order no. | 5323010 | 5323011 | 5323013 |
|--------------------------------------|------------------------------|-----------|-------------------|---------|
| Type | | P2004 M | P2004 T | P2004 U |
| Measuring range | mm | | ± 2 | |
| Measuring range | inch | | ± .079" | |
| Distance to upper stop | mm...mm | | +2.2 ... 4.4 | |
| Distance to lower stop | mm...mm | | -2.2 ... 0 | |
| Distance to upper stop | inch...inch | | + .09173" | |
| Distance to lower stop | inch...inch | | -.09 ... 0" | |
| Lifter / retraction | | | Standard model | |
| Measuring force | N | | 0.75 N +/-0.15 N | |
| Increase in measuring force | N/mm | | 0.2 N/mm | |
| Sensitivity deviation | % | | 0.3 | |
| Repeatability f_w | μm | | 0.1 | |
| Measuring value hysteresis f_u | μm | | 0.5 | |
| Linearity deviation within +/-0.5 mm | μm | | 0.4 | |
| Linearity deviation within +/- .020" | inch | | 16 μm | |
| Linearity deviation within +/-1.0 mm | μm | | 1.5 | |
| Linearity deviation within +/- .039" | inch | | 60 μm | |
| Linearity deviation within +/-2.0 mm | μm | | 3 | |
| Linearity deviation within +/- .079" | inch | | 120 μm | |
| IP protection category | | | IP 64 | |
| Cable length | m | | 2.5 | |
| Temperature coefficient | $\mu\text{m}/^\circ\text{C}$ | | 0.15 | |
| Compatibility | | Mahr VLDT | Tesa | Marposs |

| Order no. | a | b | c | d | e | f | f | h | Connection thread |
|-----------|------|----|------|----|-----|-------|----|----|-------------------|
| 5323010 | mm | mm | mm | mm | mm | inch | mm | mm | M 2.5 |
| 5323011 | 88.7 | 28 | 21.3 | 6 | 9.2 | 0.315 | 8 | 14 | M 2.5 |
| 5323013 | 88.7 | 28 | 21.3 | 6 | 9.2 | 0.315 | 8 | 14 | M 2.5 |

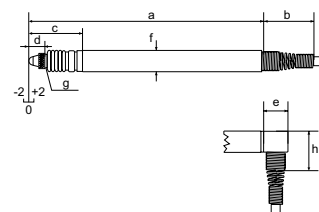

Inductive probe

FEATURES

- Models with or without pneumatic lifter or load
- Measuring pin mounted in rotary stroke bearing
- High linearity over the entire measuring range
- Excellent electromagnetic shielding (EMC)
- All probes can be easily converted from axial to radial by mounting a slip on cap (included)
- Chemical resistance data:
 - Resistant to oil, gasoline, water and aliphatic compounds
 - Moderately resistant to acids, bases, solvents and ozone
- **Package contains:** instruction manual, cap for radial cable output, spanner for preliminary stroke setting



TECHNICAL DATA

| | Order no. | 5323020 | 5323021 | 5323023 |
|--------------------------------------|------------------------------|-----------|-------------------|----------|
| Type | | P2004 MA | P2004 TA | P2004 UA |
| Measuring range | mm | | ± 2 | |
| Measuring range | inch | | ± .079" | |
| Distance to upper stop | mm...mm | | +2.2 ... 4.4 | |
| Distance to lower stop | mm...mm | | -2.2 ... 0 | |
| Distance to upper stop | inch...inch | | + .09173" | |
| Distance to lower stop | inch...inch | | -.09 ... 0" | |
| Lifter / retraction | | | Vacuum lifter | |
| Measuring force | N | | 0.75 N +/-0.15 N | |
| Increase in measuring force | N/mm | | 0.2 N/mm | |
| Sensitivity deviation | % | | 0.3 | |
| Repeatability f_w | μm | | 0.1 | |
| Measuring value hysteresis f_u | μm | | 0.5 | |
| Linearity deviation within +/-0.5 mm | μm | | 0.4 | |
| Linearity deviation within +/- .020" | inch | | 16 μm | |
| Linearity deviation within +/-1.0 mm | μm | | 1.5 | |
| Linearity deviation within +/- .039" | inch | | 60 μm | |
| Linearity deviation within +/-2.0 mm | μm | | 3 | |
| Linearity deviation within +/- .079" | inch | | 120 μm | |
| IP protection category | | | IP 64 | |
| Cable length | m | | 2.5 | |
| Temperature coefficient | $\mu\text{m}/^\circ\text{C}$ | | 0.15 | |
| Compatibility | | Mahr VLDT | Tesa | Marposs |

| Order no. | a | b | c | d | e | f | h | i | j | k | l | m | Connection thread |
|-----------|------|----|------|----|-----|----|----|------|-----|----|-----|------|-------------------|
| 5323020 | mm | mm | mm | mm | mm | mm | mm | mm | mm | mm | mm | mm | M 2.5 |
| 5323021 | 88.7 | 28 | 21.3 | 6 | 9.2 | 8 | 14 | 26.5 | 3.6 | 9 | 8.3 | 12.5 | M 2.5 |
| 5323023 | 88.7 | 28 | 21.3 | 6 | 9.2 | 8 | 14 | 26.5 | 3.6 | 9 | 8.3 | 12.5 | M 2.5 |

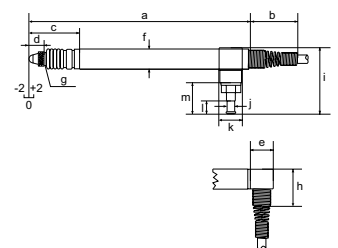

Inductive probe

FEATURES

- Models with or without pneumatic lifter or load
- Measuring pin mounted in rotary stroke bearing
- High linearity over the entire measuring range
- Excellent electromagnetic shielding (EMC)
- All probes can be easily converted from axial to radial by mounting a slip on cap, (included)
- Chemical resistance data:
 - Resistant to oil, gasoline, water and aliphatic compounds
 - Moderately resistant to acids, bases, solvents and ozone
- **Package contains:** instruction manual, cap for radial cable output, spanner for preliminary stroke setting



TECHNICAL DATA

| Order no. | 5323030 | 5323031 | 5323033 |
|--------------------------------------|-------------|--|-----------------|
| Type | P2004 MB | P2004 TB | P2004 UB |
| Measuring range | mm | ± 2 | |
| Measuring range | inch | ± .079" | |
| Distance to upper stop | mm...mm | +2.2 ... 4.4 | |
| Distance to lower stop | mm...mm | -2.2 ... 0 | |
| Distance to upper stop | inch...inch | +.09173" | |
| Distance to lower stop | inch...inch | -.09 ... 0" | |
| Lifter / retraction | | Compressed air retraction (max. 1 bar) | |
| Measuring force | N | Depending upon air pressure | |
| Sensitivity deviation | % | 0.3 | |
| Repeatability f_w | µm | 0.1 | |
| Measuring value hysteresis f_u | µm | 0.5 | |
| Linearity deviation within +/-0.5 mm | µm | 0.4 | |
| Linearity deviation within +/- .020" | inch | 16 µ" | |
| Linearity deviation within +/-1.0 mm | µm | 1.5 | |
| Linearity deviation within +/- .039" | inch | 60 µ" | |
| Linearity deviation within +/-2.0 mm | µm | 3 | |
| Linearity deviation within +/- .079" | inch | 120 µ" | |
| IP protection category | | IP 64 | |
| Cable length | m | 2.5 | |
| Temperature coefficient | µm/°C | 0.15 | |
| Compatibility | | Mahr VLDT | Tesa Marposs |

| Order no. | a | b | c | d | e | f | h | i | j | k | l | m | Connection thread |
|-----------|------|----|------|----|-----|----|----|------|-----|----|-----|------|-------------------|
| 5323030 | mm | mm | mm | mm | mm | mm | mm | mm | mm | mm | mm | mm | M 2.5 |
| 5323031 | 88.7 | 28 | 21.3 | 6 | 9.2 | 8 | 14 | 26.5 | 3.6 | 9 | 8.3 | 12.5 | M 2.5 |
| 5323033 | 88.7 | 28 | 21.3 | 6 | 9.2 | 8 | 14 | 26.5 | 3.6 | 9 | 8.3 | 12.5 | M 2.5 |

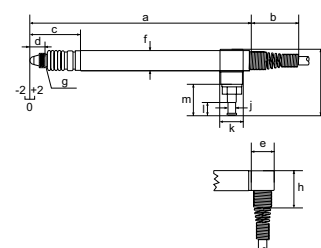

FEATURES

- Models with or without pneumatic lifter or load
- Measuring pin mounted in rotary stroke bearing
- High linearity over the entire measuring range
- Excellent electromagnetic shielding (EMC)
- All probes can be easily converted from axial to radial by mounting a slip on cap (included)
- Chemical resistance data:
 - Resistant to oil, gasoline, water and aliphatic compounds
 - Moderately resistant to acids, bases, solvents and ozone
- **Package contains:** instruction manual, cap for radial cable output, spanner for preliminary stroke setting



TECHNICAL DATA

| Order no. | | 5324010 |
|--------------------------------------|------------------------------|-------------------|
| Type | | P2010 M |
| Measuring range | mm | ± 5 |
| Measuring range | inch | ± .197" |
| Distance to upper stop | mm...mm | +5.3 |
| Distance to lower stop | mm...mm | -5.3 |
| Distance to upper stop | inch...inch | + .20" |
| Distance to lower stop | inch...inch | -.20" |
| Lifter / retraction | | Standard model |
| Measuring force | N | 0.75 N +/-0.15N |
| Increase in measuring force | N/mm | 0.1 N/mm |
| Sensitivity deviation | % | 0.3 |
| Repeatability f_w | μm | 0.2 |
| Measuring value hysteresis f_u | μm | 1 |
| Linearity deviation within +/-2.0 mm | μm | 4 |
| Linearity deviation within +/- .079" | inch | 160 μm |
| Linearity deviation within +/-5,0 mm | μm | 20 |
| Linearity deviation within +/- .197" | inch | 780 μm |
| IP protection category | | IP 64 |
| Cable length | m | 2.5 |
| Temperature coefficient | $\mu\text{m}/^\circ\text{C}$ | 0.15 |
| Compatibility | | Mahr |

| Order no. | a | b | c | d | e | f | h | Connection thread |
|-----------|-------|----|----|----|-----|----|----|-------------------|
| | mm | mm | mm | mm | mm | mm | mm | |
| 5324010 | 125.7 | 28 | 34 | 6 | 9.2 | 8 | 14 | |

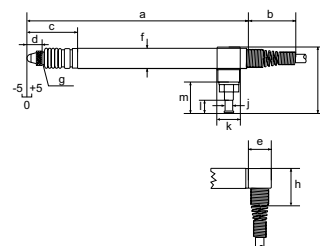

Inductive probe

FEATURES

- Models with or without pneumatic lifter or load
- Measuring pin mounted in rotary stroke bearing
- High linearity over the entire measuring range
- Excellent electromagnetic shielding (EMC)
- All probes can be easily converted from axial to radial by mounting a slip on cap (included)
- Chemical resistance data:
 - Resistant to oil, gasoline, water and aliphatic compounds
 - Moderately resistant to acids, bases, solvents and ozone
- **Package contains:** instruction manual, cap for radial cable output, spanner for preliminary stroke setting



TECHNICAL DATA

| Order no. | | 5324020 | 5324021 | 5324023 |
|---------------------------------------|------------------------------|-----------|-------------------|----------|
| Type | | P2010 MA | P2010 TA | P2010 UA |
| Measuring range | mm | | ± 5 | |
| Measuring range | inch | | ± .197" | |
| Distance to upper stop | mm...mm | | +5.3 | |
| Distance to lower stop | mm...mm | | -5.3 | |
| Distance to upper stop | inch...inch | | + .20" | |
| Distance to lower stop | inch...inch | | - .20" | |
| Lifter / retraction | | | Vacuum lifter | |
| Measuring force | N | | 0.75 N +/- 0.15 N | |
| Increase in measuring force | N/mm | | 0.1 N/mm | |
| Sensitivity deviation | % | | 0.3 | |
| Repeatability f_w | μm | | 0.2 | |
| Measuring value hysteresis f_u | μm | | 1 | |
| Linearity deviation within +/- 2.0 mm | μm | | 4 | |
| Linearity deviation within +/- .079" | inch | | 160 μm | |
| Linearity deviation within +/- 5.0 mm | μm | | 20 | |
| Linearity deviation within +/- .197" | inch | | 780 μm | |
| IP protection category | | | IP 64 | |
| Cable length | m | | 2.5 | |
| Temperature coefficient | $\mu\text{m}/^\circ\text{C}$ | | 0.15 | |
| Compatibility | | Mahr VLDT | Tesa | Marposs |

| Order no. | a | b | c | d | e | f | h | i | j | k | l | m | Connection thread |
|-----------|-------|----|----|----|-----|----|----|------|-----|----|-----|------|-------------------|
| | mm | mm | mm | mm | mm | mm | mm | mm | mm | mm | mm | mm | |
| 5324020 | 125.7 | 28 | 34 | 6 | 9.2 | 8 | 14 | 26.5 | 3.6 | 9 | 8.3 | 12.5 | M 2.5 |
| 5324021 | 125.7 | 28 | 34 | 6 | 9.2 | 8 | 14 | 26.5 | 3.6 | 9 | 8.3 | 12.5 | M 2.5 |
| 5324023 | 125.7 | 28 | 34 | 6 | 9.2 | 8 | 14 | 26.5 | 3.6 | 9 | 8.3 | 12.5 | M 2.5 |

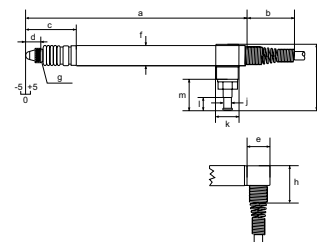

Inductive probe

FEATURES

- Models with or without pneumatic lifter or load
- Measuring pin mounted in rotary stroke bearing
- High linearity over the entire measuring range
- Excellent electromagnetic shielding (EMC)
- All probes can be easily converted from axial to radial by mounting a slip on cap (included)
- Chemical resistance data:
 - Resistant to oil, gasoline, water and aliphatic compounds
 - Moderately resistant to acids, bases, solvents and ozone
- **Package contains:** instruction manual, cap for radial cable output, spanner for preliminary stroke setting



TECHNICAL DATA

| Order no. | | 5324030 | 5324031 | 5324033 |
|---|------------------------------|--|----------|----------|
| Type | | P2010 MB | P2010 TB | P2010 UB |
| Measuring range | mm | | ± 5 | |
| Measuring range | inch | | ± .197" | |
| Distance to upper stop | mm...mm | | +5.3 | |
| Distance to lower stop | mm...mm | | -5.3 | |
| Distance to upper stop | inch...inch | | + .20" | |
| Distance to lower stop | inch...inch | | -.20" | |
| Lifter / retraction | | Compressed air retraction (max. 1 bar) | | |
| Measuring force | N | Depending upon air pressure | | |
| Sensitivity deviation | % | 0.3 | | |
| Repeatability f_w | μm | 0.2 | | |
| Measuring value hysteresis f_u | μm | 1 | | |
| Linearity deviation within ± 2.0 mm | μm | 4 | | |
| Linearity deviation within $\pm .079$ " | inch | 160 μ " | | |
| Linearity deviation within ± 5.0 mm | μm | 20 | | |
| Linearity deviation within $\pm .197$ " | inch | 780 μ " | | |
| IP protection category | | IP 64 | | |
| Cable length | m | 2.5 | | |
| Temperature coefficient | $\mu\text{m}/^\circ\text{C}$ | 0.15 | | |
| Compatibility | | Mahr VLDT | Tesa | Marposs |

| Order no. | a | b | c | d | e | f | h | i | j | k | l | m | Connection thread |
|-----------|-------|----|----|----|-----|----|----|------|-----|----|-----|------|-------------------|
| | mm | mm | mm | mm | mm | mm | mm | mm | mm | mm | mm | mm | |
| 5324030 | 125.7 | 28 | 34 | 6 | 9.2 | 8 | 14 | 26.5 | 3.6 | 9 | 8.3 | 12.5 | M 2.5 |
| 5324031 | 125.7 | 28 | 34 | 6 | 9.2 | 8 | 14 | 26.5 | 3.6 | 9 | 8.3 | 12.5 | M 2.5 |
| 5324033 | 125.7 | 28 | 34 | 6 | 9.2 | 8 | 14 | 26.5 | 3.6 | 9 | 8.3 | 12.5 | M 2.5 |

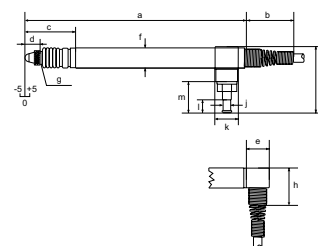

Inductive probe

FEATURES

- Models with pneumatic lifter or vacuum retraction
- Measuring pin mounted in rotary stroke bearing
- High linearity over the entire measuring range
- Excellent electromagnetic shielding (EMC)
- All probes can be easily converted from axial to radial by mounting a slip on cap (included)
- Chemical resistance data:
 - Resistant to oil, gasoline, water and aliphatic compounds
 - Moderately resistant to acids, bases, solvents and ozone
- **Package contains:** instruction manual, cap for radial cable output, spanner for preliminary stroke setting



TECHNICAL DATA

| | Order no. | 5324070 | 5324071 | 5324073 |
|--------------------------------------|-------------|-----------|------------------|----------|
| Type | | P2104 MA | P2104 TA | P2104 UA |
| Measuring range | mm | | ± 2 | |
| Measuring range | inch | | ± .079" | |
| Distance to upper stop | mm...mm | | +8.4 ... 10.4 | |
| Distance to lower stop | mm...mm | | -2.2 ... 0 | |
| Distance to upper stop | inch...inch | | .3341" | |
| Distance to lower stop | inch...inch | | -.09 ... 0" | |
| Lifter / retraction | | | Vacuum lifter | |
| Measuring force | N | | 0.75 N +/-0.15 N | |
| Increase in measuring force | N/mm | | 0.1 N/mm | |
| Sensitivity deviation | % | | 0.3 | |
| Repeatability f_w | µm | | 0.2 | |
| Measuring value hysteresis f_u | µm | | 1 | |
| Linearity deviation within +/-0.5 mm | µm | | 0.5 | |
| Linearity deviation within +/- .020" | inch | | 20 µ" | |
| Linearity deviation within +/-1.0 mm | µm | | 2 | |
| Linearity deviation within +/- .039" | inch | | 80 µ" | |
| Linearity deviation within +/-2.0 mm | µm | | 4 | |
| Linearity deviation within +/- .079" | inch | | 160 µ" | |
| IP protection category | | | IP 64 | |
| Cable length | m | | 2.5 | |
| Temperature coefficient | µm/°C | | 0.15 | |
| Compatibility | | Mahr VLDT | Tesa | Marposs |

| Order no. | a | b | c | d | e | f | h | i | j | k | l | m | Connection thread |
|-----------|-------|----|----|----|-----|----|----|------|-----|----|-----|------|-------------------|
| | mm | mm | mm | mm | mm | mm | mm | mm | mm | mm | mm | mm | |
| 5324070 | 128.7 | 28 | 37 | 6 | 9.2 | 8 | 14 | 26.5 | 3.6 | 9 | 8.3 | 12.5 | M 2.5 |
| 5324071 | 128.7 | 28 | 37 | 6 | 9.2 | 8 | 14 | 26.5 | 3.6 | 9 | 8.3 | 12.5 | M 2.5 |
| 5324073 | 128.7 | 28 | 37 | 6 | 9.2 | 8 | 14 | 26.5 | 3.6 | 9 | 8.3 | 12.5 | M 2.5 |

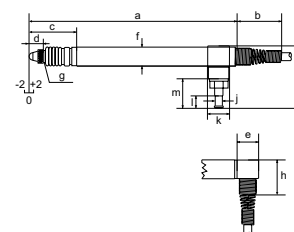

Inductive probe

FEATURES

- Models with pneumatic lifter or vacuum retraction
- Measuring pin mounted in rotary stroke bearing
- High linearity over the entire measuring range
- Excellent electromagnetic shielding (EMC)
- All probes can be easily converted from axial to radial by mounting a slip on cap (included)
- Chemical resistance data:
 - Resistant to oil, gasoline, water and aliphatic compounds
 - Moderately resistant to acids, bases, solvents and ozone
- **Package contains:** instruction manual, cap for radial cable output, spanner for preliminary stroke setting



TECHNICAL DATA

| | Order no. | 5324080 | 5324081 | 5324083 |
|---|------------------------------|--|---------------|----------|
| Type | | P2104 MB | P2104 TB | P2104 UB |
| Measuring range | mm | | ± 2 | |
| Measuring range | inch | | ± .079" | |
| Distance to upper stop | mm...mm | | +8.4 ... 10.4 | |
| Distance to lower stop | mm...mm | | -2.2 ... 0 | |
| Distance to upper stop | inch...inch | | .3341" | |
| Distance to lower stop | inch...inch | | -.09 ... 0" | |
| Lifter / retraction | | Compressed air retraction (max. 1 bar) | | |
| Measuring force | N | Depending upon air pressure | | |
| Sensitivity deviation | % | 0.3 | | |
| Repeatability f_w | μm | 0.2 | | |
| Measuring value hysteresis f_u | μm | 1 | | |
| Linearity deviation within ± 0.5 mm | μm | 0.5 | | |
| Linearity deviation within $\pm .020$ " | inch | 20 μm | | |
| Linearity deviation within ± 1.0 mm | μm | 2 | | |
| Linearity deviation within $\pm .039$ " | inch | 80 μm | | |
| Linearity deviation within ± 2.0 mm | μm | 4 | | |
| Linearity deviation within $\pm .079$ " | inch | 160 μm | | |
| IP protection category | | IP 64 | | |
| Cable length | m | 2.5 | | |
| Temperature coefficient | $\mu\text{m}/^\circ\text{C}$ | 0.15 | | |
| Compatibility | | Mahr VLDT | Tesa | Marposs |

| Order no. | a | b | c | d | e | f | h | i | j | k | l | m | Connection thread |
|-----------|-------|----|----|----|-----|----|----|------|-----|----|-----|------|-------------------|
| | mm | mm | mm | mm | mm | mm | mm | mm | mm | mm | mm | mm | |
| 5324080 | 128.7 | 28 | 37 | 6 | 9.2 | 8 | 14 | 26.5 | 3.6 | 9 | 8.3 | 12.5 | M 2.5 |
| 5324081 | 128.7 | 28 | 37 | 6 | 9.2 | 8 | 14 | 26.5 | 3.6 | 9 | 8.3 | 12.5 | M 2.5 |
| 5324083 | 128.7 | 28 | 37 | 6 | 9.2 | 8 | 14 | 26.5 | 3.6 | 9 | 8.3 | 12.5 | M 2.5 |

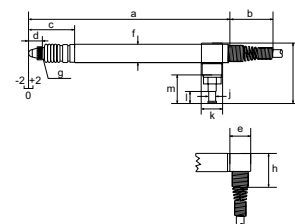

Millimar P2000 series

Inductive probe

ACCESSORIES

| Order no. | For measuring instrument | Description | Type |
|-----------|--|---|---------|
| 5313419 | P2004 MA, P2004 TA, P2004 UA, P2010 UA, P2010 TA, P2010 MA, P2104 UA, P2104 TA, P2104 MA | Pneumatic foot switch for maximum 4 probes | 1340/1F |
| 5313420 | P2004 MA, P2004 TA, P2004 UA, P2010 UA, P2010 TA, P2010 MA, P2104 UA, P2104 TA, P2104 MA | Pneumatic hand lifter for 1 probe | 1340/1 |
| 5323130 | P2104 MB, P2004 MA, P2004 M, P2004 MB, P2010 M, P2010 MA, P2104 MA, P2010 MB | Extension cable 2.5 m (Mahr VLDT) | C2025 M |
| 5323131 | P2104 TB, P2004 T, P2004 TA, P2004 TB, P2010 TA, P2104 TA, P2010 TB | Extension cable 2.5 m (Tesa) | C2025 T |
| 5323140 | P2104 MB, P2004 MA, P2004 M, P2004 MB, P2010 M, P2010 MA, P2104 MA, P2010 MB | Extension cable 5 m (Mahr VLDT) | C2050 M |
| 5323141 | P2104 TB, P2004 T, P2004 TA, P2004 TB, P2010 TA, P2104 TA, P2010 TB | Extension cable 5 m (Tesa) | C2050 T |
| 5323150 | P2104 MB, P2004 MA, P2004 M, P2004 MB, P2010 M, P2010 MA, P2104 MA, P2010 MB | Extension cable 7.5 m (Mahr VLDT) | C2075 M |
| 5323151 | P2104 TB, P2004 T, P2004 TA, P2004 TB, P2010 TA, P2104 TA, P2010 TB | Extension cable 7.5 m (Tesa) | C2075 T |
| 5323160 | P2104 MB, P2004 MA, P2004 M, P2004 MB, P2010 M, P2010 MA, P2104 MA, P2010 MB | Extension cable 10 m (Mahr VLDT) | C2100 M |
| 5323161 | P2104 TB, P2004 T, P2004 TA, P2004 TB, P2010 TA, P2104 TA, P2010 TB | Extension cable 10 m (Tesa) | C2100 T |
| 7021546 | P2004 U, P2004 MA, P2004 T, P2004 M, P2004 TA, P2004 UA | Sealing bellows for probes with measuring spring | |
| 7025505 | P2004 U, P2004 MA, P2004 T, P2004 M, P2004 TA, P2004 UA | Measuring spring 1.25 N | |
| 7025579 | P2004 U, P2004 MA, P2004 T, P2004 M, P2004 TA, P2004 UA | Measuring spring 1.0 N | |
| 7026827 | P2004 U, P2004 MA, P2004 T, P2004 M, P2004 TA, P2004 UA | Measuring spring 0.25 N | |
| 7026828 | P2004 U, P2004 MA, P2004 T, P2004 M, P2004 TA, P2004 UA | Measuring spring 0.5 N | |
| 7026849 | P2004 U, P2004 MA, P2004 T, P2004 M, P2004 TA, P2004 UA | Measuring spring 0.75 N | |
| 7027758 | P2010 UA, P2010 M, P2010 TA, P2010 MA, P2104 UA, P2104 TA, P2104 MA | Sealing bellows long for probes with measuring spring | |
| 7028220 | P2004 MB, P2004 TB, P2004 UB | Sealing bellows for probes with air retraction | |
| 7028221 | P2104 MB, P2104 UB, P2104 TB, P2010 MB, P2010 TB, P2010 UB | Sealing bellows long for probes with air retraction | |

Inductive probe

FEATURES

- Mahr compatibility
- Proven Mahr half-bridge technology
- Very easy to service: cables and probes can be separated via the plug-in connector
- Easy to convert to pneumatic lifting
- Measuring pin mounted in rotary stroke bearing
- Chemical resistance data:
 - Resistant to oil, gasoline, water and aliphatic compounds
 - Moderately resistant to acids, bases, solvents and ozone
- **Package contains:** instruction manual, spanner for preliminary stroke setting, hose connector for compressed air



TECHNICAL DATA

| Order no. | | 4400180 | 4400182 |
|---------------------------------------|------------------------------|---------------------------------|------------------------|
| Type | | P1300 MA | P1300 MA without cable |
| Measuring range | mm | ± 2 | |
| Measuring range | inch | ± .079" | |
| Distance to upper stop | mm...mm | +2.2 ... 4.4 | |
| Distance to lower stop | mm...mm | -2.2 ... 0 | |
| Distance to upper stop | inch...inch | + .09173" | |
| Distance to lower stop | inch...inch | -.09 ... 0" | |
| Lifter / retraction | | Vacuum lifter (standard option) | |
| Measuring force | N | 0.75 N +/- 0.15 N | |
| Increase in measuring force | N/mm | 0.3 N/mm | |
| Sensitivity deviation | % | 0.3 | |
| Repeatability f_w | μm | 0.1 | |
| Measuring value hysteresis f_u | μm | 0.5 | |
| Linearity deviation within +/- 0.5 mm | μm | 0.4 | |
| Linearity deviation within +/- .020" | inch | 16 μm | |
| Linearity deviation within +/- 1.0 mm | μm | 1.5 | |
| Linearity deviation within +/- .039" | inch | 60 μm | |
| Linearity deviation within +/- 2.0 mm | μm | 3 | |
| Linearity deviation within +/- .079" | inch | 120 μm | |
| IP protection category | | IP 64 | |
| Cable length | m | 2.5 | |
| Temperature coefficient | $\mu\text{m}/^\circ\text{C}$ | 0.15 | |
| Compatibility | | Mahr half-bridge | |

| Order no. | a | b | c | d |
|-----------|------|------|------|-----|
| | mm | mm | mm | mm |
| 4400180 | 85.6 | 53.3 | 98.6 | 125 |
| 4400182 | 85.6 | 53.3 | 98.6 | 125 |

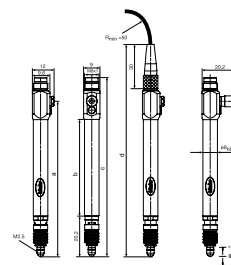

ACCESSORIES

| Order no. | Description |
|-----------|--|
| 4885220 | Cable 2.5 m |
| 4885259 | Cable 5 m |
| 4885260 | Cable 10 m |
| 4885334 | Cable 2.5 m, 90° offset |
| 4885335 | Cable 5 m, 90° offset |
| 4885336 | Cable 10 m, 90° offset |
| 4400238 | Hose connector 90° offset |
| 7021546 | Sealing bellows for probes with measuring spring |
| 7026827 | Measuring spring 0.25 N |
| 7026828 | Measuring spring 0.5 N |
| 7026849 | Measuring spring 0.75 N |
| 7025579 | Measuring spring 1.0 N |
| 7025505 | Measuring spring 1.25 N |

Millimar P1300 MB / P1300 MB without cable



Inductive probe

FEATURES

- Mahr compatibility
- Proven Mahr half-bridge technology
- With compressed-air push
- Very easy to service: cables and probes can be separated via the plug-in connector
- Measuring pin mounted in rotary stroke bearing
- Chemical resistance data:
 - Resistant to oil, gasoline, water and aliphatic compounds
 - Moderately resistant to acids, bases, solvents and ozone
- **Package contains:** instruction manual, spanner for preliminary stroke setting, hose connector for compressed air



TECHNICAL DATA

| Order no. | | 4400181 | 4400183 |
|--|------------------------------|--------------------------------|------------------------|
| Type | | P1300 MB | P1300 MB without cable |
| Measuring range | mm | | ± 2 |
| Measuring range | inch | | ± .079" |
| Distance to upper stop | mm...mm | | +2.2 ... 4.4 |
| Distance to lower stop | mm...mm | | -2.2 ... 0 |
| Distance to upper stop | inch...inch | | + .09173" |
| Distance to lower stop | inch...inch | | -.09 ... 0" |
| Lifter / retraction | | Pneumatic jacking (max. 1 bar) | |
| Measuring force | N | Depending upon air pressure | |
| Sensitivity deviation | % | 0.3 | |
| Repeatability f_w | μm | 0.1 | |
| Measuring value hysteresis f_u | μm | 0.5 | |
| Linearity deviation within ± 0.5 mm | μm | 0.4 | |
| Linearity deviation within ± 0.020 " | inch | 16 μm | |
| Linearity deviation within ± 1.0 mm | μm | 1.5 | |
| Linearity deviation within ± 0.039 " | inch | 60 μm | |
| Linearity deviation within ± 2.0 mm | μm | 3 | |
| Linearity deviation within ± 0.079 " | inch | 120 μm | |
| IP protection category | | IP 64 | |
| Cable length | m | 2.5 | |
| Temperature coefficient | $\mu\text{m}/^\circ\text{C}$ | 0.15 | |
| Compatibility | | Mahr half-bridge | |

| Order no. | a | b | c | d |
|-----------|------|------|------|-----|
| | mm | mm | mm | mm |
| 4400181 | 85.6 | 53.3 | 98.6 | 125 |
| 4400183 | 85.6 | 53.3 | 98.6 | 125 |

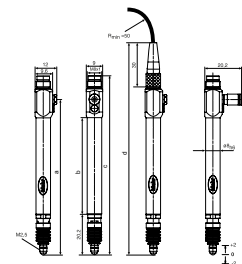

ACCESSORIES

| Order no. | Description |
|-----------|--|
| 4885220 | Cable 2.5 m |
| 4885259 | Cable 5 m |
| 4885260 | Cable 10 m |
| 4885334 | Cable 2.5 m, 90° offset |
| 4885335 | Cable 5 m, 90° offset |
| 4885336 | Cable 10 m, 90° offset |
| 4400238 | Hose connector 90° offset |
| 7028220 | Sealing bellows for probes with air retraction |

Inductive probe

FEATURES

- Tesa compatibility
- Tesa half-bridge technology
- Very easy to service: cables and probes can be separated via the plug-in connector
- Easy to convert to pneumatic lifting
- Measuring pin mounted in rotary stroke bearing
- Chemical resistance data:
 - Resistant to oil, gasoline, water and aliphatic compounds
 - Moderately resistant to acids, bases, solvents and ozone
- **Package contains:** instruction manual, spanner for preliminary stroke setting, hose connector for compressed air



TECHNICAL DATA

| Order no. | 4400190 | | 4400192 | |
|--------------------------------------|---------------------------------|-------------------|------------------------|--|
| Type | P1300 TA | | P1300 TA without cable | |
| Measuring range | mm | ± 2 | | |
| Measuring range | inch | ± .079" | | |
| Distance to upper stop | mm...mm | +2.2 ... 4.4 | | |
| Distance to lower stop | mm...mm | -2.2 ... 0 | | |
| Distance to upper stop | inch...inch | + .09173" | | |
| Distance to lower stop | inch...inch | -.09 ... 0" | | |
| Lifter / retraction | Vacuum lifter (standard option) | | | |
| Measuring force | N | 0.75 N +/-0.15 N | | |
| Increase in measuring force | N/mm | 0.3 N/mm | | |
| Sensitivity deviation | % | 0.3 | | |
| Repeatability f_w | μm | 0.1 | | |
| Measuring value hysteresis f_u | μm | 0.5 | | |
| Linearity deviation within +/-0.5 mm | μm | 1 | | |
| Linearity deviation within +/-0.020" | inch | 40 μm | | |
| Linearity deviation within +/-1.0 mm | μm | 3 | | |
| Linearity deviation within +/-0.039" | inch | 120 μm | | |
| IP protection category | | | IP 64 | |
| Cable length | m | 2.5 | | |
| Temperature coefficient | $\mu\text{m}/^\circ\text{C}$ | 0.15 | | |
| Compatibility | | | Tesa | |

| Order no. | a | b | c | d |
|-----------|------|------|-------|-------|
| | mm | mm | mm | mm |
| 4400190 | 94.2 | 61.9 | 107.2 | 133.6 |
| 4400192 | 94.2 | 61.9 | 107.2 | 133.6 |

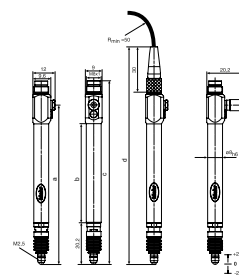

ACCESSORIES

| Order no. | Description |
|-----------|--|
| 4885220 | Cable 2.5 m |
| 4885259 | Cable 5 m |
| 4885260 | Cable 10 m |
| 4885334 | Cable 2.5 m, 90° offset |
| 4885335 | Cable 5 m, 90° offset |
| 4885336 | Cable 10 m, 90° offset |
| 4400238 | Hose connector, 90° offset |
| 7021546 | Sealing bellows for probes with measuring spring |
| 7026827 | Measuring spring 0.25 N |
| 7026828 | Measuring spring 0.5 N |
| 7026849 | Measuring spring 0.75 N |
| 7025579 | Measuring spring 1.0 N |
| 7025505 | Measuring spring 1.25 N |

Millimar P1300 TB / P1300 TB without cable

Inductive probe



FEATURES

- Tesa compatibility
- Tesa half-bridge technology
- With compressed-air push
- Very easy to service: cables and probes can be separated via the plug-in connector
- Measuring pin mounted in rotary stroke bearing
- Chemical resistance data:
 - Resistant to oil, gasoline, water and aliphatic compounds
 - Moderately resistant to acids, bases, solvents and ozone
- **Package contains:** instruction manual, spanner for preliminary stroke setting, hose connector for compressed air



TECHNICAL DATA

| Order no. | | 4400191 | 4400193 |
|--|------------------------------|--|------------------------|
| Type | | P1300 TB | P1300 TB without cable |
| Measuring range | mm | | ± 2 |
| Measuring range | inch | | ± .079" |
| Distance to upper stop | mm...mm | | +2.2 ... 4.4 |
| Distance to lower stop | mm...mm | | -2.2 ... 0 |
| Distance to upper stop | inch...inch | | + .09173" |
| Distance to lower stop | inch...inch | | -.09 ... 0" |
| Lifter / retraction | | Compressed air retraction (max. 1 bar) | |
| Measuring force | N | Depending upon air pressure | |
| Sensitivity deviation | % | 0.3 | |
| Repeatability f_w | μm | 0.1 | |
| Measuring value hysteresis f_u | μm | 0.5 | |
| Linearity deviation within ± 0.5 mm | μm | 1 | |
| Linearity deviation within ± 0.020 " | inch | 40 μm | |
| Linearity deviation within ± 1.0 mm | μm | 3 | |
| Linearity deviation within ± 0.039 " | inch | 120 μm | |
| IP protection category | | IP 64 | |
| Cable length | m | 2.5 | |
| Temperature coefficient | $\mu\text{m}/^\circ\text{C}$ | 0.15 | |
| Compatibility | | Tesa | |

| Order no. | a | b | c | d |
|-----------|------|------|-------|-------|
| | mm | mm | mm | mm |
| 4400191 | 94.2 | 61.9 | 107.2 | 133.6 |
| 4400193 | 94.2 | 61.9 | 107.2 | 133.6 |

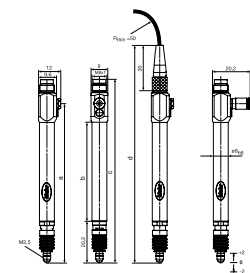

ACCESSORIES

| Order no. | Description |
|-----------|--|
| 4885220 | Cable 2.5 m |
| 4885259 | Cable 5 m |
| 4885260 | Cable 10 m |
| 4885334 | Cable 2.5 m, 90° offset |
| 4885335 | Cable 5 m, 90° offset |
| 4885336 | Cable 10 m, 90° offset |
| 4400238 | Hose connector 90° offset |
| 7028220 | Sealing bellows for probes with air retraction |

FEATURES

- Highly robust as the measuring system is recessed from the guide and mounting shaft
- Outstanding clamping properties
- Measuring pin mounted in rotary stroke bearing
- Measuring pin can be lifted using wire lifter
- Chemical resistance data:
 - Resistant to oil, gasoline, water and aliphatic compounds
 - Moderately resistant to acids, bases, solvents and ozone
- **Package contains:** spanner for preliminary stroke setting



TECHNICAL DATA

| Order no. | | 5313010 | 5313030 |
|--------------------------------------|------------------------------|---------|------------------|
| Type | | 1301 | 1303 |
| Measuring range | mm | | ± 1 |
| Measuring range | inch | | ± .039" |
| Distance to upper stop | mm | | +2,7 |
| Distance to lower stop | mm | | -1.1 ... 0 |
| Distance to upper stop | inch | | + .106" |
| Distance to lower stop | inch | | -.043 ... 0" |
| Lifter / retraction | | | Cable release |
| Measuring force | N | | 0.75 N +/-0.15 N |
| Increase in measuring force | N/mm | | 0.4 N/mm |
| Sensitivity deviation | % | | 0.3 |
| Repeatability f_w | μm | | 0.1 |
| Measuring value hysteresis f_u | μm | | 0.2 |
| Linearity deviation within +/-0.5 mm | μm | | 0.5 |
| Linearity deviation within +/-0.020" | inch | | 20 μm |
| Linearity deviation within +/-1.0 mm | μm | | 2 |
| Linearity deviation within +/-0.039" | inch | | 80 μm |
| IP protection category | | | IP 64 |
| Cable length | m | | 2.5 |
| Temperature coefficient | $\mu\text{m}/^\circ\text{C}$ | | 0.09 |
| Compatibility | | | Mahr LVDT |

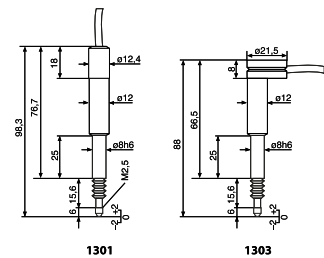

ACCESSORIES

| Order no. | Description | Type |
|-----------|--|----------|
| 5312881 | Extension cable 1 m (Mahr LVDT) | 1288/1 |
| 5312882 | Extension cable 2.5 m (Mahr LVDT) | 1288/2.5 |
| 5312885 | Extension cable 5 m (Mahr LVDT) | 1288/5 |
| 5312887 | Extension cable 7.5 m (Mahr LVDT) | 1288/7.5 |
| 5312889 | Extension cable 10 m (Mahr LVDT) | 1288/10 |
| 5313990 | Cable release with clamp for 1301 / 1303 | 1399 |

Millimar 1304 K

Inductive probe



FEATURES

- Highly robust as the measuring system is recessed from the guide and mounting shaft
- Outstanding clamping properties
- Measuring pin mounted in rotary stroke bearing
- Chemical resistance data:
 - Resistant to oil, gasoline, water and aliphatic compounds
 - Moderately resistant to acids, bases, solvents and ozone

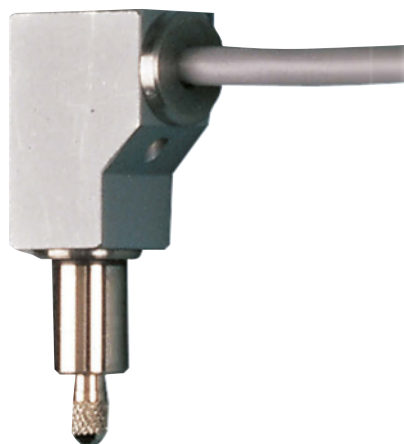

TECHNICAL DATA

| Order no. | 5313049 | |
|--------------------------------------|------------------------------|-------------------|
| Type | | 1304 K |
| Measuring range | mm | ± 1 |
| Measuring range | inch | ± .039" |
| Distance to upper stop | mm | +1.1 |
| Distance to lower stop | mm | 1.1 |
| Distance to upper stop | inch | + .043" |
| Distance to lower stop | inch | -.043" |
| Measuring force | N | 0.75 N +/-0.15 N |
| Increase in measuring force | N/mm | 0.15 N/mm |
| Sensitivity deviation | % | 1 |
| Repeatability f_w | μm | 0.15 |
| Measuring value hysteresis f_u | μm | 0.2 |
| Linearity deviation within +/-0.5 mm | μm | 1 |
| Linearity deviation within +/-0.020" | inch | 40 μm |
| Linearity deviation within +/-1.0 mm | μm | 4 |
| Linearity deviation within +/-0.039" | inch | 160 μm |
| IP protection category | | IP 62 |
| Cable length | m | 2.5 |
| Temperature coefficient | $\mu\text{m}/^\circ\text{C}$ | 0.15 |
| Compatibility | | Mahr LVDT |

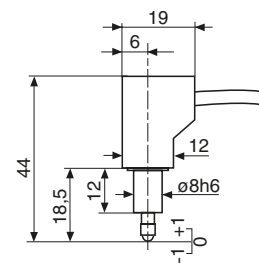

ACCESSORIES

| Order no. | Description | Type |
|-----------|-----------------------------------|----------|
| 5312881 | Extension cable 1 m (Mahr LVDT) | 1288/1 |
| 5312882 | Extension cable 2.5 m (Mahr LVDT) | 1288/2.5 |
| 5312885 | Extension cable 5 m (Mahr LVDT) | 1288/5 |
| 5312887 | Extension cable 7.5 m (Mahr LVDT) | 1288/7.5 |
| 5312889 | Extension cable 10 m (Mahr LVDT) | 1288/10 |

Millimar 1318

Inductive probe

FEATURES

- Dial test indicator inductive probe
- Flexible probe adjustment to contact surface
- Highly robust as the measuring system is recessed from the guide and mounting shaft
- Outstanding clamping properties
- Chemical resistance data:
 - Resistant to oil, gasoline, water and aliphatic compounds
 - Moderately resistant to acids, bases, solvents and ozone



TECHNICAL DATA

| Order no. | | 5313180 |
|--------------------------------------|---------------|--------------------|
| Type | | 1318 |
| Measuring range | mm | -0.3 ... 1 |
| Measuring range | inch | - .012 ... + .039" |
| Distance to upper stop | mm | +1.6 |
| Distance to lower stop | mm | -0.37 |
| Distance to upper stop | inch | + .063" |
| Distance to lower stop | inch | - .0146" |
| Measuring force | N | 0.25 N +/-0.05 N |
| Increase in measuring force | N/mm | 0.04 N/mm |
| Sensitivity deviation | % | 0.5 |
| Repeatability f_w | μm | 0.03 |
| Measuring value hysteresis f_u | μm | 0.5 |
| Linearity deviation within +/-0.3 mm | μm | 0.9 |
| Linearity deviation within +/-0.012" | inch | 36 μm |
| IP protection category | | IP 50 |
| Cable length | m | 1.5 |
| Compatibility | | Mahr LVDT |

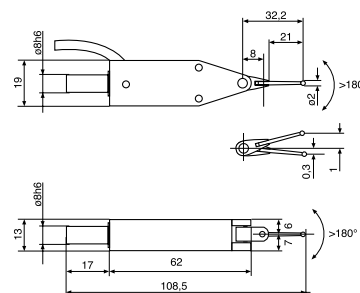

ACCESSORIES

| Order no. | Description | Type |
|-----------|---|----------|
| 5312881 | Extension cable 1 m (Mahr LVDT) | 1288/1 |
| 5312882 | Extension cable 2.5 m (Mahr LVDT) | 1288/2.5 |
| 5312885 | Extension cable 5 m (Mahr LVDT) | 1288/5 |
| 5312887 | Extension cable 7.5 m (Mahr LVDT) | 1288/7.5 |
| 5312889 | Extension cable 10 m (Mahr LVDT) | 1288/10 |
| 7003901 | Stylus \varnothing 0.5 mm, carbide, l = 21 mm | |
| 7003902 | Stylus \varnothing 1.0 mm, carbide, l = 21 mm | |
| 3005223 | Stylus \varnothing 2.0 mm, carbide, l = 21 mm | |
| 7003903 | Stylus \varnothing 3.0 mm, carbide, l = 21 mm | |
| 8004231 | Stylus \varnothing 2.0 mm, ruby, l = 21 mm | |

FEATURES

- Only for use in conjunction with the Millimar C 1240 M compact length measuring instrument, Millimar C 1202 + N 1702 M-HR or Millimar C 1202 + N 1702 M
- Maximum measuring accuracy and minimum linearity deviation <math><0.01\%</math>, i.e. - Probe protected against dirt and moisture, can therefore be used close to production
- Chemical resistance data:
 - Resistant to oil, gasoline, water and aliphatic compounds
 - Moderately resistant to acids, bases, solvents and ozone



TECHNICAL DATA

| Order no. | 5313400 | |
|---|------------------------------|--------------|
| Type | 1340 | |
| Measuring range | mm | ± 2 |
| Measuring range | inch | $\pm .079''$ |
| Distance to upper stop | mm | +3 |
| Distance to lower stop | mm | -2.2 |
| Distance to upper stop | inch | + .118'' |
| Distance to lower stop | inch | -.09'' |
| Lifter / retraction | Vacuum lifter | |
| Measuring force | N | 0.75 N |
| Increase in measuring force | N/mm | 0.08 N/mm |
| Sensitivity deviation | % | 0.3 |
| Repeatability f_w | μm | 0.08 |
| Measuring value hysteresis f_u | μm | 0.08 |
| Linearity deviation within $\pm 1.0\ \text{mm}$ | μm | 0.15 |
| Linearity deviation within $\pm .039''$ | inch | $6\ \mu''$ |
| Linearity deviation within $\pm 2.0\ \text{mm}$ | μm | 0.4 |
| Linearity deviation within $\pm .079''$ | inch | $16\ \mu''$ |
| IP protection category | IP 64 | |
| Cable length | m | 1.5 |
| Temperature coefficient | $\mu\text{m}/^\circ\text{C}$ | 0.6 |
| Compatibility | Mahr 1340 | |

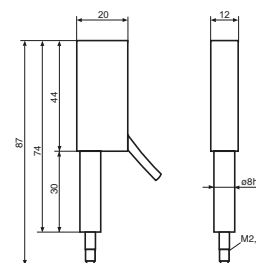

ACCESSORIES

| Order no. | Description | Type |
|-----------|--|---------|
| 5313420 | Pneumatic hand lifter for 1 probe | 1340/1 |
| 5313419 | Pneumatic foot switch for maximum 4 probes | 1340/1F |

Millimar P 1512 V / P 1530 V

Incremental probe

FEATURES

- Maximum measuring accuracy for long measuring length
- Compact dimensions
- Particularly durable ball bearing guide
- Reference mark for position determination
- 8 mm clamping shaft
- **Package contains:** instruction manual, test certificate



TECHNICAL DATA

| Order no. | | 5315081 | 5315311 |
|------------------------|------|--|-----------|
| Type | | P 1512 V | P 1530 V |
| Measuring span | mm | 12 | 30 |
| Measuring span | inch | 0.47 | 1.18 |
| Measuring force | N | 0.6 – 1.2 N | 0.4 – 1 N |
| Maximum shear force | N | 0,8 | |
| Measuring system | | DIADUR-glass scale with incremental graduation | |
| System accuracy | µm | 1.0 | |
| Resolution | | 20 µm | |
| Output signal | | 1 Vpp | |
| Max measuring speed | | 0.5 m/s | |
| IP protection category | | IP 67 | IP 64 |
| Cable length | m | 1.5 | |
| Working temperature | °C | 20 | |

Millimar | Air gage metrology

Metrological characteristics

Millimar evaluation devices work according to the principle of differential pressure measurement. The pressure difference between two pressure chambers is measured. While one of the two chambers supplies a constant reference pressure, the pressure of the other chamber (measuring chamber) is determined by the distance of the measuring nozzles of a pneumatic transducer to the test specimen. Millimar evaluation units have two connection points, each of which is directly connected to one of the two pressure chambers. As a result, the measured value is measured directly via a piezo pressure sensor without conversion and then digitized.

Ratios from 2500:1 to 10000:1 are realized by exchangeable unit nozzles.

Millimar gages must be supplied with constant air pressure via a fine pressure reducer. Gages with a fine pressure reducer can be connected to all compressed air lines with operating pressures from 3.5 bar to 10 bar gage pressure, whereby an air filter should be interposed.

The compressed air must be dry and oil-free.

- Universal, reliable, proven, particularly powerful
- High measuring accuracy and reproducibility of measuring results: 0.5 μm to 2 μm depending on transmission ratio
- Non-contact measurement with measuring nozzles, no damage to workpieces
- Reliable measurement even of uncleaned, oiled, greased or lapped workpieces. Cleaning of the measuring points by the measuring air
- Robust design for workshop use
- Wide range of models for all applications
- Special designs for special applications



Millimar | Air gaging equipment



N 1701 PF-xxx



Jet air ring gage

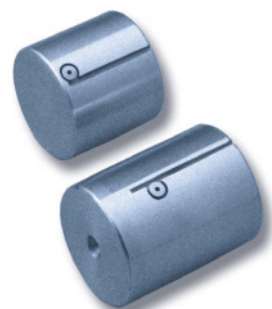

Jet air plug gages

Millimar | Air gages

Precision begins at the start of the measuring process

Air gages use the measuring effect of the change in pressure when a workpiece approaches a measuring jet. As the distance between jets and work surface decreases, the pressure increases while the velocity of flow and the respective volume flow decrease. The air measuring procedure has a relatively short but very linear measuring range.

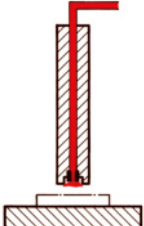
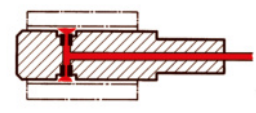
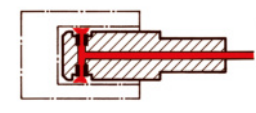
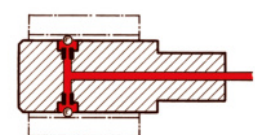
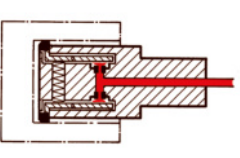
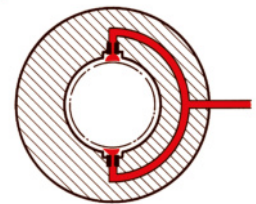
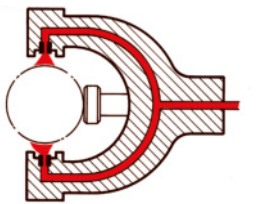
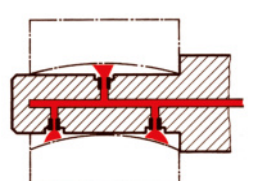
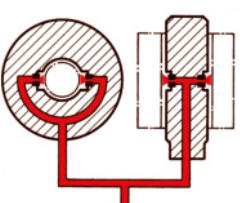
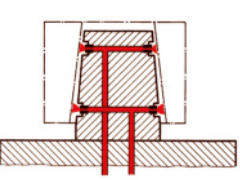
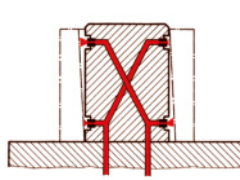
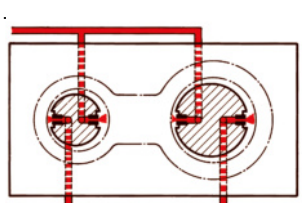
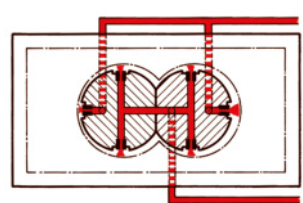
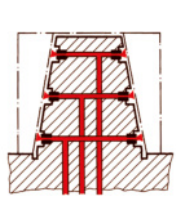
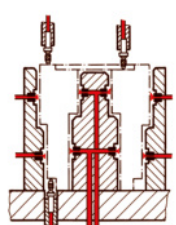
- | | | | |
|---|--|---|--|
| <p>1.</p>  | <p>2.</p>  | <p>3.</p>  | <p>4.</p>  |
| <p>Thickness or wall thickness measurements with jet air gage.</p> | <p>Diameter measurement of cylindrical through bores with jet air plug gage.</p> | <p>Diameter measurement of cylindrical blind bores with jet air plug gage.</p> | <p>Diameter measurement of cylindrical through bores with ball contact plug gage.</p> |
| <p>5.</p>  | <p>6.</p>  | <p>7.</p>  | <p>8.</p>  |
| <p>Diameter measurement of cylindrical blind bores with lever contact plug gage.</p> | <p>Diameter measurement of cylindrical shafts with jet air ring gage.</p> | <p>Diameter or thickness measurement with adjustable jet air caliper gage.</p> | <p>Straightness measurement of a cylindrical bore with special jet air plug gage.</p> |
| <p>9.</p>  | <p>10.</p>  | <p>11.</p>  | <p>12.</p>  |
| <p>Mating measurement between bore and shaft with jet air plug gage and jet air ring gage.</p> | <p>Taper pitch measurement of an inside taper with taper jet air plug gage measurement as per the differential measuring method.</p> | <p>Measurement of a perpendicular position of a cylindrical bore to the front face with a special jet air plug gage measurement as per the differential measuring method.</p> | <p>Measurement of hole distances of separated cylindrical bores with jet air plug gage measurement as per the differential measuring method.</p> |
| <p>13.</p>  | <p>14.</p>  | <p>15.</p>  | |
| <p>Measurement of hole distances of truncated cylindrical bores with jet air plug gages measurement as per the differential measuring method.</p> | <p>Taper pitch measurement as well as form and diameter measurement of an inside taper with taper jet air plug gage.</p> | <p>Multiple inside and outside measurements with measuring jet air gages and contact probes in connection with a seven-column unit.</p> | |

Millimar DP20 / DP50 / DP60

2-jet through-hole air plug gage

FEATURES

- Calibrated ID tooling for the Dimensionair® air gaging systems
- Tooling is interchangeable without adjusting system magnification
- Federal air plugs have large clearance (see table below), allowing easy entrance into the hole being measured and a greater measuring range
- Long life - wide clearance and PVD coated (optional) body extends life of the air plug
- Air jets are recessed into the plug body, protecting them from damage
- Large jet size eliminates clogging from dirt and oils.
- Other lengths for air plug body (L2) and position of measuring jets (B) on request

Application:

- Measurement of through holes

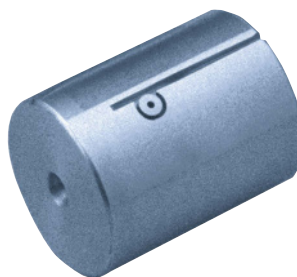

Please always state when ordering:

- Transmission ratio of the display unit (e.g. DP50 / 2500:1)
- The nominal size to be measured
- The specified workpiece tolerance
- Whether the air plug body is to be finished without or with PVD coating

TECHNICAL DATA

| Order no. | Type | Nominal size | Nominal size | Model | Magnification | Measuring span | Compatibility | Connection thread | Minimum bore length | Including handle |
|------------|------|--------------|--------------|---------------------------|------------------------------|--|---------------|-------------------|---------------------|------------------|
| | | mm | inch | | | | | | mm | |
| 2115000 | DP20 | 3.000 | .118-.236" | hardened steel | 5000:1, 2500:1, 1260:1 | 13-25 (DP20) 25-51 (DP50) 51-102 (DP60) depending on diameter | Federal | 3/8"-32 | 4.75 | |
| | DP50 | -6.000 | | | | | | | | |
| | DP60 | | | | | | | | | |
| 2115000PVD | DP20 | 3.000 | .118-.236" | PVD coated based on AlCrN | 5000:1, 2500:1, 1260:1 | 13-25 (DP20) 25-51 (DP50) 51-102 (DP60) depending on diameter | Federal | 3/8"-32 | 4.75 | |
| | DP50 | -6.000 | | | | | | | | |
| | DP60 | | | | | | | | | |
| 2115001 | DP20 | 6.000 | .236-.394" | hardened steel | 5000:1, 2500:1, 1260:1 | 38 (DP20) 76 (DP50) 152 (DP60) | Federal | 3/8"-32 | 6.35 | |
| | DP50 | -10.000 | | | | | | | | |
| | DP60 | | | | | | | | | |
| 2115001PVD | DP20 | 6.000 | .236-.394" | PVD coated based on AlCrN | 5000:1, 2500:1, 1260:1 | 38 (DP20) 76 (DP50) 152 (DP60) | Federal | 3/8"-32 | 6.35 | |
| | DP50 | -10.000 | | | | | | | | |
| | DP60 | | | | | | | | | |
| 2115002 | DP20 | 10.000 | .394-.512" | hardened steel | 5000:1, 2500:1, 1260:1 | 38 (DP20) 76 (DP50) 152 (DP60) | Federal | 3/8"-32 | 6.35 | |
| | DP50 | -13.000 | | | | | | | | |
| | DP60 | | | | | | | | | |
| 2115002PVD | DP20 | 10.000 | .394-.512" | PVD coated based on AlCrN | 5000:1, 2500:1, 1260:1 | 38 (DP20) 76 (DP50) 152 (DP60) | Federal | 3/8"-32 | 6.35 | |
| | DP50 | -13.000 | | | | | | | | |
| | DP60 | | | | | | | | | |
| 2115003 | DP20 | 13.000 | .512-.590" | hardened steel | 5000:1, 2500:1, 1260:1 | 38 (DP20) 76 (DP50) 152 (DP60) | Federal | 3/8"-32 | 6.35 | |
| | DP50 | -15.000 | | | | | | | | |
| | DP60 | | | | | | | | | |
| 2115003PVD | DP20 | 13.000 | .512-.590" | PVD coated based on AlCrN | 5000:1, 2500:1, 1260:1 | 38 (DP20) 76 (DP50) 152 (DP60) | Federal | 3/8"-32 | 6.35 | |
| | DP50 | -15.000 | | | | | | | | |
| | DP60 | | | | | | | | | |
| 2115004 | DP20 | 15.000 | .590-1.575" | hardened steel | 5000:1, 2500:1, 1260:1 | 38 (DP20) 76 (DP50) 152 (DP60) | Federal | 3/8"-32 | 6.35 | |
| | DP50 | -40.000 | | | | | | | | |
| | DP60 | | | | | | | | | |
| 2115004PVD | DP20 | 15.000 | .590-1.575" | PVD coated based on AlCrN | 5000:1, 2500:1, 1260:1 | 38 (DP20) 76 (DP50) 152 (DP60) | Federal | 3/8"-32 | 6.35 | |
| | DP50 | -40.000 | | | | | | | | |
| | DP60 | | | | | | | | | |
| 2115005 | DP20 | 40.000 | 1.575-2.362" | hardened steel | 5000:1, 2500:1, 1260:1 | 38 (DP20) 76 (DP50) 152 (DP60) | Federal | 3/8"-32 | 6.35 | |
| | DP50 | -60.000 | | | | | | | | |
| | DP60 | | | | | | | | | |
| 2115005PVD | DP20 | 40.000 | 1.575-2.362" | PVD coated based on AlCrN | 5000:1, 2500:1, 1260:1 | 38 (DP20) 76 (DP50) 152 (DP60) | Federal | 3/8"-32 | 6.35 | |
| | DP50 | -60.000 | | | | | | | | |
| | DP60 | | | | | | | | | |

Millimar DP20 / DP50 / DP60

2-jet through-hole air plug gage

| Order no. | Type | Nominal size | Nominal size | Model | Magnification | Measuring span | Compatibility | Connection thread | Minimum bore length | Including handle |
|------------|----------------------|---------------------|--------------|---------------------------|------------------------------|--------------------------------------|---------------|-------------------|---------------------|------------------|
| | | mm | inch | | | µm | | | mm | |
| 2115006 | DP20 DP50 DP60 | 60.000 -75.000 | 2.362-2.953" | hardened steel | 5000:1, 2500:1, 1260:1 | 38 (DP20) 76 (DP50) 152 (DP60) | Mahr | 3/8"-32 | 6.35 | |
| 2115006PVD | DP20 DP50 DP60 | 60.000 -75.000 | 2.362-2.953" | PVD coated based on AlCrN | 5000:1, 2500:1, 1260:1 | 38 (DP20) 76 (DP50) 152 (DP60) | Mahr | 3/8"-32 | 6.35 | |
| 2115027 | DP20 DP50 DP60 | 75.000 -90.000 | 2.953-3.543" | hardened steel | 5000:1, 2500:1, 1260:1 | 38 (DP20) 76 (DP50) 152 (DP60) | Mahr | 3/8"-32 | 6.35 | • |
| 2115027PVD | DP20 DP50 DP60 | 75.000 -90.000 | 2.953-3.543" | PVD coated based on AlCrN | 5000:1, 2500:1, 1260:1 | 38 (DP20) 76 (DP50) 152 (DP60) | Mahr | 3/8"-32 | 6.35 | • |
| 2115028 | DP20 DP50 DP60 | 90.000 -100.000 | 3.543-3.937" | hardened steel | 5000:1, 2500:1, 1260:1 | 38 (DP20) 76 (DP50) 152 (DP60) | Mahr | 3/8"-32 | 6.35 | • |
| 2115028PVD | DP20 DP50 DP60 | 90.000 -100.000 | 3.543-3.937" | PVD coated based on AlCrN | 5000:1, 2500:1, 1260:1 | 38 (DP20) 76 (DP50) 152 (DP60) | Mahr | 3/8"-32 | 6.35 | • |
| 2115029 | DP20 DP50 DP60 | 100.000 -115.000 | 3.937-4.528" | hardened steel | 5000:1, 2500:1, 1260:1 | 38 (DP20) 76 (DP50) 152 (DP60) | Mahr | 3/8"-32 | 6.35 | • |
| 2115029PVD | DP20 DP50 DP60 | 100.000 -115.000 | 3.937-4.528" | PVD coated based on AlCrN | 5000:1, 2500:1, 1260:1 | 38 (DP20) 76 (DP50) 152 (DP60) | Mahr | 3/8"-32 | 6.35 | • |

Millimar DP20 / DP50 / DP60

2-jet through-hole air plug gage

| Order no. | A | B | L ₂ | Nominal size | Nominal size | Connection thread |
|------------|------|-------|----------------|-------------------|--------------|-------------------|
| | mm | mm | mm | mm | inch | |
| 2115000 | 38.1 | 12.70 | 25.4 | 3.000 – 6.000 | .118 – .236" | 3/8"–32 |
| 2115000PVD | 38.1 | 12.70 | 25.4 | 3.000 – 6.000 | .118 – .236" | 3/8"–32 |
| 2115001 | 38.1 | 12.70 | 25.4 | 6.000 – 10.000 | .236–.394" | 3/8"–32 |
| 2115001PVD | 38.1 | 12.70 | 25.4 | 6.000 – 10.000 | .236–.394" | 3/8"–32 |
| 2115002 | 38.1 | 12.70 | 25.4 | 10.000 – 13.000 | .394–.512" | 3/8"–32 |
| 2115002PVD | 38.1 | 12.70 | 25.4 | 10.000 – 13.000 | .394–.512" | 3/8"–32 |
| 2115003 | 44.5 | 19.10 | 25.4 | 13.000 – 15.000 | .512–.590" | 3/8"–32 |
| 2115003PVD | 44.5 | 19.10 | 25.4 | 13.000 – 15.000 | .512–.590" | 3/8"–32 |
| 2115004 | 44.5 | 19.10 | 25.4 | 15.000 – 40.000 | .590–1.575" | 3/8"–32 |
| 2115004PVD | 44.5 | 19.10 | 25.4 | 15.000 – 40.000 | .590–1.575" | 3/8"–32 |
| 2115005 | 44.5 | 19.10 | 25.4 | 40.000 – 60.000 | 1.575–2.362" | 3/8"–32 |
| 2115005PVD | 44.5 | 19.10 | 25.4 | 40.000 – 60.000 | 1.575–2.362" | 3/8"–32 |
| 2115006 | 44.5 | 19.10 | 25.4 | 60.000 – 75.000 | 2.362–2.953" | 3/8"–32 |
| 2115006PVD | 44.5 | 19.10 | 25.4 | 60.000 – 75.000 | 2.362–2.953" | 3/8"–32 |
| 2115027 | 44.5 | 19.10 | 25.4 | 75.000 – 90.000 | 2.953–3.543" | 3/8"–32 |
| 2115027PVD | 44.5 | 19.10 | 25.4 | 75.000 – 90.000 | 2.953–3.543" | 3/8"–32 |
| 2115028 | 44.5 | 19.10 | 25.4 | 90.000 – 100.000 | 3.543–3.937" | 3/8"–32 |
| 2115028PVD | 44.5 | 19.10 | 25.4 | 90.000 – 100.000 | 3.543–3.937" | 3/8"–32 |
| 2115029 | 44.5 | 19.10 | 25.4 | 100.000 – 115.000 | 3.937–4.528" | 3/8"–32 |
| 2115029PVD | 44.5 | 19.10 | 25.4 | 100.000 – 115.000 | 3.937–4.528" | 3/8"–32 |

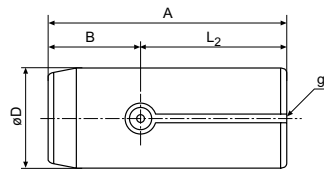

ACCESSORIES

| Order no. | Description | Type | Connection thread |
|-----------|--|-------|-------------------|
| 2260835 | Connecting hose set, complete, 2 m | | 3/8"–32 |
| 2261280 | Connecting hose set, complete, 4 m | | 3/8"–32 |
| 2202010 | Extension for nominal sizes up to 76.3 mm, D = 12 mm, L = 102 mm | AHA-4 | 3/8"–32 |
| 2202011 | Extension for nominal sizes up to 76.3 mm, D = 12 mm, L = 51 mm | AHA-5 | 3/8"–32 |
| 2237666 | Standard plastic handle | | 3/8"–32 |
| 2237873 | Depth stop ring for Mahr nozzle plug gage | | |
| 2239307 | Universal bench mount | | 3/8"–32 |
| 2240993 | Shut off slide valve | | 3/8"–32 |



Millimar DP20 / DP50 / DP60

2-jet blind-hole air plug gage

FEATURES

- Calibrated ID tooling for the Dimensionair® air gaging systems
- Tooling is interchangeable without adjusting system magnification
- Federal air plugs have large clearance (see table below), allowing easy entrance into the hole being measured and a greater measuring range
- Long life - wide clearance and PVD coated (optional) body extends life of the air plug
- Air jets are recessed into the plug body, protecting them from damage
- Large jet size eliminates clogging from dirt and oils
- Other lengths for air plug body (L2) and position of measuring jets (B) on request

Please always state when ordering:

- Transmission ratio of the display unit (e.g. DP50 / 2500:1)
- The nominal size to be measured
The specified workpiece tolerance
- Whether the air plug body is to be finished without or with PVD coating

Application:

- Measurement of blind holes

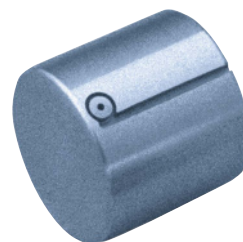

TECHNICAL DATA

| Order no. | Type | Nominal size | Nominal size | Model | Magnification | Measuring span | Compatibility | Connection thread | Minimum bore length | Including handle |
|------------|------|--------------|--------------|---------------------------|------------------------------|--|---------------|-------------------|---------------------|------------------|
| | | mm | inch | | | µm | | | mm | |
| 2115007 | DP20 | 3.000 | .118 | hardened steel | 5000:1, 2500:1, 1260:1 | 13 –25 (DP20) 25 –51 (DP50) 51 –102 (DP60) depending on diameter | Federal | 3/8"–32 | 6.35 | |
| | DP50 | –6.000 | –.236" | | | | | | | |
| | DP60 | | | | | | | | | |
| 2115007PVD | DP20 | 3.000 | .118 | PVD coated based on AlCrN | 5000:1, 2500:1, 1260:1 | 13 –25 (DP20) 25 –51 (DP50) 51 –102 (DP60) depending on diameter | Federal | 3/8"–32 | 6.35 | |
| | DP50 | –6.000 | –.236" | | | | | | | |
| | DP60 | | | | | | | | | |
| 2115008 | DP20 | 6.000 | .236 | hardened steel | 5000:1, 2500:1, 1260:1 | 38 (DP20) 76 (DP50) 152 (DP60) | Federal | 3/8"–32 | 6.35 | |
| | DP50 | –10.000 | –.394" | | | | | | | |
| | DP60 | | | | | | | | | |
| 2115008PVD | DP20 | 6.000 | .236 | PVD coated based on AlCrN | 5000:1, 2500:1, 1260:1 | 38 (DP20) 76 (DP50) 152 (DP60) | Federal | 3/8"–32 | 6.35 | |
| | DP50 | –10.000 | –.394" | | | | | | | |
| | DP60 | | | | | | | | | |
| 2115009 | DP20 | 10.000 | .394 | hardened steel | 5000:1, 2500:1, 1260:1 | 38 (DP20) 76 (DP50) 152 (DP60) | Federal | 3/8"–32 | 6.35 | |
| | DP50 | –13.000 | –.512" | | | | | | | |
| | DP60 | | | | | | | | | |
| 2115009PVD | DP20 | 10.000 | .394 | PVD coated based on AlCrN | 5000:1, 2500:1, 1260:1 | 38 (DP20) 76 (DP50) 152 (DP60) | Federal | 3/8"–32 | 6.35 | |
| | DP50 | –13.000 | –.512" | | | | | | | |
| | DP60 | | | | | | | | | |
| 2115010 | DP20 | 13.000 | .512 | hardened steel | 5000:1, 2500:1, 1260:1 | 38 (DP20) 76 (DP50) 152 (DP60) | Federal | 3/8"–32 | 6.35 | |
| | DP50 | –15.000 | –.590" | | | | | | | |
| | DP60 | | | | | | | | | |
| 2115010PVD | DP20 | 13.000 | .512 | PVD coated based on AlCrN | 5000:1, 2500:1, 1260:1 | 38 (DP20) 76 (DP50) 152 (DP60) | Federal | 3/8"–32 | 6.35 | |
| | DP50 | –15.000 | –.590" | | | | | | | |
| | DP60 | | | | | | | | | |
| 2115011 | DP20 | 15.000 | .590 | hardened steel | 5000:1, 2500:1, 1260:1 | 38 (DP20) 76 (DP50) 152 (DP60) | Federal | 3/8"–32 | 6.35 | |
| | DP50 | –40.000 | –1.575" | | | | | | | |
| | DP60 | | | | | | | | | |
| 2115011PVD | DP20 | 15.000 | .590 | PVD coated based on AlCrN | 5000:1, 2500:1, 1260:1 | 38 (DP20) 76 (DP50) 152 (DP60) | Federal | 3/8"–32 | 6.35 | |
| | DP50 | –40.000 | –1.575" | | | | | | | |
| | DP60 | | | | | | | | | |
| 2115012 | DP20 | 40.000 | 1.575 | hardened steel | 5000:1, 2500:1, 1260:1 | 38 (DP20) 76 (DP50) 152 (DP60) | Federal | 3/8"–32 | 6.35 | |
| | DP50 | –60.000 | –2.362" | | | | | | | |
| | DP60 | | | | | | | | | |
| 2115012PVD | DP20 | 40.000 | 1.575 | PVD coated based on AlCrN | 5000:1, 2500:1, 1260:1 | 38 (DP20) 76 (DP50) 152 (DP60) | Federal | 3/8"–32 | 6.35 | |
| | DP50 | –60.000 | –2.362" | | | | | | | |
| | DP60 | | | | | | | | | |
| 2115013 | DP20 | 60.000 | 2.362 | hardened steel | 5000:1, 2500:1, 1260:1 | 38 (DP20) 76 (DP50) 152 (DP60) | Federal | 3/8"–32 | 6.35 | |
| | DP50 | –75.000 | –2.953" | | | | | | | |
| | DP60 | | | | | | | | | |
| 2115013PVD | DP20 | 60.000 | 2.362 | PVD coated based on AlCrN | 5000:1, 2500:1, 1260:1 | 38 (DP20) 76 (DP50) 152 (DP60) | Federal | 3/8"–32 | 6.35 | |
| | DP50 | –75.000 | –2.953" | | | | | | | |
| | DP60 | | | | | | | | | |
| 2115030 | DP20 | 75.000 | 2.953 | hardened steel | 5000:1, 2500:1, 1260:1 | 38 (DP20) 76 (DP50) 152 (DP60) | Federal | 3/8"–32 | 6.35 | • |
| | DP50 | –90.000 | –3.543" | | | | | | | |
| | DP60 | | | | | | | | | |
| 2115030PVD | DP20 | 75.000 | 2.953 | PVD coated based on AlCrN | 5000:1, 2500:1, 1260:1 | 38 (DP20) 76 (DP50) 152 (DP60) | Federal | 3/8"–32 | 6.35 | • |
| | DP50 | –90.000 | –3.543" | | | | | | | |
| | DP60 | | | | | | | | | |

Millimar DP20 / DP50 /DP60

2-jet blind-hole air plug gage

| Order no. | Type | Nominal size | | Model | Magnification | Measuring span | Compatibility | Connection thread | Minimum bore length | Including handle |
|------------|------|--------------|---------|---------------------------|------------------------------|--------------------------------------|---------------|-------------------|---------------------|------------------|
| | | mm | inch | | | | | | | |
| 2115031 | DP20 | 90.000 | 3.543 | hardened steel | 5000:1, 2500:1, 1260:1 | 38 (DP20) 76 (DP50) 152 (DP60) | Federal | 3/8"-32 | 6.35 | • |
| | DP50 | -100.000 | -3.937" | | | | | | | |
| | DP60 | | | | | | | | | |
| 2115031PVD | DP20 | 90.000 | 3.543 | PVD coated based on AlCrN | 5000:1, 2500:1, 1260:1 | 38 (DP20) 76 (DP50) 152 (DP60) | Federal | 3/8"-32 | 6.35 | • |
| | DP50 | -100.000 | -3.937" | | | | | | | |
| | DP60 | | | | | | | | | |
| 2115032 | DP20 | 100.000 | 3.937 | hardened steel | 5000:1, 2500:1, 1260:1 | 38 (DP20) 76 (DP50) 152 (DP60) | Federal | 3/8"-32 | 6.35 | • |
| | DP50 | -115.000 | -4.528" | | | | | | | |
| | DP60 | | | | | | | | | |
| 2115032PVD | DP20 | 100.000 | 3.937 | PVD coated based on AlCrN | 5000:1, 2500:1, 1260:1 | 38 (DP20) 76 (DP50) 152 (DP60) | Federal | 3/8"-32 | 6.35 | • |
| | DP50 | -115.000 | -4.528" | | | | | | | |
| | DP60 | | | | | | | | | |

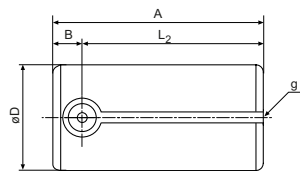

| Order no. | A | B | L ₂ | Nominal size | Nominal size | Connection thread |
|------------|------|------|----------------|-----------------|--------------|-------------------|
| | mm | mm | mm | mm | inch | |
| 2115007 | 29.4 | 4.00 | 25.4 | 3.000-6.000 | .118-.236" | 3/8"-32 |
| 2115007PVD | 29.4 | 4.00 | 25.4 | 3.000-6.000 | .118-.236" | 3/8"-32 |
| 2115008 | 29.4 | 4.00 | 25.4 | 6.000-10.000 | .236-.394" | 3/8"-32 |
| 2115008PVD | 29.4 | 4.00 | 25.4 | 6.000-10.000 | .236-.394" | 3/8"-32 |
| 2115009 | 29.4 | 4.00 | 25.4 | 10.000-13.000 | .394-.512" | 3/8"-32 |
| 2115009PVD | 29.4 | 4.00 | 25.4 | 10.000-13.000 | .394-.512" | 3/8"-32 |
| 2115010 | 29.4 | 4.00 | 25.4 | 13.000-15.000 | .512-.590" | 3/8"-32 |
| 2115010PVD | 29.4 | 4.00 | 25.4 | 13.000-15.000 | .512-.590" | 3/8"-32 |
| 2115011 | 29.4 | 4.00 | 25.4 | 15.000-40.000 | .590-1.575" | 3/8"-32 |
| 2115011PVD | 29.4 | 4.00 | 25.4 | 15.000-40.000 | .590-1.575" | 3/8"-32 |
| 2115012 | 29.4 | 4.00 | 25.4 | 40.000-60.000 | 1.575-2.362" | 3/8"-32 |
| 2115012PVD | 29.4 | 4.00 | 25.4 | 40.000-60.000 | 1.575-2.362" | 3/8"-32 |
| 2115013 | 29.4 | 4.00 | 25.4 | 60.000-75.000 | 2.362-2.953" | 3/8"-32 |
| 2115013PVD | 29.4 | 4.00 | 25.4 | 60.000-75.000 | 2.362-2.953" | 3/8"-32 |
| 2115030 | 29.4 | 4.00 | 25.4 | 75.000-90.000 | 2.953-3.543" | 3/8"-32 |
| 2115030PVD | 29.4 | 4.00 | 25.4 | 75.000-90.000 | 2.953-3.543" | 3/8"-32 |
| 2115031 | 29.4 | 4.00 | 25.4 | 90.000-100.000 | 3.543-3.937" | 3/8"-32 |
| 2115031PVD | 29.4 | 4.00 | 25.4 | 90.000-100.000 | 3.543-3.937" | 3/8"-32 |
| 2115032 | 29.4 | 4.00 | 25.4 | 100.000-115.000 | 3.937-4.528" | 3/8"-32 |
| 2115032PVD | 29.4 | 4.00 | 25.4 | 100.000-115.000 | 3.937-4.528" | 3/8"-32 |

ACCESSORIES

| Order no. | Description | Type | Connection thread |
|-----------|--|-------|-------------------|
| 2260835 | Connecting hose set, complete, 2 m | | 3/8"-32 |
| 2261280 | Connecting hose set, complete, 4 m | | 3/8"-32 |
| 2202010 | Extension for nominal sizes up to 76.3 mm, D = 12 mm, L = 102 mm | AHA-4 | 3/8"-32 |
| 2202011 | Extension for nominal sizes up to 76.3 mm, D = 12 mm, L = 51 mm | AHA-5 | 3/8"-32 |
| 2237666 | Standard plastic handle | | 3/8"-32 |
| 2237873 | Depth stop ring for Mahr nozzle plug gage | | |
| 2239307 | Universal bench mount | | 3/8"-32 |
| 2240993 | Shut off slide valve | | 3/8"-32 |

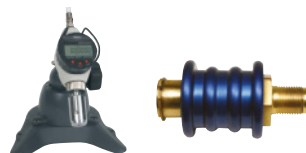

Millimar DR50 / DR20

2-jet air ring gage

FEATURES

- Mahr / Mahr Federal nozzle ring gages have a large clearance tolerance. This allows larger measuring ranges and the workpiece can be inserted more easily into the nozzle ring for measuring.
- Due to a larger plug gage spacing and (optional) hard chrome-plated finish to the body, the nozzle ring gage has a long service life
- The recessed measuring nozzles are located deep in the body of the ring gage, protecting them from damage
- Large nozzle dimensions prevent clogging with dirt and oil
- **When ordering always specify:** Magnification of the display unit (e.g. 2500:1), nominal dimension to be measured and the specified workpiece tolerance



TECHNICAL DATA

| Order no. | Type | Nominal size | | Model | Magnification | Measuring span | Compati- bility |
|-----------|------|----------------|-----------------|----------------|---------------|----------------|-----------------|
| | | mm | inch | | | | |
| 2093005 | DR50 | 6.299 –7.592 | .2480 –.3000 | hardened steel | 2500:1 | 76 | Federal |
| 2093006 | DR50 | 7.595 –9.294 | .3001 –.3650 | hardened steel | 2500:1 | 76 | Federal |
| 2093007 | DR50 | 9.296 –13.002 | .3651 –.5100 | hardened steel | 2500:1 | 76 | Federal |
| 2093008 | DR50 | 13.005 –21.003 | .5101 –.8250 | hardened steel | 2500:1 | 76 | Federal |
| 2093009 | DR50 | 21.006 –25.400 | .8251 –1.0000 | hardened steel | 2500:1 | 76 | Federal |
| 2093010 | DR50 | 25.403 –38.351 | 1.0001 –1.5100 | hardened steel | 2500:1 | 76 | Federal |
| 2093011 | DR50 | 38.354 –44.450 | 1.5101 –1.7500 | hardened steel | 2500:1 | 76 | Federal |
| 2093012 | DR50 | 44.453 –50.797 | 1.75001 –2.0000 | hardened steel | 2500:1 | 76 | Federal |
| 2093013 | DR50 | 50.800 –63.500 | 2.0001 –2.5000 | hardened steel | 2500:1 | 76 | Federal |
| 2093025 | DR20 | 6.299 –7.592 | .2480 –.3000 | hardened steel | 5000:1 | 38 | Federal |
| 2093026 | DR20 | 7.595 –9.294 | .3001 –.3650 | hardened steel | 5000:1 | 38 | Federal |
| 2093027 | DR20 | 9.296 –13.002 | .3651 –.5100 | hardened steel | 5000:1 | 38 | Federal |
| 2093028 | DR20 | 13.005 –21.003 | .5101 –.8250 | hardened steel | 5000:1 | 38 | Federal |
| 2093029 | DR20 | 21.006 –25.400 | .8251 –1.0000 | hardened steel | 5000:1 | 38 | Federal |
| 2093030 | DR20 | 25.403 –38.351 | 1.0001 –1.5100 | hardened steel | 5000:1 | 38 | Federal |
| 2093031 | DR20 | 38.354 –44.450 | 1.5101 –1.7500 | hardened steel | 5000:1 | 38 | Federal |
| 2093032 | DR20 | 44.453 –50.797 | 1.75001 –2.0000 | hardened steel | 5000:1 | 38 | Federal |
| 2093033 | DR20 | 50.800 –63.500 | 2.0001 –2.5000 | hardened steel | 5000:1 | 38 | Federal |

| Order no. | B | D | Nominal size | |
|-----------|-------|-------|----------------|-----------------|
| | mm | mm | mm | inch |
| 2093005 | 25.40 | 76,2 | 6.299 –7.592 | .2480 –.3000 |
| 2093006 | 25.40 | 76,2 | 7.595 –9.294 | .3001 –.3650 |
| 2093007 | 25.40 | 76,2 | 9.296 –13.002 | .3651 –.5100 |
| 2093008 | 25.40 | 76,2 | 13.005 –21.003 | .5101 –.8250 |
| 2093009 | 25.40 | 76,2 | 21.006 –25.400 | .8251 –1.0000 |
| 2093010 | 25.40 | 101.6 | 25.403 –38.351 | 1.0001 –1.5100 |
| 2093011 | 25.40 | 101.6 | 38.354 –44.450 | 1.5101 –1.7500 |
| 2093012 | 25.40 | 127 | 44.453 –50.797 | 1.75001 –2.0000 |
| 2093013 | 25.40 | 127 | 50.800 –63.500 | 2.0001 –2.5000 |
| 2093025 | 25.40 | 76,2 | 6.299 –7.592 | .2480 –.3000 |
| 2093026 | 25.40 | 76,2 | 7.595 –9.294 | .3001 –.3650 |
| 2093027 | 25.40 | 76,2 | 9.296 –13.002 | .3651 –.5100 |
| 2093028 | 25.40 | 76,2 | 13.005 –21.003 | .5101 –.8250 |
| 2093029 | 25.40 | 76,2 | 21.006 –25.400 | .8251 –1.0000 |
| 2093030 | 25.40 | 101.6 | 25.403 –38.351 | 1.0001 –1.5100 |
| 2093031 | 25.40 | 101.6 | 38.354 –44.450 | 1.5101 –1.7500 |
| 2093032 | 25.40 | 127 | 44.453 –50.797 | 1.75001 –2.0000 |
| 2093033 | 25.40 | 127 | 50.800 –63.500 | 2.0001 –2.5000 |

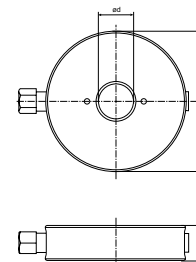

ACCESSORIES

| Order no. | Description | Connection thread |
|-----------|------------------------------------|-------------------|
| 2260835 | Connecting hose set, complete, 2 m | 3/8"–32 |
| 2237666 | Standard plastic handle | 3/8"–32 |
| 2240993 | Shut off slide valve | 3/8"–32 |
| 2239307 | Universal bench mount | 3/8"–32 |



Millimar DR50-3 / DR20-3

3-jet air ring gage

FEATURES

- Mahr / Mahr Federal nozzle ring gages have a large clearance tolerance. This allows larger measuring ranges and the workpiece can be inserted more easily into the nozzle ring for measuring.
- Due to a larger plug gage spacing and (optional) hard chrome-plated finish to the body, the nozzle ring gage has a long service life
- The recessed measuring nozzles are located deep in the body of the ring gage, protecting them from damage
- Large nozzle dimensions prevent clogging with dirt and oil
- **When ordering always specify:** Magnification of the display unit (e.g. 2500:1), nominal dimension to be measured and the specified workpiece tolerance



TECHNICAL DATA

| Order no. | Type | Nominal size | | Model | Magnification | Measuring span | Compatibility |
|-----------|--------|-----------------|------------------|----------------|---------------|----------------|---------------|
| | | mm | inch | | | | |
| 2093015 | DR50-3 | 6.299 - 7.592 | .2480 - .3000 | hardened steel | 2500:1 | 76 | Federal |
| 2093016 | DR50-3 | 7.595 - 9.294 | .3001 - .3650 | hardened steel | 2500:1 | 76 | Federal |
| 2093017 | DR50-3 | 9.296 - 13.002 | .3651 - .5100 | hardened steel | 2500:1 | 76 | Federal |
| 2093018 | DR50-3 | 13.005 - 21.003 | .5101 - .8250 | hardened steel | 2500:1 | 76 | Federal |
| 2093019 | DR50-3 | 21.006 - 25.400 | .8251 - 1.0000 | hardened steel | 2500:1 | 76 | Federal |
| 2093020 | DR50-3 | 25.403 - 38.351 | 1.0001 - 1.5100 | hardened steel | 2500:1 | 76 | Federal |
| 2093021 | DR50-3 | 38.354 - 44.450 | 1.5101 - 1.7500 | hardened steel | 2500:1 | 76 | Federal |
| 2093022 | DR50-3 | 44.453 - 50.797 | 1.75001 - 2.0000 | hardened steel | 2500:1 | 76 | Federal |
| 2093023 | DR50-3 | 50.800 - 63.500 | 2.0001 - 2.5000 | hardened steel | 2500:1 | 76 | Federal |
| 2093035 | DR20-3 | 6.299 - 7.592 | .2480 - .3000 | hardened steel | 5000:1 | 38 | Federal |
| 2093036 | DR20-3 | 7.595 - 9.294 | .3001 - .3650 | hardened steel | 5000:1 | 38 | Federal |
| 2093037 | DR20-3 | 9.296 - 13.002 | .3651 - .5100 | hardened steel | 5000:1 | 38 | Federal |
| 2093038 | DR20-3 | 13.005 - 21.003 | .5101 - .8250 | hardened steel | 5000:1 | 38 | Federal |
| 2093039 | DR20-3 | 21.006 - 25.400 | .8251 - 1.0000 | hardened steel | 5000:1 | 38 | Federal |
| 2093040 | DR20-3 | 25.403 - 38.351 | 1.0001 - 1.5100 | hardened steel | 5000:1 | 38 | Federal |
| 2093041 | DR20-3 | 38.354 - 44.450 | 1.5101 - 1.7500 | hardened steel | 5000:1 | 38 | Federal |
| 2093042 | DR20-3 | 44.453 - 50.797 | 1.75001 - 2.0000 | hardened steel | 5000:1 | 38 | Federal |
| 2093043 | DR20-3 | 50.800 - 63.500 | 2.0001 - 2.5000 | hardened steel | 5000:1 | 38 | Federal |

| Order no. | B | | D | | Nominal size | |
|-----------|-------|-------|--------|--------|------------------|-----------------|
| | mm | mm | mm | mm | inch | mm |
| 2093015 | 25.40 | 76.2 | 6.299 | 7.592 | .2480 - .3000 | 6.299 - 7.592 |
| 2093016 | 25.40 | 76.2 | 7.595 | 9.294 | .3001 - .3650 | 7.595 - 9.294 |
| 2093017 | 25.40 | 76.2 | 9.296 | 13.002 | .3651 - .5100 | 9.296 - 13.002 |
| 2093018 | 25.40 | 76.2 | 13.005 | 21.003 | .5101 - .8250 | 13.005 - 21.003 |
| 2093019 | 25.40 | 76.2 | 21.006 | 25.400 | .8251 - 1.0000 | 21.006 - 25.400 |
| 2093020 | 25.40 | 101.6 | 25.403 | 38.351 | 1.0001 - 1.5100 | 25.403 - 38.351 |
| 2093021 | 25.40 | 101.6 | 38.354 | 44.450 | 1.5101 - 1.7500 | 38.354 - 44.450 |
| 2093022 | 25.40 | 127 | 44.453 | 50.797 | 1.75001 - 2.0000 | 44.453 - 50.797 |
| 2093023 | 25.40 | 127 | 50.800 | 63.500 | 2.0001 - 2.5000 | 50.800 - 63.500 |
| 2093035 | 25.40 | 76.2 | 6.299 | 7.592 | .2480 - .3000 | 6.299 - 7.592 |
| 2093036 | 25.40 | 76.2 | 7.595 | 9.294 | .3001 - .3650 | 7.595 - 9.294 |
| 2093037 | 25.40 | 76.2 | 9.296 | 13.002 | .3651 - .5100 | 9.296 - 13.002 |
| 2093038 | 25.40 | 76.2 | 13.005 | 21.003 | .5101 - .8250 | 13.005 - 21.003 |
| 2093039 | 25.40 | 76.2 | 21.006 | 25.400 | .8251 - 1.0000 | 21.006 - 25.400 |
| 2093040 | 25.40 | 101.6 | 25.403 | 38.351 | 1.0001 - 1.5100 | 25.403 - 38.351 |
| 2093041 | 25.40 | 101.6 | 38.354 | 44.450 | 1.5101 - 1.7500 | 38.354 - 44.450 |
| 2093042 | 25.40 | 127 | 44.453 | 50.797 | 1.75001 - 2.0000 | 44.453 - 50.797 |
| 2093043 | 25.40 | 127 | 50.800 | 63.500 | 2.0001 - 2.5000 | 50.800 - 63.500 |

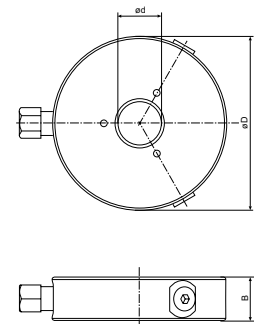

ACCESSORIES

| Order no. | Description | Connection thread |
|-----------|------------------------------------|-------------------|
| 2237666 | Standard plastic handle | 3/8"-32 |
| 2239307 | Universal bench mount | 3/8"-32 |
| 2240993 | Shut off slide valve | 3/8"-32 |
| 2260835 | Connecting hose set, complete, 2 m | 3/8"-32 |



Millimar AAT-19 / AAT-20

Single jet probe

FEATURES

- Jet probes provide convenient modular gageheads for use in handheld gages and for designing gage fixtures
- 9.5 mm / .375" bodies provide standardized mounting configurations
- Compact size allows easy access to hard-to-reach dimensions
- Jet probes are calibrated for instant use with Dimensionair® systems - just set zero and measure!
- Available in single-probe and matched-probe configurations
- Jet probes are similar to air probes, except they have an open jet at the end instead of a contacting spindle
- Ideal for measuring flatness of surfaces which cannot be touched, or for building into fixture designs where air gaging is called for
- Can be used with 2500:1, 5000:1 Dimensionair® (supplied singly or in matched pairs)
- Supplied with AHO-1 air hose, a zero setting valve, and hardware for mounting to the Dimensionair



TECHNICAL DATA

| Order no. | 2086612 | 2086613 |
|---------------|------------------|------------------------|
| Type | AAT-19 | AAT-20 |
| Magnification | 2500:1 | |
| Design | Single jet probe | Matched jet probe pair |

Millimar 6105 N

Master setting rings

FEATURES

- Meticulously hardened, aged, ground and lapped
- Manufacturing tolerance JS3
- Uncertainty of the labeled actual size: 0.5 x IT1
- Setting of pneumatic measuring instruments (nozzle plug gages)
- **Order information:** It is recommended you use the average tolerance of the specified workpiece tolerance as the nominal diameter of the master setting ring



TECHNICAL DATA

| Order no. | Ø | Cylindricity tolerance |
|-----------|--------------|------------------------|
| 2105300 | 2 -3 | 0.1 x IT4 |
| 2105301 | 3.001 -4 | 0.1 x IT4 |
| 2105302 | 4.001 -6 | 0.1 x IT4 |
| 2105303 | 6.001 -7 | 0.1 x IT4 |
| 2105304 | 7.001 -10 | 0.1 x IT4 |
| 2105305 | 10.001 -11 | 0.1 x IT4 |
| 2105306 | 11.001 -18 | 0.1 x IT4 |
| 2105307 | 18.001 -21 | 0.1 x IT4 |
| 2105308 | 21.001 -28 | 0.1 x IT4 |
| 2105309 | 28.001 -32 | 0.1 x IT4 |
| 2105310 | 32.001 -40 | 0.1 x IT4 |
| 2105311 | 40.001 -47 | 0.1 x IT4 |
| 2105312 | 47.001 -50 | 0.1 x IT4 |
| 2105313 | 50.001 -55 | 0.1 x IT4 |
| 2105314 | 55.001 -58 | 0.1 x IT4 |
| 2105315 | 58.001 -60 | 0.1 x IT4 |
| 2105316 | 60.001 -65 | 0.1 x IT4 |
| 2105317 | 65.001 -68 | 0.1 x IT4 |
| 2105318 | 68.001 -70 | 0.1 x IT4 |
| 2105319 | 70.001 -72 | 0.1 x IT4 |
| 2105320 | 72.001 -75 | 0.1 x IT4 |
| 2105321 | 75.001 -78 | 0.1 x IT4 |
| 2105322 | 78.001 -80 | 0.1 x IT4 |
| 2105323 | 80.001 -82 | 0.1 x IT4 |
| 2105324 | 82.001 -85 | 0.1 x IT4 |
| 2105325 | 85.001 -88 | 0.1 x IT4 |
| 2105326 | 88.001 -90 | 0.1 x IT4 |
| 2105327 | 90.001 -92 | 0.1 x IT4 |
| 2105328 | 92.001 -95 | 0.1 x IT4 |
| 2105329 | 95.001 -98 | 0.1 x IT4 |
| 2105330 | 98.001 -100 | 0.1 x IT4 |
| 2105331 | 100.001 -105 | 0.1 x IT4 |
| 2105332 | 105.001 -110 | 0.1 x IT4 |
| 2105333 | 110.001 -115 | 0.1 x IT4 |
| 2105334 | 115.001 -120 | 0.1 x IT4 |
| 2105335 | 120.001 -125 | 0.1 x IT4 |
| 2105336 | 125.001 -130 | 0.1 x IT4 |
| 2105337 | 130.001 -135 | 0.1 x IT4 |
| 2105338 | 135.001 -140 | 0.1 x IT4 |
| 2105339 | 140.001 -145 | 0.1 x IT4 |
| 2105340 | 145.001 -150 | 0.1 x IT4 |
| 2105341 | 150.001 -155 | 0.1 x IT4 |
| 2105342 | 155.001 -160 | 0.1 x IT4 |
| 2105343 | 160.001 -165 | 0.1 x IT4 |
| 2105344 | 165.001 -170 | 0.1 x IT4 |
| 2105345 | 170.001 -175 | 0.1 x IT4 |
| 2105346 | 175.001 -180 | 0.1 x IT4 |
| 2105347 | 180.001 -185 | 0.1 x IT4 |

Millimar 6107 S

Master setting rings

FEATURES

- Meticulously hardened, aged, ground and lapped
- Manufacturing tolerance JS3
- Uncertainty of the labeled actual size: 0.5 x IT1
- Setting of pneumatic measuring instruments (nozzle plug gages)
- **Order information:** It is recommended you use the average tolerance of the specified workpiece tolerance as the nominal diameter of the master setting ring



TECHNICAL DATA

| Order no. | Ø | Cylindricity tolerance |
|-----------|--------------|------------------------|
| 2105400 | 3 -4 | 0.1 x IT3 |
| 2105401 | 4.001 -6 | 0.1 x IT3 |
| 2105402 | 6.001 -8 | 0.1 x IT3 |
| 2105403 | 8.001 -10 | 0.1 x IT3 |
| 2105404 | 10.001 -18 | 0.1 x IT3 |
| 2105405 | 18.001 -23 | 0.1 x IT3 |
| 2105406 | 23.001 -24 | 0.1 x IT3 |
| 2105407 | 24.001 -25 | 0.1 x IT3 |
| 2105408 | 25.001 -26 | 0.1 x IT3 |
| 2105409 | 26.001 -27 | 0.1 x IT3 |
| 2105410 | 27.001 -28 | 0.1 x IT3 |
| 2105411 | 28.001 -30 | 0.1 x IT3 |
| 2105412 | 30.001 -32 | 0.1 x IT3 |
| 2105413 | 32.001 -34 | 0.1 x IT3 |
| 2105414 | 34.001 -37 | 0.1 x IT3 |
| 2105415 | 37.001 -42 | 0.1 x IT3 |
| 2105416 | 42.001 -44 | 0.1 x IT3 |
| 2105417 | 44.001 -45 | 0.1 x IT3 |
| 2105418 | 45.001 -46 | 0.1 x IT3 |
| 2105419 | 46.001 -48 | 0.1 x IT3 |
| 2105420 | 48.001 -50 | 0.1 x IT3 |
| 2105421 | 50.001 -52 | 0.1 x IT3 |
| 2105422 | 52.001 -55 | 0.1 x IT3 |
| 2105423 | 55.001 -58 | 0.1 x IT3 |
| 2105424 | 58.001 -60 | 0.1 x IT3 |
| 2105425 | 60.001 -62 | 0.1 x IT3 |
| 2105426 | 62.001 -65 | 0.1 x IT3 |
| 2105427 | 65.001 -68 | 0.1 x IT3 |
| 2105428 | 68.001 -70 | 0.1 x IT3 |
| 2105429 | 70.001 -72 | 0.1 x IT3 |
| 2105430 | 72.001 -75 | 0.1 x IT3 |
| 2105431 | 75.001 -78 | 0.1 x IT3 |
| 2105432 | 78.001 -80 | 0.1 x IT3 |
| 2105433 | 80.001 -82 | 0.1 x IT3 |
| 2105434 | 82.001 -85 | 0.1 x IT3 |
| 2105435 | 85.001 -88 | 0.1 x IT3 |
| 2105436 | 88.001 -90 | 0.1 x IT3 |
| 2105437 | 90.001 -92 | 0.1 x IT3 |
| 2105438 | 92.001 -95 | 0.1 x IT3 |
| 2105439 | 95.001 -98 | 0.1 x IT3 |
| 2105440 | 98.001 -100 | 0.1 x IT3 |
| 2105441 | 100.001 -102 | 0.1 x IT3 |

Millimar 6400

Master setting plugs

FEATURES

- Meticulously hardened, aged, ground and lapped
- Manufacturing tolerance JS3
- Uncertainty of the labeled actual size: 0.5 x IT1
- Setting of pneumatic measuring instruments (nozzle ring gages)
- **Order information:** It is recommended you use the average tolerance of the specified workpiece tolerance as the nominal diameter of the master setting ring



TECHNICAL DATA

| Order no. | ∅ | Cylindricity tolerance |
|-----------|-------------|------------------------|
| 5264001 | 6.001 –12 | 0.1 x IT3 |
| 5264002 | 12.001 –18 | 0.1 x IT3 |
| 5264003 | 18.001 –24 | 0.1 x IT3 |
| 5264004 | 24.001 –30 | 0.1 x IT3 |
| 5264005 | 30.001 –35 | 0.1 x IT3 |
| 5264006 | 35.001 –40 | 0.1 x IT3 |
| 5264007 | 40.001 –45 | 0.1 x IT3 |
| 5264008 | 45.001 –50 | 0.1 x IT3 |
| 5264009 | 50.001 –55 | 0.1 x IT3 |
| 5264010 | 55.001 –60 | 0.1 x IT3 |
| 5264011 | 60.001 –65 | 0.1 x IT3 |
| 5264012 | 65.001 –70 | 0.1 x IT3 |
| 5264013 | 70.001 –75 | 0.1 x IT3 |
| 5264014 | 75.001 –80 | 0.1 x IT3 |
| 5264015 | 80.001 –85 | 0.1 x IT3 |
| 5264016 | 85.001 –90 | 0.1 x IT3 |
| 5264017 | 90.001 –95 | 0.1 x IT3 |
| 5264018 | 95.001 –100 | 0.1 x IT3 |
| 5264020 | 2 –3 | 0.1 x IT3 |
| 5264021 | 3.001 –4 | 0.1 x IT3 |
| 5264022 | 4.001 –6 | 0.1 x IT3 |

Millimar | Standard elements

Modular

The use of Millimar standard elements allows multi-gage measuring devices to be designed and implemented for the widest possible range of workpieces, e.g. rotationally symmetrical and non-rotationally symmetrical parts.

Rotationally symmetrical workpieces can be mounted between centers or on prismatic supports, whereas non-rotationally symmetrical workpieces often require a special holder.

Versatile

The versatility of the Millimar standard elements means that the right solution can be provided, regardless of the measurement task at hand.

Whether it's a question of external, internal or length measurements, the Millimar standard elements will be able to meet your requirements, even in the case of complex workpiece geometries.

Thanks to the space saving design of the styli, a high number of measuring points can be inspected within a small area of the testpiece.

The pneumatic lifting mechanisms integrated into the measuring elements simplify the job of moving the testpiece into the measuring position and reduce the amount of wear on the stylus.

Flexible

The modular concept using Millimar standard elements is continued throughout the construction of the whole system. A generous amount of travel in the stylus (up to 20 mm / 0.79") allows a high degree of flexibility in terms of the variety of testpieces that can be accommodated.

Precise

The Millimar standard elements are specially designed for use in the workshop and are manufactured using a rigorous process. This guarantees that the measuring devices give stable and reliable measurements.

For example, using styli fitted with two ball-bearing guides for supporting the moving part, it is possible to achieve measurement accuracy at the μm scale, if this is required due to the tolerances of the feature being measured.

Reliable

All components are long lasting and low maintenance thanks to the use of rust proof materials, the selection of appropriate heat treatments, and the use of a lifting mechanism to minimize the effects of friction acting on the styli when the workpiece is inserted.

Economical

Our systems can either be constructed by the customer from standard elements obtained from the catalog, or alternatively we can provide ready-built devices as turn-key solutions. Whichever option you choose, you can be sure that you are purchasing a system that is tailored to your specific requirements on the most favorable of terms.

Below are just a few examples of the many factors that contribute to the cost effectiveness of the Millimar standard elements:

- Reusability of standard elements: Once manufacture of a particular type of workpiece has ceased, all standard elements used in the test equipment can be reused for a different type of workpiece.
- A choice of different mechanisms for guiding the moving part of the stylus, according to the accuracy requirements of the measuring task (optimal price-performance ratio).
- Reduction in development and implementation time.
- Availability of the equipment: Our standard elements are manufactured under standard production conditions and are always available off the shelf and ready to use.



Detailed information can be found in the catalog –
Components for Length Metrology

Millimar | Standard elements

Gage module

Travel distance: 5 - 10 - 20 mm

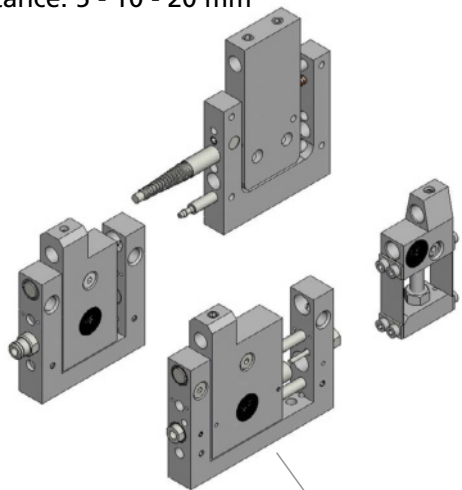

XY tables

Travel distance: 2.5 - 5 - 7 mm

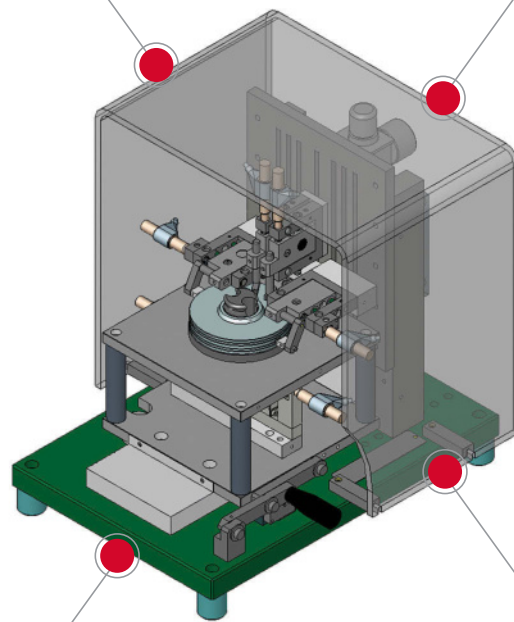
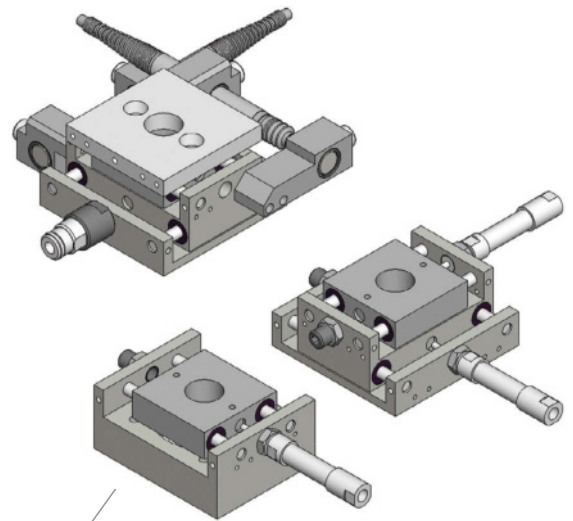

Angular adjustment
0 - 30 - 45 - 60 - 90°

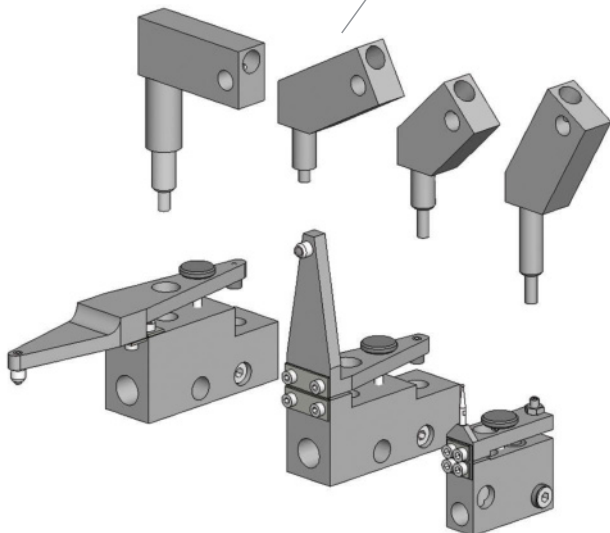

Styli

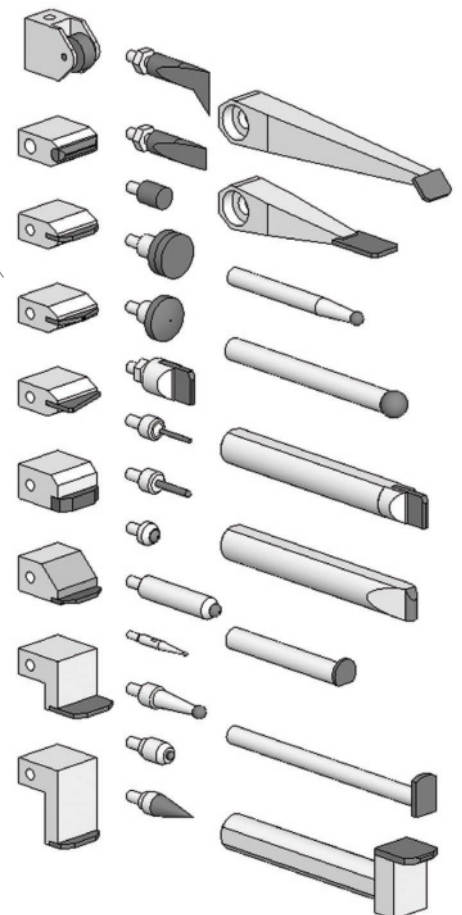

MarStand | Measuring tables, measuring tripods, radial runout gages

MarStand measuring stands, measuring tables and radial runout gages offer high stability, the basis for precise measuring results. They offer the necessary support for your dial indicators, dial comparators, dial test indicator measuring devices and measuring probes.



Measuring stands

MarStand 815 GN 270
Measuring stand with triangular pedestal

MarStand 815 MA / 815 MB / 815 P / 815 MG / 815 MF 271
Measuring tripod with magnetic base

Indicator stand

MarStand 815 XMA / 815 XMB / 815 XMS / 815 XN / 815 XP 276
With screw-in thread and/or t-slot nut

Measuring tables

MarStand 820 N 277
Small steel measuring table

MarStand 820 NC / 820 FC 278
Small ceramic measuring table

MarStand 820 NG / 820 FG 279
Small measuring table, granite measuring plate

MarStand 821 NG / 821 FG 280
Large granite measuring table

MarStand 824 FT / 824 GT 281
Heavy measuring table

Measuring table systems

MarStand 827 282
Heavy measuring table in the modular unit

Test plates

MarStand 107 G 284
Granite test plate

Radial runout gages

MarStand 818 287
Radial runout gage with center supports

MarStand 818 P 288
Radial runout gage with vee supports

MarStand 818 R 289
Radial runout gage with balancing supports

MarStand 815 GN

Measuring tripod with triangular pedestal

FEATURES

- Sturdy base for stability and strength
- Convenient hand grip at the top of the base
- Structurally stable three-point support
- Stainless steel column and support arm
- Fine adjustment at support arm
- Display unit can be swiveled by $\pm 90^\circ$
- Easy to move without vibration
- Front of the base is ground to allow movement along edges and rulers
- Package excludes indicator



Application:

- For use on measuring and control plates

TECHNICAL DATA

| Order no. | | 4413000 | 4413001 | 4413005 | 4413050 | 4413051 | 4413052 |
|----------------------------|------|---------|---------|---------|---------|---------|---------|
| Type | | 815 GN | | | | | |
| Precision adjustment range | mm | 2 | | | | | |
| Total height | mm | 300 | 500 | 750 | 300 | 500 | 750 |
| Total height | inch | 12" | 20" | 30" | 12" | 20" | 30" |
| Projection (max.) | mm | 185 | 200 | 230 | 185 | 200 | 230 |
| Projection (max.) | inch | 7.28" | 7.87" | 9.06" | 7.28" | 7.87" | 9.06" |
| Mounting hole | | 8H7 | | | .375" | | |
| Product weight | kg | 4.20 | 9.00 | 10.00 | 4.20 | 9.00 | 10.00 |

| Order no. | Base surface | a | b | c | d |
|-----------|--------------|-----|-----|----|----|
| | | mm | mm | mm | mm |
| 4413000 | 150 x 150 mm | 300 | 185 | 18 | 14 |
| 4413001 | 190 x 180 mm | 500 | 200 | 25 | 18 |
| 4413005 | 190 x 180 mm | 750 | 230 | 35 | 25 |
| 4413050 | 150 x 150 mm | 300 | 185 | 18 | 14 |
| 4413051 | 190 x 180 mm | 500 | 200 | 25 | 18 |
| 4413052 | 190 x 180 mm | 750 | 230 | 35 | 25 |

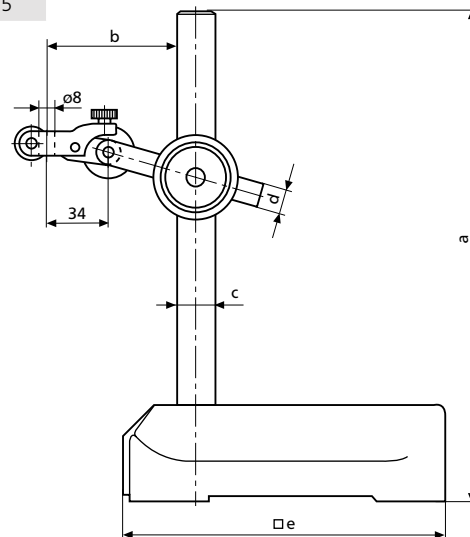

MarStand 815 MA

Measuring tripod with magnetic base

FEATURES

- Support arm with two joints
- Base has a powerful ON/OFF permanent magnet
- Magnetic force is active across:
 - Surfaces
 - V-shaped bottom
 - Front of base
- Post and support arm are made of stainless steel
- Support arm can be finely adjusted
- Package excludes indicator



TECHNICAL DATA

| Order no. | | 4416000 | 4416050 |
|----------------------------|------|---------|----------|
| Type | | | 815 MA |
| Precision adjustment range | mm | | 2 |
| Total height | mm | | 285 |
| Total height | inch | | 11.2" |
| Projection (max.) | mm | | 230 |
| Projection (max.) | inch | | 9.06" |
| Mounting hole | | 8H7 | .375" |
| V-block for shaft diameter | mm | | 20 – 100 |
| Adhesive force prism | N | | 450 |
| Product weight | kg | | 2.50 |

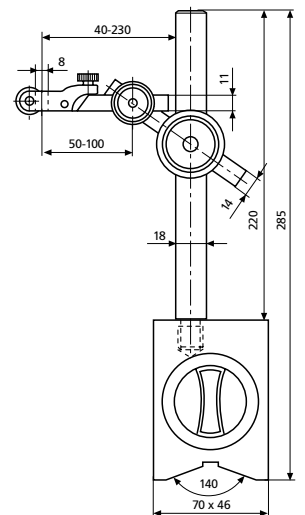

ACCESSORIES

| Order no. | Description |
|-----------|-------------|
| 4416001 | Wooden case |

MarStand 815 MB

Measuring tripod with magnetic base

FEATURES

- Support arm with one joint
- Base has a powerful ON/OFF permanent magnet
- Magnetic force is active across:
 - Surfaces
 - V-shaped bottom
 - Front of base
- Post and support arm are made of stainless steel
- Support arm can be finely adjusted
- Indicating instrument can be rotated through $\pm 90^\circ$
- Package excludes indicator



TECHNICAL DATA

| Order no. | | 4417000 | 4417050 |
|----------------------------|------|---------|----------|
| Type | | | 815 MB |
| Precision adjustment range | mm | | 2 |
| Total height | mm | | 285 |
| Total height | inch | | 11.2" |
| Projection (max.) | mm | | 190 |
| Projection (max.) | inch | | 7.48" |
| Mounting hole | | 8H7 | .375" |
| V-block for shaft diameter | mm | | 20 – 100 |
| Adhesive force prism | N | | 450 |
| Product weight | kg | | 2.20 |

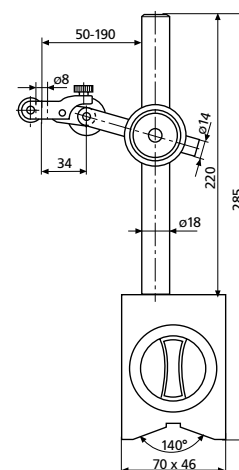

ACCESSORIES

| Order no. | Description |
|-----------|-------------|
| 4416001 | Wooden case |

MarStand 815 P

Measuring tripod with magnetic base

FEATURES

- Support arm has one joint
- Sturdy circular base with permanent magnet
- Post and support arm are made of stainless steel
- Support arm can be finely adjusted
- Indicating instrument can be rotated through $\pm 90^\circ$
- Package excludes indicator



TECHNICAL DATA

| Order no. | | 4422000 | 4422050 |
|----------------------------|------|---------|---------|
| Type | | | 815 P |
| Precision adjustment range | mm | | 1.5 |
| Total height | mm | | 205 |
| Total height | inch | | 8" |
| Projection (max.) | mm | | 130 |
| Projection (max.) | inch | | 5.12" |
| Mounting hole | | 8H7 | .375" |
| Product weight | kg | | 0.70 |

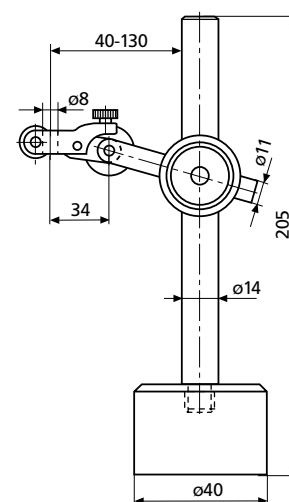

MarStand 815 MG

Measuring tripod with magnetic base

FEATURES

- 3D jointed arm, can reach any position within the operating range
- Easy positioning of all three joints with a securely fixed handle
- Maintenance-free mechanical clamping system
- Black anodized arm components made from high quality light alloy
- Dial indicator holder with 8 mm mounting bore and dovetail for dial test indicator measuring devices
- Fitted with zero-play micro-precision adjuster
- Very powerful switching magnet
- Package excludes indicator



TECHNICAL DATA

| Order no. | | 4420350 | 4420360 | 4420370 |
|----------------------------|------|---------|---------|---------|
| Type | | | 815 MG | |
| Precision adjustment range | mm | 5 | | |
| Total height | mm | 222 | 310 | 390 |
| Total height | inch | 8.74 | 12.2 | 15.35 |
| Projection (max.) | mm | 130 | 200 | 280 |
| Projection (max.) | inch | 5.12 | 7.87 | 11.02 |
| Mounting hole | | 8H7 | | |
| V-block for shaft diameter | mm | 6–120 | | |
| Adhesive force prism | N | 300 | 800 | |

| Order no. | Base surface | j | k | l | a | b | d |
|-----------|-----------------|-----|-----|----|-----|-----|----|
| | | mm | mm | mm | mm | mm | mm |
| 4420350 | 36 x 30 x 35 mm | 70 | 60 | 49 | 222 | 130 | 8 |
| 4420360 | 60 x 50 x 55 mm | 120 | 80 | 49 | 310 | 200 | 8 |
| 4420370 | 60 x 50 x 55 mm | 170 | 110 | 49 | 390 | 280 | 8 |

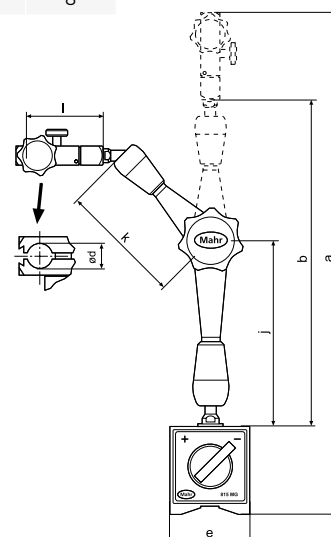

MarStand 815 MF

Measuring tripod with magnetic base

FEATURES

- 3D jointed arm, can reach any position within the operating range
- Easy positioning of all three joints with a securely fixed handle
- Very sturdy components, for excellent stability and accuracy
- Maintenance-free mechanical clamping system
- Black anodized arm components made from high quality light alloy
- Dial indicator holder with 8 mm mounting bore and dovetail for dial test indicator measuring devices
- Fitted with zero-play micro-precision adjuster
- Very easy to adjust, excellent repeatability
- Ideal for measuring instruments with μm resolution
- Very powerful switching magnet
- Package excludes indicator

Application:

- Special made for indicators and comparators with μm resolution

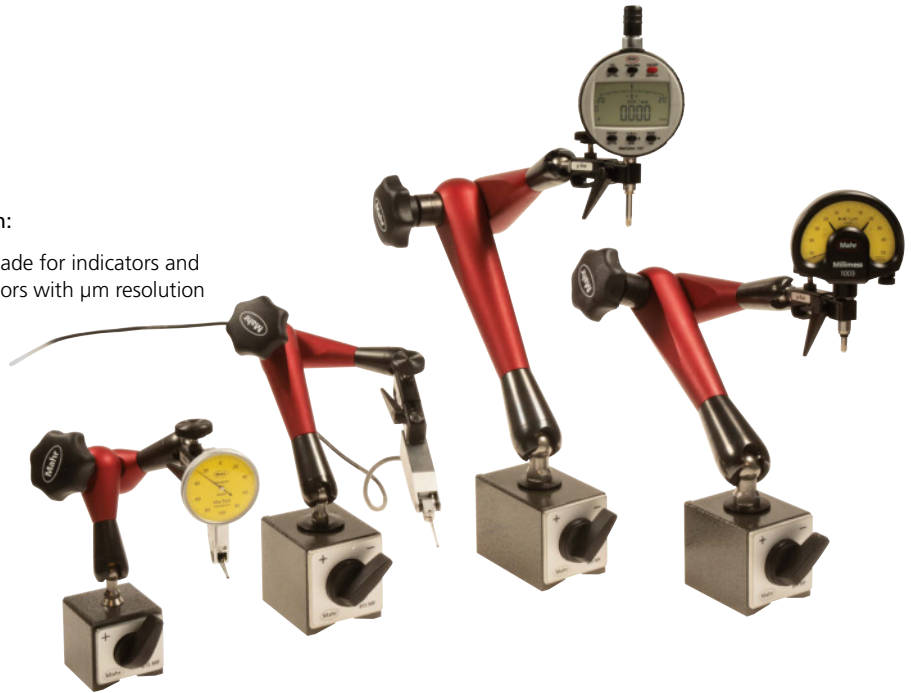

TECHNICAL DATA

| Order no. | | 4420385 | 4420386 | 4420387 | 4420388 |
|----------------------------|------|---------|---------|---------|---------|
| Type | | 815 MF | | | |
| Precision adjustment range | mm | 2 | | | |
| Total height | mm | 228 | 317 | 399 | 444 |
| Total height | inch | 8.97 | 12.48 | 15.70 | 17.48 |
| Projection (max.) | mm | 130 | 204 | 287 | 330 |
| Projection (max.) | inch | 5.12 | 8.03 | 11.3 | 12.99 |
| Mounting hole | | 8H7 | | | |
| V-block for shaft diameter | mm | 6 – 120 | | | |
| Adhesive force prism | N | 300 | 800 | | 1000 |

| Order no. | Base surface | j | k | l | a | b | d |
|-----------|-----------------|-----|-----|----|-----|-----|----|
| | | mm | mm | mm | mm | mm | mm |
| 4420385 | 40 x 40 x 40 mm | 71 | 59 | 49 | 228 | 130 | 8 |
| 4420386 | 60 x 50 x 55 mm | 116 | 88 | 49 | 317 | 204 | 8 |
| 4420387 | 60 x 50 x 55 mm | 172 | 115 | 49 | 399 | 287 | 8 |
| 4420388 | 73 x 50 x 55 mm | 201 | 129 | 49 | 444 | 330 | 8 |

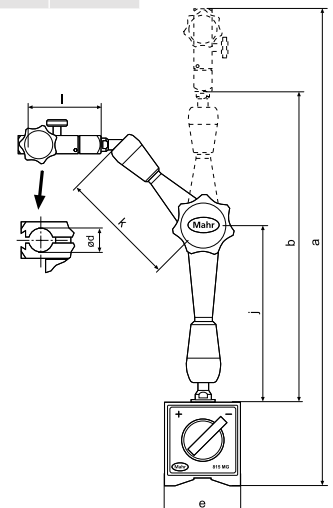

MarStand

Post and support assemblies

OVERVIEW

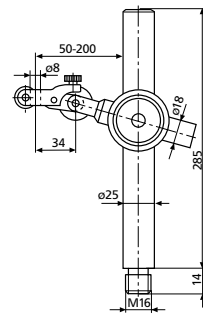
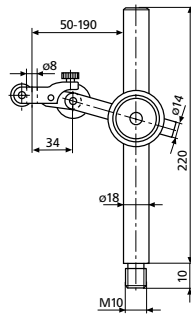
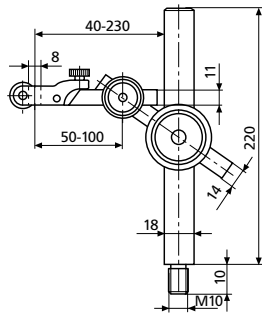

| Type | 815 XMA | 815 XMB | 815 XMS 285 |
|------------------|--|---|---|
| Order no. | 4424005 | 4424006 | 4435011 |
| Product features | <ul style="list-style-type: none"> Sturdy design with mounting thread Two joints Post and support arm are made of stainless steel With fine adjustment | <ul style="list-style-type: none"> Sturdy design with mounting thread One joint Post and support arm are made of stainless steel With fine adjustment | <ul style="list-style-type: none"> Sturdy design with mounting thread One joint Post and support arm are made of stainless steel With fine adjustment |

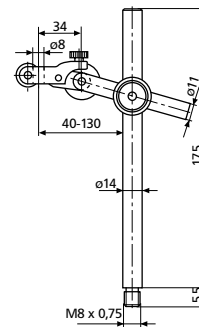
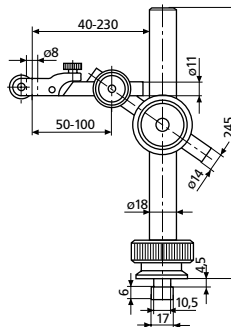
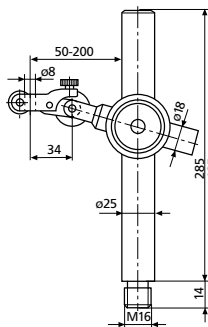

| Type | 815 XMS 485 | 815 XN | 815 XP |
|------------------|---|--|---|
| Order no. | 4435015 | 4424000 | 4424015 |
| Product features | <ul style="list-style-type: none"> Exceptionally sturdy design with screw-in thread One joint Stainless steel column and cantilever arms Precision adjuster | <ul style="list-style-type: none"> Sturdy design for mounting in a T-slot Two joints Knurled nut for clamping Post and support arm are made of stainless steel With fine adjustment | <ul style="list-style-type: none"> Sturdy design with mounting thread One joint Post and support arm are made of stainless steel With fine adjustment |

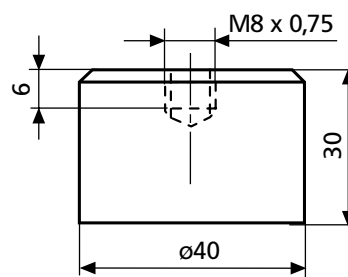
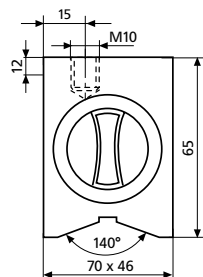

| Type | 815 YM | 815 YP |
|------------------|---|--|
| Order no. | 4425000 | 4425002 |
| Product features | Standard model <ul style="list-style-type: none"> Powerful permanent magnet can be switched on and off Screw-in thread Bottom with V-groove End face is flat Magnetic force 450N | Round version <ul style="list-style-type: none"> Permanent magnet plus threaded mounting hole Underside of the base is flat Magnetic force 250N |

MarStand 820 N

Small steel comparator stand

FEATURES

- Stable design
- Table plate made of hardened steel
- Rugged, ground stainless steel column
- Adjustable support arm for indicating instrument
- Package excludes indicator



TECHNICAL DATA

| Order no. | | 4430000 | 4430018 |
|--------------------|------|--|------------|
| Type | | | 820 N |
| Working range a | mm | | 0 – 110 |
| Working range a | inch | | 0 – 4.3" |
| Grade | | | DIN 876/00 |
| Flatness tolerance | | $t_1 = 2 (1 + L/1000) \mu\text{m}$, L in mm | |
| Mounting hole | | 8H7 | 3/8" |
| Product weight | kg | | 2.60 |

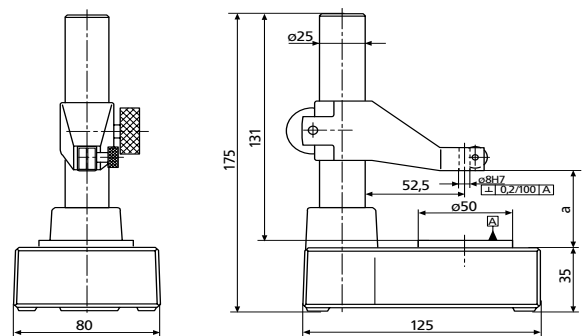

MarStand 820 NC / 820 FC

Small ceramic comparator stand

FEATURES

- Stable design
- Ceramic table plate (high hardness for lasting precision)
- Rugged, ground stainless steel column
- Adjustable support arm for indicating instrument
- Package excludes indicator



TECHNICAL DATA

| Order no. | | 4432100 | 4432120 | 4433100 | 4433110 |
|----------------------------|------|--|---------|---------|---------|
| Type | | 820 NC | | 820 FC | |
| Working range a | mm | 0 – 110 | | | |
| Working range a | inch | 0 – 4.3" | | | |
| Precision adjustment range | mm | | | 0,4 | |
| Grade | | DIN 876/00 | | | |
| Flatness tolerance | | $t_f = 2 (1 + L/1000) \mu\text{m}$, L in mm | | | |
| Mounting hole | | 8H7 | 3/8" | 8H7 | 3/8" |
| Product weight | kg | 4.00 | | | |

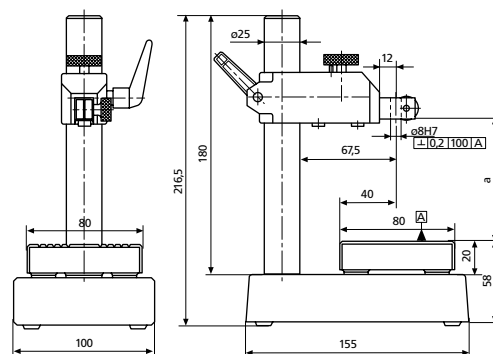

MarStand 820 NG / 820 FG

Small comparator stand, plate made of granite

FEATURES

- Stable design
- Table plate made of lapped black granite
- Rugged, ground stainless steel column
- Adjustable support arm for indicating instrument
- Package excludes indicator



TECHNICAL DATA

| Order no. | | 4430100 | 4430110 | 4431100 | 4431110 |
|----------------------------|------|--|---------|---------|---------|
| Type | | 820 NG | | 820 FG | |
| Working range a | mm | 0 – 130 | | | |
| Working range a | inch | 0 – 5.1" | | | |
| Precision adjustment range | mm | | | 0,4 | |
| Grade | | DIN 876/0 | | | |
| Flatness tolerance | | $t_1 = 4 (1 + L/1000) \mu\text{m}$, L in mm | | | |
| Mounting hole | | 8H7 | 3/8" | 8H7 | 3/8" |
| Product weight | kg | 3.20 | | | |

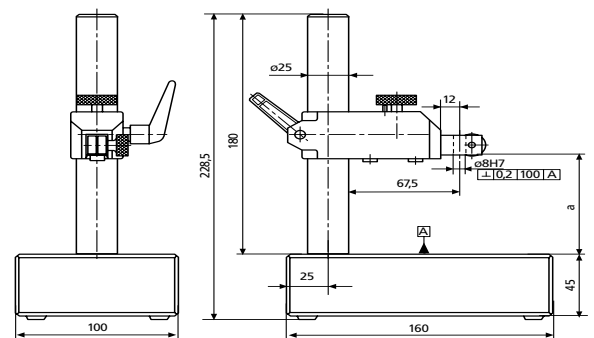

MarStand 821 NG / 821 FG

Large granite comparator stand

FEATURES

- Exceptionally stable design
- Table plate made of lapped black granite
- Heavy duty column and adjustable support arm for maximum stability
- Made of ground stainless steel
- Support arm fitted with fall brake
- Package excludes indicator



TECHNICAL DATA

| Order no. | 4435100 | 4435101 | 4435110 | 4435111 | 4435150 | 4435151 | 4435160 | 4435161 |
|----------------------------|---------|---|---------|---------|---------|---------|---------|---------|
| Type | 821 NG | 821 FG | 821 NG | 821 FG | 821 NG | 821 FG | 821 NG | 821 FG |
| Working range a | mm | 0–250 | | 0–430 | | 0–250 | | 0–430 |
| Working range a | inch | 0–10" | | 0–17" | | 0–10" | | 0–17" |
| Precision adjustment range | mm | | 0.4 | | 0.4 | | 0.4 | |
| Grade | | DIN 876/0 | | | | | | |
| Flatness tolerance | | $t_1 = 4(1 + L/1000) \mu\text{m}$. L in mm | | | | | | |
| Mounting hole | | 8H7 | | | 3/8" | | | |
| Product weight | kg | 15.80 | | 48.00 | | 15.80 | | 48.00 |

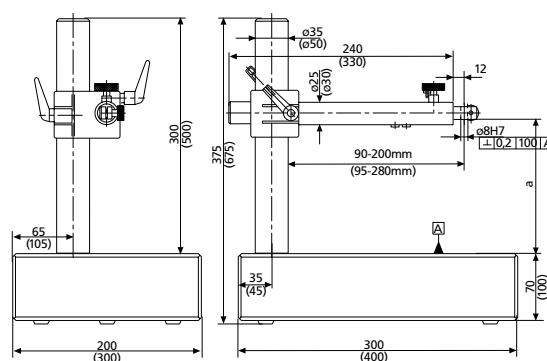

MarStand 824 FT / 824 GT

Heavy measuring table

FEATURES

- Sturdy, T-shaped base made from special cast iron
- Extremely stable
- Heavy duty column and support arm for maximum stability
- Support arm locked against rotation and height adjustable via rack
- **Models:**
 - 824 NT - without fine adjustment
 - 824 FT - with fine adjustment via parallel spring-loaded system
 - 824 GT - specially designed for the large Millimess dial comparator, with fine adjustment via the adapter bushing
- Package excludes indicator and plate



TECHNICAL DATA

| Order no. | | 4443100 | 4443105 | 4444200 |
|----------------------------|------|----------|---------|----------|
| Type | | 824 FT | | 824 GT |
| Working range a | mm | 0 – 210 | | 0 – 200 |
| Working range a | inch | 0 – 8.2" | | 0 – 8.0" |
| Precision adjustment range | mm | 0.4 | | 3 |
| Mounting hole | | 8H7 | 3/8" | 28H7 |
| Product weight | kg | 19.00 | | 18.00 |

ACCESSORIES

| Order no. | Description | Type |
|-----------|--|-----------------|
| 4082731 | Plate for single measurement (100 x 40 mm) | 827 b 31 |
| 4082732 | Plate for sum measurement (100 x 40 mm) | 827 b 32 |
| 4082733 | Plate for single measurement (130 x 130 mm) | 827 b 33 |
| 4082734 | Plate for sum measurement (130 x 130 mm) | 827 b 34 |
| 4346111 | 941 G holder Ø 28mm, length 100mm, range 3 mm (with mount bore for indicators with shaft Ø 8 mm) | 941 G / Ø 28 mm |

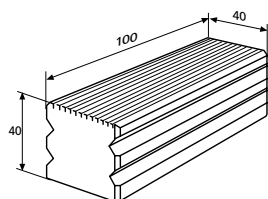

827 b 31

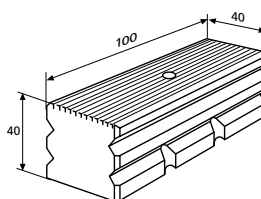

827 b 32

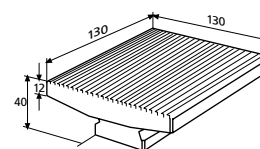

827 b 33

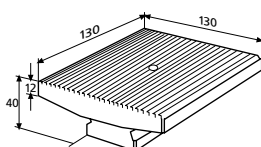

827 b 34



941 G / Ø 28 mm

MarStand

Base with post

OVERVIEW

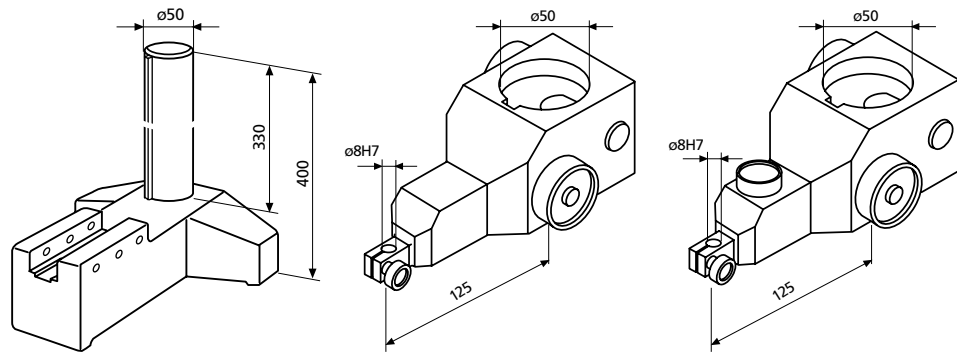

| Type | 827 b 5 | 827 b 16 | 827 b 17 |
|-------------------|---|--|---|
| Order no. | 4082705 | 4082716 | 4082717 |
| Product features | <ul style="list-style-type: none"> Measuring table base with column T-shaped base made from special cast iron Chrome-plated column | <ul style="list-style-type: none"> Support arm without fine adjustment Rugged construction for exceptionally high bending resistance Locked against rotation and height adjustable via rack Mounting hole 8 mm | <ul style="list-style-type: none"> Support arm with fine adjustment Rugged construction for exceptionally high bending resistance Locked against rotation and height adjustable via rack Mounting hole 8 mm |
| Projection (max.) | 125 mm | 125 mm | 125 mm |
| Mounting hole | | 8H7 | 8H7 |

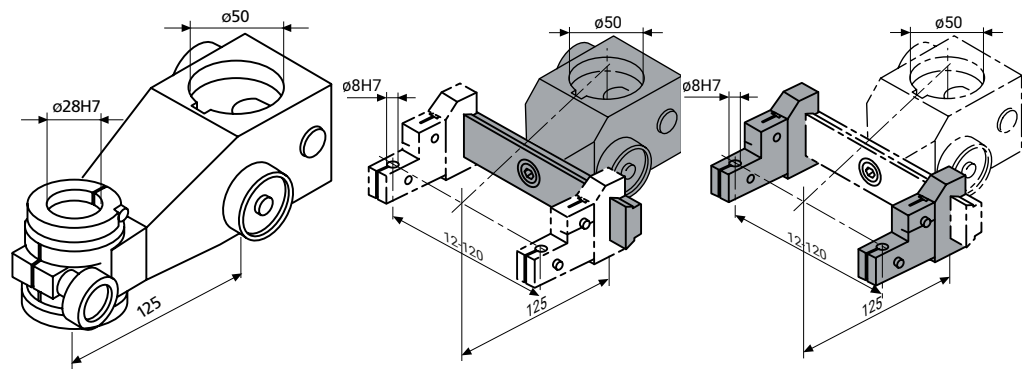

| Type | 827 b 18 | 827 b 19 | 827 b 14 |
|-------------------|--|--|--|
| Order no. | 4082718 | 4082719 | 4082714 |
| Product features | <ul style="list-style-type: none"> Support arm with fine adjustment Rugged construction for exceptionally high bending resistance Locked against rotation and height adjustable via rack Mounting hole for big comparators with stem diameter 28 mm, for example Millimes 1000 A | <ul style="list-style-type: none"> Support arm with dovetail guide Rugged construction for exceptionally high bending resistance Locked against rotation and height adjustable via rack | <ul style="list-style-type: none"> Probe holder For mounting on dovetail guide of support arm 827 b 19 Mounting hole 8 mm |
| Projection (max.) | 125 mm | 125 mm | 125 mm |
| Mounting hole | 28H7 | | 8H7 |

MarStand

Plate for single measurement

OVERVIEW

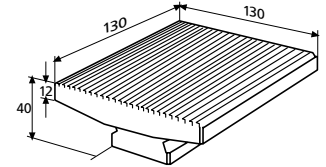
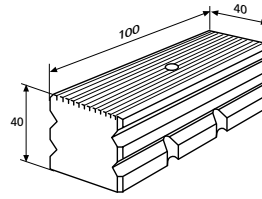
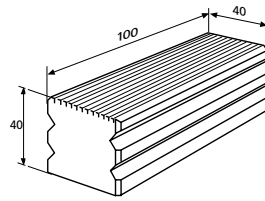

| Type | 827 b 31 | 827 b 32 | 827 b 33 |
|--------------------|--|--|--|
| Order no. | 4082731 | 4082732 | 4082733 |
| Product features | <ul style="list-style-type: none"> • Plate for single measurement • Hardened and lapped • Reversible • One measuring surface with longitudinal ribbing • Both sides face lapped | <ul style="list-style-type: none"> • Plate for compound measurement • Hardened and lapped • With 8 mm mounting bore and clamping device for inductive probes • Measuring surface with longitudinal ribbing | <ul style="list-style-type: none"> • Plate for single measurement • Hardened and lapped • Reversible • Large measuring surface with longitudinal ribbing • Both sides face lapped |
| Sum measurement | | • | |
| Flatness deviation | 1 µm | 1 µm | 1 µm |
| Mounting hole | | 8H7 | |

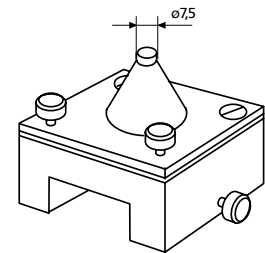
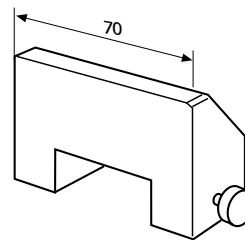
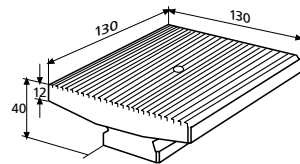

| Type | 827 b 34 | 827 b 35 | 827 b 36 |
|--------------------|--|---|--|
| Order no. | 4082734 | 4082735 | 4082736 |
| Product features | <ul style="list-style-type: none"> • Plate for compound measurement • Hardened and lapped • With 8 mm mounting bore and clamping device for inductive probes • Large measuring surface with longitudinal ribbing | <ul style="list-style-type: none"> • Adjustable stop • Ensures that a workpiece is correctly positioned • To be attached to plates 827 b 31 and 827 b 32 | <ul style="list-style-type: none"> • Attachment stand • With adjustment screws for parallel alignment of 2 plan surfaces • Particularly suitable for mounting pin gages 426 M • To be attached to plates 827 b 31 and 827 b 32 |
| Flatness deviation | 1 µm | | |
| Mounting hole | 8H7 | | |

MarStand 107 G

Surface plate made from granite

FEATURES

- Made of choice fine grain black granite (Diabase)
- High density structure is extremely homogeneous
- Hardness 6–7 on the Mohs hardness scale
- Surface plate is lapped and has a satin matt finish to prevent glare
- 100 % corrosion proof
- Non-magnetic and non-conductive
- Measuring instruments and test equipment easily slide over surface



Applications:

- For measuring tasks, layout work, touching up and lapping precision parts
- Recommended assembly (with optional accessories):
 - Up to 400 mm to be used on a workbench with adjustable plate supports 107 Asa
 - From 630 mm to be used with a stand 107 Us or cabinet 107 Ug

TECHNICAL DATA

| Order no. | 4221500 | 4221501 | 4221502 | 4221503 | 4221504 | 4221505 | 4221506 | 4221507 | 4221508 | | |
|--------------------|---------|--|-----------|-----------|-----------|-----------|------------|------------|-------------|-------------|--|
| Type | 107 G | | | | | | | | | | |
| Plate size | mm | 400 x 250 | 400 x 400 | 630 x 400 | 630 x 630 | 800 x 500 | 1000 x 630 | 1200 x 800 | 1500 x 1000 | 2000 x 1000 | |
| Plate thickness | mm | 60 | | 80 | | 100 | | 150 | | 200 | |
| Standard | | DIN 876 | | | | | | | | | |
| Tolerance class | | 00 | | | | | | | | | |
| Flatness tolerance | | $t_f = 2 (1 + L/1000) \mu\text{m}$, L in mm | | | | | | | | | |
| Weight | kg | 18 | 29 | 60 | 95 | 120 | 190 | 432 | 675 | 1200 | |

ACCESSORIES

| Order no. | Description | Type |
|-----------|---|---------|
| 4221560 | Cabinet underframe with edge protection, 630 x 400 mm | 107 Us |
| 4221570 | Open underframe with edge protection, 630 x 400 mm | 107 Ug |
| 4221069 | Adjustable support element for test plates | 107 Asa |
| 4221561 | Cabinet underframe with edge protection, 630 x 630 mm | 107 Us |
| 4221571 | Open underframe with edge protection, 630 x 630 mm | 107 Ug |
| 4221562 | Cabinet underframe with edge protection, 800 x 500 mm | 107 Us |
| 4221572 | Open underframe with edge protection, 800 x 500 mm | 107 Ug |
| 4221563 | Cabinet underframe with edge protection, 1000 x 630 mm | 107 Us |
| 4221573 | Open underframe with edge protection, 1000 x 630 mm | 107 Ug |
| 4221564 | Cabinet underframe with edge protection, 1200 x 800 mm | 107 Us |
| 4221574 | Open underframe with edge protection, 1200 x 800 mm | 107 Ug |
| 4221565 | Cabinet underframe with edge protection, 1500 x 1000 mm | 107 Us |
| 4221575 | Open underframe with edge protection, 1500 x 1000 mm | 107 Ug |
| 4221566 | Cabinet underframe with edge protection, 2000 x 1000 mm | 107 Us |
| 4221576 | Open underframe with edge protection, 2000 x 1000 mm | 107 Ug |



107G + 107 US



107G + 107 UG

MarStand 107 G

Surface plate made from granite

FEATURES

- Made of choice fine grain black granite (Diabase)
- High density structure is extremely homogeneous
- Hardness 6–7 on the Mohs hardness scale
- Surface plate is lapped and has a satin matt finish to prevent glare
- 100 % corrosion proof
- Non-magnetic and non-conductive
- Measuring instruments and test equipment easily slide over surface



Applications:

- For measuring tasks, layout work, touching up and lapping precision parts
- Recommended assembly (with optional accessories):
 - Up to 400 mm to be used on a workbench with adjustable plate supports 107 Asa
 - From 630 mm to be used with a stand 107 Us or cabinet 107 Ug

TECHNICAL DATA

| Order no. | 4221520 | 4221521 | 4221522 | 4221523 | 4221524 | 4221525 | 4221526 | 4221527 | 4221528 | |
|--------------------|--|-----------|-----------|-----------|-----------|-----------|------------|------------|-------------|-------------|
| Type | 107 G | | | | | | | | | |
| Plate size | mm | 400 x 250 | 400 x 400 | 630 x 400 | 630 x 630 | 800 x 500 | 1000 x 630 | 1200 x 800 | 1500 x 1000 | 2000 x 1000 |
| Plate thickness | mm | 60 | | 80 | | 100 | | 150 | | 200 |
| Standard | DIN 876 | | | | | | | | | |
| Tolerance class | 0 | | | | | | | | | |
| Flatness tolerance | $t_1 = 4 (1 + L/1000) \mu\text{m}$, L in mm | | | | | | | | | |
| Weight | kg | 18 | 29 | 60 | 95 | 120 | 190 | 432 | 675 | 1200 |

ACCESSORIES

| Order no. | Description | Type |
|-----------|---|---------|
| 4221560 | Cabinet underframe with edge protection, 630 x 400 mm | 107 Us |
| 4221570 | Open underframe with edge protection, 630 x 400 mm | 107 Ug |
| 4221069 | Adjustable support element for test plates | 107 Asa |
| 4221561 | Cabinet underframe with edge protection, 630 x 630 mm | 107 Us |
| 4221571 | Open underframe with edge protection, 630 x 630 mm | 107 Ug |
| 4221562 | Cabinet underframe with edge protection, 800 x 500 mm | 107 Us |
| 4221572 | Open underframe with edge protection, 800 x 500 mm | 107 Ug |
| 4221563 | Cabinet underframe with edge protection, 1000 x 630 mm | 107 Us |
| 4221573 | Open underframe with edge protection, 1000 x 630 mm | 107 Ug |
| 4221564 | Cabinet underframe with edge protection, 1200 x 800 mm | 107 Us |
| 4221574 | Open underframe with edge protection, 1200 x 800 mm | 107 Ug |
| 4221565 | Cabinet underframe with edge protection, 1500 x 1000 mm | 107 Us |
| 4221575 | Open underframe with edge protection, 1500 x 1000 mm | 107 Ug |
| 4221566 | Cabinet underframe with edge protection, 2000 x 1000 mm | 107 Us |
| 4221576 | Open underframe with edge protection, 2000 x 1000 mm | 107 Ug |



107G + 107 US



107G + 107 UG

MarStand 107 G

Surface plate made from granite

FEATURES

- Made of choice fine grain black granite (Diabase)
- High density structure is extremely homogeneous
- Hardness 6–7 on the Mohs hardness scale
- Surface plate is lapped and has a satin matt finish to prevent glare
- 100 % corrosion proof
- Non-magnetic and non-conductive
- Measuring instruments and test equipment easily slide over surface



Applications:

- For measuring tasks, layout work, touching up and lapping precision parts
- Recommended assembly (with optional accessories):
 - Up to 400 mm to be used on a workbench with adjustable plate supports 107 Asa
 - From 630 mm to be used with a stand 107 Us or cabinet 107 Ug

TECHNICAL DATA

| Order no. | 4221540 | 4221541 | 4221542 | 4221543 | 4221544 | 4221545 | 4221546 | 4221547 | 4221548 | |
|--------------------|---|-----------|-----------|-----------|-----------|-----------|------------|------------|-------------|-------------|
| Type | 107 G | | | | | | | | | |
| Plate size | mm | 400 x 250 | 400 x 400 | 630 x 400 | 630 x 630 | 800 x 500 | 1000 x 630 | 1200 x 800 | 1500 x 1000 | 2000 x 1000 |
| Plate thickness | mm | 60 | | 80 | | 100 | | 150 | | 200 |
| Standard | DIN 876 | | | | | | | | | |
| Tolerance class | 1 | | | | | | | | | |
| Flatness tolerance | $t_1 = 10 (1 + L/1000) \mu\text{m}$, L in mm | | | | | | | | | |
| Weight | kg | 18 | 29 | 60 | 95 | 120 | 190 | 432 | 675 | 1200 |

ACCESSORIES

| Order no. | Description | Type |
|-----------|---|---------|
| 4221560 | Cabinet underframe with edge protection, 630 x 400 mm | 107 Us |
| 4221570 | Open underframe with edge protection, 630 x 400 mm | 107 Ug |
| 4221069 | Adjustable support element for test plates | 107 Asa |
| 4221561 | Cabinet underframe with edge protection, 630 x 630 mm | 107 Us |
| 4221571 | Open underframe with edge protection, 630 x 630 mm | 107 Ug |
| 4221562 | Cabinet underframe with edge protection, 800 x 500 mm | 107 Us |
| 4221572 | Open underframe with edge protection, 800 x 500 mm | 107 Ug |
| 4221563 | Cabinet underframe with edge protection, 1000 x 630 mm | 107 Us |
| 4221573 | Open underframe with edge protection, 1000 x 630 mm | 107 Ug |
| 4221564 | Cabinet underframe with edge protection, 1200 x 800 mm | 107 Us |
| 4221574 | Open underframe with edge protection, 1200 x 800 mm | 107 Ug |
| 4221565 | Cabinet underframe with edge protection, 1500 x 1000 mm | 107 Us |
| 4221575 | Open underframe with edge protection, 1500 x 1000 mm | 107 Ug |
| 4221566 | Cabinet underframe with edge protection, 2000 x 1000 mm | 107 Us |
| 4221576 | Open underframe with edge protection, 2000 x 1000 mm | 107 Ug |



107G + 107 US



107G + 107 UG

MarStand 818

Radial runout gage with center supports

FEATURES

Unit composed of:

Bench gage:

- Flatness of the surface is in accordance to DIN 876-2
- Two T-slots for tailstock and / or support arm

Support arm 818 XNB:

- Support arm with one joint
- With fine adjustment

Tailstocks:

- Both tailstocks can be relocated (slide into position)
- The tailstock on the right side has a retractable (spring actuated) precision aligned center
- The tailstocks have a peak of height of 75 mm with a 90° prism
- For workpieces without a center, utilizing support arms, the maximum diameter is 20 mm (0.79")
- **Package contains:** measuring bench, measuring arm 818 XNB, center supports, excludes indicator



Applications:

- Fast and easy radial runout testing between tips
- When measuring a shaft between tips, the reference axis for the radial runout measurement is usually identical to the rotational axis during production. A minimal radial runout deviation can therefore be expected during this test procedure.

TECHNICAL DATA

| Order no. | 4622200 | 4622201 | 4622202 | 4622203 |
|-----------------------------------|---------|---------|---------|---------|
| Type | 818 | | | |
| Distance between centers | mm | 0 – 200 | 0 – 350 | 0 – 450 |
| Height of centers | mm | 50 | 75 | 100 |
| T-groove width | mm | 10H7 | | 12H7 |
| Mounting hole | | 8H7 | | |
| Permitted height difference | mm | 0.05 | | |
| Permitted lateral difference | mm | 0.05 | | |
| Max. workpiece load per tailstock | kg | 5 | | 20 |
| Product weight | kg | 8.00 | 12.00 | 35.00 |

| Order no. | A | L | d | Structural dimensions (L x W) mm | Column Ø | Column height |
|-----------|-----|-----|----|----------------------------------|----------|---------------|
| | mm | mm | mm | mm | mm | mm |
| 4622200 | 200 | 350 | 16 | 350 x 110 | 18 | 205 |
| 4622201 | 350 | 500 | 16 | 500 x 110 | 18 | 205 |
| 4622202 | 450 | 700 | 22 | 700 x 180 | 18 | 260 |
| 4622203 | 450 | 700 | 22 | 700 x 180 | 18 | 360 |

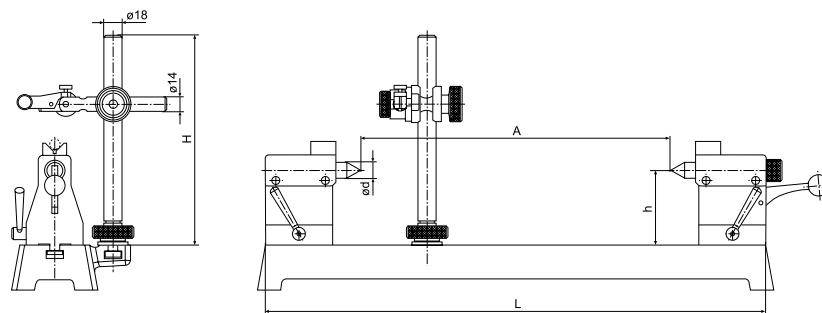

ACCESSORIES

| Order no. | Description | Type |
|-----------|--|---------|
| 4622210 | V-support anvils in pairs, diameter range 3 – 15 mm, suitable for peak height 50 / 75 mm | 818 pe |
| 4622275 | Support arm, column height 205 mm, T-groove width 10 mm | 818 XNB |
| 4622220 | Roller supports in pairs, diameter range 3 – 30 mm, T-groove width 10 mm | 818 ab |
| 4622215 | V-support in pairs, diameter range 5 – 20 mm, T-groove width 10 mm | 818 pb |
| 4622276 | Support arm, column height 260 mm, T-groove width 12 mm | 818 XNB |
| 4622211 | V-support anvils in pairs, diameter range 8 – 45 mm, suitable for peak height 100 mm | 818 pe |
| 4622277 | Support arm, column height 360 mm, T-groove width 12 mm | 818 XNB |
| 4622221 | Roller supports in pairs, diameter range 4 – 60 mm, T-groove width 12 mm | 818 ab |
| 4622216 | V-support in pairs, diameter range 5 – 45 mm, T-groove width 12 mm | 818 pb |



MarStand 818 P

Center bench with V-support

FEATURES

Unit composed of:

Bench gage:

- Flatness of the surface is in accordance to DIN 876/1
- Two T-slots for tailstock and / or support arm

Support arm 818 XNB:

- Support arm with one joint
- With fine adjustment

V-supports:

- Both V-supports can be relocated (slide into position)
- **Package contains:** measuring bench, measuring arm 818 XNB, V-supports, excludes indicator



Applications:

- Fast and easy radial runout testing of V-blocks
- Perfect for parts without a central bore
- During this test procedure, the reference axis is formed by the cylindricity (circumferential surface) of an actual bearing point, e.g. at a transmission shaft. Possible roundness deviations of the cylindrical surface are included in the radial runout measurement result in accordance with the V-angle.
- This test is thus more functional than measuring between the tips.

TECHNICAL DATA

| Order no. | 4622260 | 4622261 | 4622262 | |
|------------------------------|---------|---------|---------|-------|
| Type | 818 P | | | |
| Height of V-supports | mm | 70 | 120 | |
| Diameter range | mm | 5 – 20 | 5 – 45 | |
| T-groove width | mm | 10H7 | 12H7 | |
| Mounting hole | 8H7 | | | |
| Permitted height difference | mm | 0.05 | | |
| Permitted lateral difference | mm | 0.05 | | |
| Product weight | kg | 6.50 | 9.50 | 30.00 |

| Order no. | A | D | L | b | d | Structural dimensions (L x W) mm | Column Ø | Column height |
|-----------|-----|----|-----|------|----|----------------------------------|----------|---------------|
| | mm | mm | mm | mm | mm | mm | mm | mm |
| 4622260 | 315 | 25 | 350 | 9,6 | 5 | 350 x 110 | 18 | 205 |
| 4622261 | 465 | 25 | 500 | 9,6 | 5 | 500 x 110 | 18 | 205 |
| 4622262 | 650 | 50 | 700 | 13,6 | 5 | 700 x 180 | 18 | 260 |

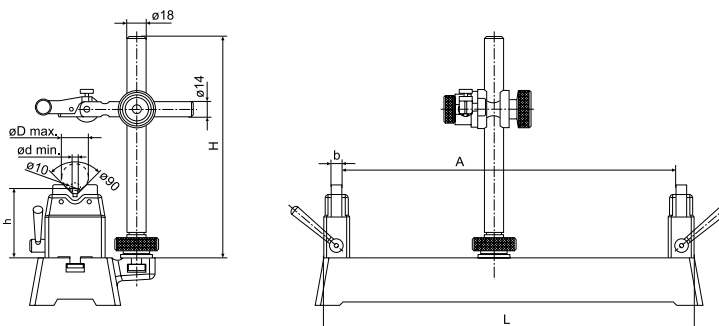

ACCESSORIES

| Order no. | Description | Type |
|-----------|---|---------|
| 4622275 | Support arm, column height 205 mm, T-groove width 10 mm | 818 XNB |
| 4622276 | Support arm, column height 260 mm, T-groove width 12 mm | 818 XNB |
| 4622277 | Support arm, column height 360 mm, T-groove width 12 mm | 818 XNB |

MarStand 818 R

Center bench with roller support

FEATURES

Unit composed of:

Bench gage:

- Flatness of the surface is in accordance to DIN 876/1
- Two T-slots for tailstock and / or support arm

Support arm 818 XNB:

- Support arm with one joint
- With fine adjustment

Roller supports:

- Both roller supports can be relocated (slide into position)
- **Package contains:** measuring bench, measuring arm 818 XNB, balancing supports, excludes indicator



Applications:

- Fast and easy radial runout testing of anti-friction bearing mounted rollers
- Perfect for smooth-running and seamless rotation of the workpiece, especially heavy parts without a central bore
- During this test procedure, the reference axis is formed by the cylindricity (circumferential surface) of an actual bearing point, e.g. at a transmission shaft. Possible roundness deviations of this cylindrical surface can be included in the radial runout measurement result in accordance with the surface angle.
- This test is thus more functional than measuring between the tips.

TECHNICAL DATA

| Order no. | 4622250 | 4622251 | 4622252 | |
|-------------------------------------|---------|---------|---------|-------|
| Type | 818 R | | | |
| Height of roller supports | mm | 65 | 100 | |
| Diameter range | mm | 3 – 30 | 4 – 60 | |
| T-groove width | mm | 10H7 | 12H7 | |
| Mounting hole | 8H7 | | | |
| Permissible radial runout deviation | µm | 3 | 4 | |
| Permitted height difference | mm | 0.05 | | |
| Permitted lateral difference | mm | 0.05 | | |
| Product weight | kg | 6.50 | 9.50 | 30.00 |

| Order no. | A | D | L | b | d | Structural dimensions (L x W) mm | Column Ø | | Column height | |
|-----------|-----|----|-----|----|---|----------------------------------|----------|-----|---------------|----|
| | | | | | | | mm | mm | mm | mm |
| 4622250 | 315 | 25 | 350 | 8 | 3 | 350 x 110 | 18 | 205 | | |
| 4622251 | 465 | 25 | 500 | 8 | 3 | 500 x 110 | 18 | 205 | | |
| 4622252 | 650 | 50 | 700 | 12 | 5 | 700 x 180 | 18 | 260 | | |

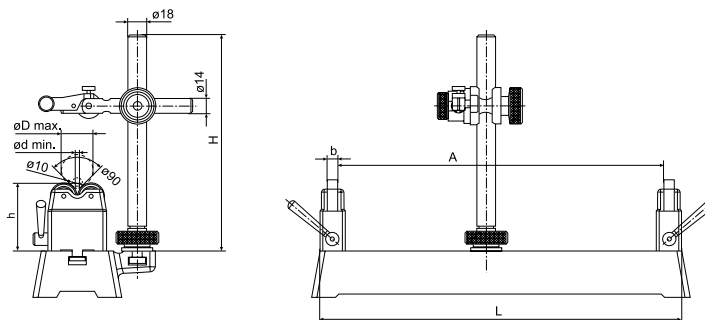

ACCESSORIES

| Order no. | Description | Type |
|-----------|---|---------|
| 4622275 | Support arm, column height 205 mm, T-groove width 10 mm | 818 XNB |
| 4622276 | Support arm, column height 260 mm, T-groove width 12 mm | 818 XNB |
| 4622277 | Support arm, column height 360 mm, T-groove width 12 mm | 818 XNB |

Marameter | Indicating measuring instruments

Marameter is the ideal instrument series for high-precision measurements of inside and outside diameters on individual and serial parts. These indicating measuring instruments obtain the best results due to their constant measuring force, accurate transmission mechanisms and the high parallelism of their measuring surfaces. Marameter also offers compelling solutions for special measuring tasks.



| | |
|--|------------|
| Indicating measuring instruments | |
| External dimensions, precision point snap gage overview | 292 |
| Marameter 840 F / 840 FC / 840 FH / 840 FG / 840 FM Indicating snap gages | 294 |
| Marameter 840 FS For precise measurements of large dimensions | 301 |
| Marameter E series For highly accurate workpieces | 302 |
| Marameter 300P / M-300P / OMI-300P / EDI-301P / EMD-301P / OMI-301P / 301P-series Indicating snap gage | 305 |
| Marameter 852 TS / 852 TZ / 852 / 853 For threads, thread tools, gears | 314 |
| Marameter portable thickness gages | 320 |
| Caliper gages | |
| Marameter 838 TAZ / 838 TA / 838 EA / 838 TI / 838 EI Outer and inner probe with digital and scale display | 332 |
| Comparative measuring instruments for inside dimensions | |
| Marameter 844 D Bore plug gages and accessories | 338 |
| Marameter Dimentron® plug gages | 370 |
| Marameter 844 K Self-centering inner measuring devices, sets and modular system | 380 |
| 844 NB / 844 N / 844 NH Self-centering inner measuring devices | 403 |

Marameter | Indicating snap gages 840 F / 840 FC

The Marameter 840 F / 840 FC indicating snap gages are ideal for highly accurate and reliable results on cylindrical workpieces with a narrow tolerance.

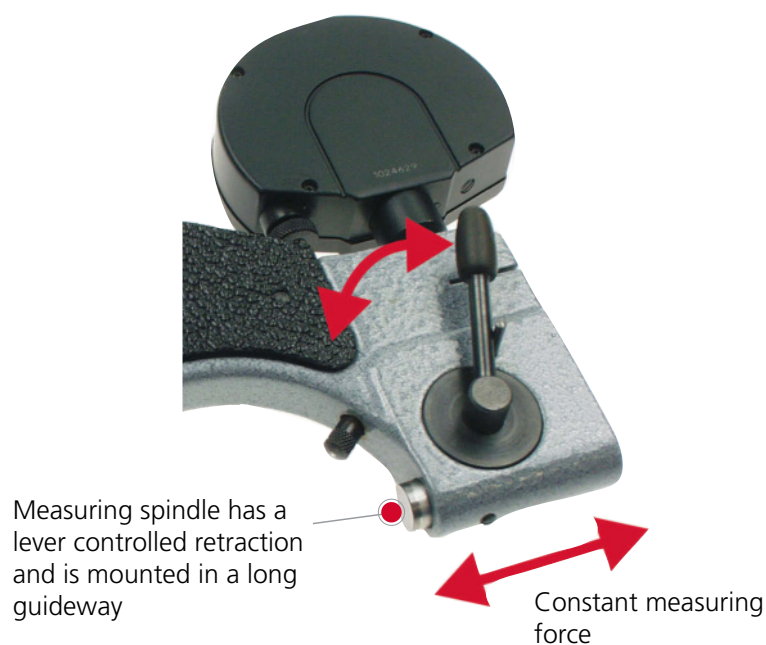
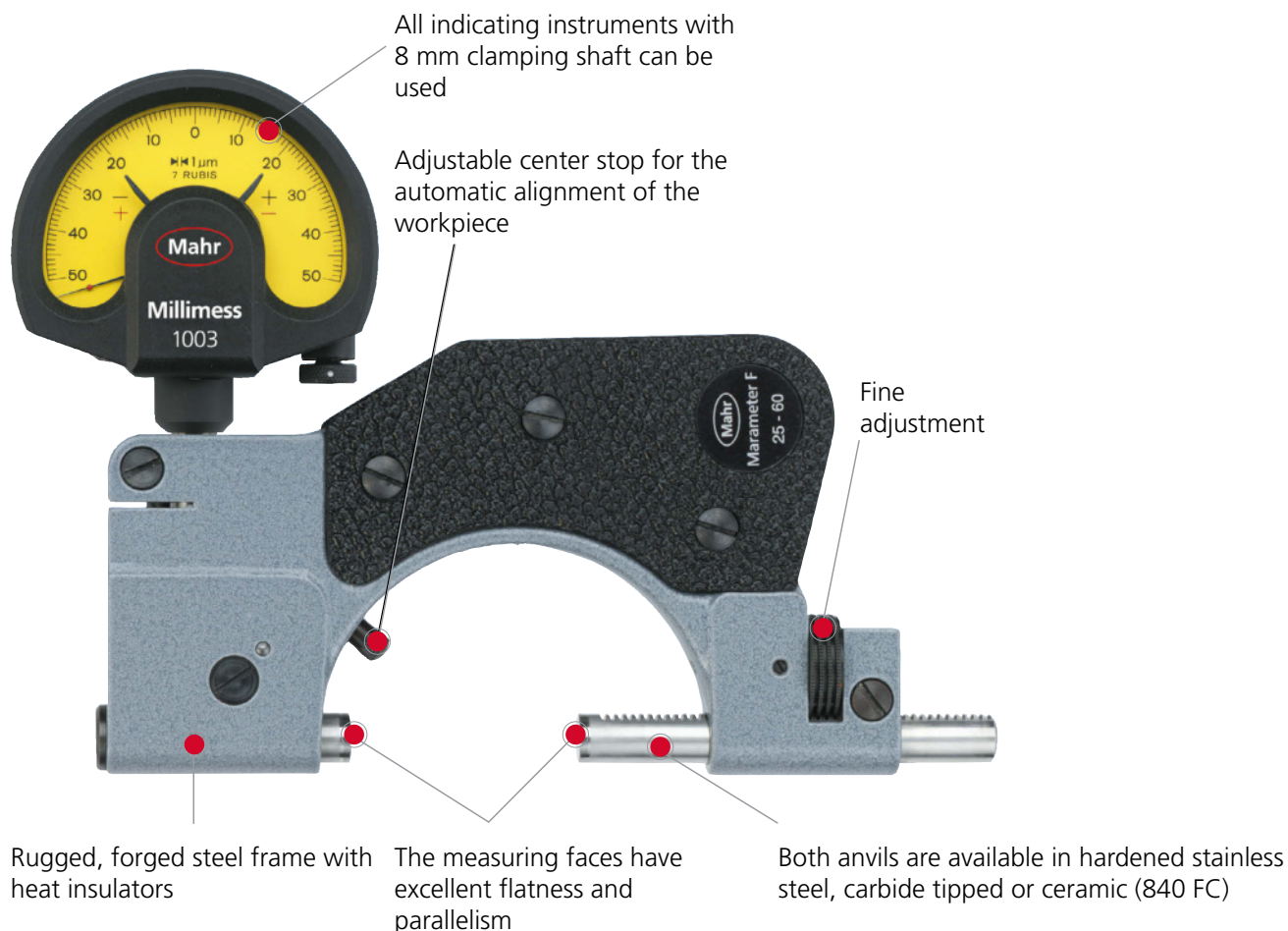

Marameter | Advantages of the 840 F snap gage compared to a micrometer

- Reduced measuring uncertainty

The Marameter indicating snap gages have a notably reduced measuring uncertainty in comparison to a micrometer.

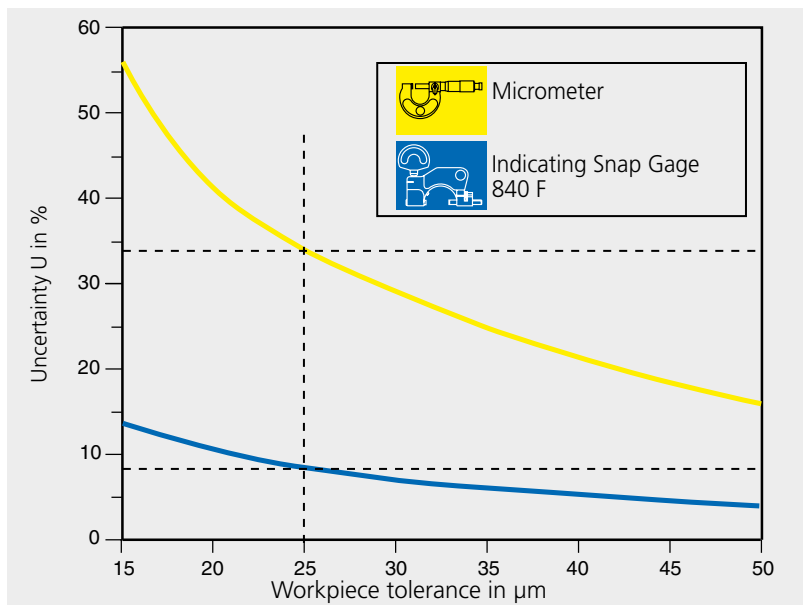

Measuring Uncertainty U is dependent upon the tolerance of the workpiece

- Better utilization of the tolerance zone

Example: Workpiece tolerance 25 μm

The measured value in the uncertainty range can lie outside of the tolerance range, therefore the utilized tolerance of the micrometer is reduced to only 32% (8 μm). With a Marameter 840 F indicating snap gage, 83% (20.8 μm) of the workpiece tolerance can be utilized.

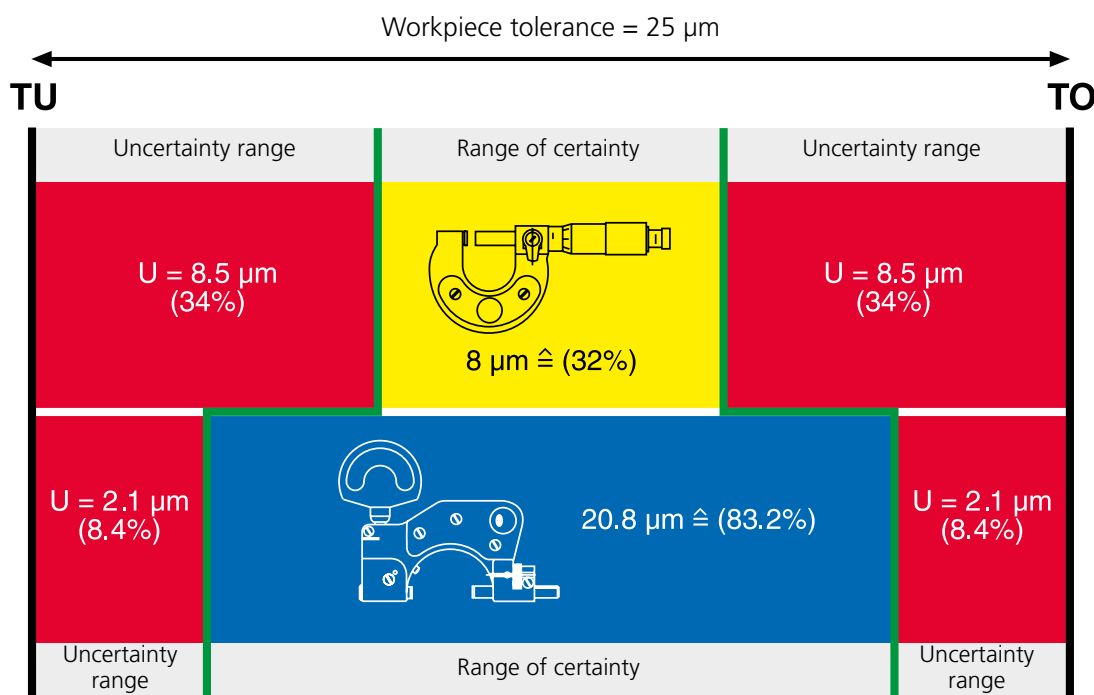

Advantage:

With the indicating snap gage the tolerance zone can be used to a far greater extent, thus reducing production costs.

Marameter 840 F

Indicating snap gage

FEATURES

- Rugged, forged steel frame with heat insulators
- Measuring spindle is mounted in long guideway with lever controlled retraction
- Measuring spindle and anvil are made of hardened stainless steel with carbide tipped measuring faces
- Adjustable centering stop for surface centering
- Anvil spindle can easily be fine adjusted
- Constant measuring force as a result of built-in spring, eliminating user influence
- Maximum wear resistance due to noncontact positioning in conjunction with carbide tipped measuring faces
- **Package contains:** flat contact point 903 (steel), instruction manual, wooden case, excludes indicator



Applications:

- For cylindrical parts such as shafts, bolts and spindles
- For thickness and length measurements
- Universally applicable and extremely versatile
 - Each instrument spans a broad measuring range
 - Any dimension and fit can be very quickly and easily adjusted

TECHNICAL DATA

| Order no. | Type | Applica- tion range | | Measuring span | Parallelism | Flatness | Repeata- bility f_w | Measuring force | Frame size |
|-----------|-------|------------------------|-----------|-------------------|-------------|-----------|--------------------------|--------------------|---------------|
| | | mm | inch | | deviation | deviation | | | |
| 4450000 | 840 F | 0 – 25 | 0 – 1" | 2 | 1 | 0.2 | 0.5 | 7.5 | 1 |
| 4450001 | 840 F | 25 – 60 | 1 – 2.36" | 2 | 2 | 0.2 | 0.5 | 7.5 | 2 |
| 4450002 | 840 F | 50 – 100 | 2 – 4" | 2.5 | 2 | 0.2 | 1 | 7.5 | 3 |
| 4450003 | 840 F | 100 – 150 | 4 – 6" | 2.5 | 2 | 0.2 | 1 | 9 | 4 |
| 4450004 | 840 F | 150 – 200 | 6 – 8" | 2.5 | 2 | 0.2 | 1 | 9 | 5 |

| Order no. | a | b | c | d | e | f | g | h | k | l |
|-----------|-----|-----|-----|----|----|-----|----|----|----|-----|
| | mm | mm | mm | mm | mm | mm | mm | mm | mm | mm |
| 4450000 | 5 | 97 | 34 | 8 | 54 | 65 | 12 | 13 | 23 | 14 |
| 4450001 | 5 | 140 | 68 | 9 | 60 | 77 | 13 | 13 | 25 | 30 |
| 4450002 | 6.5 | 193 | 110 | 10 | 60 | 103 | 14 | 13 | 28 | 54 |
| 4450003 | 6.5 | 258 | 162 | 12 | 70 | 141 | 16 | 12 | 31 | 81 |
| 4450004 | 6.5 | 316 | 212 | 12 | 75 | 171 | 16 | 12 | 31 | 106 |

ACCESSORIES

| Order no. | Description | Type |
|-----------|--|----------|
| 4333000 | Millimess 5 μm , $\pm 130 \mu\text{m}$ | 1004 |
| 4334000 | Millimess 1 μm , $\pm 50 \mu\text{m}$ | 1003 |
| 4334001 | Millimess 2 μm , $\pm 130 \mu\text{m}$ | 1003 XL |
| 4335000 | Millimess 0.5 μm , $\pm 25 \mu\text{m}$ | 1002 |
| 4337620 | Digital indicator, 0.0005 mm, 12.5 mm | 1086 R |
| 4337624 | Digital indicator, 0.0005 mm, 12.5 mm | 1086 Ri |
| 4450020 | Base for stationary application | 840 Ff |
| 4450050 | Holder, frame size 1 | 840 Fk/1 |
| 4450051 | Holder, frame size 2 | 840 Fk/2 |
| 4450052 | Holder, frame size 3 | 840 Fk/3 |
| 4450053 | Holder, frame size 4 + 5 | 840 Fk/4 |



1086 R



840 Fk/2



1004



1003



1002

Marameter 840 FC

Indicating snap gage

FEATURES

- Rugged, forged steel frame with heat insulators
- Measuring spindle is mounted in long guideway with lever controlled retraction
- Measuring spindle and anvil spindle are both made of hardened stainless steel, ceramic measuring faces
- Adjustable centering stop for surface centering
- Anvil spindle can easily be fine adjusted
- Constant measuring force as a result of built-in spring, eliminating user influence
- Maximum wear resistance due to noncontact positioning in conjunction with carbide tipped measuring faces in connection with ceramic measuring faces
- **Package contains:** flat contact point 903 (steel), instruction manual, wooden case, excludes indicator



Applications:

- For cylindrical parts such as shafts, bolts and spindles
- For thickness and length measurements
- Universally applicable and extremely versatile
 - Each instrument spans a broad measuring range
 - Any dimension and fit can be very quickly and easily adjusted

TECHNICAL DATA

| Order no. | Type | Applica- tion range mm | Applica- tion range inch | Measuring span mm | Parallelism deviation µm | Flatness deviation µm | Repeata- bility f _w µm | Measuring force N | Frame size |
|-----------|--------|------------------------------|--------------------------------|-------------------------|--------------------------------|-----------------------------|---|-------------------------|---------------|
| 4450100 | 840 FC | 0–25 | 0–1" | 2 | 1 | 0.2 | 1 | 7.5 | 1 |
| 4450101 | 840 FC | 25–60 | 1–2.36" | 2 | 2 | 0.2 | 1 | 7.5 | 2 |

| Order no. | a | b | c | d | e | f | g | h | k | l |
|-----------|----|-----|----|----|----|----|----|----|----|----|
| | mm | mm | mm | mm | mm | mm | mm | mm | mm | mm |
| 4450100 | 5 | 97 | 34 | 8 | 54 | 65 | 12 | 13 | 23 | 14 |
| 4450101 | 5 | 140 | 68 | 9 | 60 | 77 | 13 | 13 | 25 | 30 |

ACCESSORIES

| Order no. | Description | Type |
|-----------|---------------------------------------|----------|
| 4333000 | Millimess 5 µm, ± 130 µm | 1004 |
| 4334000 | Millimess 1 µm, ± 50 µm | 1003 |
| 4334001 | Millimess 2 µm, ± 130 µm | 1003 XL |
| 4335000 | Millimess 0.5 µm, ± 25 µm | 1002 |
| 4337620 | Digital indicator, 0.0005 mm, 12.5 mm | 1086 R |
| 4337624 | Digital indicator, 0.0005 mm, 12.5 mm | 1086 Ri |
| 4450020 | Base for stationary application | 840 Ff |
| 4450050 | Holder, frame size 1 | 840 Fk/1 |
| 4450051 | Holder, frame size 2 | 840 Fk/2 |



Marameter 840 FH

Indicating snap gage

FEATURES

- Rugged, forged steel frame with heat insulators
- Measuring spindle is mounted in long guideway with lever controlled retraction
- Measuring and anvil spindle have precision tapered bores for mounting interchangeable anvils (with accessory 40 He)
- Anvil spindle can easily be fine adjusted
- Constant measuring force as a result of built-in spring, eliminating user influence
- Maximum wear resistance due to noncontact positioning in conjunction with carbide tipped measuring faces
- **Package contains:** flat contact point 903 (steel), spanner DIN 902–3.5, wooden case, excludes indicator

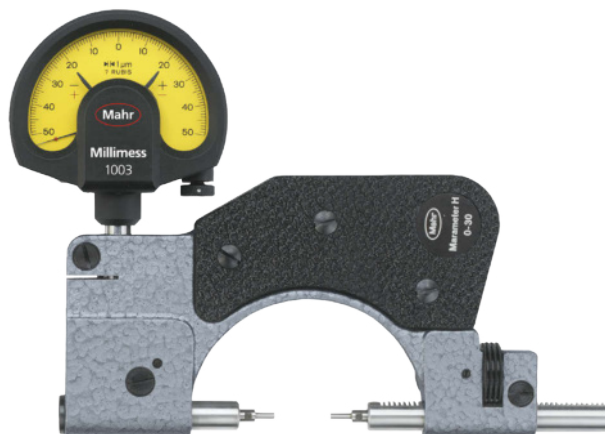

Applications:

- For cylindrical parts such as shafts, bolts and spindles
- Universally applicable
- A wide variety of measurement problems can be solved with the broad range of interchangeable anvils

TECHNICAL DATA

| Order no. | Type | Application range | Application range | Measuring span | Repeatability f_w | Measuring force | Frame size |
|-----------|--------|-------------------|-------------------|----------------|---------------------|-----------------|------------|
| | | mm | inch | mm | μm | N | |
| 4451000 | 840 FH | 0–30 | 0–1.18" | 2 | 1 | 7.5 | 2 |
| 4451005 | 840 FH | 30–80 | 1.18–3" | 2.5 | 1 | 7.5 | 3 |

| Order no. | a | b | c | d | e | f | g | h | k | l | n |
|-----------|------|-----|-----|----|----|-----|----|----|----|----|-----|
| | mm | mm | mm | mm | mm | mm | mm | mm | mm | mm | mm |
| 4451000 | 12.5 | 140 | 68 | 9 | 60 | 77 | 13 | 13 | 25 | 34 | 2 |
| 4451005 | 7.5 | 193 | 110 | 10 | 60 | 103 | 13 | 13 | 28 | 59 | 2.5 |

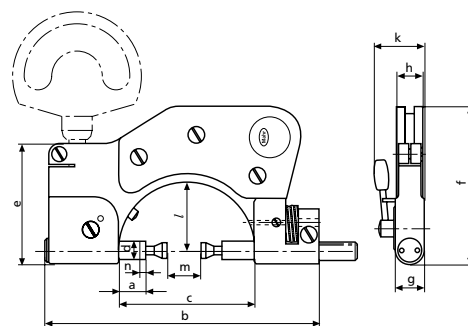

Marameter 840 FH

Indicating snap gage

ACCESSORIES

| Order no. | Description | Type |
|-----------|--|----------|
| 4333000 | Millimess 5 μm , $\pm 130 \mu\text{m}$ | 1004 |
| 4334000 | Millimess 1 μm , $\pm 50 \mu\text{m}$ | 1003 |
| 4334001 | Millimess 2 μm , $\pm 130 \mu\text{m}$ | 1003 XL |
| 4335000 | Millimess 0.5 μm , $\pm 25 \mu\text{m}$ | 1002 |
| 4337620 | Digital indicator, 0.0005 mm, 12.5 mm | 1086 R |
| 4337624 | Digital indicator, 0.0005 mm, 12.5 mm | 1086 Ri |
| 4880210 | Spanner for 840 FH, to loosen anvils | |
| 4450051 | Holder, frame size 2 | 840 Fk/2 |
| 4450020 | Base for stationary application | 840 Ff |
| 4152036 | Measuring anvils, end faces, carbide design | 40 He 0H |
| 4152011 | Measuring anvils, recessed plane surfaces | 40 He 1 |
| 4152033 | Measuring anvils, recessed end faces, carbide | 40 He 1H |
| 4152012 | Measuring anvils, recessed plane surfaces | 40 He 2 |
| 4152031 | Measuring anvils, recessed end faces, carbide | 40 He 2H |
| 4152013 | Measuring anvils, disk-shaped measuring surfaces | 40 He 3 |
| 4152014 | Measuring anvils, disk-shaped measuring surfaces with V-shaped grooves | 40 He 4 |
| 4152015 | Measuring anvils, measuring blades | 40 He 5 |
| 4152016 | Measuring anvils, wing-shaped measuring surfaces | 40 He 6 |
| 4152017 | Measuring anvils, recessed measuring blades | 40 He 7 |
| 4152018 | Measuring anvils, recessed end faces with V-grooves on sleeve | 40 He 8 |
| 4152019 | Measuring anvils, recessed end faces with attachable support table | 40 He 9 |
| 4152020 | Measuring anvils, with centric bores | 40 He 10 |
| 4152021 | Measuring anvils, with tips | 40 He 11 |
| 4450052 | Holder, frame size 3 | 840 Fk/3 |



1004



1003



1002



1086 R



840 Fk/2

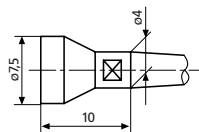

40 He 0H

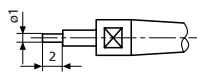

40 He 1; 40 He 1H

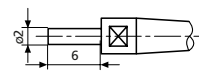

40 He 2; 40 He 2H

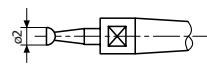

40 He 3

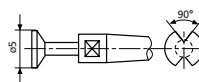

40 He 4

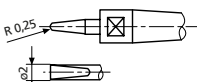

40 He 5

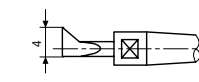

40 He 6

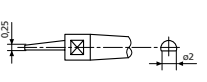

40 He 7

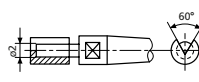

40 He 8

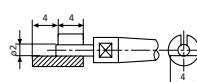

40 He 9

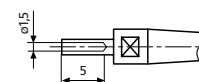

40 He 10

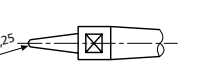

40 He 11

Marameter 840 FG

Indicating snap gage

FEATURES

- Rugged, forged steel frame with heat insulators
- Measuring spindle is mounted in long guideway with lever controlled retraction
- Measuring spindle and anvil spindle have an M 2.5 connection thread, thus enabling the use of interchangeable anvils that are also used in dial indicators and dial comparators
- Anvil spindle can easily be fine adjusted
- Constant measuring force as a result of built-in spring, eliminating user influence
- Maximum wear resistance due to noncontact positioning in conjunction with carbide tipped measuring faces
- Package contains: flat contact point 903 (steel), wooden case, excludes indicator



Applications:

- For cylindrical parts such as shafts, bolts and spindles
- Universally applicable
- A wide variety of measurement problems can be solved with the broad range of interchangeable anvils

TECHNICAL DATA

| Order no. | Type | Application range mm | Application range inch | Measuring span mm | Repeatability f_w μm | Measuring force N | Frame size |
|-----------|--------|-------------------------|---------------------------|----------------------|--------------------------------------|----------------------|------------|
| 4454000 | 840 FG | 0 –50 | 0 –2" | 2 | 1 | 7.5 | 2 |
| 4454001 | 840 FG | 40 –90 | 1.57 –3.57" | 2.5 | 1 | 7.5 | 3 |

| Order no. | a | b | c | d | e | f | g | h | k | l | n |
|-----------|-----|-----|-----|----|----|-----|----|----|----|----|-----|
| | mm | mm | mm | mm | mm | mm | mm | mm | mm | mm | mm |
| 4454000 | 5 | 140 | 68 | 9 | 60 | 77 | 13 | 13 | 25 | 34 | 2 |
| 4454001 | 6.5 | 193 | 110 | 10 | 60 | 103 | 14 | 13 | 28 | 59 | 2.5 |

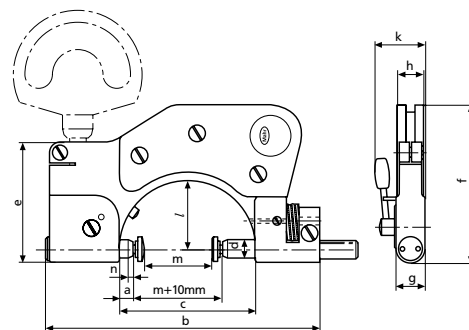

Marameter 840 FG

Indicating snap gage

ACCESSORIES

| Order no. | Description | Type |
|-----------|---|----------|
| 4333000 | Millimess 5 μm , $\pm 130 \mu\text{m}$ | 1004 |
| 4334000 | Millimess 1 μm , $\pm 50 \mu\text{m}$ | 1003 |
| 4334001 | Millimess 2 μm , $\pm 130 \mu\text{m}$ | 1003 XL |
| 4335000 | Millimess 0.5 μm , $\pm 25 \mu\text{m}$ | 1002 |
| 4337620 | Digital indicator, 0.0005 mm, 12.5 mm | 1086 R |
| 4337624 | Digital indicator, 0.0005 mm, 12.5 mm | 1086 Ri |
| 4450051 | Holder, frame size 2 | 840 Fk/2 |
| 4450020 | Base for stationary application | 840 Ff |
| 4360002 | Standard contact point, carbide, $r = 1.5 \text{ mm}$ | 901 H |
| 4360041 | Spherical contact point, carbide, $l = 10 \text{ mm}$, $r = 6 \text{ mm}$ | 902 H |
| 4360043 | Spherical contact point, carbide, $l = 15 \text{ mm}$, $r = 6 \text{ mm}$ | 902 H |
| 4360044 | Spherical contact point, carbide, $l = 20 \text{ mm}$, $r = 6 \text{ mm}$ | 902 H |
| 4360101 | Flat contact point, carbide, $l = 6 \text{ mm}$ | 903 H |
| 4360103 | Flat contact point, carbide, $l = 10 \text{ mm}$ | 903 H |
| 4360105 | Flat contact point, carbide, $l = 15 \text{ mm}$ | 903 H |
| 4360106 | Flat contact point, carbide, $l = 20 \text{ mm}$ | 903 H |
| 4360131 | Conical contact point, carbide, $r = 0.3 \text{ mm}$ | 904 H |
| 4360150 | Ball contact points, carbide, $l = 8.5 \text{ mm}$, $d = 1.0 \text{ mm}$ | 906 H |
| 4360151 | Ball contact points, carbide, $l = 8.5 \text{ mm}$, $d = 1.25 \text{ mm}$ | 906 H |
| 4360152 | Ball contact points, carbide, $l = 8.5 \text{ mm}$, $d = 1.5 \text{ mm}$ | 906 H |
| 4360153 | Ball contact points, carbide, $l = 8.5 \text{ mm}$, $d = 1.75 \text{ mm}$ | 906 H |
| 4360154 | Ball contact points, carbide, $l = 8.5 \text{ mm}$, $d = 2.0 \text{ mm}$ | 906 H |
| 4360155 | Ball contact points, carbide, $l = 8.5 \text{ mm}$, $d = 2.5 \text{ mm}$ | 906 H |
| 4360156 | Ball contact points, carbide, $l = 8.5 \text{ mm}$, $d = 3.0 \text{ mm}$ | 906 H |
| 4360157 | Ball contact points, carbide, $l = 8.5 \text{ mm}$, $d = 3.5 \text{ mm}$ | 906 H |
| 4360158 | Ball contact points, carbide, $l = 8.5 \text{ mm}$, $d = 4.0 \text{ mm}$ | 906 H |
| 4360159 | Ball contact points, carbide, $l = 8.5 \text{ mm}$, $d = 4.5 \text{ mm}$ | 906 H |
| 4360160 | Ball contact points, carbide, $l = 9 \text{ mm}$, $d = 5.0 \text{ mm}$ | 906 H |
| 4360161 | Ball contact points, carbide, $l = 9 \text{ mm}$, $d = 5.5 \text{ mm}$ | 906 H |
| 4360162 | Ball contact points, carbide, $l = 9 \text{ mm}$, $d = 6 \text{ mm}$ | 906 H |
| 4360163 | Ball contact points, carbide, $l = 9 \text{ mm}$, $d = 6.35 \text{ mm}$ | 906 H |
| 4360164 | Ball contact points, carbide, $l = 10 \text{ mm}$, $d = 6.5 \text{ mm}$ | 906 H |
| 4360165 | Ball contact points, carbide, $l = 10 \text{ mm}$, $d = 7 \text{ mm}$ | 906 H |
| 4360166 | Ball contact points, carbide, $l = 11 \text{ mm}$, $d = 7.5 \text{ mm}$ | 906 H |
| 4360167 | Ball contact points, carbide, $l = 11 \text{ mm}$, $d = 8.0 \text{ mm}$ | 906 H |
| 4360168 | Ball contact points, carbide, $l = 12 \text{ mm}$, $d = 8.5 \text{ mm}$ | 906 H |
| 4360169 | Ball contact points, carbide, $l = 12 \text{ mm}$, $d = 9.0 \text{ mm}$ | 906 H |
| 4360170 | Ball contact points, carbide, $l = 13 \text{ mm}$, $d = 10.0 \text{ mm}$ | 906 H |
| 4360200 | Flat contact plates, steel, measuring surface $\varnothing 11.3 \text{ mm}$ | 907 |
| 4360201 | Flat contact plates, carbide, measuring surface $\varnothing 7 \text{ mm}$ | 907 H |
| 4360210 | Spherical contact plates, steel, steel, measuring surface $\varnothing 12 \text{ mm}$ | 908 |
| 4360211 | Spherical contact plates, steel, carbide, measuring surface $\varnothing 12 \text{ mm}$ | 908 H |
| 4360240 | Pin contact point, carbide, $l = 2 \text{ mm}$, measuring surface $\varnothing 1 \text{ mm}$ | 911 H1 |
| 4450052 | Holder, frame size 3 | 840 Fk/3 |



1004



1003



1002



1086 R



840 Fk/2

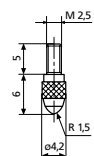

901 H;901;901 R

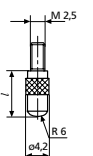

902;902 H

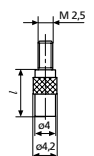

903 H;903

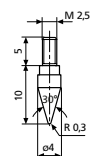

904;904 H

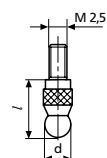

906 H

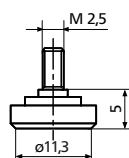

907

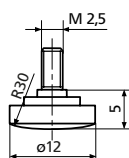

908;908 H

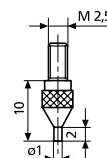

911 H1

Marameter 840 FM

Indicating snap gage

FEATURES

- Rugged, forged steel frame with heat insulators
- Measuring spindle is mounted in long guideway with lever controlled retraction
- Measuring spindle and anvil spindle made of hardened stainless steel; with extending carbide tipped measuring jaws
- Anvil spindle can easily be fine adjusted
- Constant measuring force as a result of built-in spring, eliminating user influence
- Maximum wear resistance due to noncontact positioning in conjunction with carbide tipped measuring faces in conjunction with carbide tipped measuring faces
- **Package contains:** flat contact point 903 (steel), instruction manual, wooden case, excludes indicator

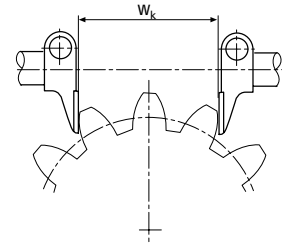
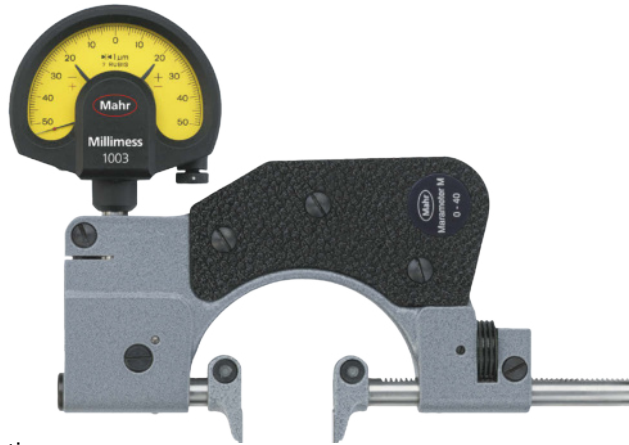

Applications:

- For inspection of diameters of small hubs, registers and shoulders on shafts
- Can be used to inspect tooth span W_k and reference-free tooth thickness on spur gears having straight and helical teeth
- Universally applicable and extremely versatile, each instrument offers long measuring range within its adjustable range

TECHNICAL DATA

| Order no. | | 4452000 | 4452001 | 4452002 | 4452003 |
|---|---------------|------------|-----------|------------|-----------|
| Type | | 840 FM | | | |
| Application range | mm | 0 – 40 | 40 – 80 | 80 – 130 | 130 – 180 |
| Application range | inch | 0 – 1.57" | 1.57 – 3" | 3 – 5" | 5 – 7" |
| Base tangent lengths starting from module m | | 0.5 | | 1 | |
| Size of measuring surface | | 12 x 12 mm | | 15 x 17 mm | |
| Measuring span | mm | 2 | | 2.5 | |
| Parallelism deviation | μm | 2 | | 3 | |
| Flatness deviation | μm | | | 0.5 | |
| Repeatability f_w | μm | | | 1 | |
| Measuring force | N | 7.5 | | 9 | |
| Frame size | | 2 | 3 | 4 | 5 |

| Order no. | a | b | c | e | f | g | h | k | l | m | p | t |
|-----------|----|-----|-----|----|-----|----|----|----|-----|----|----|----|
| | mm | mm | mm | mm | mm | mm | mm | mm | mm | mm | mm | mm |
| 4452000 | 14 | 140 | 68 | 60 | 77 | 13 | 13 | 25 | 34 | 12 | 12 | 11 |
| 4452001 | 14 | 193 | 110 | 60 | 103 | 14 | 13 | 28 | 59 | 12 | 12 | 11 |
| 4452002 | 19 | 258 | 162 | 70 | 141 | 16 | 20 | 31 | 87 | 17 | 15 | 17 |
| 4452003 | 15 | 316 | 212 | 75 | 171 | 16 | 20 | 31 | 112 | 17 | 15 | 17 |

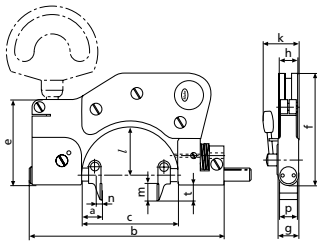

ACCESSORIES

| Order no. | Description | Type |
|-----------|--|----------|
| 4333000 | Millimess 5 μm , $\pm 130 \mu\text{m}$ | 1004 |
| 4334000 | Millimess 1 μm , $\pm 50 \mu\text{m}$ | 1003 |
| 4334001 | Millimess 2 μm , $\pm 130 \mu\text{m}$ | 1003 XL |
| 4335000 | Millimess 0.5 μm , $\pm 25 \mu\text{m}$ | 1002 |
| 4337620 | Digital indicator, 0.0005 mm, 12.5 mm | 1086 R |
| 4337624 | Digital indicator, 0.0005 mm, 12.5 mm | 1086 Ri |
| 4450051 | Holder, Frame size 2 | 840 Fk/2 |
| 4450020 | Base for stationary application | 840 Ff |
| 4450052 | Holder, frame size 3 | 840 Fk/3 |
| 4450053 | Holder, frame size 4 + 5 | 840 Fk/4 |



1004



1003



1002



1086 R



840 Fk/2

Marameter 840 FS

Indicating snap gage

FEATURES

- Rugged, forged steel frame with heat insulators
- Both spindles are made of hardened stainless steel and mounted in long guideways
- Carbide tipped measuring faces slightly chamfered at the front to facilitate positioning
- Projects over width of frame for measurement of narrow registers or when measuring directly at shoulders
- Adjustable centering stop for surface centering
- Straight transfer of spindle movement to indicator; ensures the weight of the gage rests on the anvil spindle
- Direct indication and evaluation of measurement results
- Constant measuring force as a result of built-in spring, eliminating user influence
- **Package contains:** wooden case, allen key, excludes indicator



Applications:

- For all kinds of cylindrical workpieces, whether directly on a machine tool or production control
- Universally applicable and extremely versatile
 - Each instrument spans a broad measuring range
 - Any dimension and fit can be very quickly and easily adjusted

TECHNICAL DATA

| Order no. | Product weight | Type | Applica- tion range | | Measuring span | Parallelism deviation | Flatness deviation | Repeata- bility f _w | Measuring force |
|-----------|----------------|--------|------------------------|-------------|----------------|-----------------------|--------------------|-----------------------------------|-----------------|
| | | | mm | inch | | | | | |
| 4455000 | 0.60 | 840 FS | 10 –30 | .39 –1.18" | 0.7 | 3 | 0.5 | 1 | 13.5 |
| 4455001 | 0.90 | 840 FS | 30 –60 | 1.18 –2.36" | 0.7 | 3 | 0.5 | 1 | 13.5 |
| 4455002 | 1.30 | 840 FS | 60 –100 | 2.36 –4" | 0.7 | 3 | 0.5 | 1 | 13.5 |
| 4455003 | 1.70 | 840 FS | 100 –150 | 4 –6" | 0.7 | 3 | 0.5 | 1 | 15 |
| 4455004 | 2.00 | 840 FS | 150 –200 | 6 –8" | 0.7 | 3 | 0.5 | 1 | 15 |
| 4455005 | 2.20 | 840 FS | 200 –250 | 8 –10" | 0.7 | 3 | 0.5 | 1 | 15 |
| 4455006 | 2.50 | 840 FS | 250 –300 | 10 –12" | 0.7 | 3 | 0.5 | 1 | 15 |
| 4455007 | 3.30 | 840 FS | 300 –350 | 12 –14" | 0.7 | 4 | 0.5 | 1 | 15 |
| 4455008 | 3.30 | 840 FS | 350 –400 | 14 –16" | 0.7 | 4 | 0.5 | 1 | 15 |
| 4455009 | 4.30 | 840 FS | 400 –450 | 16 –18" | 0.7 | 4 | 0.5 | 1 | 15 |
| 4455010 | 4.70 | 840 FS | 450 –500 | 18 –20" | 0.7 | 4 | 0.5 | 1 | 15 |

| Order no. | a | b | c | d | e | f | g | h |
|-----------|----|----|-----|----|-----|-----|----|----|
| 4455000 | 37 | 46 | 154 | 18 | 87 | 161 | 17 | 15 |
| 4455001 | 45 | 51 | 199 | 18 | 122 | 196 | 17 | 15 |
| 4455002 | 56 | 62 | 260 | 22 | 154 | 228 | 20 | 18 |
| 4455003 | 71 | 62 | 335 | 22 | 189 | 263 | 20 | 18 |
| 4455004 | 71 | 62 | 385 | 22 | 214 | 288 | 20 | 18 |
| 4455005 | 71 | 62 | 436 | 22 | 248 | 322 | 20 | 18 |
| 4455006 | 71 | 62 | 487 | 22 | 280 | 354 | 20 | 18 |
| 4455007 | 71 | 62 | 537 | 22 | 310 | 384 | 20 | 18 |
| 4455008 | 71 | 62 | 587 | 22 | 350 | 424 | 20 | 18 |
| 4455009 | 71 | 62 | 637 | 22 | 380 | 454 | 20 | 18 |
| 4455010 | 71 | 62 | 687 | 22 | 410 | 484 | 20 | 18 |

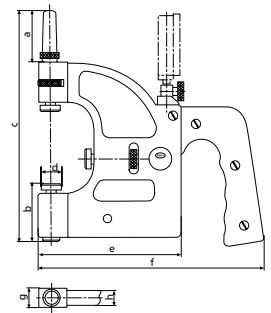

ACCESSORIES

| Order no. | Description | Type |
|-----------|---------------------------------------|---------|
| 4335000 | Millimess 0.5 μm, ± 25 μm | 1002 |
| 4334000 | Millimess 1 μm, ± 50 μm | 1003 |
| 4334001 | Millimess 2 μm, ± 130 μm | 1003 XL |
| 4333000 | Millimess 5 μm, ± 130 μm | 1004 |
| 4337620 | Digital indicator, 0.0005 mm, 12.5 mm | 1086 R |
| 4337624 | Digital indicator, 0.0005 mm, 12.5 mm | 1086 Ri |



1004



1003



1002



1086 R

Marameter 840 E

Indicating snap gage

FEATURES

- Extremely accurate due to the straight transfer of spindle movement to the inductive measuring system according to the Abbe principle
- **Universally applicable and extremely versatile:**
 - Each instrument spans a broad measuring range
 - Any dimension and fit can be very quickly and easily adjusted
- Constant measuring force as a result of built-in spring, eliminating user influence
- Maximum wear resistance due to noncontact positioning in conjunction with carbide tipped measuring faces
- **Package contains:** wooden case, excludes indicator



Application:

- For ultra-accurate measurements on precision components (diameter, thickness and length measurements)

TECHNICAL DATA

| Order no. | Type | Application range | Readings/Selectable resolution down to | Measuring surface ϕ | Measuring span | Parallelism deviation | Repeatability f_w | Measuring force | Frame size 3 |
|-----------|-------|-------------------|--|--------------------------|----------------|-----------------------|----------------------|-----------------|--------------|
| 4453000 | 840 E | mm 0 – 25 | μm 0.01 | mm 7.5 | mm 0.5 | μm 0.3 | μm 0.1 | N 4.5 | 1 |

ACCESSORIES

| Order no. | Description | Type |
|-----------|---------------------------------|-------------|
| 5312010 | Compact amplifier | C 1200 |
| 5312025 | Compact amplifier | C 1202 |
| 5331120 | Module for inductive probes | N 1702 M |
| 5331125 | Module for inductive probes | N 1702 M-HR |
| 4450020 | Base for stationary application | 840 Ff |



C 1200



C 1202



N 1702 M

Marameter EDI-300P-1 ... EDI-300P-9

Indicating snap gage

FEATURES

- Patented "Channel Lock" design assures precise parallel anvil surfaces throughout the full 25 mm / 1" range of adjustment
- All 300P series snap gages are fully adjustable with positive position locking at any point within the range
- 0.50 mm / .020" movement of sensitive contact
- Snap gages available over a wide range of sizes, styles, and readout configurations
- Large 15.5 mm / .61" square tungsten carbide anvils provide flat, parallel, working surfaces ensuring precision that lasts
- Indicator can be rotated to read from front or rear of the gage
- All adjustments accomplished using a single hex wrench (included)
- **Package contains:** allen key

Applications:

- For rapid measurements of cylindrical parts such as shafts, bolts and spindles
- For thickness and length measurements



TECHNICAL DATA

| Order no. | Type | Measuring range | Application range | Measuring span | Size of measuring surface | Measuring span | Parallelism deviation | Measuring force | Mounting hole for indicator | Lifting lever | Indicating instrument (included in package) |
|-----------|------------|-----------------|-------------------|----------------|---------------------------|----------------|-----------------------|-----------------|-----------------------------|---------------|---|
| | | inch | mm | inch | mm | mm | µm | N | inch | | |
| 2051658 | EDI-300P-1 | 0 - 1" | 0 - 25.4 | 0.02 | 15.5 x 15.5 | 0.5 | 4 | 18 | .375" | - | 2034201 µMaxµm-II |
| 2051664 | EDI-300P-2 | 1 - 2" | 25.4 - 50.8 | 0.02 | 15.5 x 15.5 | 0.5 | 4 | 18 | .375" | - | 2034201 µMaxµm-II |
| 2051666 | EDI-300P-3 | 2 - 3" | 50.8 - 76.2 | 0.02 | 15.5 x 15.5 | 0.5 | 4 | 18 | .375" | - | 2034201 µMaxµm-II |
| 2051668 | EDI-300P-4 | 3 - 4" | 76.2 - 101.6 | 0.02 | 15.5 x 15.5 | 0.5 | 4 | 18 | .375" | - | 2034201 µMaxµm-II |
| 2051669 | EDI-300P-5 | 4 - 5" | 101.6 - 127 | 0.02 | 15.5 x 15.5 | 0.5 | 4 | 18 | .375" | - | 2034201 µMaxµm-II |
| 2051670 | EDI-300P-6 | 5 - 6" | 127 - 152.4 | 0.02 | 15.5 x 15.5 | 0.5 | 4 | 18 | .375" | - | 2034201 µMaxµm-II |
| 2051671 | EDI-300P-7 | 6 - 7" | 152.4 - 177.8 | 0.02 | 15.5 x 15.5 | 0.5 | 4 | 18 | .375" | - | 2034201 µMaxµm-II |
| 2051672 | EDI-300P-8 | 7 - 8" | 177.8 - 203.2 | 0.02 | 15.5 x 15.5 | 0.5 | 4 | 18 | .375" | - | 2034201 µMaxµm-II |
| 2051673 | EDI-300P-9 | 8 - 9" | 203.2 - 228.6 | 0.02 | 15.5 x 15.5 | 0.5 | 4 | 18 | .375" | - | 2034201 µMaxµm-II |

| Order no. | a | b | c | d | e |
|-----------|-------|-----|----|-----|-----|
| | mm | mm | mm | mm | mm |
| 2051658 | 25.4 | 150 | 29 | 145 | 158 |
| 2051664 | 50.8 | 175 | 29 | 141 | 154 |
| 2051666 | 76.2 | 200 | 29 | 155 | 167 |
| 2051668 | 101.6 | 226 | 29 | 167 | 180 |
| 2051669 | 127 | 251 | 29 | 180 | 193 |
| 2051670 | 152.4 | 278 | 30 | 203 | 215 |
| 2051671 | 177.8 | 303 | 30 | 213 | 226 |
| 2051672 | 203.2 | 329 | 30 | 231 | 244 |
| 2051673 | 228.6 | 335 | 30 | 248 | 261 |

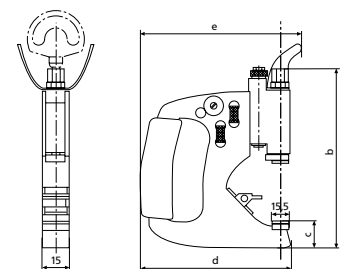

ACCESSORIES

| Order no. | Description | Type |
|-----------|--|---------|
| 2003150 | Base/bench stand for 300P or 1000P style snap gage | BA-26 |
| 2202272 | Plain anvil (lower), left (option) | AL-1755 |
| 2202273 | Plain anvil (upper), left (option) | AL-1756 |
| 2202274 | Plain anvil (lower), right (option) | AL-1757 |
| 2202275 | Plain anvil (lower), right (option) | AL-1758 |
| 2202276 | Plain anvil (lower), middle (option) | AL-1759 |
| 2202277 | Plain anvil (lower), middle (option) | AL-1760 |
| 2204644 | Bench stand for AGD style 3 disc masters up to 127 mm / 5" | BA-71 |
| 2232441 | Heavier force spring for EMD-30XP | SP-118 |
| 2232478 | Lighter force spring for EMD-30XP | SP-192 |
| 2243295 | Lighter force spring for EDI-30XP | 2243295 |
| 2243297 | Heavier force spring for EDI-30XP | 2243297 |

Marameter EMD-300P-1D ... EMD-300P-9D

Indicating snap gage



FEATURES

- Patented "Channel Lock" design assures precise parallel anvil surfaces throughout the full 25 mm / 1" range of adjustment
- All 300P series snap gages are fully adjustable with positive position locking at any point within the range
- 0.50 mm / .020" movement of sensitive contact
- Snap gages available over a wide range of sizes, styles, and readout configurations
- Large 15.5 mm / .61" square tungsten carbide anvils provide flat, parallel, working surfaces ensuring precision that lasts
- Indicator can be rotated to read from front or rear of the gage
- All adjustments accomplished using a single hex wrench (included)
- **Data interface:** Digimatic, RS-232C, USB
- **Energy supply:** battery operation
- **Package contains:** allen key

Applications:

- For rapid measurements of cylindrical parts such as shafts, bolts and spindles
- For thickness and length measurements



TECHNICAL DATA

| Order no. | Type | Measuring range | Application range | Measuring span | Size of measuring surface | Measuring span | Parallelism deviation | Measuring force | Mounting hole for indicator | Lifting lever | Indicating instrument (included in package) |
|-----------|-------------|-----------------|-------------------|----------------|---------------------------|----------------|-----------------------|-----------------|-----------------------------|---------------|---|
| 2051730 | EMD-300P-1D | 0-1" | 0-25.4 | 0.02 | 15.5 x 15.5 | mm | µm | N | inch | - | 2033119 Maxµm-III |
| 2051734 | EMD-300P-2D | 1-2" | 25.4-50.8 | 0.02 | 15.5 x 15.5 | mm | µm | N | inch | - | 2033119 Maxµm-III |
| 2051758 | EMD-300P-3D | 2-3" | 50.8-76.2 | 0.02 | 15.5 x 15.5 | mm | µm | N | inch | - | 2033119 Maxµm-III |
| 2051762 | EMD-300P-4D | 3-4" | 76.2-101.6 | 0.02 | 15.5 x 15.5 | mm | µm | N | inch | - | 2033119 Maxµm-III |
| 2051766 | EMD-300P-5D | 4-5" | 101.6-127 | 0.02 | 15.5 x 15.5 | mm | µm | N | inch | - | 2033119 Maxµm-III |
| 2051770 | EMD-300P-6D | 5-6" | 127-152.4 | 0.02 | 15.5 x 15.5 | mm | µm | N | inch | - | 2033119 Maxµm-III |
| 2051774 | EMD-300P-7D | 6-7" | 152.4-177.8 | 0.02 | 15.5 x 15.5 | mm | µm | N | inch | - | 2033119 Maxµm-III |
| 2051778 | EMD-300P-8D | 7-8" | 177.8-203.2 | 0.02 | 15.5 x 15.5 | mm | µm | N | inch | - | 2033119 Maxµm-III |
| 2051782 | EMD-300P-9D | 8-9" | 203.2-228.6 | 0.02 | 15.5 x 15.5 | mm | µm | N | inch | - | 2033119 Maxµm-III |

| Order no. | a | b | c | d | e |
|-----------|-------|-----|----|-----|-----|
| | mm | mm | mm | mm | mm |
| 2051730 | 25.4 | 150 | 29 | 145 | 158 |
| 2051734 | 50.8 | 175 | 29 | 141 | 154 |
| 2051758 | 76.2 | 200 | 29 | 155 | 167 |
| 2051762 | 101.6 | 226 | 29 | 167 | 180 |
| 2051766 | 127 | 251 | 29 | 180 | 193 |
| 2051770 | 152.4 | 278 | 30 | 203 | 215 |
| 2051774 | 177.8 | 303 | 30 | 213 | 226 |
| 2051778 | 203.2 | 329 | 30 | 231 | 244 |
| 2051782 | 228.6 | 335 | 30 | 248 | 261 |

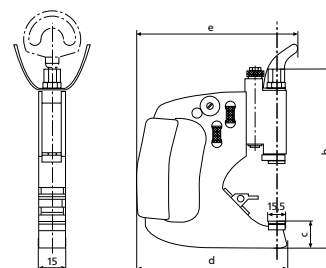

ACCESSORIES

| Order no. | Description | Type |
|-----------|--|---------|
| 2003150 | Base/bench stand for 300P or 1000P style snap gage | BA-26 |
| 2202272 | Plain anvil (lower), left (option) | AL-1755 |
| 2202273 | Plain anvil (upper), left (option) | AL-1756 |
| 2202274 | Plain anvil (lower), right (option) | AL-1757 |
| 2202275 | Plain anvil (lower), right (option) | AL-1758 |
| 2202276 | Plain anvil (lower), middle (option) | AL-1759 |
| 2202277 | Plain anvil (lower), middle (option) | AL-1760 |
| 2204644 | Bench stand for AGD style 3 disc masters up to 127 mm / 5" | BA-71 |
| 2232441 | Heavier force spring for EMD-30XP | SP-118 |
| 2232478 | Lighter force spring for EMD-30XP | SP-192 |
| 2243295 | Lighter force spring for EDI-30XP | 2243295 |
| 2243297 | Heavier force spring for EDI-30XP | 2243297 |

Marameter 300P-1 ... 300P-9

Indicating snap gage

FEATURES

- Patented "Channel Lock" design assures precise parallel anvil surfaces throughout the full 25 mm / 1" range of adjustment
- All 300P series snap gages are fully adjustable with positive position locking at any point within the range
- 0.50 mm / .020" movement of sensitive contact
- Snap gages available over a wide range of sizes, styles, and readout configurations
- Large 15.5 mm / .61" square tungsten carbide anvils provide flat, parallel, working surfaces ensuring precision that lasts
- Indicator can be rotated to read from front or rear of the gage
- All adjustments accomplished using a single hex wrench (included)
- **Package contains:** allen key

Applications:

- For rapid measurements of cylindrical parts such as shafts, bolts and spindles
- For thickness and length measurements



TECHNICAL DATA

| Order no. | Type | Measuring range | Applying range | Measuring span | Size of measuring surface | Measuring span | Parallelism deviation | Measuring force | Mounting hole for indicator | Lifting lever | Indicating instrument (included in package) |
|-----------|--------|-----------------|----------------|----------------|---------------------------|----------------|-----------------------|-----------------|-----------------------------|---------------|---|
| | | inch | mm | inch | mm | mm | µm | N | inch | | |
| 2050485 | 300P-1 | 0-1" | 0-25.4 | 0.02 | 15.5 x 15.5 | 0.5 | 4 | 18 | .375" | - | IDT-102 Indicator (12I) |
| 2050497 | 300P-2 | 1-2" | 25.4-50.8 | 0.02 | 15.5 x 15.5 | 0.5 | 4 | 18 | .375" | - | IDT-102 Indicator (12I) |
| 2050499 | 300P-3 | 2-3" | 50.8-76.2 | 0.02 | 15.5 x 15.5 | 0.5 | 4 | 18 | .375" | - | IDT-102 Indicator (12I) |
| 2050511 | 300P-4 | 3-4" | 76.2-101.6 | 0.02 | 15.5 x 15.5 | 0.5 | 4 | 18 | .375" | - | IDT-102 Indicator (12I) |
| 2050514 | 300P-5 | 4-5" | 101.6-127 | 0.02 | 15.5 x 15.5 | 0.5 | 4 | 18 | .375" | - | IDT-102 Indicator (12I) |
| 2050516 | 300P-6 | 5-6" | 127-152.4 | 0.02 | 15.5 x 15.5 | 0.5 | 4 | 18 | .375" | - | IDT-106 Indicator (22I) |
| 2050518 | 300P-7 | 6-7" | 152.4-177.8 | 0.02 | 15.5 x 15.5 | 0.5 | 4 | 18 | .375" | - | IDT-106 Indicator (22I) |
| 2050527 | 300P-8 | 7-8" | 177.8-203.2 | 0.02 | 15.5 x 15.5 | 0.5 | 4 | 18 | .375" | - | IDT-106 Indicator (22I) |
| 2050529 | 300P-9 | 8-9" | 203.2-228.6 | 0.02 | 15.5 x 15.5 | 0.5 | 4 | 18 | .375" | - | IDT-106 Indicator (22I) |

| Order no. | a | b | c | d | e |
|-----------|-------|-----|----|-----|-----|
| | mm | mm | mm | mm | mm |
| 2050485 | 25.4 | 150 | 29 | 145 | 158 |
| 2050497 | 50.8 | 175 | 29 | 141 | 154 |
| 2050499 | 76.2 | 200 | 29 | 155 | 167 |
| 2050511 | 101.6 | 226 | 29 | 167 | 180 |
| 2050514 | 127 | 251 | 29 | 180 | 193 |
| 2050516 | 152.4 | 278 | 30 | 203 | 215 |
| 2050518 | 177.8 | 303 | 30 | 213 | 226 |
| 2050527 | 203.2 | 329 | 30 | 231 | 244 |
| 2050529 | 228.6 | 335 | 30 | 248 | 261 |

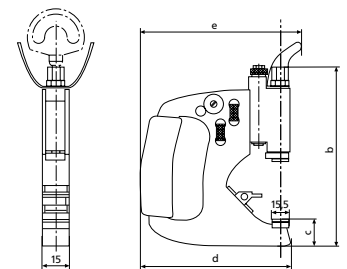

ACCESSORIES

| Order no. | Description | Type |
|-----------|--|---------|
| 2003150 | Base/bench stand for 300P or 1000P style snap gage | BA-26 |
| 2202272 | Plain anvil (lower), left (option) | AL-1755 |
| 2202273 | Plain anvil (upper), left (option) | AL-1756 |
| 2202274 | Plain anvil (lower), right (option) | AL-1757 |
| 2202275 | Plain anvil (lower), right (option) | AL-1758 |
| 2202276 | Plain anvil (lower), middle (option) | AL-1759 |
| 2202277 | Plain anvil (lower), middle (option) | AL-1760 |
| 2204644 | Bench stand for AGD style 3 disc masters up to 127 mm / 5" | BA-71 |
| 2232441 | Heavier force spring for EMD-30XP | SP-118 |
| 2232478 | Lighter force spring for EMD-30XP | SP-192 |

Marameter 300P-1M ... 300P-7M

Indicating snap gage

FEATURES

- Patented "Channel Lock" design assures precise parallel anvil surfaces throughout the full 25 mm / 1" range of adjustment
- All 300P series snap gages are fully adjustable with positive position locking at any point within the range
- 0.50 mm / .020" movement of sensitive contact
- Snap gages available over a wide range of sizes, styles, and readout configurations
- Large 15.5 mm / .61" square tungsten carbide anvils provide flat, parallel, working surfaces ensuring precision that lasts
- Indicator can be rotated to read from front or rear of the gage
- All adjustments accomplished using a single hex wrench (included)
- **Package contains:** allen key

Applications:

- For rapid measurements of cylindrical parts such as shafts, bolts and spindles
- For thickness and length measurements



TECHNICAL DATA

| Order no. | Type | Appli- cation range | Mea- suring span | Size of measuring surface | Mea- suring span | Paralle- lism de- viation | Mea- suring force | Mounting hole for indicator | Lifting lever | Indicating instrument (included in package) |
|-----------|---------|---------------------------|------------------------|---------------------------------|------------------------|---------------------------------|-------------------------|-----------------------------------|------------------|--|
| | | mm | inch | mm | mm | µm | N | inch | | |
| 2050496 | 300P-1M | 0 -25.4 | 0.02 | 15.5 x 15.5 | 0.5 | 4 | 18 | .375" | - | IDS-206 |
| 2050498 | 300P-2M | 25.4 -50.8 | 0.02 | 15.5 x 15.5 | 0.5 | 4 | 18 | .375" | - | IDS-206 |
| 2050510 | 300P-3M | 50.8 -76.2 | 0.02 | 15.5 x 15.5 | 0.5 | 4 | 18 | .375" | - | IDS-206 |
| 2050513 | 300P-4M | 76.2 -101.6 | 0.02 | 15.5 x 15.5 | 0.5 | 4 | 18 | .375" | - | IDS-206 |
| 2050515 | 300P-5M | 101.6 -127 | 0.02 | 15.5 x 15.5 | 0.5 | 4 | 18 | .375" | - | IDS-206 |
| 2050517 | 300P-6M | 127 -152.4 | 0.02 | 15.5 x 15.5 | 0.5 | 4 | 18 | .375" | - | IDS-206 |
| 2050526 | 300P-7M | 152.4 -177.8 | 0.02 | 15.5 x 15.5 | 0.5 | 4 | 18 | .375" | - | IDS-208 |

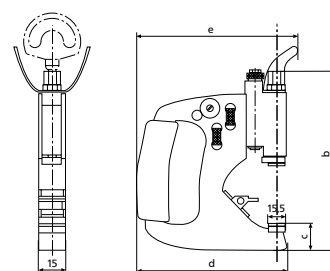

ACCESSORIES

| Order no. | Description | Type |
|-----------|--|---------|
| 2003150 | Base/bench stand for 300P or 1000P style snap gage | BA-26 |
| 2202272 | Plain anvil (lower), left (option) | AL-1755 |
| 2202273 | Plain anvil (upper), left (option) | AL-1756 |
| 2202274 | Plain anvil (lower), right (option) | AL-1757 |
| 2202275 | Plain anvil (lower), right (option) | AL-1758 |
| 2202276 | Plain anvil (lower), middle (option) | AL-1759 |
| 2202277 | Plain anvil (lower), middle (option) | AL-1760 |
| 2204644 | Bench stand for AGD style 3 disc masters up to 127 mm / 5" | BA-71 |
| 2232441 | Heavier force spring for EMD-30XP | SP-118 |
| 2232478 | Lighter force spring for EMD-30XP | SP-192 |

Marameter M-300P-1 ... M-300P-9

Indicating snap gage

FEATURES

- Patented "Channel Lock" design assures precise parallel anvil surfaces throughout the full 25 mm / 1" range of adjustment
- All 300P series snap gages are fully adjustable with positive position locking at any point within the range
- 0.50 mm / .020" movement of sensitive contact
- Snap gages available over a wide range of sizes, styles, and readout configurations
- Large 15.5 mm / .61" square tungsten carbide anvils provide flat, parallel, working surfaces ensuring precision that lasts
- Indicator can be rotated to read from front or rear of the gage
- All adjustments accomplished using a single hex wrench (included)
- **Package contains:** allen key

Applications:

- For rapid measurements of cylindrical parts such as shafts, bolts and spindles
- For thickness and length measurements



TECHNICAL DATA

| Order no. | Type | Measuring range | Application range | Measuring span | Size of measuring surface | Measuring span | Parallelism deviation | Measuring force | Lifting lever | Indicating instrument (included in package) |
|-----------|----------|-----------------|-------------------|----------------|---------------------------|----------------|-----------------------|-----------------|---------------|---|
| 2003100 | M-300P-1 | 0-1" | 0-25.4 | 0.02 | 15.5 x 15.5 | 0.5 | 4 | 18 | 8 | NONE |
| 2003101 | M-300P-2 | 1-2" | 25.4-50.8 | 0.02 | 15.5 x 15.5 | 0.5 | 4 | 18 | 8 | NONE |
| 2003102 | M-300P-3 | 2-3" | 50.8-76.2 | 0.02 | 15.5 x 15.5 | 0.5 | 4 | 18 | 8 | NONE |
| 2003103 | M-300P-4 | 3-4" | 76.2-101.6 | 0.02 | 15.5 x 15.5 | 0.5 | 4 | 18 | 8 | NONE |
| 2003104 | M-300P-5 | 4-5" | 101.6-127 | 0.02 | 15.5 x 15.5 | 0.5 | 4 | 18 | 8 | NONE |
| 2003105 | M-300P-6 | 5-6" | 127-152.4 | 0.02 | 15.5 x 15.5 | 0.5 | 4 | 18 | 8 | NONE |
| 2003106 | M-300P-7 | 6-7" | 152.4-177.8 | 0.02 | 15.5 x 15.5 | 0.5 | 4 | 18 | 8 | NONE |
| 2003107 | M-300P-8 | 7-8" | 177.8-203.2 | 0.02 | 15.5 x 15.5 | 0.5 | 4 | 18 | 8 | NONE |
| 2003108 | M-300P-9 | 8-9" | 203.2-228.6 | 0.02 | 15.5 x 15.5 | 0.5 | 4 | 18 | 8 | NONE |

| Order no. | b | c | d | e |
|-----------|-----|----|-----|-----|
| | mm | mm | mm | mm |
| 2003100 | 150 | 29 | 145 | 158 |
| 2003101 | 175 | 29 | 141 | 154 |
| 2003102 | 200 | 29 | 155 | 167 |
| 2003103 | 226 | 29 | 167 | 180 |
| 2003104 | 251 | 29 | 180 | 193 |
| 2003105 | 278 | 30 | 203 | 215 |
| 2003106 | 303 | 30 | 213 | 226 |
| 2003107 | 329 | 30 | 231 | 244 |
| 2003108 | 335 | 30 | 248 | 261 |

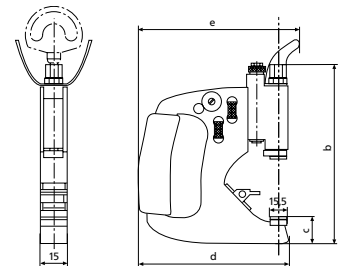

ACCESSORIES

| Order no. | Description | Type |
|-----------|--|---------|
| 2003150 | Base/bench stand for 300P or 1000P style snap gage | BA-26 |
| 2202272 | Plain anvil (lower), left (option) | AL-1755 |
| 2202273 | Plain anvil (upper), left (option) | AL-1756 |
| 2202274 | Plain anvil (lower), right (option) | AL-1757 |
| 2202275 | Plain anvil (lower), right (option) | AL-1758 |
| 2202276 | Plain anvil (lower), middle (option) | AL-1759 |
| 2202277 | Plain anvil (lower), middle (option) | AL-1760 |
| 2204644 | Bench stand for AGD style 3 disc masters up to 127 mm / 5" | BA-71 |
| 2232441 | Heavier force spring for EMD-30XP | SP-118 |
| 2232478 | Lighter force spring for EMD-30XP | SP-192 |
| 4332000 | Millimess 0.01, ± 0.25 mm | 1010 |
| 4333000 | Millimess 5 µm, ± 130 µm | 1004 |
| 4337620 | Digital indicator, 0.0005 mm, 12.5 mm | 1086 R |
| 4337624 | Digital indicator, 0.0005 mm, 12.5 mm | 1086 Ri |



1004



1086
R-HR;1086
R;1086 ZR

Marameter OMI-300P-1 ... OMI-300P-9

Indicating snap gage

FEATURES

- Patented "Channel Lock" design assures precise parallel anvil surfaces throughout the full 25 mm / 1" range of adjustment
- All 300P series snap gages are fully adjustable with positive position locking at any point within the range
- 0.50 mm / .020" movement of sensitive contact
- Snap gages available over a wide range of sizes, styles, and readout configurations
- Large 15.5 mm / .61" square tungsten carbide anvils provide flat, parallel, working surfaces ensuring precision that lasts
- Indicator can be rotated to read from front or rear of the gage
- All adjustments accomplished using a single hex wrench (included)
- **Package contains:** allen key

Applications:

- For rapid measurements of cylindrical parts such as shafts, bolts and spindles
- For thickness and length measurements



TECHNICAL DATA

| Order no. | Type | Measuring range | Application range | Measuring span | Size of measuring surface | Measuring span | Parallelism deviation | Measuring force | Mounting hole for indicator | Lifting lever | Indicating instrument (included in package) |
|-----------|------------|-----------------|-------------------|----------------|---------------------------|----------------|-----------------------|-----------------|-----------------------------|---------------|---|
| 2054281 | OMI-300P-1 | 0 - 1" | 0 - 25.4 | 0.02 | 15.5 x 15.5 | mm | 4 | 18 | .375" | - | NONE |
| 2054287 | OMI-300P-2 | 1 - 2" | 25.4 - 50.8 | 0.02 | 15.5 x 15.5 | mm | 4 | 18 | .375" | - | NONE |
| 2054288 | OMI-300P-3 | 2 - 3" | 50.8 - 76.2 | 0.02 | 15.5 x 15.5 | mm | 4 | 18 | .375" | - | NONE |
| 2054294 | OMI-300P-4 | 3 - 4" | 76.2 - 101.6 | 0.02 | 15.5 x 15.5 | mm | 4 | 18 | .375" | - | NONE |
| 2054295 | OMI-300P-5 | 4 - 5" | 101.6 - 127 | 0.02 | 15.5 x 15.5 | mm | 4 | 18 | .375" | - | NONE |
| 2054296 | OMI-300P-6 | 5 - 6" | 127 - 152.4 | 0.02 | 15.5 x 15.5 | mm | 4 | 18 | .375" | - | NONE |
| 2054297 | OMI-300P-7 | 6 - 7" | 152.4 - 177.8 | 0.02 | 15.5 x 15.5 | mm | 4 | 18 | .375" | - | NONE |
| 2054298 | OMI-300P-8 | 7 - 8" | 177.8 - 203.2 | 0.02 | 15.5 x 15.5 | mm | 4 | 18 | .375" | - | NONE |
| 2054299 | OMI-300P-9 | 8 - 9" | 203.2 - 228.6 | 0.02 | 15.5 x 15.5 | mm | 4 | 18 | .375" | - | NONE |

| Order no. | a | b | c | d | e |
|-----------|-------|-----|----|-----|-----|
| | mm | mm | mm | mm | mm |
| 2054281 | 25.4 | 150 | 29 | 145 | 158 |
| 2054287 | 50.8 | 175 | 29 | 141 | 154 |
| 2054288 | 76.2 | 200 | 29 | 155 | 167 |
| 2054294 | 101.6 | 226 | 29 | 167 | 180 |
| 2054295 | 127 | 251 | 29 | 180 | 193 |
| 2054296 | 152.4 | 278 | 30 | 203 | 215 |
| 2054297 | 177.8 | 303 | 30 | 213 | 226 |
| 2054298 | 203.2 | 329 | 30 | 231 | 244 |
| 2054299 | 228.6 | 335 | 30 | 248 | 261 |

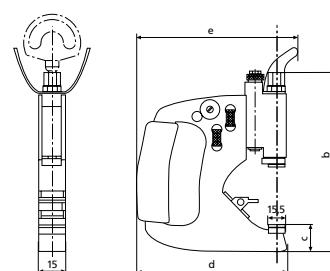

ACCESSORIES

| Order no. | Description | Type |
|-----------|--|---------|
| 2003150 | Base/bench stand for 300P or 1000P style snap gage | BA-26 |
| 2202272 | Plain anvil (lower), left (option) | AL-1755 |
| 2202273 | Plain anvil (upper), left (option) | AL-1756 |
| 2202274 | Plain anvil (lower), right (option) | AL-1757 |
| 2202275 | Plain anvil (lower), right (option) | AL-1758 |
| 2202276 | Plain anvil (lower), middle (option) | AL-1759 |
| 2202277 | Plain anvil (lower), middle (option) | AL-1760 |
| 2204644 | Bench stand for AGD style 3 disc masters up to 127 mm / 5" | BA-71 |
| 2232441 | Heavier force spring for EMD-30XP | SP-118 |
| 2232478 | Lighter force spring for EMD-30XP | SP-192 |

Marameter EDI-301P-1 ... EDI-301P-9

Indicating snap gage

FEATURES

- Patented "Channel Lock" design assures precise parallel anvil surfaces throughout the full 25 mm / 1" range of adjustment
- All 300P series snap gages are fully adjustable with positive position locking at any point within the range
- 0.50 mm / .020" movement of sensitive contact
- Snap gages available over a wide range of sizes, styles, and readout configurations
- Large 15.5 mm / .61" square tungsten carbide anvils provide flat, parallel, working surfaces that ensure lasting precision that lasts
- Indicator can be rotated to read from front or rear of the gage
- All adjustments accomplished using a single hex wrench (included)
- **Package contains:** allen key

Applications:

- For rapid measurements of cylindrical parts such as shafts, bolts and spindles
- For thickness and length measurements



TECHNICAL DATA

| Order no. | Type | Measuring range | Application range | Measuring span | Size of measuring surface | Measuring span | Parallelism deviation | Measuring force | Mounting hole for indicator | Lifting lever | Indicating instrument (included in package) |
|-----------|------------|-----------------|-------------------|----------------|---------------------------|----------------|-----------------------|-----------------|-----------------------------|---------------|---|
| 2051674 | EDI-301P-1 | 0-1" | 0-25.4 | 0.02 | 15.5 x 15.5 | 0.5 | 4 | 18 | .375" | • | 2034201 uMaxumll indicator |
| 2051680 | EDI-301P-2 | 1-2" | 25.4-50.8 | 0.02 | 15.5 x 15.5 | 0.5 | 4 | 18 | .375" | • | 2034201 uMaxumll indicator |
| 2051681 | EDI-301P-3 | 2-3" | 50.8-76.2 | 0.02 | 15.5 x 15.5 | 0.5 | 4 | 18 | .375" | • | 2034201 uMaxumll indicator |
| 2051687 | EDI-301P-4 | 3-4" | 76.2-101.6 | 0.02 | 15.5 x 15.5 | 0.5 | 4 | 18 | .375" | • | 2034201 uMaxumll indicator |
| 2051688 | EDI-301P-5 | 4-5" | 101.6-127 | 0.02 | 15.5 x 15.5 | 0.5 | 4 | 18 | .375" | • | 2034201 uMaxumll indicator |
| 2051689 | EDI-301P-6 | 5-6" | 127-152.4 | 0.02 | 15.5 x 15.5 | 0.5 | 4 | 18 | .375" | • | 2034201 uMaxumll indicator |
| 2051690 | EDI-301P-7 | 6-7" | 152.4-177.8 | 0.02 | 15.5 x 15.5 | 0.5 | 4 | 18 | .375" | • | 2034201 uMaxumll indicator |
| 2051691 | EDI-301P-8 | 7-8" | 177.8-203.2 | 0.02 | 15.5 x 15.5 | 0.5 | 4 | 18 | .375" | • | 2034201 uMaxumll indicator |
| 2051692 | EDI-301P-9 | 8-9" | 203.2-228.6 | 0.02 | 15.5 x 15.5 | 0.5 | 4 | 18 | .375" | • | 2034201 uMaxumll indicator |

| Order no. | a | b | c | d | e |
|-----------|-------|-----|----|-----|-----|
| | mm | mm | mm | mm | mm |
| 2051674 | 25.4 | 150 | 29 | 145 | 158 |
| 2051680 | 50.8 | 175 | 29 | 141 | 154 |
| 2051681 | 76.2 | 200 | 29 | 155 | 167 |
| 2051687 | 101.6 | 226 | 29 | 167 | 180 |
| 2051688 | 127 | 251 | 29 | 180 | 193 |
| 2051689 | 152.4 | 278 | 30 | 203 | 215 |
| 2051690 | 177.8 | 303 | 30 | 213 | 226 |
| 2051691 | 203.2 | 329 | 30 | 231 | 244 |
| 2051692 | 228.6 | 335 | 30 | 248 | 261 |

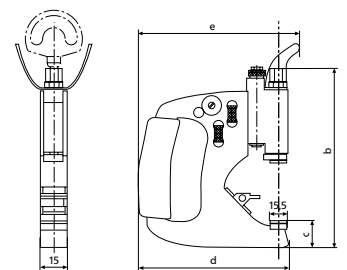

1004



1086 R-HR;
1086 R;1086 ZR

ACCESSORIES

| Order no. | Description | Type |
|-----------|---------------------------------------|---------|
| 4332000 | Millimess 0.01, ± 0.25 mm | 1010 |
| 4333000 | Millimess 5 µm, ± 130 µm | 1004 |
| 4337620 | Digital indicator, 0.0005 mm, 12.5 mm | 1086 R |
| 4337624 | Digital indicator, 0.0005 mm, 12.5 mm | 1086 Ri |

Marameter EMD-301P-1D ... EMD-301P-9D

Indicating snap gage



FEATURES

- Patented "Channel Lock" design assures precise parallel anvil surfaces throughout the full 25 mm / 1" range of adjustment
- All 300P series snap gages are fully adjustable with positive position locking at any point within the range
- 0.50 mm / .020" movement of sensitive contact
- Snap gages available over a wide range of sizes, styles, and readout configurations
- Large 15.5 mm / .61" square tungsten carbide anvils provide flat, parallel, working surfaces that ensure lasting precision that lasts
- Indicator can be rotated to read from front or rear of the gage
- All adjustments accomplished using a single hex wrench (included)
- **Data interface:** Digimatic, RS-232C, USB
- **Energy supply:** battery operation
- **Package contains:** allen key

Applications:

- For rapid measurements of cylindrical parts such as shafts, bolts and spindles
- For thickness and length measurements



TECHNICAL DATA

| Order no. | Type | Measuring range | Application range | Measuring span | Size of measuring surface | Measuring span | Parallelism deviation | Measuring force | Mounting hole for indicator | Lifting lever | Indicating instrument (included in package) |
|-----------|-------------|-----------------|-------------------|----------------|---------------------------|----------------|-----------------------|-----------------|-----------------------------|---------------|---|
| | | inch | mm | inch | mm | mm | µm | N | inch | | |
| 2051806 | EMD-301P-1D | 0 - 1" | 0 - 25.4 | 0.02 | 15.5 x 15.5 | 0.5 | 4 | 18 | .375" | • | 2033119 MaxumIII |
| 2051810 | EMD-301P-2D | 1 - 2" | 25.4 - 50.8 | 0.02 | 15.5 x 15.5 | 0.5 | 4 | 18 | .375" | • | 2033119 MaxumIII |
| 2051834 | EMD-301P-3D | 2 - 3" | 50.8 - 76.2 | 0.02 | 15.5 x 15.5 | 0.5 | 4 | 18 | .375" | • | 2033119 MaxumIII |
| 2051838 | EMD-301P-4D | 3 - 4" | 76.2 - 101.6 | 0.02 | 15.5 x 15.5 | 0.5 | 4 | 18 | .375" | • | 2033119 MaxumIII |
| 2051842 | EMD-301P-5D | 4 - 5" | 101.6 - 127 | 0.02 | 15.5 x 15.5 | 0.5 | 4 | 18 | .375" | • | 2033119 MaxumIII |
| 2051846 | EMD-301P-6D | 5 - 6" | 127 - 152.4 | 0.02 | 15.5 x 15.5 | 0.5 | 4 | 18 | .375" | • | 2033119 MaxumIII |
| 2051850 | EMD-301P-7D | 6 - 7" | 152.4 - 177.8 | 0.02 | 15.5 x 15.5 | 0.5 | 4 | 18 | .375" | • | 2033119 MaxumIII |
| 2051854 | EMD-301P-8D | 7 - 8" | 177.8 - 203.2 | 0.02 | 15.5 x 15.5 | 0.5 | 4 | 18 | .375" | • | 2033119 MaxumIII |
| 2051858 | EMD-301P-9D | 8 - 9" | 203.2 - 228.6 | 0.02 | 15.5 x 15.5 | 0.5 | 4 | 18 | .375" | • | 2033119 MaxumIII |

| Order no. | a | b | c | d | e |
|-----------|-------|-----|----|-----|-----|
| | mm | mm | mm | mm | mm |
| 2051806 | 25.4 | 150 | 29 | 145 | 158 |
| 2051810 | 50.8 | 175 | 29 | 141 | 154 |
| 2051834 | 76.2 | 200 | 29 | 155 | 167 |
| 2051838 | 101.6 | 226 | 29 | 167 | 180 |
| 2051842 | 127 | 251 | 29 | 180 | 193 |
| 2051846 | 152.4 | 278 | 30 | 203 | 215 |
| 2051850 | 177.8 | 303 | 30 | 213 | 226 |
| 2051854 | 203.2 | 329 | 30 | 231 | 244 |
| 2051858 | 228.6 | 335 | 30 | 248 | 261 |

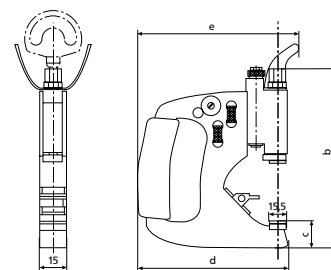

1004



1086 R-HR;
1086 R; 1086 ZR

ACCESSORIES

| Order no. | Description | Type |
|-----------|---------------------------------------|---------|
| 4332000 | Millimess 0.01, ± 0.25 mm | 1010 |
| 4333000 | Millimess 5 µm, ± 130 µm | 1004 |
| 4337620 | Digital indicator, 0.0005 mm, 12.5 mm | 1086 R |
| 4337624 | Digital indicator, 0.0005 mm, 12.5 mm | 1086 Ri |

Marameter OMI-301P-1 ... OMI-301P-9

Indicating snap gage

FEATURES

- Patented "Channel Lock" design assures precise parallel anvil surfaces throughout the full 25 mm / 1" range of adjustment
- All 300P series snap gages are fully adjustable with positive position locking at any point within the range
- 0.50 mm / .020" movement of sensitive contact
- Snap gages available over a wide range of sizes, styles, and readout configurations
- Large 15.5 mm / .61" square tungsten carbide anvils provide flat, parallel, working surfaces that ensure lasting precision that lasts
- Indicator can be rotated to read from front or rear of the gage
- All adjustments accomplished using a single hex wrench (included)
- **Package contains:** allen key

Applications:

- For rapid measurements of cylindrical parts such as shafts, bolts and spindles
- For thickness and length measurements



TECHNICAL DATA

| Order no. | Type | Measuring range | Appl. range | Measuring span | Size of measuring surface | Measuring span | Parallelism deviation | Measuring force | Mounting hole for indicator | Lifting lever | Indicating instrument (included in package) |
|-----------|------------|-----------------|--------------|----------------|---------------------------|----------------|-----------------------|-----------------|-----------------------------|---------------|---|
| 2054300 | OMI-301P-1 | 0 - 1" | 0 -25.4 | 0.02 | 15.5 x 15.5 | 0.5 | 4 | 18 | .375" | • | NONE |
| 2054306 | OMI-301P-2 | 1 - 2" | 25.4 -50.8 | 0.02 | 15.5 x 15.5 | 0.5 | 4 | 18 | .375" | • | NONE |
| 2054307 | OMI-301P-3 | 2 - 3" | 50.8 -76.2 | 0.02 | 15.5 x 15.5 | 0.5 | 4 | 18 | .375" | • | NONE |
| 2054313 | OMI-301P-4 | 3 - 4" | 76.2 -101.6 | 0.02 | 15.5 x 15.5 | 0.5 | 4 | 18 | .375" | • | NONE |
| 2054314 | OMI-301P-5 | 4 - 5" | 101.6 -127 | 0.02 | 15.5 x 15.5 | 0.5 | 4 | 18 | .375" | • | NONE |
| 2054315 | OMI-301P-6 | 5 - 6" | 127 -152.4 | 0.02 | 15.5 x 15.5 | 0.5 | 4 | 18 | .375" | • | NONE |
| 2054316 | OMI-301P-7 | 6 - 7" | 152.4 -177.8 | 0.02 | 15.5 x 15.5 | 0.5 | 4 | 18 | .375" | • | NONE |
| 2054317 | OMI-301P-8 | 7 - 8" | 177.8 -203.2 | 0.02 | 15.5 x 15.5 | 0.5 | 4 | 18 | .375" | • | NONE |
| 2054318 | OMI-301P-9 | 8 - 9" | 203.2 -228.6 | 0.02 | 15.5 x 15.5 | 0.5 | 4 | 18 | .375" | • | NONE |

| Order no. | a | b | c | d | e |
|-----------|-------|-----|----|-----|-----|
| 2054300 | 25.4 | 150 | 29 | 145 | 158 |
| 2054306 | 50.8 | 175 | 29 | 141 | 154 |
| 2054307 | 76.2 | 200 | 29 | 155 | 167 |
| 2054313 | 101.6 | 226 | 29 | 167 | 180 |
| 2054314 | 127 | 251 | 29 | 180 | 193 |
| 2054315 | 152.4 | 278 | 30 | 203 | 215 |
| 2054316 | 177.8 | 303 | 30 | 213 | 226 |
| 2054317 | 203.2 | 329 | 30 | 231 | 244 |
| 2054318 | 228.6 | 335 | 30 | 248 | 261 |

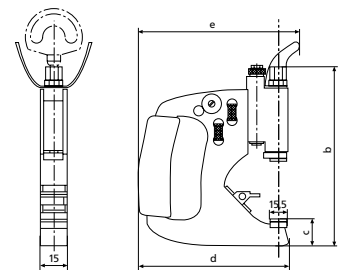

1004



1086 R-HR;
1086 R;1086 ZR

ACCESSORIES

| Order no. | Description | Type |
|-----------|---------------------------------------|---------|
| 4332000 | Millimess 0.01, ± 0.25 mm | 1010 |
| 4333000 | Millimess 5 µm, ± 130 µm | 1004 |
| 4337620 | Digital indicator, 0.0005 mm, 12.5 mm | 1086 R |
| 4337624 | Digital indicator, 0.0005 mm, 12.5 mm | 1086 Ri |

Marameter 301P-1 ... 301P-9

Indicating snap gage

FEATURES

- Patented "Channel Lock" design assures precise parallel anvil surfaces throughout the full 25 mm / 1" range of adjustment
- All 300P series snap gages are fully adjustable with positive position locking at any point within the range
- 0.50 mm / .020" movement of sensitive contact
- Snap gages available over a wide range of sizes, styles, and readout configurations
- Large 15.5 mm / .61" square tungsten carbide anvils provide flat, parallel, working surfaces that ensure lasting precision that lasts
- Indicator can be rotated to read from front or rear of the gage
- All adjustments accomplished using a single hex wrench (included)
- Package contains: allen key

Applications:

- For rapid measurements of cylindrical parts such as shafts, bolts and spindles
- For thickness and length measurements



TECHNICAL DATA

| Order no. | Type | Measuring range | Appl. range | Measuring span | Size of measuring surface | Measuring span | Parallelism deviation | Measuring force | Moun-ting hole for indicator | Lifting lever | Indicating instrument (included in package) |
|-----------|--------|-----------------|-------------|----------------|---------------------------|----------------|-----------------------|-----------------|------------------------------|---------------|---|
| 2050562 | 301P-1 | 0-1" | 0-25.4 | 0.02 | 15.5 x 15.5 | mm | 4 | 18 | .375" | • | IDT-102 Indicator (12l) |
| 2050574 | 301P-2 | 1-2" | 25.4-50.8 | 0.02 | 15.5 x 15.5 | mm | 4 | 18 | .375" | • | IDT-102 Indicator (12l) |
| 2050576 | 301P-3 | 2-3" | 50.8-76.2 | 0.02 | 15.5 x 15.5 | mm | 4 | 18 | .375" | • | IDT-102 Indicator (12l) |
| 2050588 | 301P-4 | 3-4" | 76.2-101.6 | 0.02 | 15.5 x 15.5 | mm | 4 | 18 | .375" | • | IDT-102 Indicator (12l) |
| 2050590 | 301P-5 | 4-5" | 101.6-127 | 0.02 | 15.5 x 15.5 | mm | 4 | 18 | .375" | • | IDT-102 Indicator (12l) |
| 2050592 | 301P-6 | 5-6" | 127-152.4 | 0.02 | 15.5 x 15.5 | mm | 4 | 18 | .375" | • | IDT-102 Indicator (12l) |
| 2050594 | 301P-7 | 6-7" | 152.4-177.8 | 0.02 | 15.5 x 15.5 | mm | 4 | 18 | .375" | • | IDT-102 Indicator (12l) |
| 2050596 | 301P-8 | 7-8" | 177.8-203.2 | 0.02 | 15.5 x 15.5 | mm | 4 | 18 | .375" | • | IDT-102 Indicator (12l) |
| 2050598 | 301P-9 | 8-9" | 203.2-228.6 | 0.02 | 15.5 x 15.5 | mm | 4 | 18 | .375" | • | IDT-102 Indicator (12l) |

| Order no. | a | b | c | d | e |
|-----------|-------|-----|----|-----|-----|
| | mm | mm | mm | mm | mm |
| 2050562 | 25.4 | 150 | 29 | 145 | 158 |
| 2050574 | 50.8 | 175 | 29 | 141 | 154 |
| 2050576 | 76.2 | 200 | 29 | 155 | 167 |
| 2050588 | 101.6 | 226 | 29 | 167 | 180 |
| 2050590 | 127 | 251 | 29 | 180 | 193 |
| 2050592 | 152.4 | 278 | 30 | 203 | 215 |
| 2050594 | 177.8 | 303 | 30 | 213 | 226 |
| 2050596 | 203.2 | 329 | 30 | 231 | 244 |
| 2050598 | 228.6 | 335 | 30 | 248 | 261 |

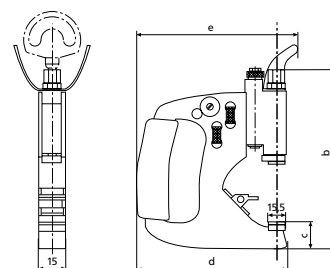

1004



1086 R-HR;
1086 R;1086 ZR

ACCESSORIES

| Order no. | Description | Type |
|-----------|---------------------------------------|---------|
| 4332000 | Millimess 0.01, ± 0.25 mm | 1010 |
| 4333000 | Millimess 5 µm, ± 130 µm | 1004 |
| 4337620 | Digital indicator, 0.0005 mm, 12.5 mm | 1086 R |
| 4337624 | Digital indicator, 0.0005 mm, 12.5 mm | 1086 Ri |

Marameter 301 P

Indicating snap gage

FEATURES

- Patented "Channel Lock" design assures precise parallel anvil surfaces throughout the full 25 mm / 1" range of adjustment
- All 300P series snap gages are fully adjustable with positive position locking at any point within the range
- 0.50 mm / .020" movement of sensitive contact
- Snap gages available over a wide range of sizes, styles, and readout configurations
- Large 15.5 mm / .61" square tungsten carbide anvils provide flat, parallel, working surfaces that ensure lasting precision that lasts
- Indicator can be rotated to read from front or rear of the gage
- All adjustments accomplished using a single hex wrench (included)
- **Package contains:** allen key

Applications:

- For rapid measurements of cylindrical parts such as shafts, bolts and spindles
- For thickness and length measurements



TECHNICAL DATA

| Order no. | Type | Appli- cation range | Size of measuring surface | Mea- suring span | Parallelism deviation | Mea- suring force | Mounting hole for indicator | Lifting lever | Indicating instrument (includ- ed in package) |
|-----------|-------|---------------------------|---------------------------------|------------------------|--------------------------|-------------------------|-----------------------------------|------------------|---|
| | | mm | mm | mm | µm | N | mm | | |
| 2003110 | 301 P | 0–25.4 | 15.5 x 15.5 | 0.5 | 4 | 18 | 8 | • | NONE |
| 2003111 | 301 P | 25.4 –50.8 | 15.5 x 15.5 | 0.5 | 4 | 18 | 8 | • | NONE |
| 2003112 | 301 P | 50.8 –76.2 | 15.5 x 15.5 | 0.5 | 4 | 18 | 8 | • | NONE |
| 2003113 | 301 P | 76.2 –101.6 | 15.5 x 15.5 | 0.5 | 4 | 18 | 8 | • | NONE |
| 2003114 | 301 P | 101.6 –127 | 15.5 x 15.5 | 0.5 | 4 | 18 | 8 | • | NONE |
| 2003115 | 301 P | 127 –152.4 | 15.5 x 15.5 | 0.5 | 4 | 18 | 8 | • | NONE |
| 2003116 | 301 P | 152.4 –177.8 | 15.5 x 15.5 | 0.5 | 4 | 18 | 8 | • | NONE |
| 2003117 | 301 P | 177.8 –203.2 | 15.5 x 15.5 | 0.5 | 4 | 18 | 8 | • | NONE |
| 2003118 | 301 P | 203.2 –228.6 | 15.5 x 15.5 | 0.5 | 4 | 18 | 8 | • | NONE |

| Order no. | b | c | d | e |
|-----------|-----|----|-----|-----|
| | mm | mm | mm | mm |
| 2003110 | 150 | 29 | 145 | 158 |
| 2003111 | 175 | 29 | 141 | 154 |
| 2003112 | 200 | 29 | 155 | 167 |
| 2003113 | 226 | 29 | 167 | 180 |
| 2003114 | 251 | 29 | 180 | 193 |
| 2003115 | 278 | 30 | 203 | 215 |
| 2003116 | 303 | 30 | 213 | 226 |
| 2003117 | 329 | 30 | 231 | 244 |
| 2003118 | 335 | 30 | 248 | 261 |

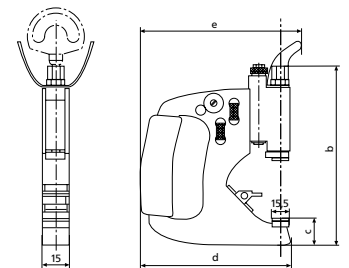

1004



1086 R-HR;
1086 R;1086 ZR

ACCESSORIES

| Order no. | Description | Type |
|-----------|---------------------------------------|---------|
| 4332000 | Millimess 0.01, ± 0.25 mm | 1010 |
| 4333000 | Millimess 5 µm, ± 130 µm | 1004 |
| 4337620 | Digital indicator, 0.0005 mm, 12.5 mm | 1086 R |
| 4337624 | Digital indicator, 0.0005 mm, 12.5 mm | 1086 Ri |

Marameter 852 TS / 852 TSZ

Indicating bench snap gage

FEATURES

- Rugged steel frame can be inclined up to 45° from the sturdy base
- Measuring spindle and anvil are made of hardened stainless steel with mounting bore for insertion of interchangeable anvils
- Height adjustable stop
- Anvil spindle can easily be fine adjusted
- Constant measuring force as a result of built-in spring, eliminating user influence
- **Package contains:** plan carbide anvils diameter 3.5 mm



Applications:

- Perfect ergonomic design as base can be inclined ensuring it is easy to read and the operator has free hands
- For rapid measurements of cylindrical parts (shafts, bolts and shanks)
- Thickness and length measurements
- For determining the pitch diameter of external threads (optionally with thread flank measuring anvils)
- For gears (optionally with sphere or roller measuring anvils)
- Particularly suited for exact series measurements

TECHNICAL DATA

| Order no. | 4510030 | 4510031 | 4510035 |
|---|---------------|-----------|-----------|
| Type | 852 TS | | 852 TSZ |
| Application range | mm | 0 – 80 | |
| Application range | inch | 0 – 3.15" | |
| Measuring span | mm | 1.2 | |
| Parallelism deviation | µm | 2 | |
| Flatness deviation | µm | 0.3 | |
| Measuring force | N | 7.5 | |
| Mounting hole for indicator | 8 mm | 8 mm | .375 inch |
| Indicating instrument (included in package) | Millimes 1003 | Without | Without |

ACCESSORIES

| Order no. | Description | Type |
|-----------|---------------------------------------|---------|
| 4333000 | Millimes 5 µm, ± 130 µm | 1004 |
| 4334000 | Millimes 1 µm, ± 50 µm | 1003 |
| 4334001 | Millimes 2 µm, ± 130 µm | 1003 XL |
| 4335000 | Millimes 0.5 µm, ± 25 µm | 1002 |
| 4337620 | Digital indicator, 0.0005 mm, 12.5 mm | 1086 R |
| 4337624 | Digital indicator, 0.0005 mm, 12.5 mm | 1086 Ri |



1004



1003



1002



1086 R

Marameter 852

Indicating thread snap gage

FEATURES

- Rugged, forged steel frame with heat insulators
- Measuring spindle is mounted in long guideway with lever controlled retraction
- Measuring spindle and anvil are made of hardened stainless steel with mounting bore for insertion of interchangeable anvils
- Adjustable center stop for automatic alignment
- Anvil spindle can easily be fine adjusted
- Constant measuring force as a result of built-in spring, eliminating user influence
- Maximum wear resistance due to noncontact positioning in conjunction with carbide tipped measuring faces
- **Package contains:** flat contact point 903 (steel), wooden case, excludes indicator



Applications:

- For measuring pitch, root and outside diameters of all kinds of external threads as well as serrations
- Universally applicable and extremely versatile; each instrument spans a broad measuring range

TECHNICAL DATA

| Order no. | | 4510000 | 4510001 | 4510002 | 4510003 |
|---------------------|---------------|---------|------------|------------|------------|
| Type | | 852 | | | |
| Application range | mm | 0–45 | 45–85 | 85–140 | 140–190 |
| Application range | inch | 0–1.77" | 1.77–3.34" | 3.34–5.51" | 5.51–7.48" |
| Measuring span | mm | 2 | 2.5 | | |
| Repeatability f_w | μm | 1 | | | |
| Measuring force | N | 7.5 | | 9 | |
| Frame size | | 2 | 3 | 4 | 5 |

| Order no. | a | b | c | e | f | g | h | k | l |
|-----------|----|-----|-----|----|-----|----|----|----|-----|
| | mm | mm | mm | mm | mm | mm | mm | mm | mm |
| 4510000 | 13 | 140 | 68 | 60 | 77 | 13 | 13 | 25 | 34 |
| 4510001 | 8 | 193 | 11 | 60 | 103 | 14 | 13 | 28 | 59 |
| 4510002 | 10 | 258 | 162 | 70 | 141 | 16 | 12 | 31 | 87 |
| 4510003 | 6 | 316 | 212 | 75 | 171 | 16 | 12 | 31 | 112 |

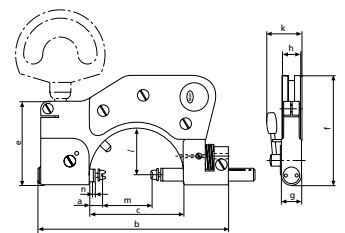

ACCESSORIES

| Order no. | Description | Type |
|-----------|--|----------|
| 4333000 | Millimess 5 μm , $\pm 130 \mu\text{m}$ | 1004 |
| 4334000 | Millimess 1 μm , $\pm 50 \mu\text{m}$ | 1003 |
| 4334001 | Millimess 2 μm , $\pm 130 \mu\text{m}$ | 1003 XL |
| 4335000 | Millimess 0.5 μm , $\pm 25 \mu\text{m}$ | 1002 |
| 4337620 | Digital indicator, 0.0005 mm, 12.5 mm | 1086 R |
| 4337624 | Digital indicator, 0.0005 mm, 12.5 mm | 1086 Ri |
| 4450051 | Holder, frame size 2 | 840 Fk/2 |
| 4450020 | Base for stationary application | 840 Ff |
| 4173210 | Anvil flat, hardened steel, $\varnothing 7.5 \text{ mm}$ | 40 Za |
| 4511190 | Anvil flat, carbide tipped, $\varnothing 7.5 \text{ mm}$ | 40 Za |
| 4450052 | Holder, frame size 3 | 840 Fk/3 |
| 4450053 | Holder, frame size 4 + 5 | 840 Fk/4 |



1004



1003



1002



1086 R



840 Fk/2

Marameter thread anvils

Indicating thread snap gage

FEATURES

- For pitch diameters
- Wear-resistant special steel, hardened
- With cylindrical mounting shank and retainer ring for rotatable mounting in the bore of the dial comparator snap gage
- Pair comprises V-anvil and cone
- With a pitch of 0.2 –0.45 mm, the V-anvil bridges 3 turns
 - It should therefore be set with 715 E thread adjustment pins, otherwise with 43 Z setting standards

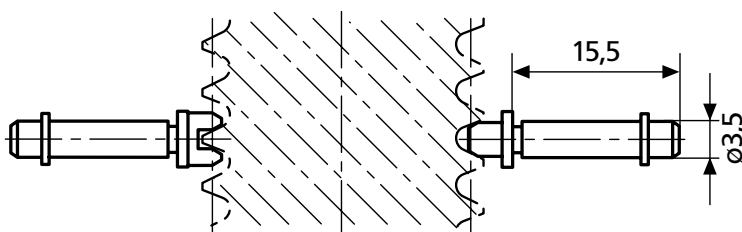

ACCESSORIES

| Thread pitch | Blade Order no. | V-anvil Order no. |
|--|--------------------|----------------------|
| Pitch diameter, external thread | | |
| Metric 60° | | |
| 0.2 | 4173007 | 4173707 |
| 0.25 | 4173008 | 4173708 |
| 0.3 | 4173009 | 4173709 |
| 0.35 | 4173010 | 4173710 |
| 0.4 | 4173011 | 4173711 |
| 0.45 | 4173012 | 4173712 |
| 0.5 –0.7 | 4173000 | 4173700 |
| 0.7 –1 | 4173001 | 4173701 |
| 1.25 –2 | 4173002 | 4173702 |
| 2 –3.5 | 4173003 | 4173703 |
| 3.5 –5 | 4173004 | 4173704 |
| 5 –7 | 4173005 | 4173705 |
| 7 –9 | 4173006 | 4173706 |

| Thread pitch in TPI | Blade Order no. | V-anvil Order no. |
|----------------------|--------------------|----------------------|
| UST 60° | | |
| 10 –7 | 4173120 | 4173820 |
| 14 –10 | 4173119 | 4173819 |
| 18 –14 | 4173118 | 4173818 |
| 24 –18 | 4173117 | 4173817 |
| 32 –24 | 4173116 | 4173816 |
| 4.5 –3 | 4173122 | 4173822 |
| 40 –32 | 4173115 | 4173815 |
| 48 –40 | 4173114 | 4173814 |
| 7 –4.5 | 4173121 | 4173821 |
| Whitworth 55° | | |
| 10 –7 | 4173048 | 4173748 |
| 14 –10 | 4173047 | 4173747 |
| 18 –14 | 4173046 | 4173746 |
| 24 –18 | 4173045 | 4173745 |
| 3 –2.5 | 4179408 | 4179410 |
| 32 –24 | 4173044 | 4173744 |
| 4.5 –3 | 4173050 | 4173750 |
| 40 –32 | 4173043 | 4173743 |
| 7 –4.5 | 4173049 | 4173749 |

Marameter

Ball contact

FEATURES

- For gear measurement and for special tasks
- Carbide measuring balls
- Cylindrical mounting shank with circlip for mounting in the mounting bore of the micrometer or indicating snap gage

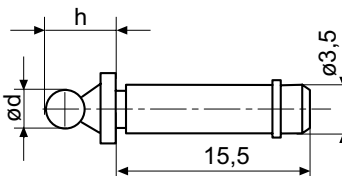

| Order no. | d mm | h mm | Measuring surface |
|-----------|---------|---------|----------------------|
| 4179150 | 0.5 | 5 | Carbide |
| 4179151 | 0.551 | 5.1 | Carbide |
| 4179152 | 0.62 | 5.1 | Carbide |
| 4179153 | 0.623 | 5.1 | Carbide |
| 4179154 | 0.63 | 5.1 | Carbide |
| 4179155 | 0.722 | 5.2 | Carbide |
| 4179156 | 0.862 | 5.4 | Carbide |
| 4179157 | 0.895 | 5.4 | Carbide |
| 4179158 | 0.965 | 5.5 | Carbide |
| 4170550 | 1 | 5.5 | Carbide |
| 4179159 | 1.1 | 5.6 | Carbide |
| 4179160 | 1.118 | 5.6 | Carbide |
| 4170551 | 1.25 | 5.8 | Carbide |
| 4179161 | 1.125 | 5.6 | Carbide |
| 4179162 | 1.35 | 5.9 | Carbide |
| 4179163 | 1.372 | 5.9 | Carbide |
| 4179164 | 1.385 | 5.9 | Carbide |
| 4170552 | 1.5 | 6 | Carbide |
| 4179165 | 1.524 | 6 | Carbide |
| 4179166 | 1.54 | 6 | Carbide |
| 4179167 | 1.6 | 6.1 | Carbide |
| 4179168 | 1.65 | 6.2 | Carbide |
| 4179169 | 1.7 | 6.2 | Carbide |
| 4170553 | 1.75 | 6.3 | Carbide |
| 4179170 | 1.782 | 6.3 | Carbide |
| 4179171 | 1.8 | 6.3 | Carbide |
| 4179172 | 1.829 | 6.3 | Carbide |
| 4179173 | 1.9 | 6.4 | Carbide |
| 4170554 | 2 | 6.5 | Carbide |
| 4170568 | 2.032 | 6.5 | Carbide |
| 4170569 | 2.2 | 6.7 | Carbide |
| 4170564 | 2.25 | 6.8 | Carbide |
| 4179174 | 2.284 | 6.8 | Carbide |

| Order no. | d mm | h mm | Measuring surface |
|-----------|---------|---------|----------------------|
| 4179175 | 2.386 | 6.9 | Carbide |
| 4179176 | 2.438 | 6.9 | Carbide |
| 4170556 | 2.5 | 7 | Carbide |
| 4179177 | 2.667 | 7.2 | Carbide |
| 4179178 | 2.704 | 7.2 | Carbide |
| 4179179 | 2.713 | 7.2 | Carbide |
| 4179180 | 2.721 | 7.2 | Carbide |
| 4179181 | 2.743 | 7.2 | Carbide |
| 4170565 | 2.75 | 7.3 | Carbide |
| 4170557 | 3 | 7.5 | Carbide |
| 4179182 | 3.048 | 7.5 | Carbide |
| 4170570 | 3.2 | 7.7 | Carbide |
| 4170566 | 3.25 | 7.8 | Carbide |
| 4179183 | 3.4 | 7.9 | Carbide |
| 4170558 | 3.5 | 8 | Carbide |
| 4179184 | 3.658 | 8.2 | Carbide |
| 4170571 | 3.7 | 8.2 | Carbide |
| 4170559 | 4 | 8.5 | Carbide |
| 4170560 | 4.5 | 9 | Carbide |
| 4179185 | 4.835 | 9.3 | Carbide |
| 4170561 | 5 | 9.5 | Carbide |
| 4179186 | 5.25 | 9.8 | Carbide |
| 4179187 | 5.486 | 10 | Carbide |
| 4170562 | 5.5 | 10 | Carbide |
| 4170563 | 6 | 10.5 | Carbide |
| 4179188 | 6.096 | 10.6 | Carbide |
| 4179189 | 6.35 | 10.9 | Carbide |
| 4170567 | 6.5 | 11 | Carbide |
| 4170572 | 7 | 11.5 | Carbide |
| 4170573 | 8 | 12.5 | Carbide |
| 4170574 | 9 | 13.5 | Carbide |
| 4170575 | 10 | 14.5 | Carbide |

Marameter

Carbide roller blades

FEATURES

- For gear measurement and for special tasks
- Carbide contact roller
- Cylindrical mounting shank with circlip for mounting in the mounting bore of the micrometer or indicating snap gage

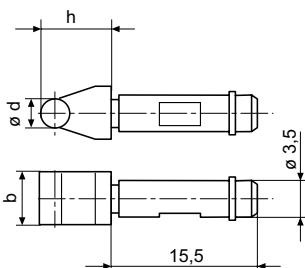

| Order no. | B mm | b mm | d mm | h mm | Measuring surface |
|-----------|---------|---------|---------|---------|----------------------|
| 4510200 | 5.00 | 5 | 1 | 5.5 | Carbide |
| 4510201 | 5.00 | 5 | 1.25 | 5.8 | Carbide |
| 4510202 | 5.00 | 5 | 1.5 | 6 | Carbide |
| 4510203 | 5.00 | 5 | 1.75 | 6.3 | Carbide |
| 4510204 | 5.50 | 5 | 2 | 6.5 | Carbide |
| 4510206 | 5.50 | 5.5 | 2.5 | 7 | Carbide |
| 4510207 | 5.50 | 5.5 | 3 | 7.5 | Carbide |
| 4510208 | 5.50 | 5.5 | 3.5 | 8 | Carbide |
| 4510209 | 5.50 | 5.5 | 4 | 8.5 | Carbide |
| 4510210 | 5.50 | 5.5 | 4.5 | 9 | Carbide |
| 4510211 | 6.00 | 6 | 5 | 9.5 | Carbide |
| 4510212 | 6.00 | 6 | 5.5 | 10 | Carbide |
| 4510213 | 6.00 | 6 | 6 | 10.5 | Carbide |

Marameter 853

Indicating thread snap gage

FEATURES

- Rugged, forged steel frame with heat insulators
- Measuring spindle is mounted in long guideway with lever controlled retraction
- Anvil spindle adjustable with thumbscrew via worm and rack, for mounting interchangeable support yokes
- Measuring spindle and anvil are made of hardened stainless steel with mounting bore for insertion of interchangeable anvils
- Anvil spindle can easily be fine adjusted
- Constant measuring force as a result of built-in spring, eliminating user influence
- Maximum wear resistance due to noncontact positioning
- **Package contains:** flat contact point 903 (steel), wooden case, excludes indicator



Applications:

- For pitch, root and outside diameters on taps in conjunction with interchangeable anvils
- Universally applicable and extremely versatile; each instrument spans a broad measuring range

TECHNICAL DATA

| Order no. | 4511000 | | 4511001 | |
|----------------------|---------------|-------------|---------|-----------|
| Type | | | 853 | |
| Application range mm | mm | 1.2 – 35 | | 35 – 75 |
| Application range | inch | .04 – 1.37" | | 1.37 – 3" |
| Measuring span | mm | | | 8 |
| Repeatability f_w | μm | | | 2 |
| Measuring force | N | | | 7.5 |

| Order no. | a | b | c | e | f | g | h | n |
|-----------|------|-----|-----|----|-----|----|------|----|
| | mm | mm | mm | mm | mm | mm | mm | mm |
| 4511000 | 12 | 152 | 66 | 60 | 98 | 14 | 11.5 | 8 |
| 4511001 | 11.5 | 192 | 110 | 65 | 125 | 14 | 14 | 8 |

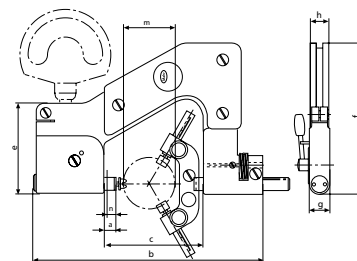

ACCESSORIES

| Order no. | Description | Type |
|-----------|---|----------|
| 4334001 | Millimess 2 μm , $\pm 130 \mu\text{m}$ | 1003 XL |
| 4333000 | Millimess 5 μm , $\pm 130 \mu\text{m}$ | 1004 |
| 4332000 | Millimess 0.01 μm , $\pm 0.25 \text{ mm}$ | 1010 |
| 4337620 | Digital indicator, 0.0005 mm, 12.5 mm | 1086 R |
| 4337624 | Digital indicator, 0.0005 mm, 12.5 mm | 1086 Ri |
| 4511024 | Interchangeable support yoke 3 flutes of taps for 1.2–35 mm range | 853 qk 3 |
| 4511025 | Interchangeable support yoke 3 flutes of taps for 35–75 mm range | 853 qg 3 |
| 4511026 | Interchangeable support yoke 5 flutes of taps for 1.2–35 mm range | 853 qk 5 |
| 4511027 | Interchangeable support yoke 5 flutes of taps for 35–75 mm range | 853 qg 5 |
| 4511028 | Interchangeable support yoke 7 flutes of taps for 1.2–35 mm range | 853 qk 7 |
| 4511029 | Interchangeable support yoke 7 flutes of taps for 35–75 mm range | 853 qg 7 |
| 4511190 | Anvil flat, carbide tipped, $\varnothing 7.5 \text{ mm}$ | 40 Za |
| 4173210 | Anvil flat, hardened steel, $\varnothing 7.5 \text{ mm}$ | 40 Za |



1004



1086 R

Marameter thread anvils

Indicating thread snap gage

FEATURES

- For pitch diameters
- Wear-resistant special steel, hardened
- With cylindrical mounting shank and retainer ring for rotatable mounting in the bore of the dial comparator snap gage
- Adjustment with threaded setting plug 715 E

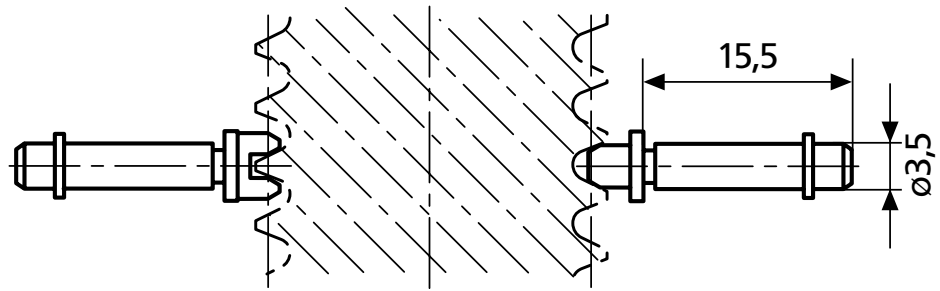

ACCESSORIES

| Thread pitch | Blade Order no. | V-anvil Order no. |
|--|--------------------|----------------------|
| Pitch diameter, external thread | | |
| Metric 60° | | |
| 0.2 | 4173051 | 4174007 |
| 0.25 | 4173052 | 4174008 |
| 0.3 | 4173053 | 4174009 |
| 0.35 | 4173054 | 4174010 |
| 0.4 | 4173055 | 4174011 |
| 0.45 | 4173056 | 4174012 |
| 0.5–0.7 | 4173000 | 4174000 |
| 0.7–1 | 4173001 | 4174001 |
| 1.25–2 | 4173002 | 4174002 |
| 2–3.5 | 4173003 | 4174003 |
| 3.5–5 | 4173004 | 4173704 |
| 5–7 | 4173005 | 4174005 |
| 7–9 | 4173006 | 4174006 |

| Thread pitch in TPI | Blade Order no. | V-anvil Order no. |
|----------------------|--------------------|----------------------|
| UST 60° | | |
| 60–48 | 4173124 | 4176113 |
| 48–40 | 4173125 | 4176114 |
| 40–32 | 4173115 | 4176115 |
| 32–24 | 4173116 | 4176116 |
| 24–18 | 4173117 | 4176117 |
| 18–14 | 4173118 | 4176118 |
| 14–10 | 4173119 | 4176119 |
| 10–7 | 4173120 | 4176120 |
| 7–4.5 | 4173121 | 4176121 |
| 4.5–3 | 4173122 | 4176122 |
| Whitworth 55° | | |
| 40–32 | 4173043 | 4176043 |
| 32–24 | 4173044 | 4176044 |
| 24–18 | 4173045 | 4176045 |
| 18–14 | 4173046 | 4176046 |
| 14–10 | 4173047 | 4176047 |
| 10–7 | 4173048 | 4176048 |
| 7–4.5 | 4173049 | 4176049 |
| 4.5–3 | 4173050 | 4176050 |
| 3–2.5 | 4179408 | 4179411 |



FEATURES

- Indicator built into gage frame for maximum ruggedness
- Lift lever for one hand operation
- Continuous reading dials with revolution counter for absolute measurement of thin materials, plastic films and small parts
- 6.3 mm / .25" diameter, flat steel contacts
- **Data interface:** Digimatic, RS-232C, USB
- **Energy supply:** battery operation
- **Package contains:** includes indicator

Application:

- Thickness measurement of small parts from 0 to 1.0 inch



TECHNICAL DATA

| Order no. | | 2057541 |
|---|------|--|
| Type | | XLI-22P-20 |
| Measuring range | mm | 0 – 25 |
| Measuring range | inch | 0 – 1" |
| Jaw depth | mm | 50 |
| Resolution | mm | 0.0005, 0.001, 0.002, 0.005, 0.01 |
| Resolution | inch | .00002", .00005", .0001", .0002", .0005" |
| Size of measuring surface | | 6.3 mm / 0.25" steel contacts |
| Indicating instrument (included in package) | | 4337651 (1086 ZR) |

ACCESSORIES

| Order no. | Description | Type |
|-----------|--|-------|
| 2003150 | Base/bench stand for 300P or 1000P style snap gage | BA-26 |

Marameter 22P-11 / 22P-15 / 22P-20

Portable thickness gages

FEATURES

- Indicator built into gage frame for maximum ruggedness
- Lift lever for one hand operation
- Continuous reading dials with revolution counter for absolute measurement of thin materials, plastic films and small parts
- 6.3 mm / .25" diameter, flat steel contacts
- **Data interface:** none
- **Package contains:** includes indicator



Application:

- Thickness measurement of small parts from 0 to 1.0 inch, depending on model

TECHNICAL DATA

| Order no. | | 2050446 | 2050447 | 2050449 |
|---|------|-----------------------------------|---------------------------------|---------------------------------|
| Type | | 22P-11 | 22P-15 | 22P-20 |
| Measuring range | inch | 0 – .10" | 0 – .50" | 0 – 1" |
| Scale graduation value | inch | .0001" | .001" | |
| Size of measuring surface | | 6.3 mm / 0.25" steel contacts | | |
| Indicating instrument (included in package) | | Integral indicator (22IN-RC dial) | Integral indicator (28IQN dial) | Integral indicator (28ISN dial) |

ACCESSORIES

| Order no. | Description | Type |
|-----------|--|-------|
| 2003150 | Base/bench stand for 300P or 1000P style snap gage | BA-26 |

Marameter 22P–10M / 22P–15M / 22P–20M

Portable thickness gages

FEATURES

- Indicator built into gage frame for maximum ruggedness
- Lift lever for one hand operation
- Continuous reading dials with revolution counter for absolute measurement of thin materials, plastic films and small parts
- 6.3 mm / .25" diameter, flat steel contacts
- **Data interface:** none
- **Package contains:** includes indicator



Application:

- Thickness measurement of small parts from 0 to 25.4mm

TECHNICAL DATA

| Order no. | 2050445 | 2050448 | 2050450 |
|---|----------------------------------|----------------------------------|---------|
| Type | 22P–10M | 22P–15M | 22P–20M |
| Measuring range | mm 0 –2.54 | 0 –12.7 | 0 –25 |
| Jaw depth | mm 28.6 | | 50 |
| Readings | inch 0.002 | | 0.01 |
| Size of measuring surface | 6.3 mm / 0.25" steel contacts | | |
| Indicating instrument (included in package) | Integral indicator (P11-RC dial) | Integral indicator (26I-RC dial) | |

ACCESSORIES

| Order no. | Description | Type |
|-----------|--|-------|
| 2003150 | Base/bench stand for 300P or 1000P style snap gage | BA–26 |

Marameter XLI-57B-15

Portable thickness gages



FEATURES

- Solid casting with ribbed frame provides strength and rigidity for accurate measurements
- 0.003 mm / .0001" parallelism with tables up to 19 mm / .75" diameter
- 283 g / 10 oz. dead weight load for constant gaging pressure
- 10 mm / .407" diameter flat upper 54.0 mm / 2.125" lower contacts
- Indicator mounts with adjustable back for quick positioning for each gaging requirement
- Digital indicator includes Integrated Wireless transmitter
- With lift lever so work can be easily placed between the table and contact
- Four inch throat depth for part clearance
- **Data interface:** Digimatic, RS-232C, USB, Integrated Wireless
- **Energy supply:** battery operation
- **Package contains:** includes indicator



Application:

- Precision thickness measurement requiring dead weight load force

TECHNICAL DATA

| Order no. | | 2057551 |
|---|------|--|
| Type | | XLI-57B-15 |
| Measuring range | mm | 0 -25 |
| Measuring range | inch | 0 -1" |
| Jaw depth | mm | 102 |
| Resolution | mm | 0.0005, 0.001, 0.002, 0.005, 0.01 |
| Resolution | inch | 0.00002, 0.00005, 0.0001, 0.0002, 0.0005 |
| Parallelism deviation | µm | 3 |
| Measuring force | N | 2.78 N / 10 oz dead weight |
| Indicating instrument (included in package) | | 4337628 (1086Ri) |

Marameter 57B–14 / 57B–15

Portable thickness gages

FEATURES

- Solid casting with ribbed frame provides strength and rigidity for accurate measurements
- 0.003 mm / .0001" parallelism with tables up to 19 mm / .75" diameter
- 283 g / 10 oz. dead weight load for constant gaging pressure
- 10 mm / .407" diameter flat upper 54.0 mm / 2.125" lower contacts
- Indicator mounts with adjustable back for quick positioning for each gaging requirement
- Digital indicator includes Integrated Wireless transmitter
- With lift lever so work can be easily placed between the table and contact
- Four inch throat depth for part clearance
- **Data interface:** none
- **Package contains:** includes indicator



Application:

- Precision thickness measurement requiring dead weight load force

TECHNICAL DATA

| Order no. | | 2050982 | 2050984 |
|---|------|----------------------------|--------------------------|
| Type | | 57B–14 | 57B–15 |
| Measuring range | inch | 0 – .10" | 0 – 1" |
| Scale graduation value | inch | .0001" | .001" |
| Resolution | inch | 0.0001 | 0.001 |
| Measuring force | N | 2.78 N (10oz dead weight) | |
| Indicating instrument (included in package) | | IDT–340 Indicator (32I-RC) | IDS–341 Indicator (D8IS) |

Marameter 57B–14M / 57B–15M

Portable thickness gages

FEATURES

- Solid casting with ribbed frame provides strength and rigidity for accurate measurements
- 0.003 mm / .0001" parallelism with tables up to 19 mm / .75" diameter
- 283 g / 10 oz. dead weight load for constant gaging pressure
- 10 mm / .407" diameter flat upper 54.0 mm / 2.125" lower contacts
- Indicator mounts with adjustable back for quick positioning for each gaging requirement
- Digital indicator includes Integrated Wireless transmitter
- With lift lever so work can be easily placed between the table and contact
- Four inch throat depth for part clearance
- **Data interface:** none
- **Package contains:** includes indicator



Application:

- Precision thickness measurement requiring dead weight load force

TECHNICAL DATA

| Order no. | 2050983 | | 2050985 | |
|---|---------|----------------------------|---------|---------------------------|
| Type | | 57B–14M | | 57B–15M |
| Measuring range | mm | 0 –2.5 | | 0 –25 |
| Jaw depth | mm | | 102 | |
| Readings | | 0.002 | | 0.01 |
| Measuring force | N | 2.78 N (10 oz dead weight) | | |
| Indicating instrument (included in package) | | IDS–342 indicator (Q11-RC) | | IDS–343 indicator (SQ6IS) |



FEATURES

- Using the basic design of the Model 57B-13 gage, the lower contact is PT-103, 1.10 mm / .043" diameter rod, mounted horizontally
- Upper contact is a flat chisel contact in line with the rod
- By slipping tubular parts onto the lower contact, the gage can measure the wall thickness of the tube
- An auxiliary weight on the indicator provides a total dead weight load of 25 grams
- Digital indicator includes integrated wireless transmitter
- **Data interface:** Digimatic, Opto RS-232C, USB, Integrated Wireless
- **Energy supply:** battery operation
- **Package contains:** includes indicator



Application:

- For checking wall thickness of wire insulation and other small diameter tubular parts

TECHNICAL DATA

| Order no. | 2057550 | |
|---|------------------|--|
| Type | XLI-57B-13 | |
| Measuring range | mm | 0 - 7.62 |
| Measuring range | inch | 0 - .30" |
| Jaw depth | mm | 102 |
| Resolution | mm | 0.0005, 0.001, 0.002, 0.005, 0.01 |
| Resolution | inch | 0.00002, 0.00005, 0.0001, 0.0002, 0.0005 |
| Measuring force | N | 0.25 |
| Indicating instrument (included in package) | 4337628 (1086Ri) | |

ACCESSORIES

| Order no. | Description | Type |
|-----------|--|---------|
| 2225698 | Replacement rod for PT-103 pin, 0.043" diameter 0.687" length | PS-43 |
| 2225741 | Pin, Ø=1.10mm / .043", lower contact 1.10 mm / 0.043" diameter pin, lower contact assembly | PT-103 |
| 2225869 | Pin, Ø=0.05mm / .02", lower contact 0.050 mm / 0.020 in diameter pin, lower contact assembly | PT-2245 |

Marameter 57B-13

Portable thickness gages

FEATURES

- Using the basic design of the Model 57B-13 gage, the lower contact is PT-103, 1.10 mm / .043" diameter rod, mounted horizontally
- Upper contact is a flat chisel contact in line with the rod
- By slipping tubular parts onto the lower contact, the gage can measure the wall thickness of the tube
- An auxiliary weight on the indicator provides a total dead weight load of 25 grams
- Digital indicator includes Integrated Wireless transmitter
- **Data interface:** none
- **Package contains:** includes indicator



Application:

- For checking wall thickness of wire insulation and other small diameter tubular parts

TECHNICAL DATA

| Order no. | 2050980 | |
|---|---------|----------------------------|
| Type | | 57B-13 |
| Measuring range | inch | 0 – .30" |
| Jaw depth | mm | 102 |
| Scale graduation value | inch | .0005" |
| Resolution | inch | 0.0005 |
| Measuring force | N | 0.25 |
| Indicating instrument (included in package) | | IDS-116 indicator (25M-RC) |

ACCESSORIES

| Order no. | Description | Type |
|-----------|--|---------|
| 2225698 | Replacement rod for PT-103 pin, 0.043" diameter 0.687" length | PS-43 |
| 2225741 | Pin, Ø=1.10mm / .043", lower contact 1.10 mm / 0.043" diameter pin, lower contact assembly | PT-103 |
| 2225869 | Pin, Ø=0.05mm / .02", lower contact 0.050 mm / 0.020 in diameter pin, lower contact assembly | PT-2245 |

Marameter 57B–13M

Portable thickness gages

FEATURES

- Using the basic design of the Model 57B–13 gage, the lower contact is PT–103, 1.10 mm / .043" diameter rod, mounted horizontally
- Upper contact is a flat chisel contact, in line with the rod
- By slipping tubular parts onto the lower contact, the gage can measure the wall thickness of the tube
- An auxiliary weight on the indicator provides a total dead weight load of 25 grams
- Digital indicator includes Integrated Wireless transmitter
- **Data interface:** none
- **Package contains:** includes indicator



Application:

- For checking wall thickness of wire insulation and other small diameter tubular parts

TECHNICAL DATA

| Order no. | 2050981 | |
|---|---------|----------------------------|
| Type | | 57B–13M |
| Measuring range | mm | 0 –7.6 |
| Jaw depth | mm | 102 |
| Readings | | 0.01 |
| Measuring force | N | 0.25 |
| Indicating instrument (included in package) | | IDS–287 indicator (26I-RC) |

Marameter EMD-57B-11 / EMD-57B-11D

Portable thickness gages



FEATURES

- Solid casting with ribbed frame provides strength and rigidity for accurate measurements
- Furnished with a lift lever so work can be easily placed between the contacts
- Large 54 mm/ 2.125" diameter lower anvil provides convenient stage for small parts or flat materials
- 4.75 mm/ .187" diameter radiused upper contact normally provided
- 102 mm/ 4" throat depth for part clearance
- Indicator mounts with adjustable back for quick positioning for each gaging requirement
- Available with dial indicator or digital electronic indicator
- **Data interface:** none
- **Energy supply:** battery operation
- **Package contains:** includes indicator



Application:

- Precision thickness measurement

TECHNICAL DATA

| Order no. | | 2051884 | 2051885 | 2057548 | 2057549 |
|---|------|----------------------------------|-------------------|--|-------------------|
| Type | | EMD-57B-11 | EMD-57B-11D | | |
| Measuring range | mm | 0 – 21.5 | | 0 – 25 | 0 – 12.5 |
| Measuring range | inch | 0 – 1" | | | |
| Jaw depth | mm | 102 | | | |
| Resolution | mm | 0.0005, 0.001, 0.005 | | 0.0005, 0.001, 0.002, 0.005, 0.01 | |
| Resolution | inch | 0.00002, 0.00005, 0.0001, 0.0005 | | 0.00002, 0.00005, 0.0001, 0.0002, 0.0005 | |
| Indicating instrument (included in package) | | 2033101 Maxµm III | 2033111 Maxµm III | 4337651 (1086ZR) | 4337650 (1086 ZR) |

Marameter 57B–11 / 57B–12

Portable thickness gages

FEATURES

- Solid casting with ribbed frame provides strength and rigidity for accurate measurements
- Furnished with a lift lever so work can be easily placed between the contacts
- Large 54 mm/ 2.125" diameter lower anvil provides convenient stage for small parts or flat materials
- 4.75 mm/ .187" diameter radiused upper contact normally provided
- 102 mm/ 4" throat depth for part clearance
- Indicator mounts with adjustable back for quick positioning for each gaging requirement
- Available with dial indicator or digital electronic indicator
- **Data interface:** none
- **Package contains:** includes indicator



Application:

- Precision thickness measurement

TECHNICAL DATA

| Order no. | | 2050976 | 2050978 |
|---|------|--------------------------|----------------------------|
| Type | | 57B–11 | 57B–12 |
| Measuring range | inch | 0 –1" | 0 –.50" |
| Jaw depth | mm | | 102 |
| Scale graduation value | inch | .001" | .0005" |
| Resolution | inch | 0.001 | 0.0005 |
| Indicating instrument (included in package) | | IDS–160 indicator (D8IS) | IDS–161 indicator (D7I-RC) |

Marameter 57B–11M / 57B–12M

Portable thickness gages

FEATURES

- Solid casting with ribbed frame provides strength and rigidity for accurate measurements
- Furnished with a lift lever so work can be easily placed between the contacts
- Large 54 mm/ 2.125" diameter lower anvil provides convenient stage for small parts or flat materials
- 4.75 mm/ .187" diameter radiused upper contact normally provided
- 102 mm/ 4" throat depth for part clearance
- Indicator mounts with adjustable back for quick positioning for each gaging requirement
- Available with dial indicator or digital electronic indicator
- **Data interface:** none
- **Package contains:** includes indicator



Application:

- Precision thickness measurement

TECHNICAL DATA

| Order no. | 2050977 | 2050979 |
|---|---------------------------|--------------------------|
| Type | 57B–11M | 57B–12M |
| Measuring range | mm 0–25 | 0–12.5 |
| Jaw depth | mm 102 | |
| Readings | | 0.01 |
| Indicating instrument (included in package) | IDS–285 indicator (SQ6IS) | IDS–286 indicator (SQ6I) |

Marameter 838 TAZ

Caliper gage for external measurement



FEATURES

- Contact points made of carbide
- Absolute measuring instrument
- Easy-to-read tolerance markers
- IP protection category: IP 65
- Package contains: test certificate
- Easy to operate, portable and user-friendly

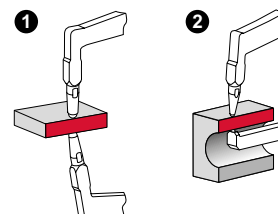

Application:

- For measuring thicknesses and wall thicknesses

TECHNICAL DATA

| Order no. | Type | Measuring range | Scale graduation value | Measuring depth | Error limit G_e | Dimension L | Form of measuring contacts | Measuring force |
|-----------|---------|-----------------|------------------------|-----------------|-------------------|-------------|----------------------------|-----------------|
| | | inch | inch | inch | inch | inch | | N |
| 4495950 | 838 TAZ | 0 – .40" | .0002" | 1.37" | 0.0008 | 1.37" | 1 | 0.8 – 1.2 |
| 4495951 | 838 TAZ | 0 – .80" | .0005" | 3.2" | 0.0015 | 3.2" | 1 | 1.1 – 1.6 |
| 4495952 | 838 TAZ | 0 – .80" | .0005" | 3.2" | 0.0015 | 3.2" | 2 | 1.1 – 1.6 |
| 4495955 | 838 TAZ | 0 – 2.0" | .001" | 6.6" | 0.002 | 6.6" | 1 | 0.8 – 1.7 |
| 4495956 | 838 TAZ | 0 – 2.0" | .001" | 6.7" | 0.002 | 6.7" | 2 | 0.8 – 1.7 |

| Order no. | Dimension L |
|-----------|-------------|
| | inch |
| 4495950 | 1.37" |
| 4495951 | 3.2" |
| 4495952 | 3.2" |
| 4495955 | 6.6" |
| 4495956 | 6.7" |

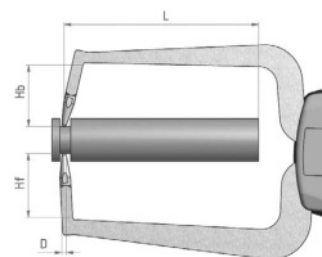

Marameter 838 TA

Caliper gage for external measurement

FEATURES

- Contact points made of carbide
- Absolute measuring instrument
- Easy-to-read tolerance markers
- IP protection category: IP 65
- Package contains:
test certificate
- Easy to operate, portable and user-friendly

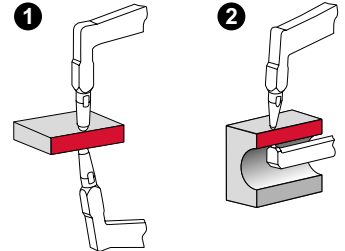

Application:

- For measuring thicknesses and wall thicknesses

TECHNICAL DATA

| Order no. | Type | Appli- cation range | Measuring range | Rea- dings | Mea- suring depth | Error limit | Repea- tability | Dimen- sion L | Form of measuring contacts | Measuring contact ball diameter | Mea- suring force |
|-----------|--------|---------------------------|--------------------|---------------|-------------------------|----------------|--------------------|------------------|----------------------------------|---------------------------------------|-------------------------|
| | | mm | mm | inch | mm | mm | mm | mm | | mm | N |
| 4495550 | 838 TA | 0 – 10 | 0 – 10 | 0.005 | 35 | 0.015 | 0.005 | 35 | 1 | 1.5 | 0.8 – 1.2 |
| 4495551 | 838 TA | 0 – 20 | 0 – 20 | 0.01 | 85 | 0.03 | 0.01 | 85 | 1 | 1.5 | 1.1 – 1.6 |
| 4495552 | 838 TA | 0 – 20 | 0 – 20 | 0.01 | 85 | 0.03 | 0.01 | 85 | 2 | 1.5 | 1.1 – 1.6 |
| 4495555 | 838 TA | 0 – 50 | 0 – 50 | 0.05 | 167 | 0.05 | 0.025 | 167 | 1 | 3 | 0.8 – 1.7 |
| 4495556 | 838 TA | 0 – 50 | 0 – 50 | 0.05 | 169 | 0.05 | 0.025 | 169 | 2 | 3 | 0.8 – 1.7 |

| Order no. | D | Hb | Hf | L |
|-----------|-----|------|------|-----|
| | mm | mm | mm | mm |
| 4495550 | 1.5 | 19.1 | 18.6 | 35 |
| 4495551 | 1.5 | 24.6 | 24.6 | 85 |
| 4495552 | 1.5 | 24.6 | 2.5 | 85 |
| 4495555 | 3 | 30 | 30 | 167 |
| 4495556 | 3 | 30 | 4.3 | 169 |

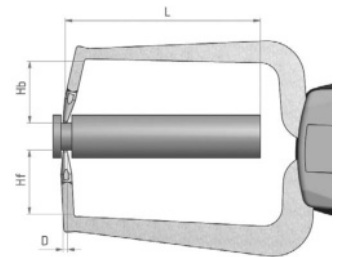

Marameter 838 EA

Digital outer quick probe



FUNCTIONS

- ON/OFF
- mm/inch
- TOL (enter tolerance limit values)
- ABS (display can be set to zero without losing reference to preset)
- DATA (in connection with data interface)

FEATURES

- High contrast analog and digital LCD
- Tolerance displayed via LED (red/green)
- **Data interface:** Digimatic, USB, Bluetooth (optional accessory)
- **Energy supply:** Battery operation (2x 1.5V AAA)
- **IP protection category:** IP 67
- **Package contains:** instruction manual, battery, test certificate

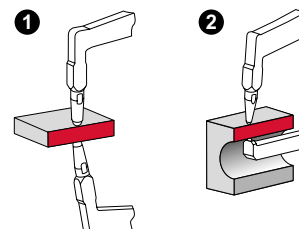

Application:

- Specified measuring programs according to application
- Absolute/relative measuring program

TECHNICAL DATA

| Order no. | Type | Measuring range | Resolution | Measuring depth | Error limit | Repeatability | Form of measuring contacts | Measuring contact ball diameter | Measuring force | Bluetooth option |
|-----------|--------|-----------------|---------------------------------------|-----------------|-------------|---------------|----------------------------|---------------------------------|-----------------|------------------|
| | | mm | mm | mm | mm | mm | | mm | N | |
| 4495450 | 838 EA | 0–10 | 0.001, 0.002, 0.005, 0.01, 0.02, 0.05 | 35 | 0.015 | 0.005 | 1 | 1.5 | 0.8–1.2 | • |
| 4495451 | 838 EA | 0–20 | 0.001, 0.002, 0.005, 0.01, 0.02, 0.05 | 85 | 0.03 | 0.01 | 1 | 1.5 | 1.1–1.6 | • |
| 4495452 | 838 EA | 0–20 | 0.001, 0.002, 0.005, 0.01, 0.02, 0.05 | 85 | 0.03 | 0.01 | 2 | 1.5 | 1.1–1.6 | • |
| 4495453 | 838 EA | 0–30 | 0.001, 0.002, 0.005, 0.01, 0.02, 0.05 | 116 | 0.04 | 0.02 | 1 | 3 | 0.9–1.6 | • |
| 4495454 | 838 EA | 0–50 | 0.001, 0.002, 0.005, 0.01, 0.02, 0.05 | 167 | 0.05 | 0.03 | 1 | 3 | 0.8–1.7 | • |
| 4495455 | 838 EA | 0–30 | 0.001, 0.002, 0.005, 0.01, 0.02, 0.05 | 116 | 0.04 | 0.02 | 2 | 3 | 0.9–1.6 | • |
| 4495456 | 838 EA | 0–50 | 0.001, 0.002, 0.005, 0.01, 0.02, 0.05 | 169 | 0.05 | 0.03 | 2 | 3 | 0.8–1.7 | • |

| Order no. | D | Hb | Hf | L |
|-----------|-----|------|------|-----|
| | mm | mm | mm | mm |
| 4495450 | 1.5 | 19.1 | 18.6 | 35 |
| 4495451 | 1.5 | 24.6 | 24.6 | 85 |
| 4495452 | 1.5 | 24.6 | 2.5 | 85 |
| 4495453 | 3 | 30 | 30 | 116 |
| 4495454 | 3 | 30 | 30 | 167 |
| 4495455 | 3 | 30 | 4 | 116 |
| 4495456 | 3 | 30 | 4.3 | 169 |

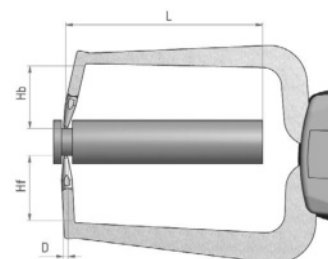

ACCESSORIES

| Order no. | Description | Type |
|-----------|--|------------|
| 4495036 | Bluetooth interface for 838 EI/EA, including USB dongle BT4.0 | 838 BT |
| 4495079 | 838 USB interface adapter with data connection cable USB (1.5 m) | 838 USB |
| 4495083 | Interface adapter with data cable digimatic (1.5 m) | 838 di (A) |



838 BT

Marameter 838 TIZ

Caliper gage for internal measurement



FEATURES

- Contact points made of carbide
- Absolute measuring instrument
- Easy-to-read tolerance markers
- IP protection category: IP 65
- Package contains: test certificate
- Easy to operate, portable and user-friendly



Application:

- For measuring bores and internal grooves

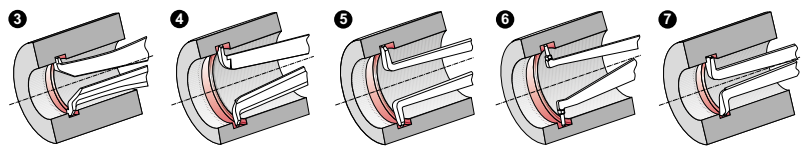

TECHNICAL DATA

| Order no. | 4495980 | 4495981 | 4495982 | 4495983 | 4495984 | 4495985 | 4495986 | 4495987 |
|----------------------------|-----------------|-------------|-------------|--------------|--------------|--------------|-------------|--------------|
| Type | 838 TIZ | | | | | | | |
| Measuring range | inch .20 – .60" | .40 – 1.20" | .80 – 1.60" | 1.20 – 2.00" | 1.60 – 2.40" | 2.00 – 2.80" | .60 – 2.60" | 1.60 – 3.60" |
| Scale graduation value | inch .0002" | .0005" | | | | | | .001" |
| Measuring depth | inch 1.37" | 3.2" | | | | | 7.5" | 7.6" |
| Error limit G_e | inch 0.0008 | 0.0015 | | | | | | 0.002 |
| Form of measuring contacts | 4 | | 5 | | 6 | | 7 | 6 |
| Measuring force | N 0.8 – 1.2 | 1.1 – 1.6 | | | | | 0.9 – 1.9 | |

| Order no. | Dimension L |
|-----------|-------------|
| | inch |
| 4495980 | 1.37" |
| 4495981 | 3.2" |
| 4495982 | 3.2" |
| 4495983 | 3.2" |
| 4495984 | 3.2" |
| 4495985 | 3.2" |
| 4495986 | 7.5" |
| 4495987 | 7.6" |

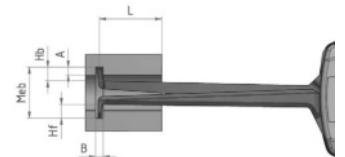

Marameter 838 TI

Caliper gage for internal measurement



FEATURES

- Contact points made of carbide
- Absolute measuring instrument
- Easy-to-read tolerance markers
- IP protection category: IP 65
- Package contains: test certificate
- Easy to operate, portable and user-friendly



Application:

- For measuring bores and internal grooves

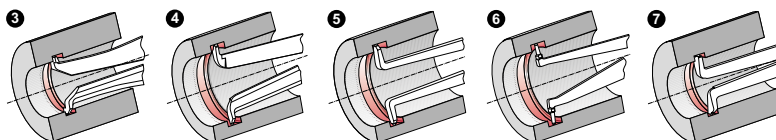

TECHNICAL DATA

| Order no. | | 4495580 | 4495581 | 4495582 | 4495583 | 4495584 | 4495585 | 4495586 | 4495587 | |
|---------------------------------|------|-----------|---------|---------|-----------|---------|---------|-----------|---------|--|
| Type | | 838 TI | | | | | | | | |
| Measuring range | mm | 5 – 15 | 10 – 30 | 20 – 40 | 30 – 50 | 40 – 60 | 50 – 70 | 15 – 65 | 40 – 90 | |
| Readings | inch | 0.005 | | | 0.01 | | | 0.05 | | |
| Measuring depth | mm | 35 | | | 85 | | | 188 | 192 | |
| Error limit | mm | 0.015 | | | 0.03 | | | 0.05 | | |
| Repeatability | mm | 0.005 | | | 0.01 | | | 0.025 | | |
| Groove depth | mm | 2.3 | 5.2 | 7 | | 8.3 | | 5.5 | 8.3 | |
| Groove width | mm | 0.8 | | 1.2 | | 1.9 | | 2.4 | | |
| Form of measuring contacts | | 4 | | 5 | | 6 | | 7 | 6 | |
| Measuring contact ball diameter | mm | 0.6 | | | 1 | | | 1.5 | 2 | |
| Measuring force | N | 0.8 – 1.2 | | | 1.1 – 1.6 | | | 0.9 – 1.9 | | |

| Order no. | A | B | D | Hb | Hf | L |
|-----------|-----|------|-----|------|------|-----|
| | mm | mm | mm | mm | mm | mm |
| 4495580 | 2.3 | 0.80 | 0.6 | 2.5 | 2.5 | 35 |
| 4495581 | 5.2 | 1.20 | 1 | 5.4 | 5.4 | 85 |
| 4495582 | 7 | 1.20 | 1 | 7.3 | 7.3 | 85 |
| 4495583 | 7 | 1.20 | 1 | 7.3 | 7.3 | 85 |
| 4495584 | 8.3 | 1.20 | 1 | 12.2 | 12.2 | 85 |
| 4495585 | 8.3 | 1.20 | 1 | 12.2 | 12.2 | 85 |
| 4495586 | 5.5 | 1.90 | 1.5 | 6 | 6 | 188 |
| 4495587 | 8.3 | 2.40 | 2 | 8.5 | 8.5 | 192 |

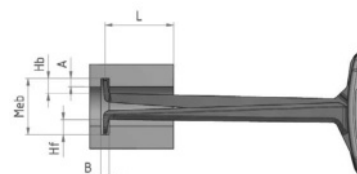

Marameter 838 EI

Digital inside quick probe



FUNCTIONS

- ON/OFF
- mm/inch
- TOL (enter tolerance limit values)
- ABS (display can be set to zero without losing reference to preset)
- DATA (in connection with data interface)

FEATURES

- High contrast analog and digital LCD
- Tolerance displayed via LED (red/green)
- **Data interface:** Digimatic, USB, Bluetooth (optional accessory)
- **Energy supply:** Battery operation (2x 1.5V AAA)
- **IP protection category:** IP 67
- **Package contains:** instruction manual, battery, test certificate

Applications:

- Specified measuring programs according to application
- Absolute/relative measuring program

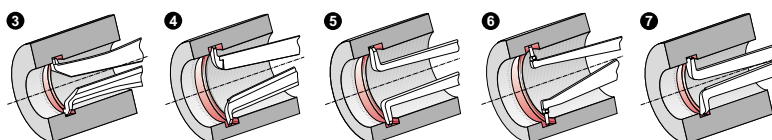

TECHNICAL DATA

| Order no. | 4495460 | 4495461 | 4495462 | 4495463 | 4495464 | 4495465 | 4495468 | 4495469 | 4495470 |
|---------------------------------|--|---------|---------|-----------|---------|---------|---------|-----------|---------|
| Type | 838 EI | | | | | | | | |
| Measuring range | mm 5 – 15 | 10 – 30 | 20 – 40 | 30 – 50 | 40 – 60 | 50 – 70 | 13 – 43 | 30 – 60 | 50 – 80 |
| Resolution | mm 0.001, 0.002, 0.005, 0.01, 0.02, 0.05 | | | | | | | | |
| Measuring depth | mm 35 | | | 85 | | | 127 | | 132 |
| Error limit | mm 0.015 | | | 0.03 | | | | 0.04 | |
| Repeatability | mm 0.005 | | | 0.01 | | | | 0.02 | |
| Groove depth | mm 2.3 | 5.2 | | 7 | | 8.3 | 5.7 | 6.2 | 8.3 |
| Groove width | mm 0.8 | | | 1.2 | | | 1.6 | 1.8 | 2.4 |
| Form of measuring contacts | | 4 | | 5 | | 6 | 4 | | 6 |
| Measuring contact ball diameter | mm 0.6 | | | 1 | | | 1.3 | 1.5 | 2 |
| Measuring force | N 0.8 – 1.2 | | | 1.1 – 1.6 | | | | 1.2 – 1.7 | |
| Bluetooth Option | | | | | | • | | | |

| Order no. | A | B | D | Hb | Hf | L |
|-----------|-----|------|-----|------|------|-----|
| | mm | mm | mm | mm | mm | mm |
| 4495460 | 2.3 | 0.80 | 0.6 | 2.5 | 2.5 | 35 |
| 4495461 | 5.2 | 1.20 | 1 | 5.4 | 5.4 | 85 |
| 4495462 | 7 | 1.20 | 1 | 7.3 | 7.3 | 85 |
| 4495463 | 7 | 1.20 | 1 | 7.3 | 7.3 | 85 |
| 4495464 | 8.3 | 1.20 | 1 | 12.2 | 12.2 | 85 |
| 4495465 | 8.3 | 1.20 | 1 | 12.2 | 12.2 | 85 |
| 4495468 | 5.7 | 1.60 | 1.3 | 5.7 | 5.7 | 127 |
| 4495469 | 6.2 | 1.80 | 1.5 | 6.5 | 6.5 | 132 |
| 4495470 | 8.3 | 2.40 | 2 | 8.5 | 8.5 | 132 |

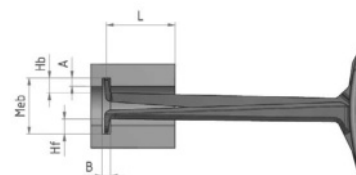

ACCESSORIES

| Order no. | Description | Type |
|-----------|--|------------|
| 4495083 | Interface adapter with data cable digimatic (1.5 m) | 838 di (A) |
| 4495079 | 838 USB interface adapter with data connection cable USB (1.5 m) | 838 USB |
| 4495036 | Bluetooth interface for 838 EI/EA, including USB dongle BT4.0 | 838 BT |



838 BT

Marameter | 844 D indicating plug gage system

Indicating measurement in highest precision

Plug gages of the 844 D family are 2-point indicating gages, combined with a precisely ground guide cylinder, which centers itself exactly in bores. This means that no reversal point needs to be determined by rocking. The measured value is displayed reliably, precisely and immediately.

The adjustment to a respective nominal dimension is achieved with setting rings.

Benefits:

- Fast and easy to use - best performance
- No operator influence
- Self-centering - no rocking required to determine the reversal point
- Especially suitable with use of digital indicators for processing the measured values

The following must be indicated with each order

- Order number
- Bore diameter
- Bore tolerance (ISO or numerical value spec.)

Examples

- | | |
|-------------|---|
| 1 x 4484016 | 844 D indicating plug gage Nominal bore size \varnothing 34.5 mm Bore tolerance H8 |
| 1 x 4484048 | 844 DR indicating plug gage Nominal bore size \varnothing 74.55 mm Bore tolerance +0.05 / -0.03 |

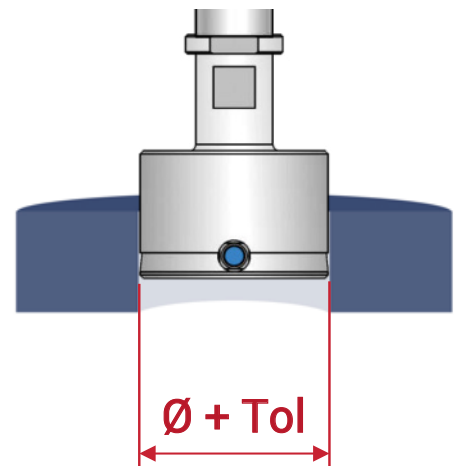

Modular system

By combining with a wide range of accessories (indicators, holders, extensions and right angle attachment), the indicating plug gage becomes a high precision measuring instrument, adapted to the measuring task.

Samples of application configurations



Standard configuration

- Comparator
- Holder 844 Dg
- Plug gage



Configuration for defined measuring depth

- Comparator
- Holder 844 Dg
- Extension 844 Dv
- Depth stop 844 Dt-3
- Plug gage

Configuration for sideways measuring in defined measuring depth

- Comparator
- Holder 844 Dg
- Angle attachment 844 Dw
- Plug gage
- Stop ring 844 Dt-R



Marameter | 844 D indicating plug gage system

3 basic types

Guide cylinder hard chrome-plated, measuring surfaces made of carbide

844 D

Standard version for general applications

- For quick inspection of precise bores

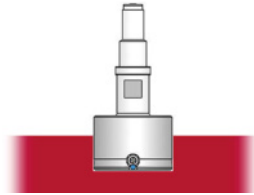
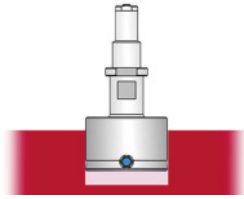

844 DS

Version for blind holes

- For measurements close to the base of the hole

844 DR

Version for through holes and thin-walled holes (metal sheet)

- With extended guide cylinder

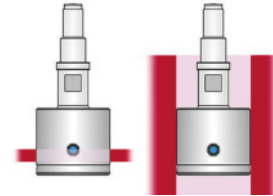

Variants

Variant C: 844 D-C / 844 DR-C / 844 DS-C

Measuring surfaces hard-chrome plated: For sensitive surfaces of non-ferrous metals and aluminum alloys



Variant R: 844 D-R / 844 DR-R / 844 DS-R

Measuring surfaces ruby-tipped: For very sensitive surfaces of non-ferrous metals and aluminum alloys



Variant D: 844 D-D / 844 DR-D

Measuring surfaces diamond-tipped: For very sensitive surfaces of soft non-ferrous metals and aluminum alloys



Variant FD: 844 D-FD / 844 DR-FD

Different front distance „e“: Reducing the guide cylinder to measure closer, or at a defined position, to the ground of the bore

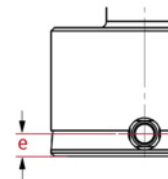

Variant M: 844 D-M / 844 DR-M / 844 DS-M

Extended measuring range: For measuring of larger tolerance fields



Variant HR: 844 D-HR / 844 DR-HR / 844 DS-HR

High resolution for very narrow bore tolerance zones $< 10 \mu\text{m}$.
More precise manufacturing tolerance of the guide cylinder for tighter gap in the bore, thus reducing axial and radial measuring influences.



Variant F: 844 DS-F

Only with front chamfer (no centering groove): For measuring very short blind holes



Variant 3: 844 D-3 / 844 DR-3

3-Point contact ($3 \times 120^\circ$): For fast measurement of interrupted diameters and detection of shape defects in a polygon

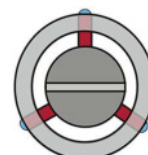

Marameter 844 D

Indicating plug gage

FEATURES

- Measuring head has a hard, stainless cylinder guide and carbide tipped anvils
- The carbide expanding pin transfers radial movement to indicating instrument
- Constant measuring force as a result of built-in spring, eliminating user influence
- Extensive modular system is composed of measuring head, holder, depth extension, right angle attachments and depth stops

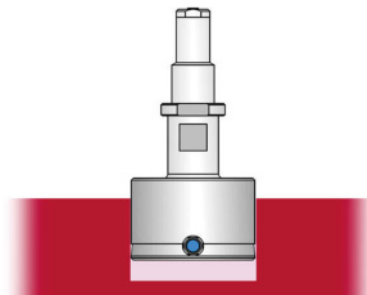

Application: Standard model

- For rapid testing of diameter, roundness and conicity of bores
- Especially suitable for testing batches with tight tolerance zones 10 µm and more
- Rocking in the bore is not required to determine diameter
- Ideal for use in conjunction with digital display units and for subsequent processing of measured values

TECHNICAL DATA

| Order no. | Type | Measuring range | Measuring span | Manufacturing tolerance | Linearity deviation | Repeatability f_w | a | b | c | e | g | Connection thread |
|-----------|-------|-----------------|----------------|-------------------------|---------------------|---------------------|------|------|----|-----|----|-----------------------|
| | | mm | mm | mm / mm | | µm | mm | mm | mm | mm | mm | |
| 4484007 | 844 D | 2- <3 | 0.15 | -0.015 / -0.025 | 1 %, min. 1 µm | 1 | | 21.5 | 15 | 1.5 | 15 | M6 x 0.75 / M3.5x0.35 |
| 4484008 | 844 D | 3-4 | 0.2 | -0.015 / -0.025 | 1 %, min. 1 µm | 1 | | 33.5 | 24 | 1.5 | 24 | M6 x 0.75 / M3.5x0.35 |
| 4484009 | 844 D | >4-7 | 0.2 | -0.015 / -0.025 | 1 %, min. 1 µm | 1 | 4 | 33.5 | 10 | 1.5 | 27 | M6 x 0.75 / M3.5x0.35 |
| 4484010 | 844 D | >7-9 | 0.2 | -0.015 / -0.025 | 1 %, min. 1 µm | 1 | 6.9 | 47 | 15 | 2.5 | 35 | M6 x 0.75 |
| 4484011 | 844 D | >9-12 | 0.2 | -0.015 / -0.025 | 1 %, min. 1 µm | 1 | 7.9 | 47 | 15 | 2.5 | 47 | M6 x 0.75 |
| 4484012 | 844 D | >12-13 | 0.2 | -0.015 / -0.025 | 1 %, min. 1 µm | 1 | 7.9 | 47 | 15 | 2.5 | 47 | M6 x 0.75 |
| 4484013 | 844 D | >13-16 | 0.2 | -0.015 / -0.025 | 1 %, min. 1 µm | 1 | 11.9 | 47 | 15 | 2.5 | 47 | M6 x 0.75 |
| 4484014 | 844 D | >16-20 | 0.2 | -0.015 / -0.025 | 1 %, min. 1 µm | 1 | 15 | 37.3 | 15 | 2.5 | | M10x1 |
| 4484015 | 844 D | >20-30 | 0.2 | -0.02 / -0.03 | 1 %, min. 1 µm | 1 | 15 | 38.2 | 20 | 3.5 | | M10x1 |
| 4484016 | 844 D | >30-40 | 0.2 | -0.02 / -0.03 | 1 %, min. 1 µm | 1 | 15 | 38.2 | 20 | 3.5 | | M10x1 |
| 4484017 | 844 D | >40-60 | 0.2 | -0.02 / -0.03 | 1 %, min. 1 µm | 1 | 15 | 38.2 | 28 | 3.5 | | M10x1 |
| 4484018 | 844 D | >60-80 | 0.2 | -0.025 / -0.035 | 1 %, min. 1 µm | 1 | 17.9 | 38.8 | 33 | 4 | | M10x1 |
| 4484019 | 844 D | >80-100 | 0.2 | -0.025 / -0.035 | 1 %, min. 1 µm | 1 | 17.9 | 38.8 | 33 | 4 | | M10x1 |
| 4484020 | 844 D | >100-110 | 0.2 | -0.025 / -0.035 | 1 %, min. 1 µm | 1 | 17.9 | 38.8 | 33 | 4 | | M10x1 |
| 4484021 | 844 D | >110-120 | 0.2 | -0.025 / -0.035 | 1 %, min. 1 µm | 1 | 17.9 | 38.8 | 33 | 4 | | M10x1 |
| 4484022 | 844 D | >120-130 | 0.2 | -0.025 / -0.035 | 1 %, min. 1 µm | 1 | 17.9 | 38.8 | 33 | 4 | | M10x1 |
| 4484023 | 844 D | >130-140 | 0.2 | -0.035 / -0.045 | 1 %, min. 1 µm | 1 | 17.9 | 38.8 | 33 | 4 | | M10x1 |
| 4484024 | 844 D | >140-150 | 0.2 | -0.035 / -0.045 | 1 %, min. 1 µm | 1 | 17.9 | 38.8 | 33 | 4 | | M10x1 |
| 4484025 | 844 D | >150-160 | 0.2 | -0.035 / -0.045 | 1 %, min. 1 µm | 1 | 17.9 | 38.8 | 33 | 4 | | M10x1 |
| 4484026 | 844 D | >160-170 | 0.2 | -0.035 / -0.045 | 1 %, min. 1 µm | 1 | 17.9 | 39 | 40 | 4 | | M10x1 |
| 4484027 | 844 D | >170-180 | 0.2 | -0.035 / -0.045 | 1 %, min. 1 µm | 1 | 17.9 | 39 | 40 | 4 | | M10x1 |
| 4484028 | 844 D | >180-190 | 0.2 | -0.035 / -0.045 | 1 %, min. 1 µm | 1 | 17.9 | 39 | 40 | 4 | | M10x1 |
| 4484029 | 844 D | >190-200 | 0.2 | -0.035 / -0.045 | 1 %, min. 1 µm | 1 | 17.9 | 39 | 40 | 4 | | M10x1 |

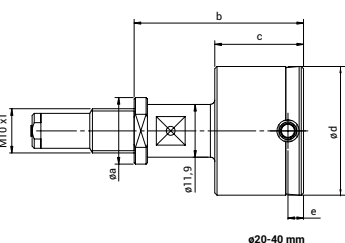
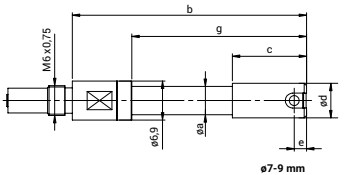
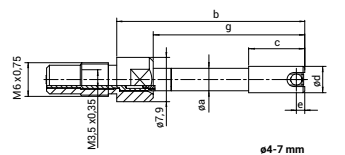

Marameter 844 DR

Indicating plug gage

FEATURES

- Measuring probe made of hardened, stainless guide cylinder and carbide tipped probes
- Carbide driving needle transfers radial measuring movement to the display unit
- Constant measuring force as a result of built-in spring, eliminating user influence
- Measuring head, measuring instrument holder, depth extensions, right angle attachments and depth stops form a comprehensive modular system

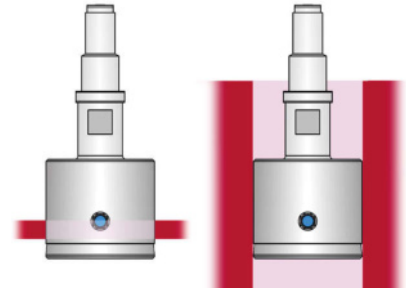

Application:

Model for through holes and narrow parts

- With extended guide cylinder for measuring through holes and bores of narrow parts e.g. sheets
- For the rapid testing of diameter, roundness and conicity of bores
- Especially suitable for testing batches with tight tolerance zones 10 µm and more
- Rocking in the bore is not required to determine diameter
- Ideal for use in conjunction with digital display units and for subsequent processing of measured values

TECHNICAL DATA

| Order no. | Type | Measuring range | Measuring span | Manufacturing tolerance | Linearity deviation | Repeatability f_w | a | b | c | e | g | Connection thread |
|-----------|--------|-----------------|----------------|-------------------------|---------------------|---------------------|------|------|------|----|------|-----------------------|
| | | mm | mm | mm / mm | | µm | mm | mm | mm | mm | mm | |
| 4484039 | 844 DR | 4–7 | 0.2 | −0.015 / −0.025 | 1 %, min. 1 µm | 1 | 4 | 38 | 14.5 | 6 | 31.5 | M6 x 0.75 / M3.5x0.35 |
| 4484040 | 844 DR | >7–9 | 0.2 | −0.015 / −0.025 | 1 %, min. 1 µm | 1 | 6.9 | 50.5 | 18.5 | 6 | 38.5 | M6 x 0.75 |
| 4484041 | 844 DR | >9–12 | 0.2 | −0.015 / −0.025 | 1 %, min. 1 µm | 1 | 7.9 | 54.5 | 22.5 | 10 | 54.5 | M6 x 0.75 |
| 4484042 | 844 DR | >12–13 | 0.2 | −0.015 / −0.025 | 1 %, min. 1 µm | 1 | 7.9 | 54.5 | 22.5 | 10 | 54.5 | M6 x 0.75 |
| 4484043 | 844 DR | >13–16 | 0.2 | −0.015 / −0.025 | 1 %, min. 1 µm | 1 | 11.9 | 54.5 | 22.5 | 10 | 54.5 | M6 x 0.75 |
| 4484044 | 844 DR | >16–20 | 0.2 | −0.015 / −0.025 | 1 %, min. 1 µm | 1 | 15 | 44.8 | 22.5 | 10 | | M10x1 |
| 4484045 | 844 DR | >20–30 | 0.2 | −0.02 / −0.03 | 1 %, min. 1 µm | 1 | 15 | 44.7 | 27 | 10 | | M10x1 |
| 4484046 | 844 DR | >30–40 | 0.2 | −0.02 / −0.03 | 1 %, min. 1 µm | 1 | 15 | 44.7 | 27 | 10 | | M10x1 |
| 4484047 | 844 DR | >40–60 | 0.2 | −0.02 / −0.03 | 1 %, min. 1 µm | 1 | 15 | 44.7 | 28 | 10 | | M10x1 |
| 4484048 | 844 DR | >60–80 | 0.2 | −0.025 / −0.035 | 1 %, min. 1 µm | 1 | 17.9 | 44.8 | 33 | 10 | | M10x1 |
| 4484049 | 844 DR | >80–100 | 0.2 | −0.025 / −0.035 | 1 %, min. 1 µm | 1 | 17.9 | 44.8 | 33 | 10 | | M10x1 |
| 4484050 | 844 DR | >100–110 | 0.2 | −0.025 / −0.035 | 1 %, min. 1 µm | 1 | 17.9 | 44.8 | 33 | 10 | | M10x1 |
| 4484051 | 844 DR | >110–120 | 0.2 | −0.025 / −0.035 | 1 %, min. 1 µm | 1 | 17.9 | 44.8 | 33 | 10 | | M10x1 |
| 4484052 | 844 DR | >120–130 | 0.2 | −0.025 / −0.035 | 1 %, min. 1 µm | 1 | 17.9 | 44.8 | 33 | 10 | | M10x1 |
| 4484053 | 844 DR | >130–140 | 0.2 | −0.035 / −0.045 | 1 %, min. 1 µm | 1 | 17.9 | 44.8 | 33 | 10 | | M10x1 |
| 4484054 | 844 DR | >140–150 | 0.2 | −0.035 / −0.045 | 1 %, min. 1 µm | 1 | 17.9 | 44.8 | 33 | 10 | | M10x1 |
| 4484055 | 844 DR | >150–160 | 0.2 | −0.035 / −0.045 | 1 %, min. 1 µm | 1 | 17.9 | 44.8 | 33 | 10 | | M10x1 |
| 4484056 | 844 DR | >160–170 | 0.2 | −0.035 / −0.045 | 1 %, min. 1 µm | 1 | 17.9 | 45 | 40 | 10 | | M10x1 |
| 4484057 | 844 DR | >170–180 | 0.2 | −0.035 / −0.045 | 1 %, min. 1 µm | 1 | 17.9 | 45 | 40 | 10 | | M10x1 |
| 4484058 | 844 DR | >180–190 | 0.2 | −0.035 / −0.045 | 1 %, min. 1 µm | 1 | 17.9 | 45 | 40 | 10 | | M10x1 |
| 4484059 | 844 DR | >190–200 | 0.2 | −0.035 / −0.045 | 1 %, min. 1 µm | 1 | 17.9 | 45 | 40 | 10 | | M10x1 |

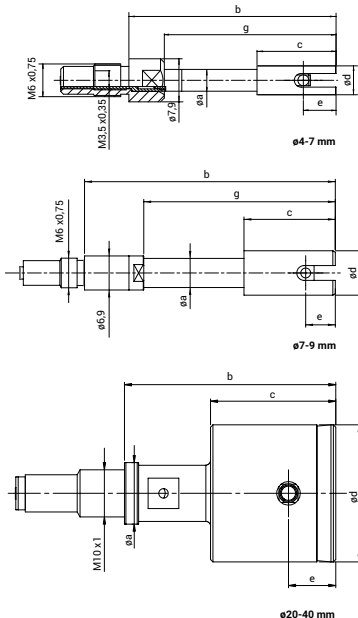

Marameter 844 DS

Indicating plug gage

FEATURES

- Measuring probe made of hardened, stainless guide cylinder and carbide tipped probes
- Carbide driving needle transfers radial measuring movement to the display unit
- Constant measuring force as a result of built-in spring, eliminating user influence
- Measuring head, measuring instrument holder, depth extensions, right angle attachments and depth stops form a comprehensive modular system

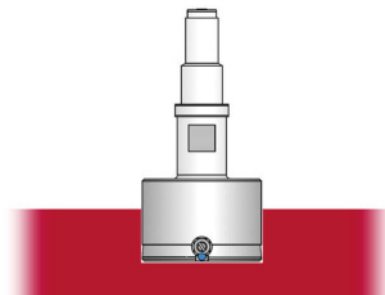

Application: Model for blind holes

- For measurements close to the base of the hole
- For the rapid testing of diameter, roundness and conicity of bores
- Especially suitable for testing batches with tight tolerance zones 10 µm and more
- Rocking in the bore is not required to determine diameter
- Ideal for use in conjunction with digital display units and for subsequent processing of measured values

TECHNICAL DATA

| Order no. | Type | Measuring range | Measuring span | Manufacturing tolerance | Linearity deviation | Repeatability f_w | a | b | c | e | g | Connection thread |
|-----------|--------|-----------------|----------------|-------------------------|---------------------|---------------------|------|------|------|-----|------|-----------------------|
| | | mm | mm | mm / mm | | µm | mm | mm | mm | mm | mm | |
| 4484067 | 844 DS | 2- <3 | 0.15 | -0.015 / -0.025 | 1.5 %, min. 1 µm | 1 | | 20.7 | 14.2 | 0.7 | 14,2 | M6 x 0.75 / M3.5x0.35 |
| 4484068 | 844 DS | 3-4 | 0.2 | -0.015 / -0.025 | 1.5 %, min. 1 µm | 1 | | 33 | 23.5 | 1 | 23.5 | M6 x 0.75 / M3.5x0.35 |
| 4484069 | 844 DS | >4-7 | 0.2 | -0.015 / -0.025 | 1.5 %, min. 1 µm | 1 | 4 | 33 | 9.5 | 1 | 26.5 | M6 x 0.75 / M3.5x0.35 |
| 4484070 | 844 DS | >7-9 | 0.2 | -0.015 / -0.025 | 1.5 %, min. 1 µm | 1 | 6.9 | 45.5 | 13.5 | 1 | 33.5 | M6 x 0.75 |
| 4484071 | 844 DS | >9-12 | 0.2 | -0.015 / -0.025 | 1.5 %, min. 1 µm | 1 | 7.9 | 45.5 | 13.5 | 1 | 45.5 | M6 x 0.75 |
| 4484072 | 844 DS | >12-13 | 0.2 | -0.015 / -0.025 | 1.5 %, min. 1 µm | 1 | 7.9 | 45.5 | 13.5 | 1 | 45.5 | M6 x 0.75 |
| 4484073 | 844 DS | >13-16 | 0.2 | -0.015 / -0.025 | 1.5 %, min. 1 µm | 1 | 11.9 | 45.5 | 13.5 | 1 | 45.5 | M6 x 0.75 |
| 4484074 | 844 DS | >16-20 | 0.2 | -0.015 / -0.025 | 1.5 %, min. 1 µm | 1 | 15 | 35.8 | 13.5 | 1 | | M10x1 |
| 4484075 | 844 DS | >20-30 | 0.2 | -0.02 / -0.03 | 1.5 %, min. 1 µm | 1 | 15 | 38.2 | 20 | 1.2 | | M10x1 |
| 4484076 | 844 DS | >30-40 | 0.2 | -0.02 / -0.03 | 1.5 %, min. 1 µm | 1 | 15 | 38.2 | 20 | 1.2 | | M10x1 |
| 4484077 | 844 DS | >40-60 | 0.2 | -0.02 / -0.03 | 1.5 %, min. 1 µm | 1 | 15 | 38.2 | 28 | 1.2 | | M10x1 |
| 4484078 | 844 DS | >60-80 | 0.2 | -0.025 / -0.035 | 1.5 %, min. 1 µm | 1 | 17.9 | 39 | 33 | 1.2 | | M10x1 |
| 4484079 | 844 DS | >80-100 | 0.2 | -0.025 / -0.035 | 1.5 %, min. 1 µm | 1 | 17.9 | 39 | 33 | 1.2 | | M10x1 |
| 4484080 | 844 DS | >100-110 | 0.2 | -0.025 / -0.035 | 1.5 %, min. 1 µm | 1 | 17.9 | 39 | 33 | 1.2 | | M10x1 |
| 4484081 | 844 DS | >110-120 | 0.2 | -0.025 / -0.035 | 1.5 %, min. 1 µm | 1 | 17.9 | 39 | 33 | 1.2 | | M10x1 |
| 4484082 | 844 DS | >120-130 | 0.2 | -0.025 / -0.035 | 1.5 %, min. 1 µm | 1 | 17.9 | 39 | 33 | 1.2 | | M10x1 |
| 4484083 | 844 DS | >130-140 | 0.2 | -0.035 / -0.045 | 1.5 %, min. 1 µm | 1 | 17.9 | 39 | 33 | 1.2 | | M10x1 |
| 4484084 | 844 DS | >140-150 | 0.2 | -0.035 / -0.045 | 1.5 %, min. 1 µm | 1 | 17.9 | 39 | 33 | 1.2 | | M10x1 |
| 4484085 | 844 DS | >150-160 | 0.2 | -0.035 / -0.045 | 1.5 %, min. 1 µm | 1 | 17.9 | 39 | 33 | 1.2 | | M10x1 |
| 4484086 | 844 DS | >160-170 | 0.2 | -0.035 / -0.045 | 1.5 %, min. 1 µm | 1 | 17.9 | 38.6 | 40 | 1.2 | | M10x1 |
| 4484087 | 844 DS | >170-180 | 0.2 | -0.035 / -0.045 | 1.5 %, min. 1 µm | 1 | 17.9 | 38.6 | 40 | 1.2 | | M10x1 |
| 4484088 | 844 DS | >180-190 | 0.2 | -0.035 / -0.045 | 1.5 %, min. 1 µm | 1 | 17.9 | 38.6 | 40 | 1.2 | | M10x1 |
| 4484089 | 844 DS | >190-200 | 0.2 | -0.035 / -0.045 | 1.5 %, min. 1 µm | 1 | 17.9 | 38.6 | 40 | 1.2 | | M10x1 |

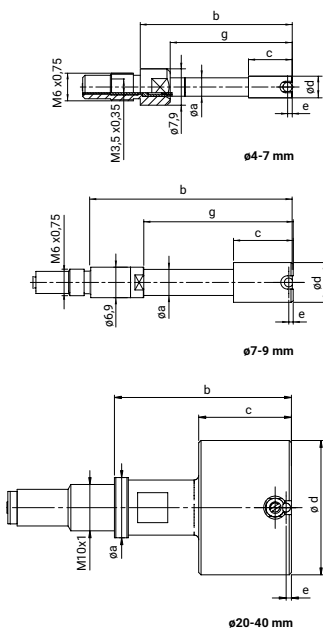

Marameter 844 D-C

Indicating plug gage

FEATURES

- Measuring probe made of hardened, stainless guide cylinder and carbide tipped probes
- Carbide driving needle transfers radial measuring movement to the display unit
- Constant measuring force as a result of built-in spring, eliminating user influence
- Measuring head, measuring instrument holder, depth extensions, right angle attachments and depth stops form a comprehensive modular system

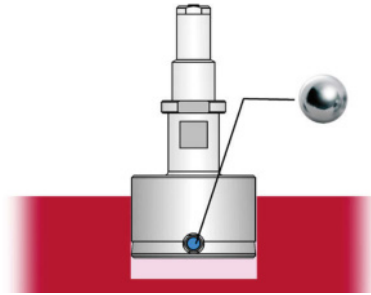

Application:

Standard model, measuring surfaces hard chrome-plated

- Preferred application on sensitive surfaces of non-ferrous metals and aluminium alloys
- For rapid testing of diameter, roundness and conicity of bores
- Especially suitable for testing batches with tight tolerance zones
- Rocking in the bore is unnecessary to determine the reversal point
- Ideal for use in conjunction with digital display units and for subsequent processing of measured values

TECHNICAL DATA

| Order no. | Type | Measuring range | Measuring span | Manufacturing tolerance | Linearity deviation | Repeatability f_w | a | b | c | e | g | Connection thread |
|-----------|---------|-----------------|----------------|-------------------------|---------------------------|---------------------|------|------|----|-----|----|-------------------|
| | | mm | mm | mm / mm | | μm | mm | mm | mm | mm | mm | |
| 4484100 | 844 D-C | 8–9 | 0.2 | -0.015 / -0.025 | 1 %, min. 1 μm | 1 | 5.7 | 47 | 15 | 2.5 | 35 | M6 x 0.75 |
| 4484101 | 844 D-C | >9–12 | 0.2 | -0.015 / -0.025 | 1 %, min. 1 μm | 1 | 7.9 | 47 | 15 | 2.5 | 47 | M6 x 0.75 |
| 4484102 | 844 D-C | >12–13 | 0.2 | -0.015 / -0.025 | 1 %, min. 1 μm | 1 | 7.9 | 47 | 15 | 2.5 | 47 | M6 x 0.75 |
| 4484103 | 844 D-C | >13–16 | 0.2 | -0.015 / -0.025 | 1 %, min. 1 μm | 1 | 11.9 | 47 | 15 | 2.5 | 47 | M6 x 0.75 |
| 4484104 | 844 D-C | >16–20 | 0.2 | -0.015 / -0.025 | 1 %, min. 1 μm | 1 | 15 | 37.3 | 15 | 2.5 | | M10x1 |
| 4484105 | 844 D-C | >20–30 | 0.2 | -0.02 / -0.03 | 1 %, min. 1 μm | 1 | 15 | 38.2 | 20 | 3.5 | | M10x1 |
| 4484106 | 844 D-C | >30–40 | 0.2 | -0.02 / -0.03 | 1 %, min. 1 μm | 1 | 15 | 38.2 | 20 | 3.5 | | M10x1 |
| 4484107 | 844 D-C | >40–60 | 0.2 | -0.02 / -0.03 | 1 %, min. 1 μm | 1 | 15 | 38.2 | 28 | 3.5 | | M10x1 |
| 4484108 | 844 D-C | >60–80 | 0.2 | -0.025 / -0.035 | 1 %, min. 1 μm | 1 | 17.9 | 38.8 | 33 | 4 | | M10x1 |
| 4484109 | 844 D-C | >80–100 | 0.2 | -0.025 / -0.035 | 1 %, min. 1 μm | 1 | 17.9 | 38.8 | 33 | 4 | | M10x1 |
| 4484110 | 844 D-C | >100–110 | 0.2 | -0.025 / -0.035 | 1 %, min. 1 μm | 1 | 17.9 | 38.8 | 33 | 4 | | M10x1 |
| 4484111 | 844 D-C | >110–120 | 0.2 | -0.025 / -0.035 | 1 %, min. 1 μm | 1 | 17.9 | 38.8 | 33 | 4 | | M10x1 |
| 4484112 | 844 D-C | >120–130 | 0.2 | -0.025 / -0.035 | 1 %, min. 1 μm | 1 | 17.9 | 38.8 | 33 | 4 | | M10x1 |
| 4484113 | 844 D-C | >130–140 | 0.2 | -0.035 / -0.045 | 1 %, min. 1 μm | 1 | 17.9 | 38.8 | 33 | 4 | | M10x1 |
| 4484114 | 844 D-C | >140–150 | 0.2 | -0.035 / -0.045 | 1 %, min. 1 μm | 1 | 17.9 | 38.8 | 33 | 4 | | M10x1 |
| 4484115 | 844 D-C | >150–160 | 0.2 | -0.035 / -0.045 | 1 %, min. 1 μm | 1 | 17.9 | 38.8 | 33 | 4 | | M10x1 |
| 4484116 | 844 D-C | >160–170 | 0.2 | -0.035 / -0.045 | 1 %, min. 1 μm | 1 | 17.9 | 39 | 40 | 4 | | M10x1 |
| 4484117 | 844 D-C | >170–180 | 0.2 | -0.035 / -0.045 | 1 %, min. 1 μm | 1 | 17.9 | 39 | 40 | 4 | | M10x1 |
| 4484118 | 844 D-C | >180–190 | 0.2 | -0.035 / -0.045 | 1 %, min. 1 μm | 1 | 17.9 | 39 | 40 | 4 | | M10x1 |
| 4484119 | 844 D-C | >190–200 | 0.2 | -0.035 / -0.045 | 1 %, min. 1 μm | 1 | 17.9 | 39 | 40 | 4 | | M10x1 |

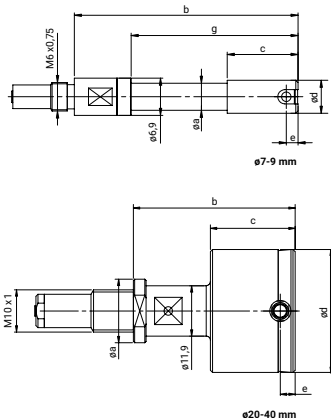

Marameter 844 DR-C

Indicating plug gage

FEATURES

- Measuring probe made of hardened, stainless guide cylinder and carbide tipped probes
- Carbide driving needle transfers radial measuring movement to the display unit
- Constant measuring force as a result of built-in spring, eliminating user influence
- Measuring head, measuring instrument holder, depth extensions, right angle attachments and depth stops form a comprehensive modular system

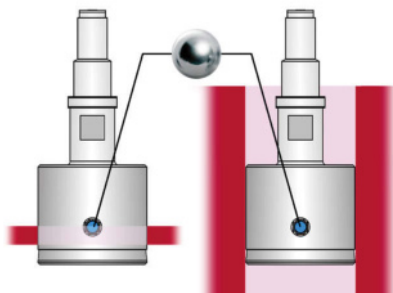

Application:

Design for through-holes, hard chrome plated measuring surfaces

- Preferred use on sensitive surfaces of non-ferrous metals and aluminum alloys
- With extended guide cylinder for measuring through holes from the edge of the hole
- For the rapid testing of diameter, roundness and conicity of bores
- Especially suitable for testing batches with tight tolerance fields
- No rocking in the bore is necessary to determine the reversal point
- Ideal for use in conjunction with digital display units and for subsequent processing of measured values

TECHNICAL DATA

| Order no. | Type | Measuring range | Measuring span | Manufacturing tolerance | Linearity deviation | Repeatability f_w | a | b | c | e | g | Connection thread |
|-----------|----------|-----------------|----------------|-------------------------|---------------------------|---------------------|------|------|------|----|------|-------------------|
| | | mm | mm | mm / mm | | μm | mm | mm | mm | mm | mm | |
| 4484130 | 844 DR-C | 8–9 | 0.2 | -0.015 / -0.025 | 1 %, min. 1 μm | 1 | 5.7 | 50.5 | 18.5 | 6 | 38.5 | M6 x 0.75 |
| 4484131 | 844 DR-C | >9–12 | 0.2 | -0.015 / -0.025 | 1 %, min. 1 μm | 1 | 7.9 | 54.5 | 22.5 | 10 | 54.5 | M6 x 0.75 |
| 4484132 | 844 DR-C | >12–13 | 0.2 | -0.015 / -0.025 | 1 %, min. 1 μm | 1 | 7.9 | 54.5 | 22.5 | 10 | 54.5 | M6 x 0.75 |
| 4484133 | 844 DR-C | >13–16 | 0.2 | -0.015 / -0.025 | 1 %, min. 1 μm | 1 | 11.9 | 54.5 | 22.5 | 10 | 54.5 | M6 x 0.75 |
| 4484134 | 844 DR-C | >16–20 | 0.2 | -0.015 / -0.025 | 1 %, min. 1 μm | 1 | 15 | 44.8 | 22.5 | 10 | | M10x1 |
| 4484135 | 844 DR-C | >20–30 | 0.2 | -0.02 / -0.03 | 1 %, min. 1 μm | 1 | 15 | 44.7 | 27 | 10 | | M10x1 |
| 4484136 | 844 DR-C | >30–40 | 0.2 | -0.02 / -0.03 | 1 %, min. 1 μm | 1 | 15 | 44.7 | 27 | 10 | | M10x1 |
| 4484137 | 844 DR-C | >40–60 | 0.2 | -0.02 / -0.03 | 1 %, min. 1 μm | 1 | 15 | 44.7 | 28 | 10 | | M10x1 |
| 4484138 | 844 DR-C | >60–80 | 0.2 | -0.025 / -0.035 | 1 %, min. 1 μm | 1 | 17.9 | 44.8 | 33 | 10 | | M10x1 |
| 4484139 | 844 DR-C | >80–100 | 0.2 | -0.025 / -0.035 | 1 %, min. 1 μm | 1 | 17.9 | 44.8 | 33 | 10 | | M10x1 |
| 4484140 | 844 DR-C | >100–110 | 0.2 | -0.025 / -0.035 | 1 %, min. 1 μm | 1 | 17.9 | 44.8 | 33 | 10 | | M10x1 |
| 4484141 | 844 DR-C | >110–120 | 0.2 | -0.025 / -0.035 | 1 %, min. 1 μm | 1 | 17.9 | 44.8 | 33 | 10 | | M10x1 |
| 4484142 | 844 DR-C | >120–130 | 0.2 | -0.025 / -0.035 | 1 %, min. 1 μm | 1 | 17.9 | 44.8 | 33 | 10 | | M10x1 |
| 4484143 | 844 DR-C | >130–140 | 0.2 | -0.035 / -0.045 | 1 %, min. 1 μm | 1 | 17.9 | 44.8 | 33 | 10 | | M10x1 |
| 4484144 | 844 DR-C | >140–150 | 0.2 | -0.035 / -0.045 | 1 %, min. 1 μm | 1 | 17.9 | 44.8 | 33 | 10 | | M10x1 |
| 4484145 | 844 DR-C | >150–160 | 0.2 | -0.035 / -0.045 | 1 %, min. 1 μm | 1 | 17.9 | 44.8 | 33 | 10 | | M10x1 |
| 4484146 | 844 DR-C | >160–170 | 0.2 | -0.035 / -0.045 | 1 %, min. 1 μm | 1 | 17.9 | 45 | 40 | 10 | | M10x1 |
| 4484147 | 844 DR-C | >170–180 | 0.2 | -0.035 / -0.045 | 1 %, min. 1 μm | 1 | 17.9 | 45 | 40 | 10 | | M10x1 |
| 4484148 | 844 DR-C | >180–190 | 0.2 | -0.035 / -0.045 | 1 %, min. 1 μm | 1 | 17.9 | 45 | 40 | 10 | | M10x1 |
| 4484149 | 844 DR-C | >190–200 | 0.2 | -0.035 / -0.045 | 1 %, min. 1 μm | 1 | 17.9 | 45 | 40 | 10 | | M10x1 |

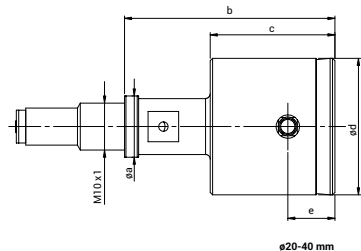
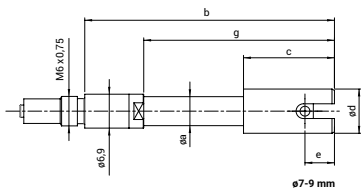

Marameter 844 DS-C

Indicating plug gage

FEATURES

- Measuring probe made of hardened, stainless guide cylinder and carbide tipped probes
- Carbide driving needle transfers radial measuring movement to the display unit
- Constant measuring force as a result of built-in spring, eliminating user influence
- Measuring head, measuring instrument holder, depth extensions, right angle attachments and depth stops form a comprehensive modular system

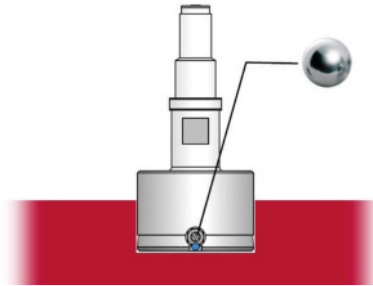

Application:

Model for blind holes, measuring surfaces hard chrome-plated

- Preferred application on sensitive surfaces of non-ferrous metals and aluminium alloys
- For measurements close to the base of the hole
- For rapid testing of diameter, roundness and conicity of bores
- Especially suitable for testing batches with tight tolerance zones
- Rocking in the bore is unnecessary to determine the reversal point
- Ideal for use in conjunction with digital display units and for subsequent processing of measured values

TECHNICAL DATA

| Order no. | Type | Measuring range | Measuring span | Manufacturing tolerance | Linearity deviation | Repeatability f_w | a | b | c | e | g | Connection thread |
|-----------|----------|-----------------|----------------|-------------------------|-----------------------------|---------------------|------|------|------|-----|------|-------------------|
| | | mm | mm | mm / mm | | μm | mm | mm | mm | mm | mm | |
| 4484160 | 844 DS-C | 8–9 | 0.2 | -0.015 / -0.025 | 1.5 %, min. 1 μm | 1 | 5.7 | 45.5 | 13.5 | 1 | 33.5 | M6 x 0.75 |
| 4484161 | 844 DS-C | >9–12 | 0.2 | -0.015 / -0.025 | 1.5 %, min. 1 μm | 1 | 7.9 | 45.5 | 13.5 | 1 | 45.5 | M6 x 0.75 |
| 4484162 | 844 DS-C | >12–13 | 0.2 | -0.015 / -0.025 | 1.5 %, min. 1 μm | 1 | 7.9 | 45.5 | 13.5 | 1 | 45.5 | M6 x 0.75 |
| 4484163 | 844 DS-C | >13–16 | 0.2 | -0.015 / -0.025 | 1.5 %, min. 1 μm | 1 | 11.9 | 45.5 | 13.5 | 1 | 45.5 | M6 x 0.75 |
| 4484164 | 844 DS-C | >16–20 | 0.2 | -0.015 / -0.025 | 1.5 %, min. 1 μm | 1 | 15 | 35.8 | 13.5 | 1 | | M10x1 |
| 4484165 | 844 DS-C | >20–30 | 0.2 | -0.02 / -0.03 | 1.5 %, min. 1 μm | 1 | 15 | 38.2 | 20 | 1.2 | | M10x1 |
| 4484166 | 844 DS-C | >30–40 | 0.2 | -0.02 / -0.03 | 1.5 %, min. 1 μm | 1 | 15 | 38.2 | 20 | 1.2 | | M10x1 |
| 4484167 | 844 DS-C | >40–60 | 0.2 | -0.02 / -0.03 | 1.5 %, min. 1 μm | 1 | 15 | 38.2 | 28 | 1.2 | | M10x1 |
| 4484168 | 844 DS-C | >60–80 | 0.2 | -0.025 / -0.035 | 1.5 %, min. 1 μm | 1 | 17.9 | 39 | 33 | 1.2 | | M10x1 |
| 4484169 | 844 DS-C | >80–100 | 0.2 | -0.025 / -0.035 | 1.5 %, min. 1 μm | 1 | 17.9 | 39 | 33 | 1.2 | | M10x1 |
| 4484170 | 844 DS-C | >100–110 | 0.2 | -0.025 / -0.035 | 1.5 %, min. 1 μm | 1 | 17.9 | 39 | 33 | 1.2 | | M10x1 |
| 4484171 | 844 DS-C | >110–120 | 0.2 | -0.025 / -0.035 | 1.5 %, min. 1 μm | 1 | 17.9 | 39 | 33 | 1.2 | | M10x1 |
| 4484172 | 844 DS-C | >120–130 | 0.2 | -0.025 / -0.035 | 1.5 %, min. 1 μm | 1 | 17.9 | 39 | 33 | 1.2 | | M10x1 |
| 4484173 | 844 DS-C | >130–140 | 0.2 | -0.035 / -0.045 | 1.5 %, min. 1 μm | 1 | 17.9 | 39 | 33 | 1.2 | | M10x1 |
| 4484174 | 844 DS-C | >140–150 | 0.2 | -0.035 / -0.045 | 1.5 %, min. 1 μm | 1 | 17.9 | 39 | 33 | 1.2 | | M10x1 |
| 4484175 | 844 DS-C | >150–160 | 0.2 | -0.035 / -0.045 | 1.5 %, min. 1 μm | 1 | 17.9 | 39 | 33 | 1.2 | | M10x1 |
| 4484176 | 844 DS-C | >160–170 | 0.2 | -0.035 / -0.045 | 1.5 %, min. 1 μm | 1 | 17.9 | 38.6 | 40 | 1.2 | | M10x1 |
| 4484177 | 844 DS-C | >170–180 | 0.2 | -0.035 / -0.045 | 1.5 %, min. 1 μm | 1 | 17.9 | 38.6 | 40 | 1.2 | | M10x1 |
| 4484178 | 844 DS-C | >180–190 | 0.2 | -0.035 / -0.045 | 1.5 %, min. 1 μm | 1 | 17.9 | 38.6 | 40 | 1.2 | | M10x1 |
| 4484179 | 844 DS-C | >190–200 | 0.2 | -0.035 / -0.045 | 1.5 %, min. 1 μm | 1 | 17.9 | 38.6 | 40 | 1.2 | | M10x1 |

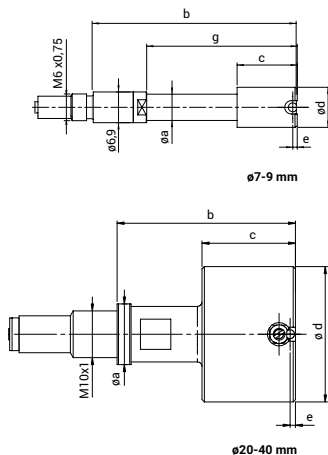

Marameter 844 D-R

Indicating plug gage

FEATURES

- Measuring probe made of hardened, stainless guide cylinder and ruby-tipped probes
- Carbide driving needle transfers radial measuring movement to the display unit
- Constant measuring force as a result of built-in spring, eliminating user influence
- Measuring head, measuring instrument holder, depth extensions, right angle attachments and depth stops form a comprehensive modular system

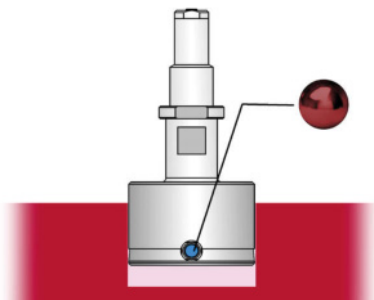

Application:
Standard model, measuring surfaces ruby-tipped

- Preferred application on sensitive surfaces of non-ferrous metals and aluminium alloys
- For rapid testing of diameter, roundness and conicity of bores
- Especially suitable for testing batches with tight tolerance zones
- Rocking in the bore is not required to determine diameter
- Ideal for use in conjunction with digital display units and for subsequent processing of measured values

TECHNICAL DATA

| Order no. | Type | Measuring range | Measuring span | Manufacturing tolerance | Linearity deviation | Repeatability f_w | a | b | c | e | g | Connection thread |
|-----------|---------|-----------------|----------------|-------------------------|---------------------------|---------------------|------|------|----|-----|----|-----------------------|
| | | mm | mm | mm / mm | | μm | mm | mm | mm | mm | mm | |
| 4484208 | 844 D-R | 3–4 | 0.2 | -0.015 / -0.025 | 1 %, min. 1 μm | 1 | | 33.5 | 24 | 1.5 | 24 | M6 x 0.75 / M3.5x0.35 |
| 4484209 | 844 D-R | >4–7 | 0.2 | -0.015 / -0.025 | 1 %, min. 1 μm | 1 | 4 | 33.5 | 10 | 1.5 | 27 | M6 x 0.75 / M3.5x0.35 |
| 4484210 | 844 D-R | >7–9 | 0.2 | -0.015 / -0.025 | 1 %, min. 1 μm | 1 | 6.9 | 47 | 15 | 2.5 | 35 | M6 x 0.75 |
| 4484211 | 844 D-R | >9–12 | 0.2 | -0.015 / -0.025 | 1 %, min. 1 μm | 1 | 7.9 | 47 | 15 | 2.5 | 47 | M6 x 0.75 |
| 4484212 | 844 D-R | >12–13 | 0.2 | -0.015 / -0.025 | 1 %, min. 1 μm | 1 | 7.9 | 47 | 15 | 2.5 | 47 | M6 x 0.75 |
| 4484213 | 844 D-R | >13–16 | 0.2 | -0.015 / -0.025 | 1 %, min. 1 μm | 1 | 11.9 | 47 | 15 | 2.5 | 47 | M6 x 0.75 |
| 4484214 | 844 D-R | >16–20 | 0.2 | -0.015 / -0.025 | 1 %, min. 1 μm | 1 | 15 | 37.3 | 15 | 2.5 | | M10x1 |
| 4484215 | 844 D-R | >20–30 | 0.2 | -0.02 / -0.03 | 1 %, min. 1 μm | 1 | 15 | 38.2 | 20 | 3.5 | | M10x1 |
| 4484216 | 844 D-R | >30–40 | 0.2 | -0.02 / -0.03 | 1 %, min. 1 μm | 1 | 15 | 38.2 | 20 | 3.5 | | M10x1 |
| 4484217 | 844 D-R | >40–60 | 0.2 | -0.02 / -0.03 | 1 %, min. 1 μm | 1 | 15 | 38.2 | 28 | 3.5 | | M10x1 |
| 4484218 | 844 D-R | >60–80 | 0.2 | -0.025 / -0.035 | 1 %, min. 1 μm | 1 | 17.9 | 38.8 | 33 | 4 | | M10x1 |
| 4484219 | 844 D-R | >80–100 | 0.2 | -0.025 / -0.035 | 1 %, min. 1 μm | 1 | 17.9 | 38.8 | 33 | 4 | | M10x1 |
| 4484220 | 844 D-R | >100–110 | 0.2 | -0.025 / -0.035 | 1 %, min. 1 μm | 1 | 17.9 | 38.8 | 33 | 4 | | M10x1 |
| 4484221 | 844 D-R | >110–120 | 0.2 | -0.025 / -0.035 | 1 %, min. 1 μm | 1 | 17.9 | 38.8 | 33 | 4 | | M10x1 |
| 4484222 | 844 D-R | >120–130 | 0.2 | -0.025 / -0.035 | 1 %, min. 1 μm | 1 | 17.9 | 38.8 | 33 | 4 | | M10x1 |
| 4484223 | 844 D-R | >130–140 | 0.2 | -0.035 / -0.045 | 1 %, min. 1 μm | 1 | 17.9 | 38.8 | 33 | 4 | | M10x1 |
| 4484224 | 844 D-R | >140–150 | 0.2 | -0.035 / -0.045 | 1 %, min. 1 μm | 1 | 17.9 | 38.8 | 33 | 4 | | M10x1 |
| 4484225 | 844 D-R | >150–160 | 0.2 | -0.035 / -0.045 | 1 %, min. 1 μm | 1 | 17.9 | 38.8 | 33 | 4 | | M10x1 |
| 4484226 | 844 D-R | >160–170 | 0.2 | -0.035 / -0.045 | 1 %, min. 1 μm | 1 | 17.9 | 39 | 40 | 4 | | M10x1 |
| 4484227 | 844 D-R | >170–180 | 0.2 | -0.035 / -0.045 | 1 %, min. 1 μm | 1 | 17.9 | 39 | 40 | 4 | | M10x1 |
| 4484228 | 844 D-R | >180–190 | 0.2 | -0.035 / -0.045 | 1 %, min. 1 μm | 1 | 17.9 | 39 | 40 | 4 | | M10x1 |
| 4484229 | 844 D-R | >190–200 | 0.2 | -0.035 / -0.045 | 1 %, min. 1 μm | 1 | 17.9 | 39 | 40 | 4 | | M10x1 |

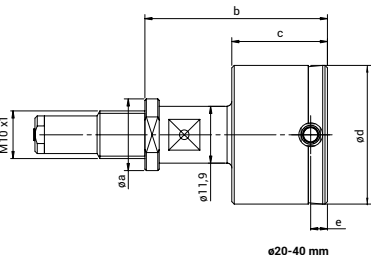
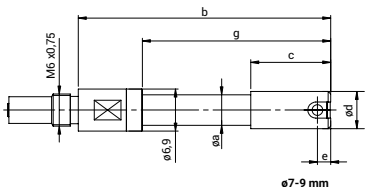
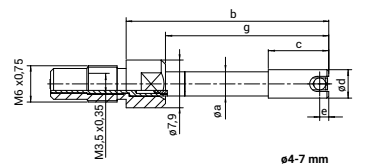

Marameter 844 DR-R

Indicating plug gage

FEATURES

- Measuring probe made of hardened, stainless guide cylinder and ruby-tipped probes
- Carbide driving needle transfers radial measuring movement to the display unit
- Constant measuring force as a result of built-in spring, eliminating user influence
- Measuring head, measuring instrument holder, depth extensions, right angle attachments and depth stops form a comprehensive modular system

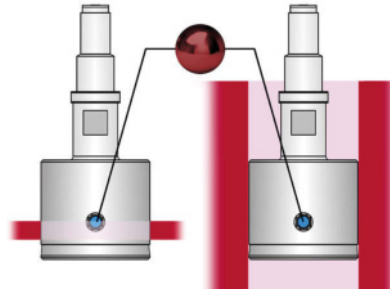

Application:

Design for through-holes, ruby-tipped measuring surfaces

- Preferred use on sensitive surfaces of non-ferrous metals and aluminum alloys
- With extended guide cylinder for measuring through holes from the edge of the hole
- For the rapid testing of diameter, roundness and conicity of bores
- Especially suitable for testing batches with tight tolerance fields
- Rocking in the bore is not required to determine diameter
- Ideal for use in conjunction with digital display units and for subsequent processing of measured values

TECHNICAL DATA

| Order no. | Type | Measuring range | Measuring span | Manufacturing tolerance | Linearity deviation | Repeatability f_w | a | b | c | e | g | Connection thread |
|-----------|----------|-----------------|----------------|-------------------------|---------------------------|---------------------|------|------|------|----|------|-----------------------|
| | | mm | mm | mm / mm | | μm | mm | mm | mm | mm | mm | |
| 4484239 | 844 DR-R | 4-7 | 0.2 | -0.015 / -0.025 | 1 %, min. 1 μm | 1 | 4 | 38 | 14.5 | 6 | 31.5 | M6 x 0.75 / M3.5x0.35 |
| 4484240 | 844 DR-R | >7-9 | 0.2 | -0.015 / -0.025 | 1 %, min. 1 μm | 1 | 6.9 | 50.5 | 18.5 | 6 | 38.5 | M6 x 0.75 |
| 4484241 | 844 DR-R | >9-12 | 0.2 | -0.015 / -0.025 | 1 %, min. 1 μm | 1 | 7.9 | 54.5 | 22.5 | 10 | 54.5 | M6 x 0.75 |
| 4484242 | 844 DR-R | >12-13 | 0.2 | -0.015 / -0.025 | 1 %, min. 1 μm | 1 | 7.9 | 54.5 | 22.5 | 10 | 54.5 | M6 x 0.75 |
| 4484243 | 844 DR-R | >13-16 | 0.2 | -0.015 / -0.025 | 1 %, min. 1 μm | 1 | 11.9 | 54.5 | 22.5 | 10 | 54.5 | M6 x 0.75 |
| 4484244 | 844 DR-R | >16-20 | 0.2 | -0.015 / -0.025 | 1 %, min. 1 μm | 1 | 15 | 44.8 | 22.5 | 10 | | M10x1 |
| 4484245 | 844 DR-R | >20-30 | 0.2 | -0.02 / -0.03 | 1 %, min. 1 μm | 1 | 15 | 44.7 | 27 | 10 | | M10x1 |
| 4484246 | 844 DR-R | >30-40 | 0.2 | -0.02 / -0.03 | 1 %, min. 1 μm | 1 | 15 | 44.7 | 27 | 10 | | M10x1 |
| 4484247 | 844 DR-R | >40-60 | 0.2 | -0.02 / -0.03 | 1 %, min. 1 μm | 1 | 15 | 44.7 | 28 | 10 | | M10x1 |
| 4484248 | 844 DR-R | >60-80 | 0.2 | -0.025 / -0.035 | 1 %, min. 1 μm | 1 | 17.9 | 44.8 | 33 | 10 | | M10x1 |
| 4484249 | 844 DR-R | >80-100 | 0.2 | -0.025 / -0.035 | 1 %, min. 1 μm | 1 | 17.9 | 44.8 | 33 | 10 | | M10x1 |
| 4484250 | 844 DR-R | >100-110 | 0.2 | -0.025 / -0.035 | 1 %, min. 1 μm | 1 | 17.9 | 44.8 | 33 | 10 | | M10x1 |
| 4484251 | 844 DR-R | >110-120 | 0.2 | -0.025 / -0.035 | 1 %, min. 1 μm | 1 | 17.9 | 44.8 | 33 | 10 | | M10x1 |
| 4484252 | 844 DR-R | >120-130 | 0.2 | -0.025 / -0.035 | 1 %, min. 1 μm | 1 | 17.9 | 44.8 | 33 | 10 | | M10x1 |
| 4484253 | 844 DR-R | >130-140 | 0.2 | -0.035 / -0.045 | 1 %, min. 1 μm | 1 | 17.9 | 44.8 | 33 | 10 | | M10x1 |
| 4484254 | 844 DR-R | >140-150 | 0.2 | -0.035 / -0.045 | 1 %, min. 1 μm | 1 | 17.9 | 44.8 | 33 | 10 | | M10x1 |
| 4484255 | 844 DR-R | >150-160 | 0.2 | -0.035 / -0.045 | 1 %, min. 1 μm | 1 | 17.9 | 44.8 | 33 | 10 | | M10x1 |
| 4484256 | 844 DR-R | >160-170 | 0.2 | -0.035 / -0.045 | 1 %, min. 1 μm | 1 | 17.9 | 45 | 40 | 10 | | M10x1 |
| 4484257 | 844 DR-R | >170-180 | 0.2 | -0.035 / -0.045 | 1 %, min. 1 μm | 1 | 17.9 | 45 | 40 | 10 | | M10x1 |
| 4484258 | 844 DR-R | >180-190 | 0.2 | -0.035 / -0.045 | 1 %, min. 1 μm | 1 | 17.9 | 45 | 40 | 10 | | M10x1 |
| 4484259 | 844 DR-R | >190-200 | 0.2 | -0.035 / -0.045 | 1 %, min. 1 μm | 1 | 17.9 | 45 | 40 | 10 | | M10x1 |

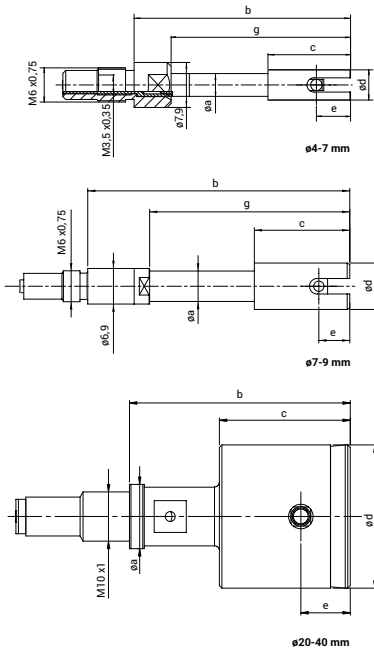

Marameter 844 DS-R

Indicating plug gage

FEATURES

- Measuring probe made of hardened, stainless guide cylinder and ruby-tipped probes
- Carbide driving needle transfers radial measuring movement to the display unit
- Constant measuring force as a result of built-in spring, eliminating user influence
- Measuring head, measuring instrument holder, depth extensions, right angle attachments and depth stops form a comprehensive modular system

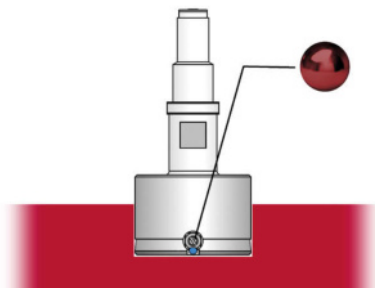

Application:

Model for blind holes, measuring surfaces ruby-tipped

- Preferred application on sensitive surfaces of non-ferrous metals and aluminium alloys
- For measurements close to the base of the hole
- For rapid testing of diameter, roundness and conicity of bores
- Especially suitable for testing batches with tight tolerance zones
- Rocking in the bore is not required to determine diameter
- Ideal for use in conjunction with digital display units and for subsequent processing of measured values

TECHNICAL DATA

| Order no. | Type | Measuring range | Measuring span | Manufacturing tolerance | Linearity deviation | Repeatability f_w | a | b | c | e | g | Connection thread |
|-----------|----------|-----------------|----------------|-------------------------|-----------------------------|---------------------|------|------|------|-----|------|-----------------------|
| | | mm | mm | mm / mm | | μm | mm | mm | mm | mm | mm | |
| 4484268 | 844 DS-R | 3-4 | 0.2 | -0.015 / -0.025 | 1.5 %, min. 1 μm | 1 | | 33 | 23.5 | 1 | 23.5 | M6 x 0.75 / M3.5x0.35 |
| 4484269 | 844 DS-R | >4-7 | 0.2 | -0.015 / -0.025 | 1.5 %, min. 1 μm | 1 | 4 | 33 | 9.5 | 1 | 26.5 | M6 x 0.75 / M3.5x0.35 |
| 4484270 | 844 DS-R | >7-9 | 0.2 | -0.015 / -0.025 | 1.5 %, min. 1 μm | 1 | 6.9 | 45.5 | 13.5 | 1 | 33.5 | M6 x 0.75 |
| 4484271 | 844 DS-R | >9-12 | 0.2 | -0.015 / -0.025 | 1.5 %, min. 1 μm | 1 | 7.9 | 45.5 | 13.5 | 1 | 45.5 | M6 x 0.75 |
| 4484272 | 844 DS-R | >12-13 | 0.2 | -0.015 / -0.025 | 1.5 %, min. 1 μm | 1 | 7.9 | 45.5 | 13.5 | 1 | 45.5 | M6 x 0.75 |
| 4484273 | 844 DS-R | >13-16 | 0.2 | -0.015 / -0.025 | 1.5 %, min. 1 μm | 1 | 11.9 | 45.5 | 13.5 | 1 | 45.5 | M6 x 0.75 |
| 4484274 | 844 DS-R | >16-20 | 0.2 | -0.015 / -0.025 | 1.5 %, min. 1 μm | 1 | 15 | 35.8 | 13.5 | 1 | | M10x1 |
| 4484275 | 844 DS-R | >20-30 | 0.2 | -0.02 / -0.03 | 1.5 %, min. 1 μm | 1 | 15 | 38.2 | 20 | 1.2 | | M10x1 |
| 4484276 | 844 DS-R | >30-40 | 0.2 | -0.02 / -0.03 | 1.5 %, min. 1 μm | 1 | 15 | 38.2 | 20 | 1.2 | | M10x1 |
| 4484277 | 844 DS-R | >40-60 | 0.2 | -0.02 / -0.03 | 1.5 %, min. 1 μm | 1 | 15 | 38.2 | 28 | 1.2 | | M10x1 |
| 4484278 | 844 DS-R | >60-80 | 0.2 | -0.025 / -0.035 | 1.5 %, min. 1 μm | 1 | 17.9 | 39 | 33 | 1.2 | | M10x1 |
| 4484279 | 844 DS-R | >80-100 | 0.2 | -0.025 / -0.035 | 1.5 %, min. 1 μm | 1 | 17.9 | 39 | 33 | 1.2 | | M10x1 |
| 4484280 | 844 DS-R | >100-110 | 0.2 | -0.025 / -0.035 | 1.5 %, min. 1 μm | 1 | 17.9 | 39 | 33 | 1.2 | | M10x1 |
| 4484281 | 844 DS-R | >110-120 | 0.2 | -0.025 / -0.035 | 1.5 %, min. 1 μm | 1 | 17.9 | 39 | 33 | 1.2 | | M10x1 |
| 4484282 | 844 DS-R | >120-130 | 0.2 | -0.025 / -0.035 | 1.5 %, min. 1 μm | 1 | 17.9 | 39 | 33 | 1.2 | | M10x1 |
| 4484283 | 844 DS-R | >130-140 | 0.2 | -0.035 / -0.045 | 1.5 %, min. 1 μm | 1 | 17.9 | 39 | 33 | 1.2 | | M10x1 |
| 4484284 | 844 DS-R | >140-150 | 0.2 | -0.035 / -0.045 | 1.5 %, min. 1 μm | 1 | 17.9 | 39 | 33 | 1.2 | | M10x1 |
| 4484285 | 844 DS-R | >150-160 | 0.2 | -0.035 / -0.045 | 1.5 %, min. 1 μm | 1 | 17.9 | 39 | 33 | 1.2 | | M10x1 |
| 4484286 | 844 DS-R | >160-170 | 0.2 | -0.035 / -0.045 | 1.5 %, min. 1 μm | 1 | 17.9 | 38.6 | 40 | 1.2 | | M10x1 |
| 4484287 | 844 DS-R | >170-180 | 0.2 | -0.035 / -0.045 | 1.5 %, min. 1 μm | 1 | 17.9 | 38.6 | 40 | 1.2 | | M10x1 |
| 4484288 | 844 DS-R | >180-190 | 0.2 | -0.035 / -0.045 | 1.5 %, min. 1 μm | 1 | 17.9 | 38.6 | 40 | 1.2 | | M10x1 |
| 4484289 | 844 DS-R | >190-200 | 0.2 | -0.035 / -0.045 | 1.5 %, min. 1 μm | 1 | 17.9 | 38.6 | 40 | 1.2 | | M10x1 |

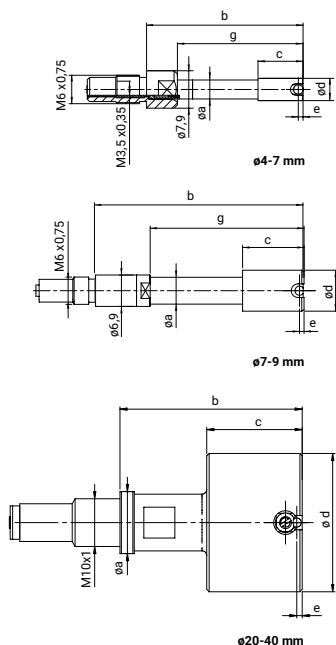

Marameter 844 D-D

Indicating plug gage

FEATURES

- Measuring probe made of hardened, stainless guide cylinder and diamond-tipped probes
- Carbide driving needle transfers radial measuring movement to the display unit
- Constant measuring force as a result of built-in spring, eliminating user influence
- Measuring head, measuring instrument holder, depth extensions, right angle attachments and depth stops form a comprehensive modular system

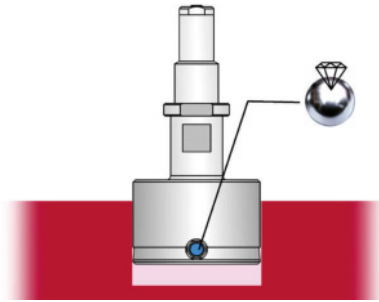

Application:

Standard model, measuring surfaces diamond-tipped

- Preferred application on very sensitive surfaces of soft non-ferrous metals and aluminium alloys
- For rapid testing of diameter, roundness and conicity of bores
- Especially suitable for testing batches with tight tolerance zones
- Rocking in the bore is not required to determine diameter
- Ideal for use in conjunction with digital display units and for subsequent processing of measured values

TECHNICAL DATA

| Order no. | Type | Measuring range | Measuring span | Manu- facturing tolerance | Linearity deviation | Repeatability f_w | a | b | c | e | g | Connection thread |
|-----------|---------|-----------------|----------------|---------------------------|---------------------------|---------------------|------|------|----|-----|----|-------------------|
| | | mm | mm | mm / mm | | μm | mm | mm | mm | mm | mm | |
| 4484300 | 844 D-D | 8–9 | 0.2 | -0.015 / -0.025 | 1 %, min. 1 μm | 1 | 5.7 | 47 | 15 | 2.5 | 35 | M6 x 0.75 |
| 4484301 | 844 D-D | >9–12 | 0.2 | -0.015 / -0.025 | 1 %, min. 1 μm | 1 | 7.9 | 47 | 15 | 2.5 | 47 | M6 x 0.75 |
| 4484302 | 844 D-D | >12–13 | 0.2 | -0.015 / -0.025 | 1 %, min. 1 μm | 1 | 7.9 | 47 | 15 | 2.5 | 47 | M6 x 0.75 |
| 4484303 | 844 D-D | >13–16 | 0.2 | -0.015 / -0.025 | 1 %, min. 1 μm | 1 | 11.9 | 47 | 15 | 2.5 | 47 | M6 x 0.75 |
| 4484304 | 844 D-D | >16–20 | 0.2 | -0.015 / -0.025 | 1 %, min. 1 μm | 1 | 15 | 37.3 | 15 | 2.5 | | M10x1 |
| 4484305 | 844 D-D | >20–30 | 0.2 | -0.02 / -0.03 | 1 %, min. 1 μm | 1 | 15 | 38.2 | 20 | 3.5 | | M10x1 |
| 4484306 | 844 D-D | >30–40 | 0.2 | -0.02 / -0.03 | 1 %, min. 1 μm | 1 | 15 | 38.2 | 20 | 3.5 | | M10x1 |
| 4484307 | 844 D-D | >40–60 | 0.2 | -0.02 / -0.03 | 1 %, min. 1 μm | 1 | 15 | 38.2 | 28 | 3.5 | | M10x1 |
| 4484308 | 844 D-D | >60–80 | 0.2 | -0.025 / -0.035 | 1 %, min. 1 μm | 1 | 17.9 | 38.8 | 33 | 4 | | M10x1 |
| 4484309 | 844 D-D | >80–100 | 0.2 | -0.025 / -0.035 | 1 %, min. 1 μm | 1 | 17.9 | 38.8 | 33 | 4 | | M10x1 |
| 4484310 | 844 D-D | >100–110 | 0.2 | -0.025 / -0.035 | 1 %, min. 1 μm | 1 | 17.9 | 38.8 | 33 | 4 | | M10x1 |
| 4484311 | 844 D-D | >110–120 | 0.2 | -0.025 / -0.035 | 1 %, min. 1 μm | 1 | 17.9 | 38.8 | 33 | 4 | | M10x1 |
| 4484312 | 844 D-D | >120–130 | 0.2 | -0.025 / -0.035 | 1 %, min. 1 μm | 1 | 17.9 | 38.8 | 33 | 4 | | M10x1 |
| 4484313 | 844 D-D | >130–140 | 0.2 | -0.035 / -0.045 | 1 %, min. 1 μm | 1 | 17.9 | 38.8 | 33 | 4 | | M10x1 |
| 4484314 | 844 D-D | >140–150 | 0.2 | -0.035 / -0.045 | 1 %, min. 1 μm | 1 | 17.9 | 38.8 | 33 | 4 | | M10x1 |
| 4484315 | 844 D-D | >150–160 | 0.2 | -0.035 / -0.045 | 1 %, min. 1 μm | 1 | 17.9 | 38.8 | 33 | 4 | | M10x1 |
| 4484316 | 844 D-D | >160–170 | 0.2 | -0.035 / -0.045 | 1 %, min. 1 μm | 1 | 17.9 | 39 | 40 | 4 | | M10x1 |
| 4484317 | 844 D-D | >170–180 | 0.2 | -0.035 / -0.045 | 1 %, min. 1 μm | 1 | 17.9 | 39 | 40 | 4 | | M10x1 |
| 4484318 | 844 D-D | >180–190 | 0.2 | -0.035 / -0.045 | 1 %, min. 1 μm | 1 | 17.9 | 39 | 40 | 4 | | M10x1 |
| 4484319 | 844 D-D | >190–200 | 0.2 | -0.035 / -0.045 | 1 %, min. 1 μm | 1 | 17.9 | 39 | 40 | 4 | | M10x1 |

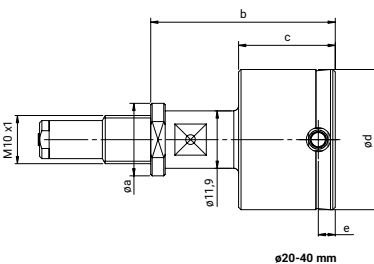
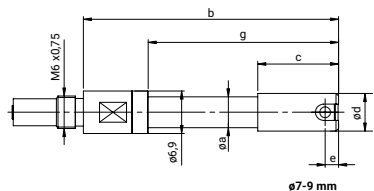

Marameter 844 DR-D

Indicating plug gage

FEATURES

- Measuring probe made of hardened, stainless guide cylinder and diamond-tipped probes
- Carbide driving needle transfers radial measuring movement to the display unit
- Constant measuring force as a result of built-in spring, eliminating user influence
- Measuring head, measuring instrument holder, depth extensions, right angle attachments and depth stops form a comprehensive modular system

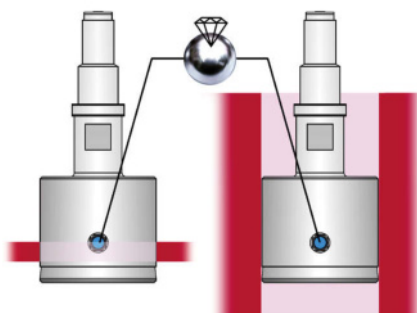

Application:

Model for through holes, measuring surfaces diamond-tipped

- Preferred application on very sensitive surfaces of soft non-ferrous metals and aluminium alloys
- With extended guide cylinder for measuring through holes from the edge of the hole
- For rapid testing of diameter, roundness and conicity of bores
- Especially suitable for testing batches with tight tolerance zones
- Rocking in the bore is not required to determine diameter
- Ideal for use in conjunction with digital display units and for subsequent processing of measured values

TECHNICAL DATA

| Order no. | Type | Measuring range | Measuring span | Manufacturing tolerance | Linearity deviation | Repeatability f_w | a | b | c | e | g | Connection thread |
|-----------|----------|-----------------|----------------|-------------------------|---------------------|---------------------|------|------|------|----|------|-------------------|
| 4484330 | 844 DR-D | 8–9 | 0.2 | -0.015 / -0.025 | 1 %, min. 1 μ m | 1 | 5.7 | 50.5 | 18.5 | 6 | 38.5 | M6 x 0.75 |
| 4484331 | 844 DR-D | >9–12 | 0.2 | -0.015 / -0.025 | 1 %, min. 1 μ m | 1 | 7.9 | 54.5 | 22.5 | 10 | 54.5 | M6 x 0.75 |
| 4484332 | 844 DR-D | >12–13 | 0.2 | -0.015 / -0.025 | 1 %, min. 1 μ m | 1 | 7.9 | 54.5 | 22.5 | 10 | 54.5 | M6 x 0.75 |
| 4484333 | 844 DR-D | >13–16 | 0.2 | -0.015 / -0.025 | 1 %, min. 1 μ m | 1 | 11.9 | 54.5 | 22.5 | 10 | 54.5 | M6 x 0.75 |
| 4484334 | 844 DR-D | >16–20 | 0.2 | -0.015 / -0.025 | 1 %, min. 1 μ m | 1 | 15 | 44.8 | 22.5 | 10 | | M10x1 |
| 4484335 | 844 DR-D | >20–30 | 0.2 | -0.02 / -0.03 | 1 %, min. 1 μ m | 1 | 15 | 44.7 | 27 | 10 | | M10x1 |
| 4484336 | 844 DR-D | >30–40 | 0.2 | -0.02 / -0.03 | 1 %, min. 1 μ m | 1 | 15 | 44.7 | 27 | 10 | | M10x1 |
| 4484337 | 844 DR-D | >40–60 | 0.2 | -0.02 / -0.03 | 1 %, min. 1 μ m | 1 | 15 | 44.7 | 28 | 10 | | M10x1 |
| 4484338 | 844 DR-D | >60–80 | 0.2 | -0.025 / -0.035 | 1 %, min. 1 μ m | 1 | 17.9 | 44.8 | 33 | 10 | | M10x1 |
| 4484339 | 844 DR-D | >80–100 | 0.2 | -0.025 / -0.035 | 1 %, min. 1 μ m | 1 | 17.9 | 44.8 | 33 | 10 | | M10x1 |
| 4484340 | 844 DR-D | >100–110 | 0.2 | -0.025 / -0.035 | 1 %, min. 1 μ m | 1 | 17.9 | 44.8 | 33 | 10 | | M10x1 |
| 4484341 | 844 DR-D | >110–120 | 0.2 | -0.025 / -0.035 | 1 %, min. 1 μ m | 1 | 17.9 | 44.8 | 33 | 10 | | M10x1 |
| 4484342 | 844 DR-D | >120–130 | 0.2 | -0.025 / -0.035 | 1 %, min. 1 μ m | 1 | 17.9 | 44.8 | 33 | 10 | | M10x1 |
| 4484343 | 844 DR-D | >130–140 | 0.2 | -0.035 / -0.045 | 1 %, min. 1 μ m | 1 | 17.9 | 44.8 | 33 | 10 | | M10x1 |
| 4484344 | 844 DR-D | >140–150 | 0.2 | -0.035 / -0.045 | 1 %, min. 1 μ m | 1 | 17.9 | 44.8 | 33 | 10 | | M10x1 |
| 4484345 | 844 DR-D | >150–160 | 0.2 | -0.035 / -0.045 | 1 %, min. 1 μ m | 1 | 17.9 | 44.8 | 33 | 10 | | M10x1 |
| 4484346 | 844 DR-D | >160–170 | 0.2 | -0.035 / -0.045 | 1 %, min. 1 μ m | 1 | 17.9 | 45 | 40 | 10 | | M10x1 |
| 4484347 | 844 DR-D | >170–180 | 0.2 | -0.035 / -0.045 | 1 %, min. 1 μ m | 1 | 17.9 | 45 | 40 | 10 | | M10x1 |
| 4484348 | 844 DR-D | >180–190 | 0.2 | -0.035 / -0.045 | 1 %, min. 1 μ m | 1 | 17.9 | 45 | 40 | 10 | | M10x1 |
| 4484349 | 844 DR-D | >190–200 | 0.2 | -0.035 / -0.045 | 1 %, min. 1 μ m | 1 | 17.9 | 45 | 40 | 10 | | M10x1 |

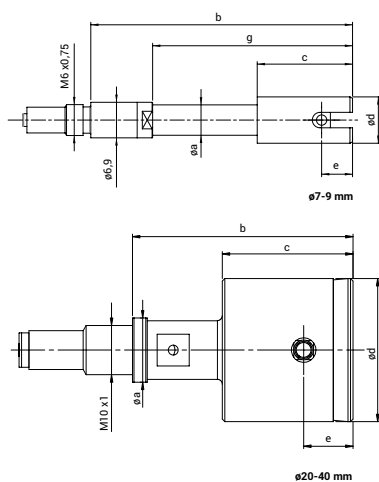

Marameter 844 D-FD

Indicating plug gage

FEATURES

- The face distance dimension "e" must be set between minimum dimension e and standard dimension - Please specify when placing an order!
- Measuring probe made of hardened, stainless guide cylinder and carbide tipped probes
- Carbide driving needle transfers radial measuring movement to the display unit
- Constant measuring force as a result of built-in spring, eliminating user influence
- Measuring head, measuring instrument holder, depth extensions, right angle attachments and depth stops form a comprehensive modular system

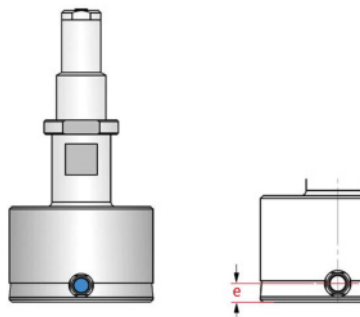

Application:

Standard version, measuring contacts with customer-specified location "e"

- Shorter guide cylinder for measuring closer to the bottom of the hole or at a defined spot
- For the rapid testing of diameter, roundness and conicity of holes
- Especially suitable for testing batches with tight tolerance fields
- Rocking in the bore is not required to determine diameter
- Ideal for use in conjunction with digital display units and for subsequent processing of measured values

TECHNICAL DATA

| Order no. | Type | Measuring range | Measuring span | Manufacturing tolerance | Linearity deviation f_e | Repeatability f_w | a | b | c | e | g | Connection thread |
|-----------|----------|-----------------|----------------|-------------------------|-----------------------------|---------------------|------|------|------|----------|------|-----------------------|
| | | mm | mm | mm / mm | | μm | mm | mm | mm | mm | mm | |
| 4484387 | 844 D-FD | 2–2,999 | 0.15 | -0.015 / -0.025 | 1.5 %, min. 1 μm | 1 | | 20.7 | 14,2 | 0.8 -1.4 | 14,2 | M6 x 0.75 / M3.5x0.35 |
| 4484388 | 844 D-FD | 3–4 | 0.2 | -0.015 / -0.025 | 1.5 %, min. 1 μm | 1 | | 33 | 23.5 | 1.1 -1.4 | 23.5 | M6 x 0.75 / M3.5x0.35 |
| 4484389 | 844 D-FD | >4–7 | 0.2 | -0.015 / -0.025 | 1.5 %, min. 1 μm | 1 | 4 | 33 | 9.5 | 1.1 -1.4 | 26.5 | M6 x 0.75 / M3.5x0.35 |
| 4484390 | 844 D-FD | >7–9 | 0.2 | -0.015 / -0.025 | 1.5 %, min. 1 μm | 1 | 6.9 | 45.5 | 13.5 | 1.1 -2.4 | 33.5 | M6 x 0.75 |
| 4484391 | 844 D-FD | >9–12 | 0.2 | -0.015 / -0.025 | 1.5 %, min. 1 μm | 1 | 7.9 | 45.5 | 13.5 | 1.1 -2.4 | 45.5 | M6 x 0.75 |
| 4484392 | 844 D-FD | >12–13 | 0.2 | -0.015 / -0.025 | 1.5 %, min. 1 μm | 1 | 7.9 | 45.5 | 13.5 | 1.1 -2.4 | 45.5 | M6 x 0.75 |
| 4484393 | 844 D-FD | >13–16 | 0.2 | -0.015 / -0.025 | 1.5 %, min. 1 μm | 1 | 11.9 | 45.5 | 13.5 | 1.1 -2.4 | 45.5 | M6 x 0.75 |
| 4484394 | 844 D-FD | >16–20 | 0.2 | -0.015 / -0.025 | 1.5 %, min. 1 μm | 1 | 15 | 35.8 | 13.5 | 1.1 -2.4 | | M10x1 |
| 4484395 | 844 D-FD | >20–30 | 0.2 | -0.02 / -0.03 | 1.5 %, min. 1 μm | 1 | 15 | 38.2 | 20 | 1.3 -3,4 | | M10x1 |
| 4484396 | 844 D-FD | >30–40 | 0.2 | -0.02 / -0.03 | 1.5 %, min. 1 μm | 1 | 15 | 38.2 | 20 | 1.3 -3,4 | | M10x1 |
| 4484397 | 844 D-FD | >40–60 | 0.2 | -0.02 / -0.03 | 1.5 %, min. 1 μm | 1 | 15 | 38.2 | 28 | 1.3 -3,4 | | M10x1 |
| 4484398 | 844 D-FD | >60–80 | 0.2 | -0.025 / -0.035 | 1.5 %, min. 1 μm | 1 | 17.9 | 39 | 33 | 1.3 -3,9 | | M10x1 |
| 4484399 | 844 D-FD | >80–100 | 0.2 | -0.025 / -0.035 | 1.5 %, min. 1 μm | 1 | 17.9 | 39 | 33 | 1.3 -3,9 | | M10x1 |
| 4484400 | 844 D-FD | >100–110 | 0.2 | -0.025 / -0.035 | 1.5 %, min. 1 μm | 1 | 17.9 | 39 | 33 | 1.3 -3,9 | | M10x1 |
| 4484401 | 844 D-FD | >110–120 | 0.2 | -0.025 / -0.035 | 1.5 %, min. 1 μm | 1 | 17.9 | 39 | 33 | 1.3 -3,9 | | M10x1 |
| 4484402 | 844 D-FD | >120–130 | 0.2 | -0.025 / -0.035 | 1.5 %, min. 1 μm | 1 | 17.9 | 39 | 33 | 1.3 -3,9 | | M10x1 |
| 4484403 | 844 D-FD | >130–140 | 0.2 | -0.035 / -0.045 | 1.5 %, min. 1 μm | 1 | 17.9 | 39 | 33 | 1.3 -3,9 | | M10x1 |
| 4484404 | 844 D-FD | >140–150 | 0.2 | -0.035 / -0.045 | 1.5 %, min. 1 μm | 1 | 17.9 | 39 | 33 | 1.3 -3,9 | | M10x1 |
| 4484405 | 844 D-FD | >150–160 | 0.2 | -0.035 / -0.045 | 1.5 %, min. 1 μm | 1 | 17.9 | 39 | 33 | 1.3 -3,9 | | M10x1 |
| 4484406 | 844 D-FD | >160–170 | 0.2 | -0.035 / -0.045 | 1.5 %, min. 1 μm | 1 | 17.9 | 38.6 | 40 | 1.3 -3,9 | | M10x1 |
| 4484407 | 844 D-FD | >170–180 | 0.2 | -0.035 / -0.045 | 1.5 %, min. 1 μm | 1 | 17.9 | 38.6 | 40 | 1.3 -3,9 | | M10x1 |
| 4484408 | 844 D-FD | >180–190 | 0.2 | -0.035 / -0.045 | 1.5 %, min. 1 μm | 1 | 17.9 | 38.6 | 40 | 1.3 -3,9 | | M10x1 |
| 4484409 | 844 D-FD | >190–200 | 0.2 | -0.035 / -0.045 | 1.5 %, min. 1 μm | 1 | 17.9 | 37 | 40 | 1.3 -3,9 | | M10x1 |

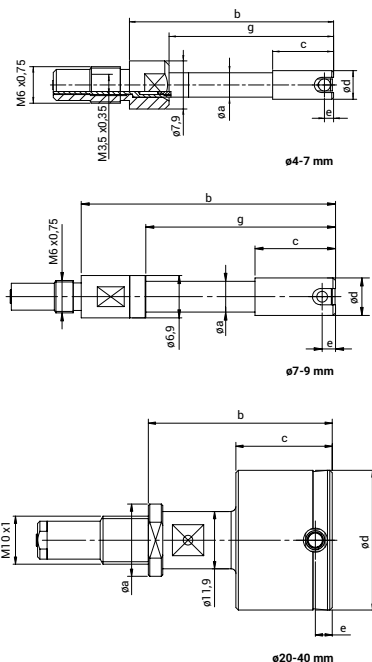

Marameter 844 DR-FD

Indicating plug gage

FEATURES

- The face distance dimension "e" must be set between minimum dimension e and standard dimension - Please specify when placing an order!
- Measuring probe made of hardened, stainless guide cylinder and carbide tipped probes
- Carbide driving needle transfers radial measuring movement to the display unit
- Constant measuring force as a result of built-in spring, eliminating user influence
- Measuring head, measuring instrument holder, depth extensions, right angle attachments and depth stops form a comprehensive modular system

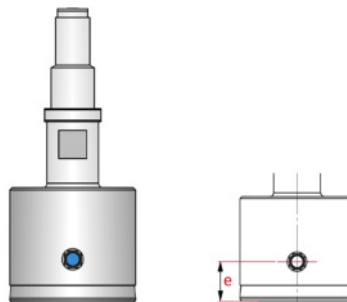

Application:

Model for through holes, anvils with customer-specified location "e"

- Reducing the guide cylinder to measure closer, or at a defined position, to the ground of the bore
- With extended guide cylinder for measuring through holes from the edge of the hole
- For rapid testing of diameter, roundness and conicity of bores
- Especially suitable for testing batches with tight tolerance zones
- Rocking in the bore is not required to determine diameter
- Ideal for use in conjunction with digital display units and for subsequent processing of measured values

TECHNICAL DATA

| Order no. | Type | Measuring range | Measuring span | Manufacturing tolerance | Linearity deviation | Repeatability f_w | a | b | c | e | g | Connection thread |
|-----------|-----------|-----------------|----------------|-------------------------|---------------------|---------------------|------|------|------|-----|------|-----------------------|
| 4484419 | 844 DR-FD | 4-7 | 0.2 | -0.015 / -0.025 | 1 %, min. 1 μ m | 1 | 4 | 38 | 14.5 | 1.6 | 31.5 | M6 x 0.75 / M3.5x0.35 |
| 4484420 | 844 DR-FD | >7-9 | 0.2 | -0.015 / -0.025 | 1 %, min. 1 μ m | 1 | 6.9 | 50.5 | 18.5 | 2.6 | 38.5 | M6 x 0.75 |
| 4484421 | 844 DR-FD | >9-12 | 0.2 | -0.015 / -0.025 | 1 %, min. 1 μ m | 1 | 7.9 | 54.5 | 22.5 | 2.6 | 54.5 | M6 x 0.75 |
| 4484422 | 844 DR-FD | >12-13 | 0.2 | -0.015 / -0.025 | 1 %, min. 1 μ m | 1 | 7.9 | 54.5 | 22.5 | 2.6 | 54.5 | M6 x 0.75 |
| 4484423 | 844 DR-FD | >13-16 | 0.2 | -0.015 / -0.025 | 1 %, min. 1 μ m | 1 | 11.9 | 54.5 | 22.5 | 2.6 | 54.5 | M6 x 0.75 |
| 4484424 | 844 DR-FD | >16-20 | 0.2 | -0.015 / -0.025 | 1 %, min. 1 μ m | 1 | 15 | 44.8 | 22.5 | 2.6 | | M10x1 |
| 4484425 | 844 DR-FD | >20-30 | 0.2 | -0.02 / -0.03 | 1 %, min. 1 μ m | 1 | 15 | 44.7 | 27 | 3.6 | | M10x1 |
| 4484426 | 844 DR-FD | >30-40 | 0.2 | -0.02 / -0.03 | 1 %, min. 1 μ m | 1 | 15 | 44.7 | 27 | 3.6 | | M10x1 |
| 4484427 | 844 DR-FD | >40-60 | 0.2 | -0.02 / -0.03 | 1 %, min. 1 μ m | 1 | 15 | 44.7 | 28 | 3.6 | | M10x1 |
| 4484428 | 844 DR-FD | >60-80 | 0.2 | -0.025 / -0.035 | 1 %, min. 1 μ m | 1 | 17.9 | 44.8 | 33 | 4.1 | | M10x1 |
| 4484429 | 844 DR-FD | >80-100 | 0.2 | -0.025 / -0.035 | 1 %, min. 1 μ m | 1 | 17.9 | 44.8 | 33 | 4.1 | | M10x1 |
| 4484430 | 844 DR-FD | >100-110 | 0.2 | -0.025 / -0.035 | 1 %, min. 1 μ m | 1 | 17.9 | 44.8 | 33 | 4.1 | | M10x1 |
| 4484431 | 844 DR-FD | >110-120 | 0.2 | -0.025 / -0.035 | 1 %, min. 1 μ m | 1 | 17.9 | 44.8 | 33 | 4.1 | | M10x1 |
| 4484432 | 844 DR-FD | >120-130 | 0.2 | -0.025 / -0.035 | 1 %, min. 1 μ m | 1 | 17.9 | 44.8 | 33 | 4.1 | | M10x1 |
| 4484433 | 844 DR-FD | >130-140 | 0.2 | -0.035 / -0.045 | 1 %, min. 1 μ m | 1 | 17.9 | 44.8 | 33 | 4.1 | | M10x1 |
| 4484434 | 844 DR-FD | >140-150 | 0.2 | -0.035 / -0.045 | 1 %, min. 1 μ m | 1 | 17.9 | 44.8 | 33 | 4.1 | | M10x1 |
| 4484435 | 844 DR-FD | >150-160 | 0.2 | -0.035 / -0.045 | 1 %, min. 1 μ m | 1 | 17.9 | 44.8 | 33 | 4.1 | | M10x1 |
| 4484436 | 844 DR-FD | >160-170 | 0.2 | -0.035 / -0.045 | 1 %, min. 1 μ m | 1 | 17.9 | 45 | 40 | 4.1 | | M10x1 |
| 4484437 | 844 DR-FD | >170-180 | 0.2 | -0.035 / -0.045 | 1 %, min. 1 μ m | 1 | 17.9 | 45 | 40 | 4.1 | | M10x1 |
| 4484438 | 844 DR-FD | >180-190 | 0.2 | -0.035 / -0.045 | 1 %, min. 1 μ m | 1 | 17.9 | 45 | 40 | 4.1 | | M10x1 |
| 4484439 | 844 DR-FD | >190-200 | 0.2 | -0.035 / -0.045 | 1 %, min. 1 μ m | 1 | 17.9 | 45 | 40 | 4.1 | | M10x1 |

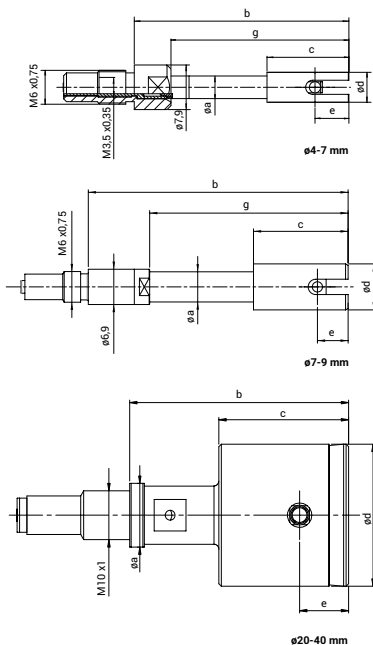

Marameter 844 D-M

Indicating plug gage

FEATURES

- Measuring probe made of hardened, stainless steel guide cylinder and carbide tipped probes
- Carbide driving needle transfers radial measuring movement to the display unit
- Constant measuring force as a result of built-in spring, eliminating user influence
- Measuring head, measuring instrument holder, depth extensions, right angle attachments and depth stops form a comprehensive modular system

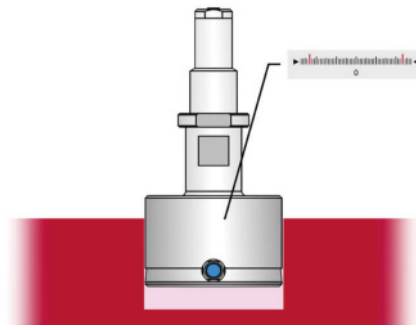

Application:

Standard model, with extended measuring range

- For rapid testing of diameter, roundness and conicity of bores
- Especially suitable for testing batches with wide tolerance zones
- Rocking in the bore is not required to determine diameter
- Ideal for use in conjunction with digital display units and for subsequent processing of measured values

TECHNICAL DATA

| Order no. | Type | Measuring range | Measuring span | Manufacturing tolerance | Linearity deviation | Repeatability f_w | a | b | c | e | g | Connection thread |
|-----------|---------|-----------------|----------------|-------------------------|---------------------------|---------------------|------|------|----|-----|----|-----------------------|
| | | mm | mm | mm / mm | | μm | mm | mm | mm | mm | mm | |
| 4484448 | 844 D-M | 3–4 | 0.4 | -0.015 / -0.025 | 1 %, min. 1 μm | 1 | | 33.5 | 24 | 1.5 | 24 | M6 x 0.75 / M3.5x0.35 |
| 4484449 | 844 D-M | >4–7 | 0.4 | -0.015 / -0.025 | 1 %, min. 1 μm | 1 | 4 | 33.5 | 10 | 1.5 | 27 | M6 x 0.75 / M3.5x0.35 |
| 4484450 | 844 D-M | >7–9 | 0.6 | -0.015 / -0.025 | 1 %, min. 1 μm | 1 | 6.9 | 47 | 15 | 2.5 | 35 | M6 x 0.75 |
| 4484451 | 844 D-M | >9–12 | 0.6 | -0.015 / -0.025 | 1 %, min. 1 μm | 1 | 7.9 | 47 | 15 | 2.5 | 47 | M6 x 0.75 |
| 4484452 | 844 D-M | >12–13 | 0.6 | -0.015 / -0.025 | 1 %, min. 1 μm | 1 | 7.9 | 47 | 15 | 2.5 | 47 | M6 x 0.75 |
| 4484453 | 844 D-M | >13–16 | 0.6 | -0.015 / -0.025 | 1 %, min. 1 μm | 1 | 11.9 | 47 | 15 | 2.5 | 47 | M6 x 0.75 |
| 4484454 | 844 D-M | >16–20 | 0.6 | -0.015 / -0.025 | 1 %, min. 1 μm | 1 | 15 | 37.3 | 15 | 2.5 | | M10x1 |
| 4484455 | 844 D-M | >20–30 | 0.6 | -0.02 / -0.03 | 1 %, min. 1 μm | 1 | 15 | 38.2 | 20 | 3.5 | | M10x1 |
| 4484456 | 844 D-M | >30–40 | 0.6 | -0.02 / -0.03 | 1 %, min. 1 μm | 1 | 15 | 38.2 | 20 | 3.5 | | M10x1 |
| 4484457 | 844 D-M | >40–60 | 0.6 | -0.02 / -0.03 | 1 %, min. 1 μm | 1 | 15 | 38.2 | 28 | 3.5 | | M10x1 |
| 4484458 | 844 D-M | >60–80 | 0.6 | -0.025 / -0.035 | 1 %, min. 1 μm | 1 | 17.9 | 38.8 | 33 | 4 | | M10x1 |
| 4484459 | 844 D-M | >80–100 | 0.6 | -0.025 / -0.035 | 1 %, min. 1 μm | 1 | 17.9 | 38.8 | 33 | 4 | | M10x1 |
| 4484460 | 844 D-M | >100–110 | 0.6 | -0.025 / -0.035 | 1 %, min. 1 μm | 1 | 17.9 | 38.8 | 33 | 4 | | M10x1 |
| 4484461 | 844 D-M | >110–120 | 0.6 | -0.025 / -0.035 | 1 %, min. 1 μm | 1 | 17.9 | 38.8 | 33 | 4 | | M10x1 |
| 4484462 | 844 D-M | >120–130 | 0.6 | -0.025 / -0.035 | 1 %, min. 1 μm | 1 | 17.9 | 38.8 | 33 | 4 | | M10x1 |
| 4484463 | 844 D-M | >130–140 | 0.6 | -0.035 / -0.045 | 1 %, min. 1 μm | 1 | 17.9 | 38.8 | 33 | 4 | | M10x1 |
| 4484464 | 844 D-M | >140–150 | 0.6 | -0.035 / -0.045 | 1 %, min. 1 μm | 1 | 17.9 | 38.8 | 33 | 4 | | M10x1 |
| 4484465 | 844 D-M | >150–160 | 0.6 | -0.035 / -0.045 | 1 %, min. 1 μm | 1 | 17.9 | 38.8 | 33 | 4 | | M10x1 |
| 4484466 | 844 D-M | >160–170 | 0.6 | -0.035 / -0.045 | 1 %, min. 1 μm | 1 | 17.9 | 39 | 40 | 4 | | M10x1 |
| 4484467 | 844 D-M | >170–180 | 0.6 | -0.035 / -0.045 | 1 %, min. 1 μm | 1 | 17.9 | 39 | 40 | 4 | | M10x1 |
| 4484468 | 844 D-M | >180–190 | 0.6 | -0.035 / -0.045 | 1 %, min. 1 μm | 1 | 17.9 | 39 | 40 | 4 | | M10x1 |
| 4484469 | 844 D-M | >190–200 | 0.6 | -0.035 / -0.045 | 1 %, min. 1 μm | 1 | 17.9 | 39 | 40 | 4 | | M10x1 |

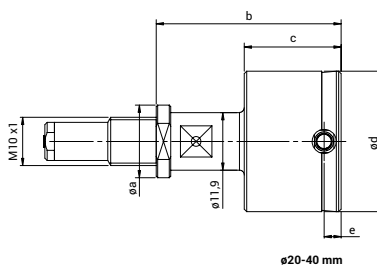
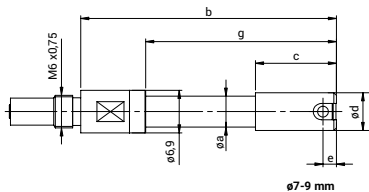
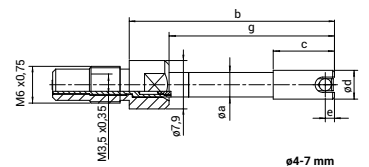

Marameter 844 DR-M

Indicating plug gage

FEATURES

- Measuring probe made of hardened, stainless guide cylinder and carbide tipped probes
- Carbide driving needle transfers radial measuring movement to the display unit
- Constant measuring force as a result of built-in spring, eliminating user influence
- Measuring head, measuring instrument holder, depth extensions, right angle attachments and depth stops form a comprehensive modular system

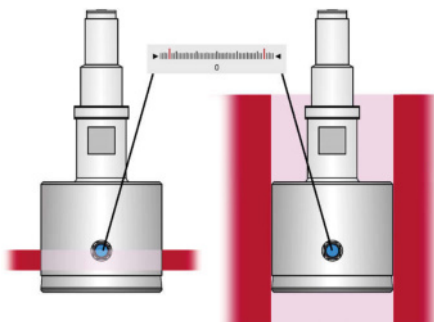

Application:

Model for through holes, with extended measuring range

- With extended guide cylinder for measuring through holes from the edge of the hole
- For the rapid testing of diameter, roundness and conicity of bores
- Especially suitable for testing batches with wide tolerance zones
- Rocking in the bore is not required to determine diameter
- Ideal for use in conjunction with digital display units and for subsequent processing of measured values

TECHNICAL DATA

| Order no. | Type | Measuring range | Measuring span | Manufacturing tolerance | Linearity deviation | Repeatability f_w | a | b | c | e | g | Connection thread |
|-----------|----------|-----------------|----------------|-------------------------|---------------------------|---------------------|------|------|------|----|------|-----------------------|
| | | mm | mm | mm / mm | | μm | mm | mm | mm | mm | mm | |
| 4484479 | 844 DR-M | 4–7 | 0.4 | -0.015 / -0.025 | 1 %, min. 1 μm | 1 | 4 | 38 | 14.5 | 6 | 31.5 | M6 x 0.75 / M3.5x0.35 |
| 4484480 | 844 DR-M | >7–9 | 0.6 | -0.015 / -0.025 | 1 %, min. 1 μm | 1 | 6.9 | 50.5 | 18.5 | 6 | 38.5 | M6 x 0.75 |
| 4484481 | 844 DR-M | >9–12 | 0.6 | -0.015 / -0.025 | 1 %, min. 1 μm | 1 | 7.9 | 54.5 | 22.5 | 10 | 54.5 | M6 x 0.75 |
| 4484482 | 844 DR-M | >12–13 | 0.6 | -0.015 / -0.025 | 1 %, min. 1 μm | 1 | 7.9 | 54.5 | 22.5 | 10 | 54.5 | M6 x 0.75 |
| 4484483 | 844 DR-M | >13–16 | 0.6 | -0.015 / -0.025 | 1 %, min. 1 μm | 1 | 11.9 | 54.5 | 22.5 | 10 | 54.5 | M6 x 0.75 |
| 4484484 | 844 DR-M | >16–20 | 0.6 | -0.015 / -0.025 | 1 %, min. 1 μm | 1 | 15 | 44.8 | 22.5 | 10 | | M10x1 |
| 4484485 | 844 DR-M | >20–30 | 0.6 | -0.02 / -0.03 | 1 %, min. 1 μm | 1 | 15 | 44.7 | 27 | 10 | | M10x1 |
| 4484486 | 844 DR-M | >30–40 | 0.6 | -0.02 / -0.03 | 1 %, min. 1 μm | 1 | 15 | 44.7 | 27 | 10 | | M10x1 |
| 4484487 | 844 DR-M | >40–60 | 0.6 | -0.02 / -0.03 | 1 %, min. 1 μm | 1 | 15 | 44.7 | 28 | 10 | | M10x1 |
| 4484488 | 844 DR-M | >60–80 | 0.6 | -0.025 / -0.035 | 1 %, min. 1 μm | 1 | 17.9 | 44.8 | 33 | 10 | | M10x1 |
| 4484489 | 844 DR-M | >80–100 | 0.6 | -0.025 / -0.035 | 1 %, min. 1 μm | 1 | 17.9 | 44.8 | 33 | 10 | | M10x1 |
| 4484490 | 844 DR-M | >100–110 | 0.6 | -0.025 / -0.035 | 1 %, min. 1 μm | 1 | 17.9 | 44.8 | 33 | 10 | | M10x1 |
| 4484491 | 844 DR-M | >110–120 | 0.6 | -0.025 / -0.035 | 1 %, min. 1 μm | 1 | 17.9 | 44.8 | 33 | 10 | | M10x1 |
| 4484492 | 844 DR-M | >120–130 | 0.6 | -0.025 / -0.035 | 1 %, min. 1 μm | 1 | 17.9 | 44.8 | 33 | 10 | | M10x1 |
| 4484493 | 844 DR-M | >130–140 | 0.6 | -0.035 / -0.045 | 1 %, min. 1 μm | 1 | 17.9 | 44.8 | 33 | 10 | | M10x1 |
| 4484494 | 844 DR-M | >140–150 | 0.6 | -0.035 / -0.045 | 1 %, min. 1 μm | 1 | 17.9 | 44.8 | 33 | 10 | | M10x1 |
| 4484495 | 844 DR-M | >150–160 | 0.6 | -0.035 / -0.045 | 1 %, min. 1 μm | 1 | 17.9 | 44.8 | 33 | 10 | | M10x1 |
| 4484496 | 844 DR-M | >160–170 | 0.6 | -0.035 / -0.045 | 1 %, min. 1 μm | 1 | 17.9 | 45 | 40 | 10 | | M10x1 |
| 4484497 | 844 DR-M | >170–180 | 0.6 | -0.035 / -0.045 | 1 %, min. 1 μm | 1 | 17.9 | 45 | 40 | 10 | | M10x1 |
| 4484498 | 844 DR-M | >180–190 | 0.6 | -0.035 / -0.045 | 1 %, min. 1 μm | 1 | 17.9 | 45 | 40 | 10 | | M10x1 |
| 4484499 | 844 DR-M | >190–200 | 0.6 | -0.035 / -0.045 | 1 %, min. 1 μm | 1 | 17.9 | 45 | 40 | 10 | | M10x1 |

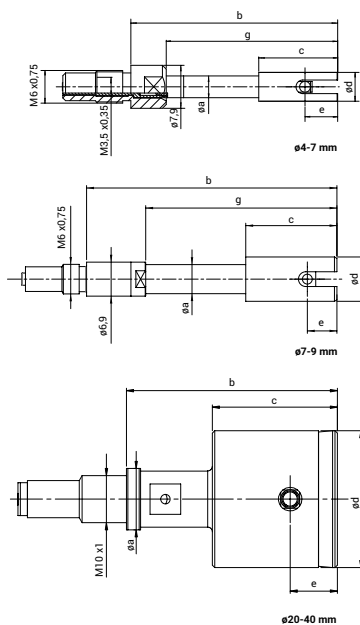

Marameter 844 DS-M

Indicating plug gage

FEATURES

- Measuring probe made of hardened, stainless steel guide cylinder and carbide tipped probes
- Carbide driving needle transfers radial measuring movement to the display unit
- Constant measuring force as a result of built-in spring, eliminating user influence
- Measuring head, measuring instrument holder, depth extensions, right angle attachments, and depth stops form a comprehensive modular system

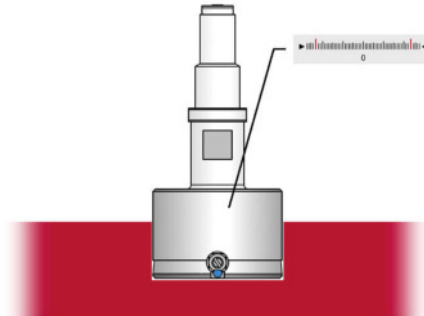

Application: Model for blind holes, with extended measuring range

Recommendation: To protect the measuring contacts when inserting them into the bore, the use of a holder with lifting device (844 Kga or 844 Dga) is recommended

- For measurements close to the base of the hole
- For the rapid testing of diameter, roundness and conicity of bores
- Especially suitable for testing batches with wide tolerance zones
- Rocking in the bore is not required to determine diameter
- Ideal for use in conjunction with digital display units and for subsequent processing of measured values

TECHNICAL DATA

| Order no. | Type | Measuring range | Measuring span | Manufacturing tolerance | Linearity deviation | Repeatability f_w | a | b | c | e | g | Connection thread |
|-----------|----------|-----------------|----------------|-------------------------|-----------------------------|---------------------|------|------|------|-----|------|-----------------------|
| | | mm | mm | mm / mm | | μm | mm | mm | mm | mm | mm | |
| 4484508 | 844 DS-M | 3–4 | 0.4 | –0.015 / –0.025 | 1.5 %, min. 1 μm | 1 | | 33 | 23.5 | 1 | 23.5 | M6 x 0.75 / M3.5x0.35 |
| 4484509 | 844 DS-M | >4–7 | 0.4 | –0.015 / –0.025 | 1.5 %, min. 1 μm | 1 | 4 | 33 | 9.5 | 1 | 26.5 | M6 x 0.75 / M3.5x0.35 |
| 4484510 | 844 DS-M | >7–9 | 0.6 | –0.015 / –0.025 | 1.5 %, min. 1 μm | 1 | 6.9 | 45.5 | 13.5 | 1 | 33.5 | M6 x 0.75 |
| 4484511 | 844 DS-M | >9–12 | 0.6 | –0.015 / –0.025 | 1.5 %, min. 1 μm | 1 | 7.9 | 45.5 | 13.5 | 1 | 45.5 | M6 x 0.75 |
| 4484512 | 844 DS-M | >12–13 | 0.6 | –0.015 / –0.025 | 1.5 %, min. 1 μm | 1 | 7.9 | 45.5 | 13.5 | 1 | 45.5 | M6 x 0.75 |
| 4484513 | 844 DS-M | >13–16 | 0.6 | –0.015 / –0.025 | 1.5 %, min. 1 μm | 1 | 11.9 | 45.5 | 13.5 | 1 | 45.5 | M6 x 0.75 |
| 4484514 | 844 DS-M | >16–20 | 0.6 | –0.015 / –0.025 | 1.5 %, min. 1 μm | 1 | 15 | 35.8 | 13.5 | 1 | | M10x1 |
| 4484515 | 844 DS-M | >20–30 | 0.6 | –0.02 / –0.03 | 1.5 %, min. 1 μm | 1 | 15 | 38.2 | 20 | 1.2 | | M10x1 |
| 4484516 | 844 DS-M | >30–40 | 0.6 | –0.02 / –0.03 | 1.5 %, min. 1 μm | 1 | 15 | 38.2 | 20 | 1.2 | | M10x1 |
| 4484517 | 844 DS-M | >40–60 | 0.6 | –0.02 / –0.03 | 1.5 %, min. 1 μm | 1 | 15 | 38.2 | 28 | 1.2 | | M10x1 |
| 4484518 | 844 DS-M | >60–80 | 0.6 | –0.025 / –0.035 | 1.5 %, min. 1 μm | 1 | 17.9 | 39 | 33 | 1.2 | | M10x1 |
| 4484519 | 844 DS-M | >80–100 | 0.6 | –0.025 / –0.035 | 1.5 %, min. 1 μm | 1 | 17.9 | 39 | 33 | 1.2 | | M10x1 |
| 4484520 | 844 DS-M | >100–110 | 0.6 | –0.025 / –0.035 | 1.5 %, min. 1 μm | 1 | 17.9 | 39 | 33 | 1.2 | | M10x1 |
| 4484521 | 844 DS-M | >110–120 | 0.6 | –0.025 / –0.035 | 1.5 %, min. 1 μm | 1 | 17.9 | 39 | 33 | 1.2 | | M10x1 |
| 4484522 | 844 DS-M | >120–130 | 0.6 | –0.025 / –0.035 | 1.5 %, min. 1 μm | 1 | 17.9 | 39 | 33 | 1.2 | | M10x1 |
| 4484523 | 844 DS-M | >130–140 | 0.6 | –0.035 / –0.045 | 1.5 %, min. 1 μm | 1 | 17.9 | 39 | 33 | 1.2 | | M10x1 |
| 4484524 | 844 DS-M | >140–150 | 0.6 | –0.035 / –0.045 | 1.5 %, min. 1 μm | 1 | 17.9 | 39 | 33 | 1.2 | | M10x1 |
| 4484525 | 844 DS-M | >150–160 | 0.6 | –0.035 / –0.045 | 1.5 %, min. 1 μm | 1 | 17.9 | 39 | 33 | 1.2 | | M10x1 |
| 4484526 | 844 DS-M | >160–170 | 0.6 | –0.035 / –0.045 | 1.5 %, min. 1 μm | 1 | 17.9 | 38.6 | 40 | 1.2 | | M10x1 |
| 4484527 | 844 DS-M | >170–180 | 0.6 | –0.035 / –0.045 | 1.5 %, min. 1 μm | 1 | 17.9 | 38.6 | 40 | 1.2 | | M10x1 |
| 4484528 | 844 DS-M | >180–190 | 0.6 | –0.035 / –0.045 | 1.5 %, min. 1 μm | 1 | 17.9 | 38.6 | 40 | 1.2 | | M10x1 |
| 4484529 | 844 DS-M | >190–200 | 0.6 | –0.035 / –0.045 | 1.5 %, min. 1 μm | 1 | 17.9 | 38.6 | 40 | 1.2 | | M10x1 |

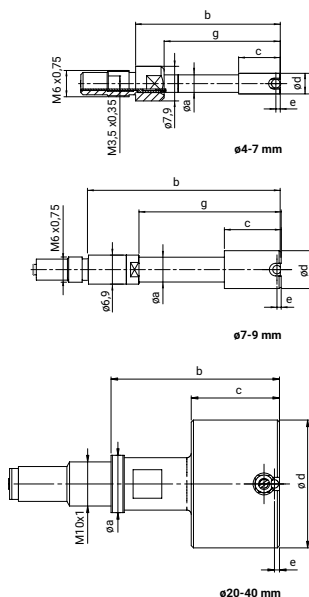

Marameter 844 D-HR

Indicating plug gage

FEATURES

- Measuring probe made of hardened, stainless guide cylinder and carbide tipped probes
- Carbide driving needle transfers radial measuring movement to the display unit
- Constant measuring force as a result of built-in spring, eliminating user influence
- Measuring head, measuring instrument holder, depth extensions, right angle attachments and depth stops form a comprehensive modular system

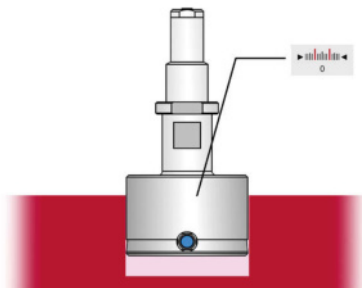

Application:

Standard version for very tight tolerance fields less than 10 µm

- Manufacturing tolerance of the guide cylinder reduced to 0.01 mm (±5 µm) to reduce the axial and radial measuring influences
- For the rapid testing of diameter, roundness and conicity of bores
- Ideal for testing batches with very tight tolerance fields less than 10 µm
- Rocking in the bore is not required to determine diameter
- Ideal for use in conjunction with digital display units and for subsequent processing of measured values

TECHNICAL DATA

| Order no. | Type | Measuring range | Measuring span | Manufacturing tolerance | Linearity deviation | Repeatability f_w | a | b | c | e | g | Connection thread |
|-----------|----------|-----------------|----------------|-------------------------|---------------------|---------------------|------|------|----|-----|----|-----------------------|
| | | mm | mm | mm / mm | | µm | mm | mm | mm | mm | mm | |
| 4484538 | 844 D-HR | 3–4 | 0.2 | −0.005 / −0.015 | 1 % , min. 1 µm | 1 | | 33.5 | 24 | 1.5 | 24 | M6 x 0.75 / M3.5x0.35 |
| 4484539 | 844 D-HR | >4–7 | 0.2 | −0.005 / −0.015 | 1 % , min. 1 µm | 1 | 4 | 33.5 | 10 | 1.5 | 27 | M6 x 0.75 / M3.5x0.35 |
| 4484540 | 844 D-HR | >7–9 | 0.2 | −0.005 / −0.015 | 1 % , min. 1 µm | 1 | 6.9 | 47 | 15 | 2.5 | 35 | M6 x 0.75 |
| 4484541 | 844 D-HR | >9–12 | 0.2 | −0.005 / −0.015 | 1 % , min. 1 µm | 1 | 7.9 | 47 | 15 | 2.5 | 47 | M6 x 0.75 |
| 4484542 | 844 D-HR | >12–13 | 0.2 | −0.005 / −0.015 | 1 % , min. 1 µm | 1 | 7.9 | 47 | 15 | 2.5 | 47 | M6 x 0.75 |
| 4484543 | 844 D-HR | >13–16 | 0.2 | −0.005 / −0.015 | 1 % , min. 1 µm | 1 | 11.9 | 47 | 15 | 2.5 | 47 | M6 x 0.75 |
| 4484544 | 844 D-HR | >16–20 | 0.2 | −0.005 / −0.015 | 1 % , min. 1 µm | 1 | 15 | 37.3 | 15 | 2.5 | | M10x1 |
| 4484545 | 844 D-HR | >20–30 | 0.2 | −0.01 / −0.02 | 1 % , min. 1 µm | 1 | 15 | 38.2 | 20 | 3.5 | | M10x1 |
| 4484546 | 844 D-HR | >30–40 | 0.2 | −0.01 / −0.02 | 1 % , min. 1 µm | 1 | 15 | 38.2 | 20 | 3.5 | | M10x1 |
| 4484547 | 844 D-HR | >40–60 | 0.2 | −0.01 / −0.02 | 1 % , min. 1 µm | 1 | 15 | 38.2 | 28 | 3.5 | | M10x1 |
| 4484548 | 844 D-HR | >60–80 | 0.2 | −0.015 / −0.025 | 1 % , min. 1 µm | 1 | 17.9 | 38.8 | 33 | 4 | | M10x1 |
| 4484549 | 844 D-HR | >80–100 | 0.2 | −0.015 / −0.025 | 1 % , min. 1 µm | 1 | 17.9 | 38.8 | 33 | 4 | | M10x1 |
| 4484550 | 844 D-HR | >100–110 | 0.2 | −0.015 / −0.025 | 1 % , min. 1 µm | 1 | 17.9 | 38.8 | 33 | 4 | | M10x1 |
| 4484551 | 844 D-HR | >110–120 | 0.2 | −0.015 / −0.025 | 1 % , min. 1 µm | 1 | 17.9 | 38.8 | 33 | 4 | | M10x1 |
| 4484552 | 844 D-HR | >120–130 | 0.2 | −0.015 / −0.025 | 1 % , min. 1 µm | 1 | 17.9 | 38.8 | 33 | 4 | | M10x1 |
| 4484553 | 844 D-HR | >130–140 | 0.2 | −0.025 / −0.035 | 1 % , min. 1 µm | 1 | 17.9 | 38.8 | 33 | 4 | | M10x1 |
| 4484554 | 844 D-HR | >140–150 | 0.2 | −0.025 / −0.035 | 1 % , min. 1 µm | 1 | 17.9 | 38.8 | 33 | 4 | | M10x1 |
| 4484555 | 844 D-HR | >150–160 | 0.2 | −0.025 / −0.035 | 1 % , min. 1 µm | 1 | 17.9 | 38.8 | 33 | 4 | | M10x1 |
| 4484556 | 844 D-HR | >160–170 | 0.2 | −0.025 / −0.035 | 1 % , min. 1 µm | 1 | 17.9 | 39 | 40 | 4 | | M10x1 |
| 4484557 | 844 D-HR | >170–180 | 0.2 | −0.025 / −0.035 | 1 % , min. 1 µm | 1 | 17.9 | 39 | 40 | 4 | | M10x1 |
| 4484558 | 844 D-HR | >180–190 | 0.2 | −0.025 / −0.035 | 1 % , min. 1 µm | 1 | 17.9 | 39 | 40 | 4 | | M10x1 |
| 4484559 | 844 D-HR | >190–200 | 0.2 | −0.025 / −0.035 | 1 % , min. 1 µm | 1 | 17.9 | 39 | 40 | 4 | | M10x1 |

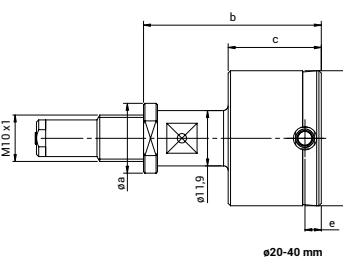
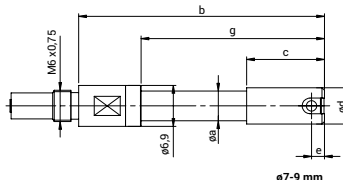
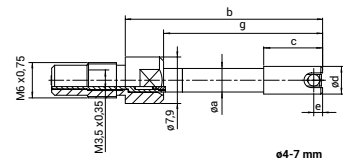

Marameter 844 DR-HR

Indicating plug gage

FEATURES

- Measuring probe made of hardened, stainless guide cylinder and carbide tipped probes
- Carbide driving needle transfers radial measuring movement to the display unit
- Constant measuring force as a result of built-in spring, eliminating user influence
- Measuring head, measuring instrument holder, depth extensions, right angle attachments and depth stops form a comprehensive modular system

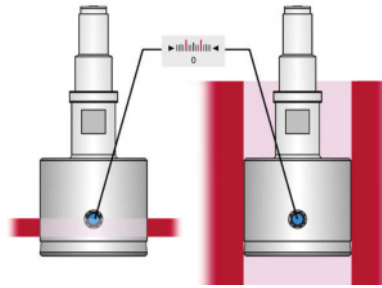

Application:

Model for through holes, for very tight tolerance fields less than 10 µm

- Manufacturing tolerance of the guide cylinder reduced to 0.01 mm ($\pm 5 \mu\text{m}$) to reduce the axial and radial measuring influences
- With extended guide cylinder for measuring through holes from the edge of the hole
- For the rapid testing of diameter, roundness and conicity of bores
- Ideal for testing batches with very tight tolerance fields less than 10 µm
- Rocking in the bore is not required to determine diameter
- Ideal for use in conjunction with digital display units and for subsequent processing of measured values

TECHNICAL DATA

| Order no. | Type | Measuring range | Measuring span | Manufacturing tolerance | Linearity | Repeatability f_w | a | b | c | e | g | Connection thread |
|-----------|-----------|-----------------|----------------|-------------------------|----------------|---------------------|------|------|------|----|------|-----------------------|
| | | mm | mm | mm / mm | | μm | mm | mm | mm | mm | mm | |
| 4484569 | 844 DR-HR | 4-7 | 0.2 | -0.005 / -0.015 | 1 %, min. 1 µm | 1 | 4 | 38 | 14.5 | 6 | 31.5 | M6 x 0.75 / M3.5x0.35 |
| 4484570 | 844 DR-HR | >7-9 | 0.2 | -0.005 / -0.015 | 1 %, min. 1 µm | 1 | 6.9 | 50.5 | 18.5 | 6 | 38.5 | M6 x 0.75 |
| 4484571 | 844 DR-HR | >9-12 | 0.2 | -0.005 / -0.015 | 1 %, min. 1 µm | 1 | 7.9 | 54.5 | 22.5 | 10 | 54.5 | M6 x 0.75 |
| 4484572 | 844 DR-HR | >12-13 | 0.2 | -0.005 / -0.015 | 1 %, min. 1 µm | 1 | 7.9 | 54.5 | 22.5 | 10 | 54.5 | M6 x 0.75 |
| 4484573 | 844 DR-HR | >13-16 | 0.2 | -0.005 / -0.015 | 1 %, min. 1 µm | 1 | 11.9 | 54.5 | 22.5 | 10 | 54.5 | M6 x 0.75 |
| 4484574 | 844 DR-HR | >16-20 | 0.2 | -0.005 / -0.015 | 1 %, min. 1 µm | 1 | 15 | 44.8 | 22.5 | 10 | | M10x1 |
| 4484575 | 844 DR-HR | >20-30 | 0.2 | -0.01 / -0.02 | 1 %, min. 1 µm | 1 | 15 | 44.7 | 27 | 10 | | M10x1 |
| 4484576 | 844 DR-HR | >30-40 | 0.2 | -0.01 / -0.02 | 1 %, min. 1 µm | 1 | 15 | 44.7 | 27 | 10 | | M10x1 |
| 4484577 | 844 DR-HR | >40-60 | 0.2 | -0.01 / -0.02 | 1 %, min. 1 µm | 1 | 15 | 44.7 | 28 | 10 | | M10x1 |
| 4484578 | 844 DR-HR | >60-80 | 0.2 | -0.015 / -0.025 | 1 %, min. 1 µm | 1 | 17.9 | 44.8 | 33 | 10 | | M10x1 |
| 4484579 | 844 DR-HR | >80-100 | 0.2 | -0.015 / -0.025 | 1 %, min. 1 µm | 1 | 17.9 | 44.8 | 33 | 10 | | M10x1 |
| 4484580 | 844 DR-HR | >100-110 | 0.2 | -0.015 / -0.025 | 1 %, min. 1 µm | 1 | 17.9 | 44.8 | 33 | 10 | | M10x1 |
| 4484581 | 844 DR-HR | >110-120 | 0.2 | -0.015 / -0.025 | 1 %, min. 1 µm | 1 | 17.9 | 44.8 | 33 | 10 | | M10x1 |
| 4484582 | 844 DR-HR | >120-130 | 0.2 | -0.015 / -0.025 | 1 %, min. 1 µm | 1 | 17.9 | 44.8 | 33 | 10 | | M10x1 |
| 4484583 | 844 DR-HR | >130-140 | 0.2 | -0.025 / -0.035 | 1 %, min. 1 µm | 1 | 17.9 | 44.8 | 33 | 10 | | M10x1 |
| 4484584 | 844 DR-HR | >140-150 | 0.2 | -0.025 / -0.035 | 1 %, min. 1 µm | 1 | 17.9 | 44.8 | 33 | 10 | | M10x1 |
| 4484585 | 844 DR-HR | >150-160 | 0.2 | -0.025 / -0.035 | 1 %, min. 1 µm | 1 | 17.9 | 44.8 | 33 | 10 | | M10x1 |
| 4484586 | 844 DR-HR | >160-170 | 0.2 | -0.025 / -0.035 | 1 %, min. 1 µm | 1 | 17.9 | 45 | 40 | 10 | | M10x1 |
| 4484587 | 844 DR-HR | >170-180 | 0.2 | -0.025 / -0.035 | 1 %, min. 1 µm | 1 | 17.9 | 45 | 40 | 10 | | M10x1 |
| 4484588 | 844 DR-HR | >180-190 | 0.2 | -0.025 / -0.035 | 1 %, min. 1 µm | 1 | 17.9 | 45 | 40 | 10 | | M10x1 |
| 4484589 | 844 DR-HR | >190-200 | 0.2 | -0.025 / -0.035 | 1 %, min. 1 µm | 1 | 17.9 | 45 | 40 | 10 | | M10x1 |

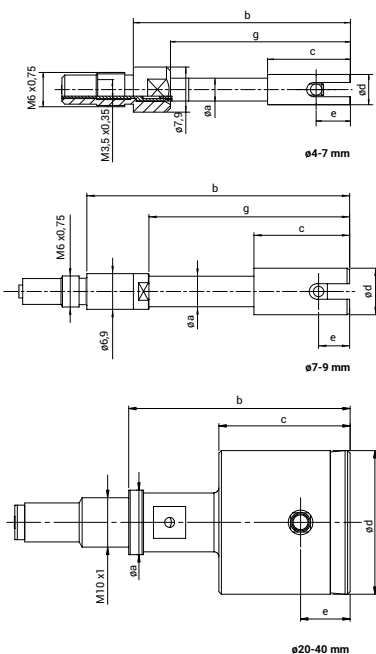

Marameter 844 DS-HR

Indicating plug gage

FEATURES

- Measuring probe made of hardened, stainless guide cylinder and carbide tipped probes
- Carbide driving needle transfers radial measuring movement to the display unit
- Constant measuring force as a result of built-in spring, eliminating user influence
- Measuring head, measuring instrument holder, depth extensions, right angle attachments and depth stops form a comprehensive modular system

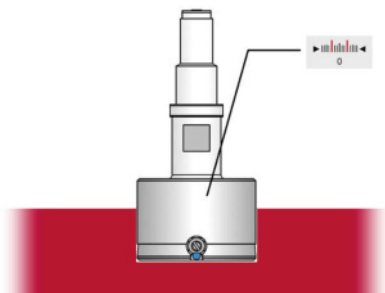

Application: Model for blind holes, for very tight tolerance fields less than 10 µm

- Manufacturing tolerance of the guide cylinder reduced to 0.01 mm ($\pm 5 \mu\text{m}$) to reduce the axial and radial measuring influences
- For measurements close to the base of the hole
- For the rapid testing of diameter, roundness and conicity of bores
- Ideal for testing batches with very tight tolerance fields less than 10 µm
- Rocking in the bore is not required to determine diameter
- Ideal for use in conjunction with digital display units and for subsequent processing of measured values

TECHNICAL DATA

| Order no. | Type | Measuring range | Measuring span | Manufacturing tolerance | Linearity deviation | Repeatability f_w | a | b | c | e | g | Connection thread |
|-----------|-----------|-----------------|----------------|-------------------------|---------------------|---------------------|------|------|------|-----|------|-----------------------|
| 4484598 | 844 DS-HR | 3–4 | 0.2 | -0.005 / -0.015 | 1.5 %, min. 1 µm | 1 | | 33 | 23.5 | 1 | 23.5 | M6 x 0.75 / M3.5x0.35 |
| 4484599 | 844 DS-HR | >4–7 | 0.2 | -0.005 / -0.015 | 1.5 %, min. 1 µm | 1 | 4 | 33 | 9.5 | 1 | 26.5 | M6 x 0.75 / M3.5x0.35 |
| 4484600 | 844 DS-HR | >7–9 | 0.2 | -0.005 / -0.015 | 1.5 %, min. 1 µm | 1 | 6.9 | 45.5 | 13.5 | 1 | 33.5 | M6 x 0.75 |
| 4484601 | 844 DS-HR | >9–12 | 0.2 | -0.005 / -0.015 | 1.5 %, min. 1 µm | 1 | 7.9 | 45.5 | 13.5 | 1 | 45.5 | M6 x 0.75 |
| 4484602 | 844 DS-HR | >12–13 | 0.2 | -0.005 / -0.015 | 1.5 %, min. 1 µm | 1 | 7.9 | 45.5 | 13.5 | 1 | 45.5 | M6 x 0.75 |
| 4484603 | 844 DS-HR | >13–16 | 0.2 | -0.005 / -0.015 | 1.5 %, min. 1 µm | 1 | 11.9 | 45.5 | 13.5 | 1 | 45.5 | M6 x 0.75 |
| 4484604 | 844 DS-HR | >16–20 | 0.2 | -0.005 / -0.015 | 1.5 %, min. 1 µm | 1 | 15 | 35.8 | 13.5 | 1 | | M10x1 |
| 4484605 | 844 DS-HR | >20–30 | 0.2 | -0.01 / -0.02 | 1.5 %, min. 1 µm | 1 | 15 | 38.2 | 20 | 1.2 | | M10x1 |
| 4484606 | 844 DS-HR | >30–40 | 0.2 | -0.01 / -0.02 | 1.5 %, min. 1 µm | 1 | 15 | 38.2 | 20 | 1.2 | | M10x1 |
| 4484607 | 844 DS-HR | >40–60 | 0.2 | -0.01 / -0.02 | 1.5 %, min. 1 µm | 1 | 15 | 38.2 | 28 | 1.2 | | M10x1 |
| 4484608 | 844 DS-HR | >60–80 | 0.2 | -0.015 / -0.025 | 1.5 %, min. 1 µm | 1 | 17.9 | 39 | 33 | 1.2 | | M10x1 |
| 4484609 | 844 DS-HR | >80–100 | 0.2 | -0.015 / -0.025 | 1.5 %, min. 1 µm | 1 | 17.9 | 39 | 33 | 1.2 | | M10x1 |
| 4484610 | 844 DS-HR | >100–110 | 0.2 | -0.015 / -0.025 | 1.5 %, min. 1 µm | 1 | 17.9 | 39 | 33 | 1.2 | | M10x1 |
| 4484611 | 844 DS-HR | >110–120 | 0.2 | -0.015 / -0.025 | 1.5 %, min. 1 µm | 1 | 17.9 | 39 | 33 | 1.2 | | M10x1 |
| 4484612 | 844 DS-HR | >120–130 | 0.2 | -0.015 / -0.025 | 1.5 %, min. 1 µm | 1 | 17.9 | 39 | 33 | 1.2 | | M10x1 |
| 4484613 | 844 DS-HR | >130–140 | 0.2 | -0.025 / -0.035 | 1.5 %, min. 1 µm | 1 | 17.9 | 39 | 33 | 1.2 | | M10x1 |
| 4484614 | 844 DS-HR | >140–150 | 0.2 | -0.025 / -0.035 | 1.5 %, min. 1 µm | 1 | 17.9 | 39 | 33 | 1.2 | | M10x1 |
| 4484615 | 844 DS-HR | >150–160 | 0.2 | -0.025 / -0.035 | 1.5 %, min. 1 µm | 1 | 17.9 | 39 | 33 | 1.2 | | M10x1 |
| 4484616 | 844 DS-HR | >160–170 | 0.2 | -0.025 / -0.035 | 1.5 %, min. 1 µm | 1 | 17.9 | 38.6 | 40 | 1.2 | | M10x1 |
| 4484617 | 844 DS-HR | >170–180 | 0.2 | -0.025 / -0.035 | 1.5 %, min. 1 µm | 1 | 17.9 | 38.6 | 40 | 1.2 | | M10x1 |
| 4484618 | 844 DS-HR | >180–190 | 0.2 | -0.025 / -0.035 | 1.5 %, min. 1 µm | 1 | 17.9 | 38.6 | 40 | 1.2 | | M10x1 |
| 4484619 | 844 DS-HR | >190–200 | 0.2 | -0.025 / -0.035 | 1.5 %, min. 1 µm | 1 | 17.9 | 38.6 | 40 | 1.2 | | M10x1 |

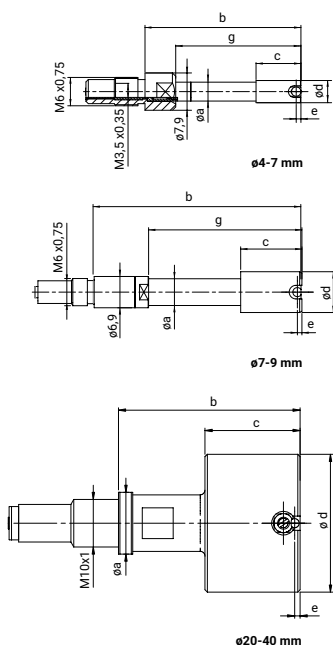

Marameter 844 DS-F

Indicating plug gage

FEATURES

- Measuring probe made of hardened, stainless guide cylinder and carbide tipped probes
- Carbide driving needle transfers radial measuring movement to the display unit
- Constant measuring force as a result of built-in spring, eliminating user influence
- Measuring head, measuring instrument holder, depth extensions, right angle attachments and depth stops form a comprehensive modular system

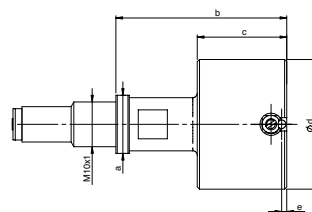
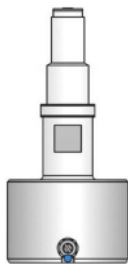

020-40mm

Application: Model for blind holes, with front chamfer

- For measuring very short bores
- For measurements close to the base of the hole
- For rapid testing of diameter, roundness and conicity of bores
- Especially suitable for testing batches with tight tolerance zones
- Rocking in the bore is not required to determine diameter
- Ideal for use in conjunction with digital display units and for subsequent processing of measured values

TECHNICAL DATA

| Order no. | Type | Measuring range | Measuring span | Manufacturing tolerance | Linearity deviation | Repeatability f_w | a | b | c | e | g | Connection thread |
|-----------|----------|-----------------|----------------|-------------------------|-----------------------------|---------------------|------|------|------|-----|------|-----------------------|
| | | mm | mm | mm / mm | | μm | mm | mm | mm | mm | mm | |
| 4484627 | 844 DS-F | 2–2,999 | 0.15 | -0.015 / -0.025 | 1.5 %, min. 1 μm | 1 | | 20.7 | 14,2 | 0.7 | 14,2 | M6 x 0.75 / M3.5x0.35 |
| 4484628 | 844 DS-F | 3–4 | 0.2 | -0.015 / -0.025 | 1.5 %, min. 1 μm | 1 | | 33 | 23.5 | 1 | 23.5 | M6 x 0.75 / M3.5x0.35 |
| 4484629 | 844 DS-F | >4–7 | 0.2 | -0.015 / -0.025 | 1.5 %, min. 1 μm | 1 | 4 | 33 | 9.5 | 1 | 26.5 | M6 x 0.75 / M3.5x0.35 |
| 4484630 | 844 DS-F | >7–9 | 0.2 | -0.015 / -0.025 | 1.5 %, min. 1 μm | 1 | 6.9 | 45.5 | 13.5 | 1 | 33.5 | M6 x 0.75 |
| 4484631 | 844 DS-F | >9–12 | 0.2 | -0.015 / -0.025 | 1.5 %, min. 1 μm | 1 | 7.9 | 45.5 | 13.5 | 1 | 45.5 | M6 x 0.75 |
| 4484632 | 844 DS-F | >12–13 | 0.2 | -0.015 / -0.025 | 1.5 %, min. 1 μm | 1 | 7.9 | 45.5 | 13.5 | 1 | 45.5 | M6 x 0.75 |
| 4484633 | 844 DS-F | >13–16 | 0.2 | -0.015 / -0.025 | 1.5 %, min. 1 μm | 1 | 11.9 | 45.5 | 13.5 | 1 | 45.5 | M6 x 0.75 |
| 4484634 | 844 DS-F | >16–20 | 0.2 | -0.015 / -0.025 | 1.5 %, min. 1 μm | 1 | 15 | 35.8 | 13.5 | 1 | | M10x1 |
| 4484635 | 844 DS-F | >20–30 | 0.2 | -0.02 / -0.03 | 1.5 %, min. 1 μm | 1 | 15 | 38.2 | 20 | 1.2 | | M10x1 |
| 4484636 | 844 DS-F | >30–40 | 0.2 | -0.02 / -0.03 | 1.5 %, min. 1 μm | 1 | 15 | 38.2 | 20 | 1.2 | | M10x1 |
| 4484637 | 844 DS-F | >40–60 | 0.2 | -0.02 / -0.03 | 1.5 %, min. 1 μm | 1 | 15 | 38.2 | 28 | 1.2 | | M10x1 |
| 4484638 | 844 DS-F | >60–80 | 0.2 | -0.025 / -0.035 | 1.5 %, min. 1 μm | 1 | 17.9 | 39 | 33 | 1.2 | | M10x1 |
| 4484639 | 844 DS-F | >80–100 | 0.2 | -0.025 / -0.035 | 1.5 %, min. 1 μm | 1 | 17.9 | 39 | 33 | 1.2 | | M10x1 |
| 4484640 | 844 DS-F | >100–110 | 0.2 | -0.025 / -0.035 | 1.5 %, min. 1 μm | 1 | 17.9 | 39 | 33 | 1.2 | | M10x1 |
| 4484641 | 844 DS-F | >110–120 | 0.2 | -0.025 / -0.035 | 1.5 %, min. 1 μm | 1 | 17.9 | 39 | 33 | 1.2 | | M10x1 |
| 4484642 | 844 DS-F | >120–130 | 0.2 | -0.025 / -0.035 | 1.5 %, min. 1 μm | 1 | 17.9 | 39 | 33 | 1.2 | | M10x1 |
| 4484643 | 844 DS-F | >130–140 | 0.2 | -0.035 / -0.045 | 1.5 %, min. 1 μm | 1 | 17.9 | 39 | 33 | 1.2 | | M10x1 |
| 4484644 | 844 DS-F | >140–150 | 0.2 | -0.035 / -0.045 | 1.5 %, min. 1 μm | 1 | 17.9 | 39 | 33 | 1.2 | | M10x1 |
| 4484645 | 844 DS-F | >150–160 | 0.2 | -0.035 / -0.045 | 1.5 %, min. 1 μm | 1 | 17.9 | 39 | 33 | 1.2 | | M10x1 |
| 4484646 | 844 DS-F | >160–170 | 0.2 | -0.035 / -0.045 | 1.5 %, min. 1 μm | 1 | 17.9 | 38.6 | 40 | 1.2 | | M10x1 |
| 4484647 | 844 DS-F | >170–180 | 0.2 | -0.035 / -0.045 | 1.5 %, min. 1 μm | 1 | 17.9 | 38.6 | 40 | 1.2 | | M10x1 |
| 4484648 | 844 DS-F | >180–190 | 0.2 | -0.035 / -0.045 | 1.5 %, min. 1 μm | 1 | 17.9 | 38.6 | 40 | 1.2 | | M10x1 |
| 4484649 | 844 DS-F | >190–200 | 0.2 | -0.035 / -0.045 | 1.5 %, min. 1 μm | 1 | 17.9 | 38.6 | 40 | 1.2 | | M10x1 |

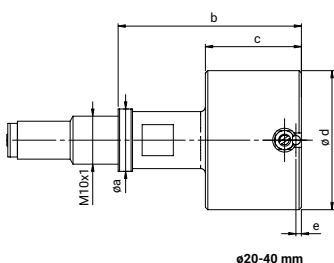
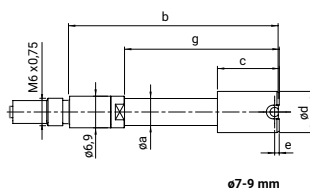
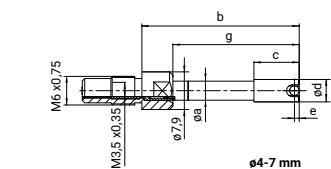

Marameter 844 D-3

Indicating plug gage

FEATURES

- Measuring head has hard, stainless cylinder guide and carbide tipped anvils (spaced at $3 \times 120^\circ$)
- The carbide expanding pin transfers radial movement to indicating instrument
- Constant measuring force as a result of built-in spring, eliminating user influence
- Extensive modular system is composed of measuring head, holder, depth extension, right angle attachments and depth stops

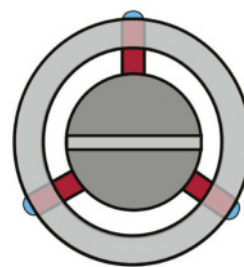
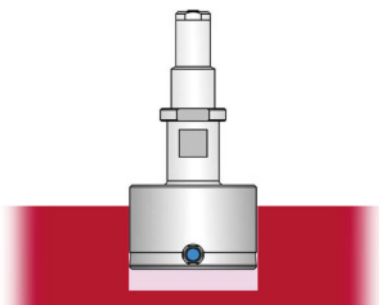

Application:

Standard model, with 3-point contact (gaging contacts spaced $3 \times 120^\circ$)

- For fast measurement of interrupted diameters and detection of form deviations in a polygon
- Especially suitable for testing batches with tight tolerance zones
- Rocking in the bore is not required to determine diameter
- Ideal for use in conjunction with digital display units and for subsequent processing of measured values

TECHNICAL DATA

| Order no. | Type | Measuring range | Measuring span | Manufacturing tolerance | Linearity deviation | Repeatability f_w | a | b | c | e | Connection thread |
|-----------|---------|-----------------|----------------|-------------------------|---------------------------|---------------------|------|------|----|-----|-------------------|
| | | mm | mm | mm / mm | | μm | mm | mm | mm | mm | |
| 4484659 | 844 D-3 | 4-7 | 0.2 | -0.015 / -0.025 | 2 %, min. 1 μm | 1 | 4 | 33.5 | 10 | 1.5 | M6 x 0.75 |
| 4484660 | 844 D-3 | >7-9 | 0.2 | -0.015 / -0.025 | 2 %, min. 1 μm | 1 | 6.9 | 47 | 15 | 2.5 | M6 x 0.75 |
| 4484661 | 844 D-3 | >9-12 | 0.2 | -0.015 / -0.025 | 2 %, min. 1 μm | 1 | 7.9 | 47 | 15 | 2.5 | M6 x 0.75 |
| 4484662 | 844 D-3 | >12-13 | 0.2 | -0.015 / -0.025 | 2 %, min. 1 μm | 1 | 7.9 | 47 | 15 | 2.5 | M6 x 0.75 |
| 4484663 | 844 D-3 | >13-16 | 0.2 | -0.015 / -0.025 | 2 %, min. 1 μm | 1 | 11.9 | 47 | 15 | 2.5 | M6 x 0.75 |
| 4484664 | 844 D-3 | >16-20 | 0.2 | -0.015 / -0.025 | 2 %, min. 1 μm | 1 | 15 | 37 | 15 | 2.5 | M10x1 |
| 4484665 | 844 D-3 | >20-30 | 0.2 | -0.02 / -0.03 | 2 %, min. 1 μm | 1 | 15 | 38.2 | 20 | 3.5 | M10x1 |
| 4484666 | 844 D-3 | >30-40 | 0.2 | -0.02 / -0.03 | 2 %, min. 1 μm | 1 | 15 | 38.2 | 20 | 3.5 | M10x1 |
| 4484667 | 844 D-3 | >40-60 | 0.2 | -0.02 / -0.03 | 2 %, min. 1 μm | 1 | 15 | 38.2 | 28 | 3.5 | M10x1 |
| 4484668 | 844 D-3 | >60-80 | 0.2 | -0.025 / -0.035 | 2 %, min. 1 μm | 1 | 17.9 | 38.8 | 33 | 4 | M10x1 |
| 4484669 | 844 D-3 | >80-100 | 0.2 | -0.025 / -0.035 | 2 %, min. 1 μm | 1 | 17.9 | 38.8 | 33 | 4 | M10x1 |

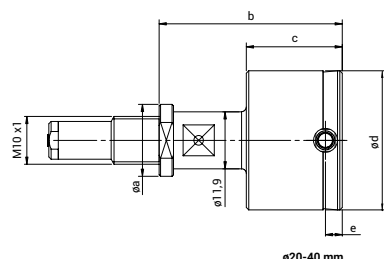
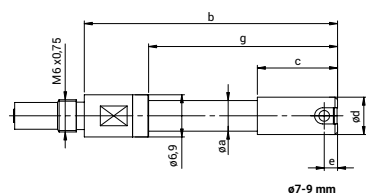
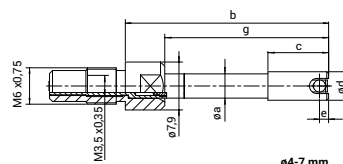

Marameter 844 DR-3

Indicating plug gage

FEATURES

- Measuring head has hard, stainless cylinder guide and carbide tipped anvils (spaced at $3 \times 120^\circ$)
- The carbide expanding pin transfers radial movement to indicating instrument
- Constant measuring force as a result of built-in spring, eliminating user influence
- Extensive modular system is composed of measuring head, holder, depth extension, right angle attachments and depth stops

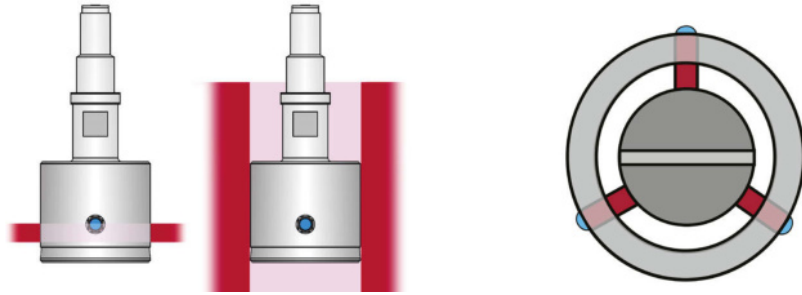

Application:

Model for through holes, with 3-point contact (gaging contacts spaced $3 \times 120^\circ$)

- For fast measurement of interrupted diameters and detection of form deviations in a polygon
- Especially suitable for testing batches with tight tolerance zones
- Rocking in the bore is not required to determine diameter
- Ideal for use in conjunction with digital display units and for subsequent processing of measured values

TECHNICAL DATA

| Order no. | Type | Measuring range | Measuring span | Manufacturing tolerance | Linearity deviation | Repeatability f_w | a | b | c | e | Connection thread |
|-----------|----------|-----------------|----------------|-------------------------|---------------------------|---------------------|------|------|------|----|-----------------------|
| | | mm | mm | mm / mm | | μm | mm | mm | mm | mm | |
| 4484689 | 844 DR-3 | 4-7 | 0.2 | -0.015 / -0.025 | 2 %, min. 1 μm | 1 | 4 | 38 | 14.5 | 6 | M6 x 0.75 / M3.5x0.35 |
| 4484690 | 844 DR-3 | >7-9 | 0.2 | -0.015 / -0.025 | 2 %, min. 1 μm | 1 | 6.9 | 50.5 | 18.5 | 6 | M6 x 0.75 |
| 4484691 | 844 DR-3 | >9-12 | 0.2 | -0.015 / -0.025 | 2 %, min. 1 μm | 1 | 7.9 | 54.5 | 22.5 | 10 | M6 x 0.75 |
| 4484692 | 844 DR-3 | >12-13 | 0.2 | -0.015 / -0.025 | 2 %, min. 1 μm | 1 | 7.9 | 54.5 | 22.5 | 10 | M6 x 0.75 |
| 4484693 | 844 DR-3 | >13-16 | 0.2 | -0.015 / -0.025 | 2 %, min. 1 μm | 1 | 11.9 | 54.5 | 22.5 | 10 | M6 x 0.75 |
| 4484694 | 844 DR-3 | >16-20 | 0.2 | -0.015 / -0.025 | 2 %, min. 1 μm | 1 | 15 | 44.6 | 22.5 | 10 | M10x1 |
| 4484695 | 844 DR-3 | >20-30 | 0.2 | -0.02 / -0.03 | 2 %, min. 1 μm | 1 | 15 | 44.7 | 27 | 10 | M10x1 |
| 4484696 | 844 DR-3 | >30-40 | 0.2 | -0.02 / -0.03 | 2 %, min. 1 μm | 1 | 15 | 44.7 | 27 | 10 | M10x1 |
| 4484697 | 844 DR-3 | >40-60 | 0.2 | -0.02 / -0.03 | 2 %, min. 1 μm | 1 | 15 | 44.7 | 28 | 10 | M10x1 |
| 4484698 | 844 DR-3 | >60-80 | 0.2 | -0.025 / -0.035 | 2 %, min. 1 μm | 1 | 17.9 | 44.8 | 33 | 10 | M10x1 |
| 4484699 | 844 DR-3 | >80-100 | 0.2 | -0.025 / -0.035 | 2 %, min. 1 μm | 1 | 17.9 | 44.8 | 33 | 10 | M10x1 |

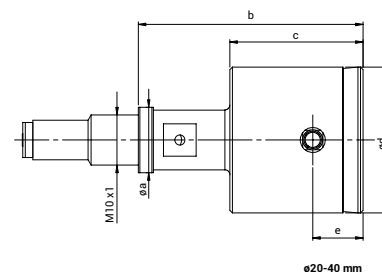
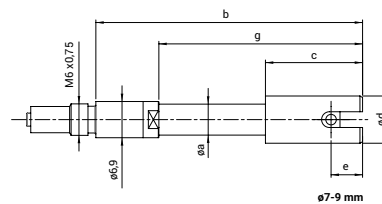
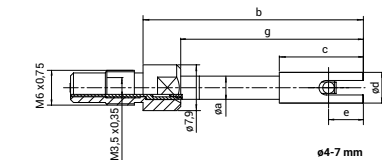

Marameter 844 Dgk / 844 Dga / 844 Dg / 844 Dg-XL / 844 Dgk-Z / 844 Dg-Z

Holder for plug gage

FEATURES

- The measuring instrument holder comprises a handle with a transfer rod, other properties:
 - Holder for upper cylinder shaft \varnothing 8 mm, for display unit e.g. dial comparator or digital dial indicator
 - Lower connecting thread to hold a bore plug gage 844 D / 844 DR / 844 DS



Applications:

- Type 844 Dga:** Special model with clearance button, useful e.g. for sensitive workpieces for inserting a bore plug gage into blind hole model 844 DS more easily. Recommended for small and sensitive holes.
- Type 844 Dg-XL:** Heavy duty and stable design for large bore plug gages (possible from \varnothing 60 mm), especially when using measuring depth extensions 844 Dv (\varnothing 18 mm) for large measuring depths.

TECHNICAL DATA

| Order no. | Type | Connection thread | Lifting lever |
|-----------|-----------|-------------------|---------------|
| 4484750 | 844 Dgk | M10 x 1 | |
| 4484751 | 844 Dga | M10 x 1 | • |
| 4484752 | 844 Dg | M6 x 0.75 | |
| 4484753 | 844 Dg | M10 x 1 | |
| 4484754 | 844 Dg | M6 x 0.75 | |
| 4484755 | 844 Dg | M10 x 1 | |
| 4484756 | 844 Dg-XL | M10 x 1 | |
| 4484757 | 844 Dg-XL | M10 x 1 | |
| 4484758 | 844 Dgk-Z | M10 x 1 | |
| 4484759 | 844 Dg-Z | M10 x 1 | |

| Order no. | Connection thread | Dimension L | d1 | d2 | l |
|-----------|-------------------|-------------|------|----|-----|
| | | mm | mm | mm | mm |
| 4484750 | M10 x 1 | 59 | 11.9 | 18 | 11 |
| 4484751 | M10 x 1 | 83 | 11.9 | 18 | 36 |
| 4484752 | M6 x 0.75 | 109 | 11.9 | 18 | 30 |
| 4484753 | M10 x 1 | 109 | 11.9 | 18 | 40 |
| 4484754 | M6 x 0.75 | 239 | 11.9 | 18 | 137 |
| 4484755 | M10 x 1 | 249 | 11.9 | 18 | 147 |
| 4484756 | M10 x 1 | 154 | 17.9 | 26 | 38 |
| 4484757 | M10 x 1 | 244 | 17.9 | 26 | 128 |
| 4484758 | M10 x 1 | 59 | 11.9 | 18 | 11 |
| 4484759 | M10 x 1 | 109 | 11.9 | 18 | 30 |

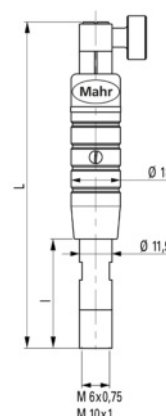

ACCESSORIES

| Order no. | Description | Type |
|-----------|---|-----------|
| 4334000 | Millimess 1 μ m, \pm 50 μ m | 1003 |
| 4334102 | Millimess 0.5 μ m, \pm 25 μ m | 1002 |
| 4337620 | Digital indicator, 0.0005 mm, 12.5 mm | 1086 R |
| 4337624 | Digital indicator, 0.0005 mm, 12.5 mm | 1086 Ri |
| 4337697 | Digital indicator, 0.0001 mm, 12.5 mm | 1086 R-HR |



1003



1086 R-HR;1086 R;1086 ZR

Marameter 844 Dge

Plug gage holder for inductive probe

FEATURES

- The plug gage holders for inductive probes consist of a handle with cable protection on top
- Fixture (in the handle) for an inductive probe \varnothing 8 mm e.g. P2004-M for connection to an amplifier e.g. C1200-M
- Integrated fine adjustment for best probe setting
- Connection thread at the bottom to mount a bore gage 844 D / 844 DR / 844 DS



Applications:

- Special plug gage holders for precise measurements with inductive probes
- Mounting element in the holder for inductive probes with cylindrical shaft \varnothing 8 mm
- Cable socket with bend protection
- Fine adjustment attachment for the inductive probe
- Connection thread at the bottom for mounting a plug gage 844 D / 844 DR / 844 DS

TECHNICAL DATA

| Order no. | Type | Dimension L | l | Connection thread |
|-----------|---------|-------------|----|-------------------|
| 4484760 | 844 Dge | mm | mm | M6 x 0.75 |
| 4484761 | 844 Dge | 146 | 26 | M6 x 0.75 |
| | | 156 | 36 | M10x1 |

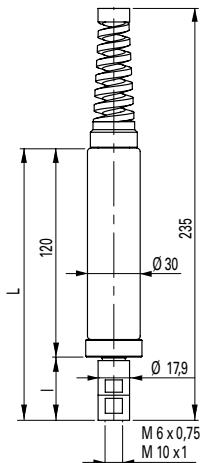

ACCESSORIES

| Order no. | Description | Type |
|-----------|-----------------------------|----------|
| 5312012 | Compact amplifier | C 1200 M |
| 5323010 | Inductive probe, \pm 2 mm | P2004 M |



P2004 M



C 1200 M

Marameter 844 Dv

Extension for measuring depth

FEATURES

- The 844 Dv depth extension is screwed in between holder 844 Dg and plug gage 844 D / 844 DR / 844 DS (if necessary right angle attachment 844 Dw)



Applications:

- For bore measurement at larger depths
- Practical additional function as clamping shank for depth measuring stops 844 Dt

TECHNICAL DATA

| Order no. | Type | Dimension L | d1 | d2 | Connection thread |
|-----------|--------|-------------|------|-----|-----------------------|
| | | mm | mm | mm | |
| 4484770 | 844 Dv | 49 | 4 | 7.9 | M6 x 0.75 / M3.5x0.35 |
| 4484771 | 844 Dv | 99 | 4 | 7.9 | M6 x 0.75 / M3.5x0.35 |
| 4484772 | 844 Dv | 149 | 4 | 7.9 | M6 x 0.75 / M3.5x0.35 |
| 4484773 | 844 Dv | 249 | 4 | 7.9 | M6 x 0.75 / M3.5x0.35 |
| 4484774 | 844 Dv | 50 | 6.5 | 7.9 | M6 x 0.75 |
| 4484775 | 844 Dv | 100 | 6.5 | 7.9 | M6 x 0.75 |
| 4484776 | 844 Dv | 150 | 6.5 | 7.9 | M6 x 0.75 |
| 4484777 | 844 Dv | 250 | 6.5 | 7.9 | M6 x 0.75 |
| 4484778 | 844 Dv | 500 | 6.5 | 7.9 | M6 x 0.75 |
| 4484779 | 844 Dv | 48 | 11.9 | 15 | M10x1 |
| 4484780 | 844 Dv | 98 | 11.9 | 15 | M10x1 |
| 4484781 | 844 Dv | 248 | 11.9 | 15 | M10x1 |
| 4484782 | 844 Dv | 498 | 11.9 | 15 | M10x1 |
| 4484783 | 844 Dv | 750 | 11.9 | 15 | M10x1 |
| 4484784 | 844 Dv | 1000 | 11.9 | 15 | M10x1 |
| 4484785 | 844 Dv | 100 | 17.9 | | M10x1 |
| 4484786 | 844 Dv | 250 | 17.9 | | M10x1 |
| 4484787 | 844 Dv | 500 | 17.9 | | M10x1 |
| 4484788 | 844 Dv | 750 | 17.9 | | M10x1 |
| 4484789 | 844 Dv | 1000 | 17.9 | | M10x1 |

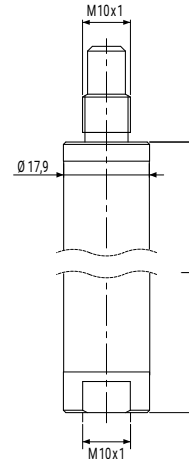
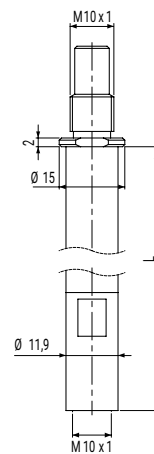
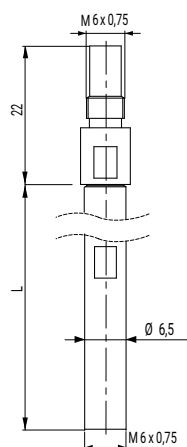
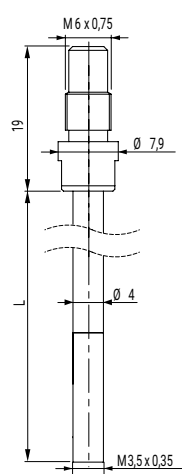

Marameter 844 Dw

Right angle attachment

FEATURES

- The 844 Dw right angle attachment is screwed in between holder 844 Dg and plug gage 844 D / 844 DR / 844 DS (if necessary extensions 844 Dv)

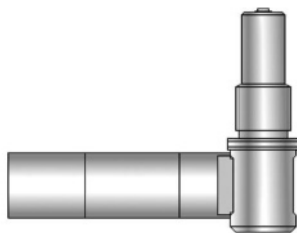

Applications:

- For space-saving and side entering measurement of bores. Typical measuring problem situations:
- Narrow conditions in turning and grinding machines
- Side outgoing bores or bearing points in housings

TECHNICAL DATA

| Order no. | Type | Dimension L | d | Connection thread |
|-----------|--------|-------------|------|-------------------|
| | | mm | mm | |
| 4473409 | 844 Kw | 29 | 7.9 | M6 x 0.75 |
| 4484790 | 844 Dw | 53 | 11.9 | M10x1 |
| 4484791 | 844 Dw | 56 | 17.9 | M10x1 |

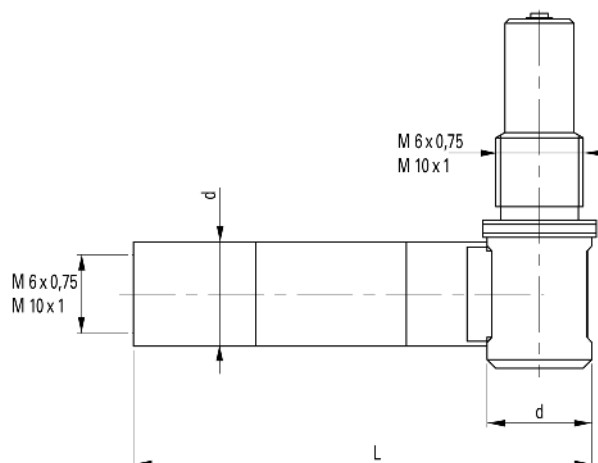

Marameter 844 Dt-R

Depth-stop ring

FEATURES

- For clamping direct on guide cylinder of plug gage 844 D / 844 DR / 844 DS

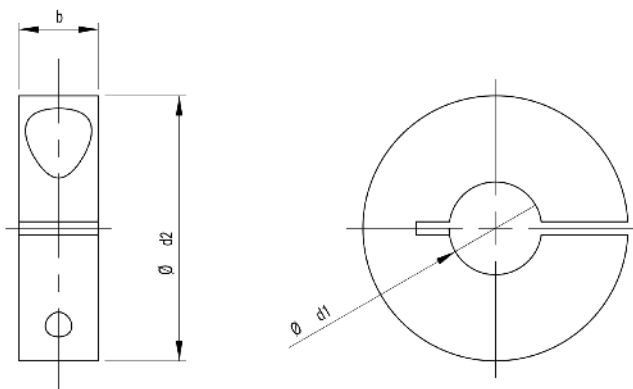

Application:

- For measuring at a defined and repeatable measuring depth and to eliminate a tilt error

TECHNICAL DATA

| Order no. | Type | Application range |
|-----------|----------|------------------------------|
| | | mm |
| 4484800 | 844 Dt-R | For plug gages Ø 3 –40 mm |
| 4484801 | 844 Dt-R | For plug gages Ø >40 –60 mm |
| 4484802 | 844 Dt-R | For plug gages Ø >60 –90 mm |
| 4484803 | 844 Dt-R | For plug gages Ø >90 –105 mm |

| Order no. | Dimension d1 Comment | d1 | d2 | b |
|-----------|--|------------|-----------|-------|
| 4484800 | Adjusted according to the guide cylinder diameter of the plug gage | 3–5 mm | 12 mm | 6 mm |
| | | >5–9 mm | 25 mm | 10 mm |
| | | >9–14 mm | 32 mm | 10 mm |
| | | >14–18 mm | 40 mm | 12 mm |
| | | >18–24 mm | 45 mm | 12 mm |
| | | >24–28 mm | 50 mm | 12 mm |
| | | >28–35 mm | 56 mm | 12 mm |
| | >35–40 mm | 63 mm | 12 mm | |
| 4484801 | Adjusted according to the guide cylinder diameter of the plug gage | >40–45 mm | 70 mm | 14 mm |
| | | >45–55 mm | 80 mm | 14 mm |
| | | >55–60 mm | 90 mm | 16 mm |
| 4484802 | Adjusted according to the guide cylinder diameter of the plug gage | >60–70 mm | 100 mm | 16 mm |
| | | >70–90 mm | 125 mm | 20 mm |
| 4484803 | Adjusted according to the guide cylinder diameter of the plug gage | >90–105 mm | 90–105 mm | 25 mm |

Marameter 844 Dt-S

Depth-stop disc

FEATURES

- Full round design
- For clamping on the shaft of the plug gage holder 844 Dg or measuring depth extension 844 Dv

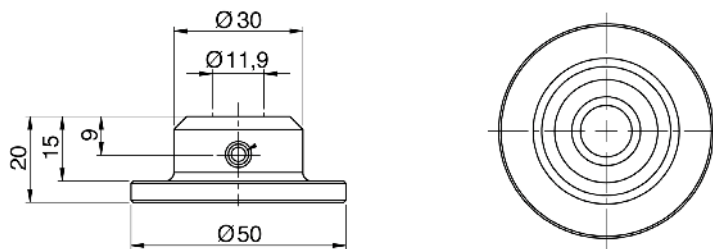

Application:

- For measuring at a defined and repeatable measuring depth and to eliminate a tilt error

TECHNICAL DATA

| Order no. | Type | Application range | Mount diameter | Stop surfaces Ø A |
|-----------|----------|--------------------------------------|----------------|--|
| 4484820 | 844 Dt-S | mm For plug gages Ø 16 – 40 mm | mm Ø 11.9 | mm Full round design, diameter 50 mm |

Marameter 844 Dt-B

Depth-stop bridge

FEATURES

- For clamping on the shaft of the plug gage holder 844 Dg or measuring depth extension 844 Dv

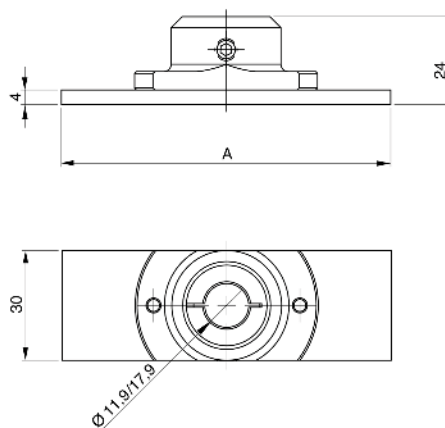

Application:

- For measuring at a defined and repeatable measuring depth and to eliminate a tilt error

TECHNICAL DATA

| Order no. | Type | Application range | Mount diameter |
|-----------|----------|---|---|
| | | mm | mm |
| 4484821 | 844 Dt-B | For plug gages \varnothing 16 –60 mm | \varnothing 11.9 mm or \varnothing 17.9 mm as specified, according to clamping shank \varnothing of holder 844 Dg/Dg-XL or measuring depth extension 844 Dv |
| 4484822 | 844 Dt-B | For plug gages \varnothing >60 –80 mm | \varnothing 11.9 mm or \varnothing 17.9 mm as specified, according to clamping shank \varnothing of holder 844 Dg/Dg-XL or measuring depth extension 844 Dv |
| 4484823 | 844 Dt-B | For plug gages \varnothing >80 –100 mm | \varnothing 11.9 mm or \varnothing 17.9 mm as specified, according to clamping shank \varnothing of holder 844 Dg/Dg-XL or measuring depth extension 844 Dv |
| 4484824 | 844 Dt-B | For plug gages \varnothing >100 –160 mm | \varnothing 11.9 mm or \varnothing 17.9 mm as specified, according to clamping shank \varnothing of holder 844 Dg/Dg-XL or measuring depth extension 844 Dv |

| Order no. | Stop surfaces \varnothing A |
|-----------|---------------------------------|
| | mm |
| 4484821 | Bore plug gage diameter + 10 mm |
| 4484822 | Bore plug gage diameter + 10 mm |
| 4484823 | Bore plug gage diameter + 10 mm |
| 4484824 | Bore plug gage diameter + 10 mm |

Marameter 844 Dt-3

Depth stop with 3-point contacting

FEATURES

- For clamping on the shaft of the plug gage holder 844 Dg or measuring depth extension 844 Dv

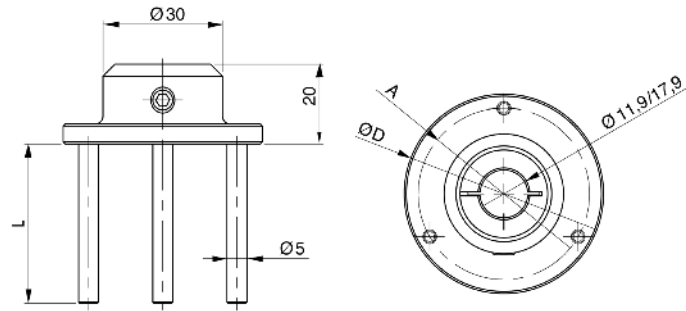

Application:

- For measuring at a defined and repeatable measuring depth and to eliminate a tilt error

TECHNICAL DATA

| Order no. | Type | Application range | Mount diameter |
|-----------|----------|---|--|
| | | mm | mm |
| 4484810 | 844 Dt-3 | For plug gages \varnothing 20 –60 mm | \varnothing 11.9 mm or \varnothing 17.9 mm As specified, depending on clamping shank \varnothing of holder 844 Dg/Dg-XL or measuring depth extension 844 Dv |
| 4484811 | 844 Dt-3 | For plug gages \varnothing >60 –80 mm | \varnothing 11.9 mm or \varnothing 17.9 mm As specified, depending on clamping shank \varnothing of holder 844 Dg/Dg-XL or measuring depth extension 844 Dv |
| 4484812 | 844 Dt-3 | For plug gages \varnothing >80 –100 mm | \varnothing 11.9 mm or \varnothing 17.9 mm As specified, depending on clamping shank \varnothing of holder 844 Dg/Dg-XL or measuring depth extension 844 Dv |
| 4484813 | 844 Dt-3 | For plug gages \varnothing >100 –150 mm | \varnothing 11.9 mm or \varnothing 17.9 mm As specified, depending on clamping shank \varnothing of holder 844 Dg/Dg-XL or measuring depth extension 844 Dv |

| Order no. | $\varnothing D$ | L mm | Stop surfaces $\varnothing A$ |
|-----------|----------------------------|--|-------------------------------|
| | | | mm |
| 4484810 | Diameter plug gage + 14 mm | Individual adaptation/specification in case to plug gage | Diameter plug gage + 7 mm |
| 4484811 | Diameter plug gage + 14 mm | Individual adaptation/specification in case to plug gage | Diameter plug gage + 7 mm |
| 4484812 | Diameter plug gage + 14 mm | Individual adaptation/specification in case to plug gage | Diameter plug gage + 7 mm |
| 4484813 | Diameter plug gage + 14 mm | Individual adaptation/specification in case to plug gage | Diameter plug gage + 7 mm |

Dimentron® plug gages

The Dimentron® system - built for performance



Dimentron® plug assembly — shown with *Maxµm*® III indicator, housing and handle

The Dimentron plug gage, which makes up the plug body, the panto-assembly, its contacts and transfer rod, is the measuring system comprising the Dimentron plug. It can be interchanged by simply unscrewing it from the display assembly.

The **plug body** is made of tough hardened 440 stainless steel, tempered and ground. Introduction into the bore is facilitated with 52-56 HRC hardness guide.

Standard **contacts** are made of tungsten carbide and based on the bore diameter range, come in two possible radii. Other contact materials are available based on the part being measured. Diamond, ruby or hard-chrome-covered contacts are also available. Diamond or ruby contacts are suggested for soft aluminum or highly wearing applications; hard chromed ones (1000 HV) for aluminum and relevant alloys. Also based on the thickness of the surface, cylindrical contact options are available.

Either 2 or 4 steel spring assemblies **form panto-spring assemblies**. The design of the transfer assembly is determined by the diameter of the plug. This panto-design produces true straight-line transfer to the V-rod.

A **transfer rod**, with spherical tungsten carbide tip, slides on a tempered steel V-shaped guide and inclined plane, transferring the measurement to the display device. This unique floating system has been designed and tested to resist for over 10,000,000 measuring cycles.

Though designed for the toughest shop conditions, wear items do occasionally need replacement. Because of the individual components, **service is fast and easy**. All parts are available separately from Mahr and with standard tools, can be replaced in minutes to help maintain up time on the floor.



Special depth gaging applications



Shown with bench stand 2239307 & plug holder 2248358

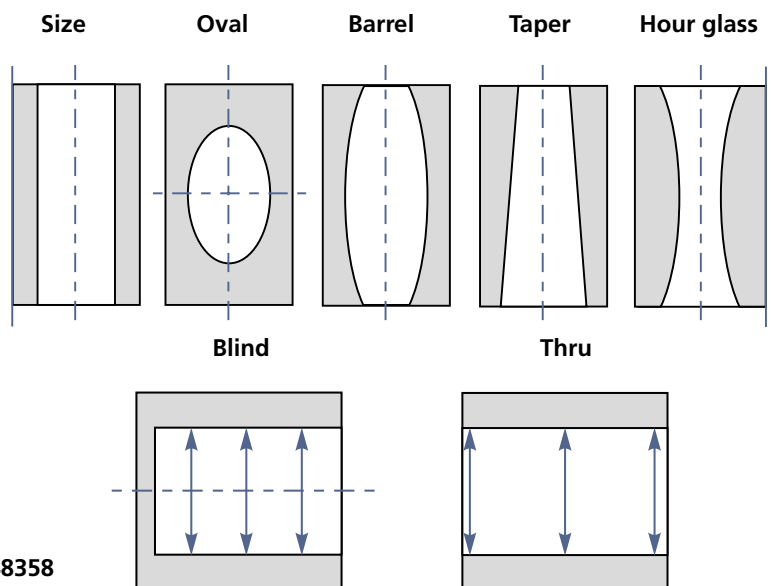

Dimention® plug inside diameter gages

The following table depicts available readouts for Dimention plug inside diameter gages. After making a plug selection, follow the chart for all the components needed to compose a gaging system suited to your application.

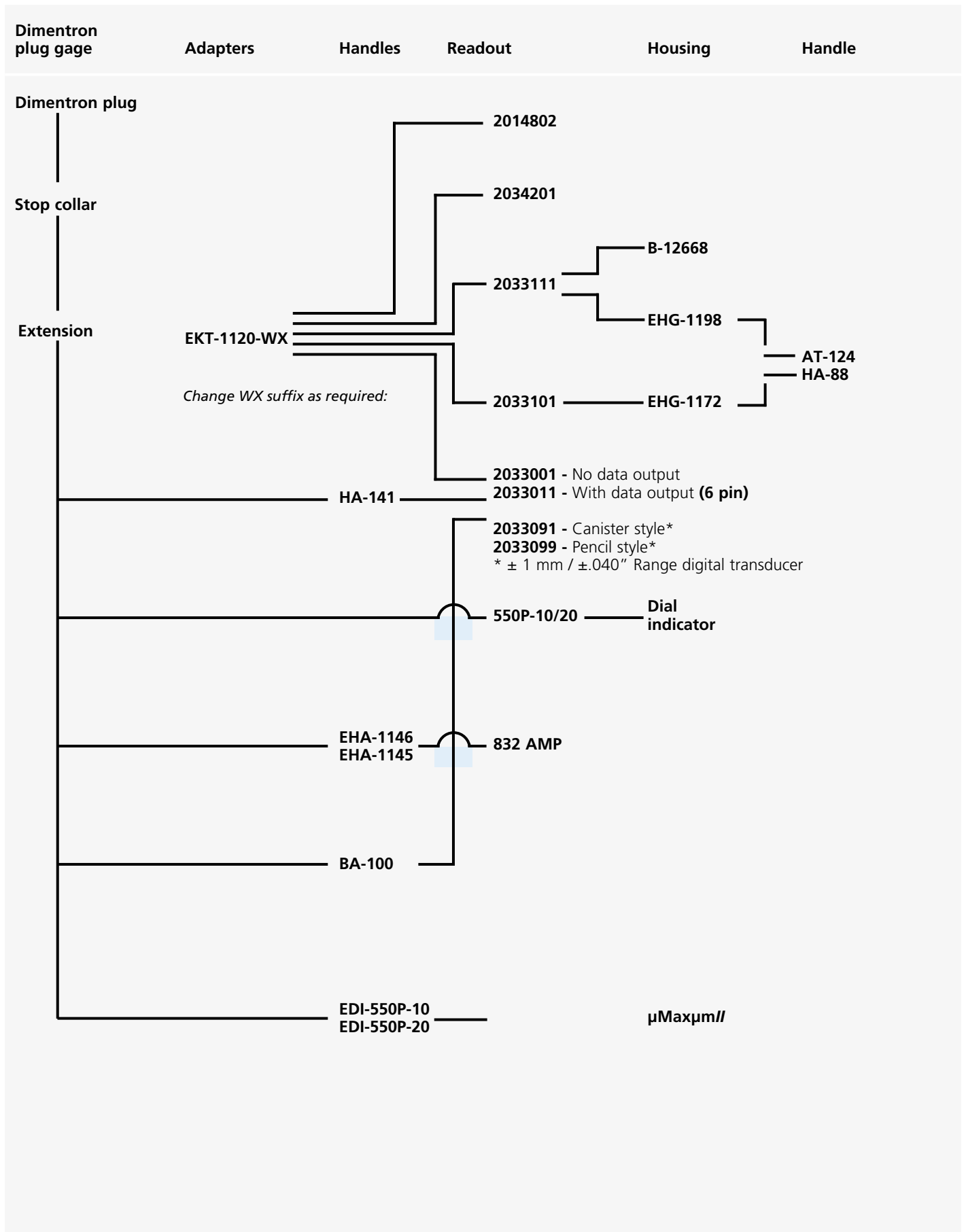

Marameter Dimentron

Indicating plug gage for through hole

FEATURES

- Designed for high production ID gaging
- High chrome content; hardened stainless steel bodies ground precisely for specified size measurement
- Plug tooling interchangeable for quick changeover
- Easy measurement - insert plug into diameter and read (no rocking needed)
- Set to nominal dimension with a single master ring
- Long life
 - Tungsten carbide contacts and V-rod ensure durable motion transfer
 - Open design is conducive to easy rinse cleaning
- Good for determining bore conditions for:
 - Taper
 - Barrel shape
 - Bell mouth
 - 2-point out-of-round
- Stop collars available for all standard sizes
- Captive V-rod design



TECHNICAL DATA

| Order no. | Product type | Nominal size | | Max. tolerance | Max. tolerance | Max. tolerance | Max. tolerance | Max. tolerance | Max. tolerance | Max. tolerance | Max. tolerance |
|-----------|--------------|-------------------|----------------------|----------------|----------------|----------------|----------------|----------------|----------------|----------------|----------------|
| | | mm | inch | M01 | 050 | M02 | 100 | M05 | 200 | M08 | 400 |
| 2057604 | Dimentron | 3.200 -5.500 | .12500 -.21700 | ± 0.025 | ± .0010 | ± 0.038 | ± .0015 | | | | |
| 2057605 | Dimentron | 5.001 -8.200 | .21705 -.03220 | ± 0.025 | ± .0010 | ± 0.046 | ± .0018 | ± 0.076 | ± .0030 | | |
| 2057606 | Dimentron | 8.201 -9.500 | 0.3225 -.37500 | ± 0.025 | ± .0010 | ± 0.046 | ± .0018 | ± 0.069 | ± .0027 | ± 0.102 | ± .0040 |
| 2057607 | Dimentron | 9.501 -12.700 | .37505 -.50000 | ± 0.030 | ± .0012 | ± 0.051 | ± .0020 | ± 0.069 | ± .0027 | ± 0.127 | ± .0050 |
| 2057608 | Dimentron | 12.701 -19.050 | .50005 -.75000 | ± 0.038 | ± .0015 | ± 0.058 | ± .0023 | ± 0.086 | ± .0034 | ± 0.137 | ± .0054 |
| 2057609 | Dimentron | 19.051 -25.000 | .75005 -1.00000 | ± 0.038 | ± .0015 | ± 0.069 | ± .0027 | ± 0.102 | ± .0040 | ± 0.165 | ± .0065 |
| 2057610 | Dimentron | 25.001 -38.000 | 1.00005 -1.50000 | ± 0.038 | ± .0015 | ± 0.076 | ± .0030 | ± 0.127 | ± .0050 | ± 0.180 | ± .0071 |
| 2057611 | Dimentron | 38.001 -63.5 | 1.50000 - 2.50000 | | | ± 0.076 | ± .0030 | ± 0.152 | ± .0060 | ± 0.254 | ± .0100 |
| 2057612 | Dimentron | 63.5 -76.2 | 2.500 -3.000 | | | ± 0.076 | ± .0030 | ± 0.152 | ± .0060 | ± 0.254 | ± .0100 |
| 2057613 | Dimentron | 76.2 -88.9 | 3.000 -3.500 | | | ± 0.076 | ± .0030 | ± 0.152 | ± .0060 | ± 0.254 | ± .0100 |
| 2057614 | Dimentron | 88.9 -101.6 | 3.500 -4.000 | | | ± 0.076 | ± .0030 | ± 0.152 | ± .0060 | ± 0.254 | ± .0100 |
| 2057615 | Dimentron | 101.6 -114.3 | 4.000 -4.500 | | | ± 0.076 | ± .0030 | ± 0.152 | ± .0060 | ± 0.254 | ± .0100 |
| 2057616 | Dimentron | 114.3 -139.7 | 4.500 -5.500 | | | | | ± 0.152 | ± .0060 | ± 0.254 | ± .0100 |
| 2057617 | Dimentron | 139.7 -165.1 | 5.500 -6.500 | | | | | ± 0.152 | ± .0060 | ± 0.254 | ± .0100 |
| 2057618 | Dimentron | 165.1 -203.2 | 6.500 -8.000 | | | | | ± 0.152 | ± .0060 | ± 0.254 | ± .0100 |
| 2057619 | Dimentron | 203.2 -228.6 | 8.000 -9.000 | | | | | ± 0.152 | ± .0060 | ± 0.254 | ± .0100 |

Marameter Dimentron

Indicating plug gage for through hole

| Order no. | Nominal size | | A | Dimension A | | B | Dimension B | |
|---------------------|-------------------|-------------------|------|-------------|-------|------|-------------|------|
| | mm | inch | | mm | inch | | mm | inch |
| 2057604 | 3.200 – 5.500 | .12500 – .21700 | 31.4 | 1.23 | 6.40 | .25 | | |
| 2057605 | 5.001 – 8.200 | .21705 – 0.3220 | 34.8 | 1.37 | 6.50 | .256 | | |
| 2057606 | 8.201 – 9.500 | 0.3225 – .37500 | 34.8 | 1.37 | 6.50 | .256 | | |
| 2057607 | 9.501 – 12.700 | .37505 – .50000 | 35.4 | 1.39 | 13.00 | .512 | | |
| 2057608 | 12.701 – 19.050 | .50005 – .75000 | 35.4 | 1.39 | 13.00 | .512 | | |
| 2057609 | 19.051 – 25.000 | .75005 – 1.00000 | 48.3 | 1.90 | 16.00 | .63 | | |
| 2057610 | 25.001 – 38.000 | 1.00005 – 1.50000 | 48.3 | 1.90 | 16.00 | .63 | | |
| 2057611 | 38.000 – 63.000 | 1.50000 – 2.50000 | 46.7 | 1.84 | 19 | .748 | | |
| 2057612– 2057615 | 63.000 – 114.300 | 2.50000 – 4.50000 | 46.7 | 1.84 | 19 | .748 | | |
| 2057616– 2057619 | 114.300 – 228.300 | 4.50000 – 9.00000 | 46.7 | 1.84 | 9.5 | .375 | | |

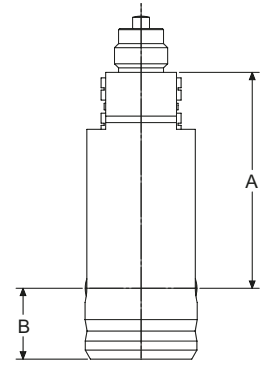

ACCESSORIES

| Order no. | Product name | Type |
|-----------|---|-------------|
| 4337620 | Digital indicator, 0.0005 mm, 12.5 mm | 1086 R |
| 4337624 | Digital indicator, 0.0005 mm, 12.5 mm | 1086 Ri |
| 4337660 | Digital indicator, 0.0005 mm, 12.5 mm | 1087 R |
| 4337663 | Digital indicator, 0.0005 mm, 12.5 mm | 1087 Ri |
| 2050829 | Bore gage handle with indicator 221, grad. .0001" | 550P-10 |
| 2050830 | Bore gage handle with indicator P11, grad. 0.002 mm | 550P-20 |
| 2203139 | Adapter for handle HA-88 | AT-124 |
| 2203140 | Adapter for mounting Maxµm III with protective housing to bench stand BA-26 | AT-125 |
| 2204032 | Protective housing for Maxµm III with output | B-12668 |
| 2204599 | Base with tooling plate, plug to be mounted vertically or horizontally | BA-100 |
| 2051697 | Bore gage handle with digital indicator µMaxum II, res. 0.001mm / .00005" | EDI-550P-10 |
| 2051698 | Bore gage handle with digital indicator µMaxum II, res. 0.0005mm / .00002" | EDI-550P-20 |
| 2213388 | Handle assembly (inductive probe, HA-88 handle, AD-140 adapter) with 1.5m/5ft. straight cable | EHA-1145 |
| 2213389 | Handle assembly (inductive probe, HA-88 handle, AD-140 adapter) with 3m/11ft. coiled cable | EHA-1146 |
| 2214119 | Adapter set to mount Maxµm III indicator with 3/8" stem to a Dimentron plug | EKT-1120-W1 |
| 2214120 | Adapter set to mount Maxµm III indicator with 8 mm stem to a Dimentron plug | EKT-1120-W2 |
| 2214121 | Adapter set to mount dial indicators or µMaxum II with 3/8" stem to a Dimentron plug | EKT-1120-W3 |
| 2214122 | Adapter set to mount dial indicators or µMaxum II with 8 mm stem to a Dimentron plug | EKT-1120-W4 |
| 2214124 | Adapter set to mount dial comparators 1002 – 1010 with 8 mm stem to a Dimentron plug | EKT-1120-W6 |
| 2218595 | Depth extension 50 mm / 1.97" for plug diameter 9.5 – 19.05 mm / .375 – .75" | EX-204 |
| 2218596 | Depth extension 100 mm / 3.94" for plug diameter 9.5 – 19.05 mm / .375 – .75" | EX-205 |
| 2218597 | Depth extension 200 mm / 7.87" for plug diameter 9.5 – 19.05 mm / .375 – .75" | EX-206 |
| 2218600 | Depth extension 50 mm / 1.97" for plug diameter 19.05 mm / .75" and above | EX-210 |
| 2218601 | Depth extension 100 mm / 3.94" for plug diameter 19.05 mm / .75" and above | EX-211 |
| 2218602 | Depth extension 200 mm / 7.87" for plug diameter 19.05 mm / .75" and above | EX-212 |
| 2220037 | Handle for Maxµm III digital transducers | HA-141 |
| 2220100 | Handle to be mounted on protective housings EHG-1172 and EHG-1198 via adapter AT-124 | HA-88 |
| 2033101 | Inductive digital comparator, ±1 mm/± .040", no output | Maxµm III |
| 2033111 | Inductive digital comparator, ±1 mm/± .040", with output (6-pin) | Maxµm III |
| 2033201 | Inductive digital comparator, ± mm/± .040", with data output (6-pin), "0" at 6 o'clock position | Maxµm III |



Maxµm III



1086 R; 1086 R-HR; 1086 ZR



1086 Ri



1087 R; 1087 R-HR; 1087 ZR



1087 Ri



EDI-550P-10



HA-141



BA-100

Marameter Dimentron

Indicating plug gage for through hole

FEATURES

- Designed for high production ID gaging
- High chrome content; hardened stainless steel bodies ground precisely for specified size measurement
- Plug tooling interchangeable for quick changeover
- Easy measurement - insert plug into diameter and read (no rocking needed)
- Set to nominal dimension with a single master ring
- Long life
 - Tungsten carbide contacts and V-rod ensure durable motion transfer
 - Open design is conducive to easy rinse cleaning
- Good for determining bore conditions for:
 - Taper
 - Barrel shape
 - Bell mouth
 - 2-point out-of-round
- Stop collars available for all standard sizes
- Captive V-rod design

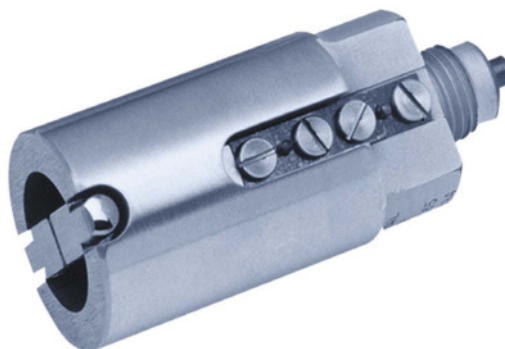

TECHNICAL DATA

| Order no. | Product type | Nominal size | Nominal size | Max. tolerance | Max. tolerance | Max. tolerance | Max. tolerance | Max. tolerance | Max. tolerance | Max. tolerance | Max. tolerance |
|-----------|--------------|--------------|--------------|----------------|----------------|----------------|----------------|----------------|----------------|----------------|----------------|
| | | | | M01 | 050 | M02 | 100 | M05 | 200 | M08 | 400 |
| | | mm | inch | mm | inch | mm | inch | mm | inch | mm | inch |
| 2057620 | Dimentron | 3.180 | .12500 | ± 0.025 | ± .0010 | ± 0.038 | ± .0015 | - | - | - | - |
| | | -3.620 | -.14260 | | | | | | | | |
| | | 3.621 | .14265 | ± 0.025 | ± .0010 | ± 0.046 | ± .0018 | ± 0.076 | ± .0030 | - | - |
| | | -5.500 | -.21700 | | | | | | | | |
| 2057621 | Dimentron | 5.501 | .21705 | ± 0.025 | ± .0010 | ± 0.046 | ± .0018 | ± 0.069 | ± .0027 | ± 0.102 | ± .0040 |
| | | -7.940 | -.31250 | | | | | | | | |
| | | 7.941 | .31255 | ± 0.030 | ± .0012 | ± 0.051 | ± .0020 | ± 0.069 | ± .0027 | ± 0.127 | ± .0050 |
| | | -8.200 | -.32200 | | | | | | | | |
| 2057622 | Dimentron | 8.201 | .32205 | ± 0.030 | ± .0012 | ± 0.051 | ± .0020 | ± 0.069 | ± .0027 | ± 0.127 | ± .0050 |
| | | -9.500 | -.37500 | | | | | | | | |
| 2057623 | Dimentron | 9.501 | .37505 | ± 0.038 | ± .0015 | ± 0.058 | ± .0023 | ± 0.086 | ± .0034 | ± 0.137 | ± .0054 |
| | | -12.700 | -.50000 | | | | | | | | |
| 2057624 | Dimentron | 12.701 | .50005 | ± 0.038 | ± .0015 | ± 0.069 | ± .0027 | ± 0.102 | ± .0040 | ± 0.165 | ± .0065 |
| | | -19.050 | -.75000 | | | | | | | | |
| 2057625 | Dimentron | 19.051 | .75005 | ± 0.038 | ± .0015 | ± 0.076 | ± .0030 | ± 0.127 | ± .0050 | ± 0.180 | ± .0071 |
| | | -25.400 | -1.00000 | | | | | | | | |
| 2057626 | Dimentron | 25.401 | 1.00005 | ± 0.038 | ± .0015 | ± 0.076 | ± .0030 | ± 0.152 | ± .0060 | ± 0.221 | ± .0087 |
| | | -38.000 | -1.50000 | | | | | | | | |
| 2057627 | Dimentron | 38.001 | 1.50000 | - | - | ± 0.076 | ± .0030 | ± 0.152 | ± .0060 | ± 0.254 | ± .0100 |
| | | - 63.5 | 2.50000 | | | | | | | | |
| 2057628 | Dimentron | 63.5 | 2.500 | - | - | ± 0.076 | ± .0030 | ± 0.152 | ± .0060 | ± 0.254 | ± .0100 |
| | | -76.2 | -3.000 | | | | | | | | |
| 2057629 | Dimentron | 76.2 | 3.000 | - | - | ± 0.076 | ± .0030 | ± 0.152 | ± .0060 | ± 0.254 | ± .0100 |
| | | -88.9 | -3.500 | | | | | | | | |
| 2057630 | Dimentron | 88.9 | 3.500 | - | - | ± 0.076 | ± .0030 | ± 0.152 | ± .0060 | ± 0.254 | ± .0100 |
| | | -101.6 | -4.000 | | | | | | | | |
| 2057631 | Dimentron | 101.6 | 4.000 | - | - | ± 0.076 | ± .0030 | ± 0.152 | ± .0060 | ± 0.254 | ± .0100 |
| | | -114.3 | -4.500 | | | | | | | | |
| 2057632 | Dimentron | 114.3 | 4.500 | - | - | - | - | ± 0.152 | ± .0060 | ± 0.254 | ± .0100 |
| | | -139.7 | -5.500 | | | | | | | | |
| 2057633 | Dimentron | 139.7 | 5.500 | - | - | - | - | ± 0.152 | ± .0060 | ± 0.254 | ± .0100 |
| | | -165.1 | -6.500 | | | | | | | | |
| 2057634 | Dimentron | 165.1 | 6.500 | - | - | - | - | ± 0.152 | ± .0060 | ± 0.254 | ± .0100 |
| | | -203.2 | -8.000 | | | | | | | | |
| 2057635 | Dimentron | 203.2 | 8.000 | - | - | - | - | ± 0.152 | ± .0060 | ± 0.254 | ± .0100 |
| | | -228.6 | -9.000 | | | | | | | | |

Marameter Dimentron

Indicating plug gage for through hole

| Order no. | Nominal size | | A | Dimension A | | B | Dimension B | |
|---------------------|---------------------------------------|--|------|-------------|------|------|-------------|------|
| | mm | inch | | mm | inch | | mm | inch |
| 2057620 | 3.180 – 5.500 | .12500 – .21700 | 31.4 | 1.23 | 4 | .157 | | |
| 2057621 | 5.501 – 8.200 | .21705 – 0.3220 | 34.8 | 1.37 | 4 | .157 | | |
| 2057622 | 8.201 – 9.500 | 0.3225 – .37500 | 34.8 | 1.37 | 4 | .157 | | |
| 2057623 | 9.501 – 12.700 | .37505 – .50000 | 35.4 | 1.39 | 4 | .157 | | |
| 2057624 | 12.701 – 19.050 | .50005 – .75000 | 35.4 | 1.39 | 4 | .157 | | |
| 2057625 | 19.051 – 25.400 | .75005 – 1.00000 | 48.3 | 1.90 | 4 | .157 | | |
| 2057626 | 25.401 – 38.000 | 1.00005 – 1.50000 | 48.3 | 1.90 | 4 | .157 | | |
| 2057627 | 38.000 – 63.000 | 1.50000 – 2.50000 | 46.7 | 1.84 | 4 | .157 | | |
| 2057628– 2057635 | 63.000 – 114.300 114.300 – 228.300 | 2.50000 – 4.50000 4.50000 – 9.00000 | 46.7 | 1.84 | 4 | .157 | | |

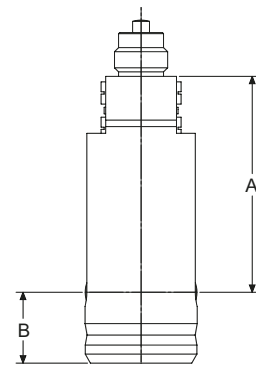

ACCESSORIES

| Order no. | Product name | Type |
|-----------|---|-------------|
| 4337620 | Digital indicator, 0.0005 mm, 12.5 mm | 1086 R |
| 4337624 | Digital indicator, 0.0005 mm, 12.5 mm | 1086 Ri |
| 4337660 | Digital indicator, 0.0005 mm, 12.5 mm | 1087 R |
| 4337663 | Digital indicator, 0.0005 mm, 12.5 mm | 1087 Ri |
| 2050829 | Bore gage handle with indicator 221, grad. .0001" | 550P-10 |
| 2050830 | Bore gage handle with indicator P11, grad. 0.002 mm | 550P-20 |
| 2203139 | Adapter for handle HA-88 | AT-124 |
| 2203140 | Adapter for mounting Maxµm III with protective housing to bench stand BA-26 | AT-125 |
| 2204032 | Protective housing for Maxµm III with output | B-12668 |
| 2204599 | Base with tooling plate, plug to be mounted vertically or horizontally | BA-100 |
| 2051697 | Bore gage handle with digital indicator µMaxum II, res. 0.001mm / .00005" | EDI-550P-10 |
| 2051698 | Bore gage handle with digital indicator µMaxum II, res. 0.0005mm / .00002" | EDI-550P-20 |
| 2213388 | Handle assembly (inductive probe, HA-88 handle, AD-140 adapter) with 1.5m/5ft. straight cable | EHA-1145 |
| 2213389 | Handle assembly (inductive probe, HA-88 handle, AD-140 adapter) with 3m/11ft. coiled cable | EHA-1146 |
| 2214119 | Adapter set to mount Maxµm III indicator with 3/8" stem to a Dimentron plug | EKT-1120-W1 |
| 2214120 | Adapter set to mount Maxµm III indicator with 8 mm stem to a Dimentron plug | EKT-1120-W2 |
| 2214121 | Adapter set to mount dial indicators or µMaxum II with 3/8" stem to a Dimentron plug | EKT-1120-W3 |
| 2214122 | Adapter set to mount dial indicators or µMaxum II with 8 mm stem to a Dimentron plug | EKT-1120-W4 |
| 2214124 | Adapter set to mount dial comparators 1002 – 1010 with 8 mm stem to a Dimentron plug | EKT-1120-W6 |
| 2218595 | Depth extension 50 mm / 1.97" for plug diameter 9.5 – 19.05 mm / .375 – .75" | EX-204 |
| 2218596 | Depth extension 100 mm / 3.94" for plug diameter 9.5 – 19.05 mm / .375 – .75" | EX-205 |
| 2218597 | Depth extension 200 mm / 7.87" for plug diameter 9.5 – 19.05 mm / .375 – .75" | EX-206 |
| 2218600 | Depth extension 50 mm / 1.97" for plug diameter 19.05 mm / .75" and above | EX-210 |
| 2218601 | Depth extension 100 mm / 3.94" for plug diameter 19.05 mm / .75" and above | EX-211 |
| 2218602 | Depth extension 200 mm / 7.87" for plug diameter 19.05 mm / .75" and above | EX-212 |
| 2220037 | Handle for Maxµm III digital transducers | HA-141 |
| 2220100 | Handle to be mounted on protective housings EHG-1172 and EHG-1198 via adapter AT-124 | HA-88 |
| 2033101 | Inductive digital comparator, ±1 mm/± .040", no output | Maxµm III |
| 2033111 | Inductive digital comparator, ±1 mm/± .040", with output (6-pin) | Maxµm III |
| 2033201 | Inductive digital comparator, ± mm/± .040", with data output (6-pin), "0" at 6 o'clock position | Maxµm III |



Maxµm III



1086 R; 1086 R-HR; 1086 ZR



1086 Ri



1087 R; 1087 R-HR; 1087 ZR



1087 Ri



EDI-550P-10



HA-141



BA-100

Marameter Dimentron

Indicating plug gage for through hole

FEATURES

- Designed for high production ID gaging
- High chrome content; hardened stainless steel bodies ground precisely for specified size measurement
- Plug tooling interchangeable for quick changeover
- Easy measurement - insert plug into diameter and read (no rocking needed)
- Set to nominal dimension with a single master ring
- Long life
 - Tungsten carbide contacts and V-rod ensure durable motion transfer
 - Open design is conducive to easy rinse cleaning
- Good for determining bore conditions for:
 - Taper
 - Barrel shape
 - Bell mouth
 - 2-point out-of-round
- Stop collars available for all standard sizes
- Captive V-rod design

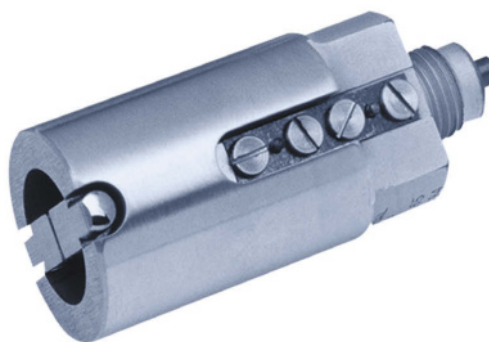

TECHNICAL DATA

| Order no. | Product type | Nominal size | Nominal size | Max. tolerance | Max. tolerance | Max. tolerance | Max. tolerance | Max. tolerance | Max. tolerance | Max. tolerance | Max. tolerance | |
|-----------|--------------|--------------|--------------|----------------|----------------|----------------|----------------|----------------|----------------|----------------|----------------|--|
| | | | | M01 | 050 | M02 | 100 | M05 | 200 | M08 | 400 | |
| | | mm | inch | mm | inch | mm | inch | mm | inch | mm | inch | |
| 2058545 | Dimentron | 5.501 | .21705 | ± 0.025 | ± .0010 | ± 0.046 | ± .0018 | ± 0.069 | ± .0027 | ± 0.102 | ± .0040 | |
| | | -7.940 | -.31250" | | | | | | | | | |
| | | 7.941 | .31255 | ± 0.030 | ± .0012 | ± 0.051 | ± .0020 | ± 0.069 | ± .0027 | ± 0.127 | ± .0050 | |
| 2058546 | Dimentron | 8.201 | .32205 | ± 0.030 | ± .0012 | ± 0.051 | ± .0020 | ± 0.069 | ± .0027 | ± 0.127 | ± .0050 | |
| | | -9.500 | -.37500" | | | | | | | | | |
| 2058547 | Dimentron | 9.501 | .37505 | ± 0.038 | ± .0015 | ± 0.058 | ± .0023 | ± 0.086 | ± .0034 | ± 0.137 | ± .0054 | |
| | | -12.700 | -.50000" | | | | | | | | | |
| 2058548 | Dimentron | 12.701 | .50005 | ± 0.038 | ± .0015 | ± 0.069 | ± .0027 | ± 0.102 | ± .0040 | ± 0.165 | ± .0065 | |
| | | -19.050 | -.75000" | | | | | | | | | |
| 2058549 | Dimentron | 19.051 | .75005 | ± 0.038 | ± .0015 | ± 0.076 | ± .0030 | ± 0.127 | ± .0050 | ± 0.180 | ± .0071 | |
| | | -25.400 | -1.00000" | | | | | | | | | |
| 2058550 | Dimentron | 25.401 | 1.00005 | ± 0.038 | ± .0015 | ± 0.076 | ± .0030 | ± 0.152 | ± .0060 | ± 0.221 | ± .0087 | |
| | | -38.000 | -1.50000" | | | | | | | | | |
| 2058551 | Dimentron | 38.001 | 1.50000 | - | - | ± 0.076 | ± .0030 | ± 0.152 | ± .0060 | ± 0.254 | ± .0100 | |
| | | - 63.5 | 2.50000" | | | | | | | | | |
| 2058552 | Dimentron | 63.5 | 2.500 | - | - | ± 0.076 | ± .0030 | ± 0.152 | ± .0060 | ± 0.254 | ± .0100 | |
| | | -76.2 | -3.000" | | | | | | | | | |
| 2058553 | Dimentron | 76.2 | 3.000 | - | - | ± 0.076 | ± .0030 | ± 0.152 | ± .0060 | ± 0.254 | ± .0100 | |
| | | -88.9 | -3.500" | | | | | | | | | |
| 2058554 | Dimentron | 88.9 | 3.500 | - | - | ± 0.076 | ± .0030 | ± 0.152 | ± .0060 | ± 0.254 | ± .0100 | |
| | | -101.6 | -4.000" | | | | | | | | | |
| 2058555 | Dimentron | 101.6 | 4.000 | - | - | ± 0.076 | ± .0030 | ± 0.152 | ± .0060 | ± 0.254 | ± .0100 | |
| | | -114.3 | -4.500" | | | | | | | | | |
| 2058556 | Dimentron | 114.3 | 4.500 | - | - | - | - | ± 0.152 | ± .0060 | ± 0.254 | ± .0100 | |
| | | -139.7 | -5.500" | | | | | | | | | |
| 2058557 | Dimentron | 139.7 | 5.500 | - | - | - | - | ± 0.152 | ± .0060 | ± 0.254 | ± .0100 | |
| | | -165.1 | -6.500" | | | | | | | | | |
| 2058558 | Dimentron | 165.1 | 6.500 | - | - | - | - | ± 0.152 | ± .0060 | ± 0.254 | ± .0100 | |
| | | -203.2 | -8.000" | | | | | | | | | |
| 2058559 | Dimentron | 203.2 | 8.000 | - | - | - | - | ± 0.152 | ± .0060 | ± 0.254 | ± .0100 | |
| | | -228.6 | -9.000" | | | | | | | | | |

Marameter Dimentron

Indicating plug gage for through hole

| Order no. | Nominal size | | A | Dimension A | | B | Dimension B | |
|---------------------|-------------------|-------------------|------|-------------|------|-----|-------------|------|
| | mm | inch | | mm | inch | | mm | inch |
| 2058545 | 5.501 – 8.200 | .21705 – 0.3220 | 34.8 | 1.37 | 2 | .08 | | |
| | 8.201 – 9.500 | 0.3225 – .37500 | 34.8 | 1.37 | 2 | .08 | | |
| 2058546 | 9.501 – 12.700 | .37505 – .50000 | 35.4 | 1.39 | 2 | .08 | | |
| 2058547 | 12.701 – 19.050 | .50005 – .75000 | 35.4 | 1.39 | 2 | .08 | | |
| 2058548 | 19.051 – 25.400 | .75005 – 1.00000 | 48.3 | 1.90 | 2 | .08 | | |
| 2058549 | 25.401 – 38.000 | 1.00005 – 1.50000 | 48.3 | 1.90 | 2 | .08 | | |
| 2058550 | 38.000 – 63.000 | 1.50000 – 2.50000 | 46.7 | 1.84 | 2 | .08 | | |
| 2058551– 2058555 | 63.000 – 114.300 | 2.50000 – 4.50000 | 46.7 | 1.84 | 2 | .08 | | |
| 2058556– 2058559 | 114.300 – 228.300 | 4.50000 – 9.00000 | 46.7 | 1.84 | 2 | .08 | | |

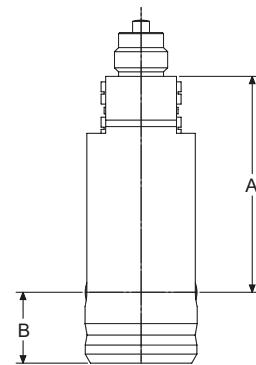

ACCESSORIES

| Order no. | Product name | Type |
|-----------|---|-------------|
| 4337620 | Digital indicator, 0.0005 mm, 12.5 mm | 1086 R |
| 4337624 | Digital indicator, 0.0005 mm, 12.5 mm | 1086 Ri |
| 4337660 | Digital indicator, 0.0005 mm, 12.5 mm | 1087 R |
| 4337663 | Digital indicator, 0.0005 mm, 12.5 mm | 1087 Ri |
| 2050829 | Bore gage handle with indicator 221, grad. .0001" | 550P-10 |
| 2050830 | Bore gage handle with indicator P11, grad. 0.002 mm | 550P-20 |
| 2203139 | Adapter for handle HA-88 | AT-124 |
| 2203140 | Adapter for mounting Maxµm III with protective housing to bench stand BA-26 | AT-125 |
| 2204032 | Protective housing for Maxµm III with output | B-12668 |
| 2204599 | Base with tooling plate, plug to be mounted vertically or horizontally | BA-100 |
| 2051697 | Bore gage handle with digital indicator µMaxum II, res. 0.001mm / .00005" | EDI-550P-10 |
| 2051698 | Bore gage handle with digital indicator µMaxum II, res. 0.0005mm / .00002" | EDI-550P-20 |
| 2213388 | Handle assembly (inductive probe, HA-88 handle, AD-140 adapter) with 1.5m/5ft. straight cable | EHA-1145 |
| 2213389 | Handle assembly (inductive probe, HA-88 handle, AD-140 adapter) with 3m/11ft. coiled cable | EHA-1146 |
| 2214119 | Adapter set to mount Maxµm III indicator with 3/8" stem to a Dimentron plug | EKT-1120-W1 |
| 2214120 | Adapter set to mount Maxµm III indicator with 8 mm stem to a Dimentron plug | EKT-1120-W2 |
| 2214121 | Adapter set to mount dial indicators or µMaxum II with 3/8" stem to a Dimentron plug | EKT-1120-W3 |
| 2214122 | Adapter set to mount dial indicators or µMaxum II with 8 mm stem to a Dimentron plug | EKT-1120-W4 |
| 2214124 | Adapter set to mount dial comparators 1002 – 1010 with 8 mm stem to a Dimentron plug | EKT-1120-W6 |
| 2218595 | Depth extension 50 mm / 1.97" for plug diameter 9.5 – 19.05 mm / .375 – .75" | EX-204 |
| 2218596 | Depth extension 100 mm / 3.94" for plug diameter 9.5 – 19.05 mm / .375 – .75" | EX-205 |
| 2218597 | Depth extension 200 mm / 7.87" for plug diameter 9.5 – 19.05 mm / .375 – .75" | EX-206 |
| 2218600 | Depth extension 50 mm / 1.97" for plug diameter 19.05 mm / .75" and above | EX-210 |
| 2218601 | Depth extension 100 mm / 3.94" for plug diameter 19.05 mm / .75" and above | EX-211 |
| 2218602 | Depth extension 200 mm / 7.87" for plug diameter 19.05 mm / .75" and above | EX-212 |
| 2220037 | Handle for Maxµm III digital transducers | HA-141 |
| 2220100 | Handle to be mounted on protective housings EHG-1172 and EHG-1198 via adapter AT-124 | HA-88 |
| 2033101 | Inductive digital comparator, ±1 mm/± .040", no output | Maxµm III |
| 2033111 | Inductive digital comparator, ±1 mm/± .040", with output (6-pin) | Maxµm III |
| 2033201 | Inductive digital comparator, ± mm/± .040", with data output (6-pin), "0" at 6 o'clock position | Maxµm III |



Maxµm III



1086 R; 1086 Ri; 1086 ZR



1086 Ri



1087 R; 1087 Ri; 1087 ZR



1087 Ri



EDI-550P-10



HA-141



BA-100

Marameter Dimentron

Indicating plug gage for through hole

FEATURES

- Designed for high production ID gaging
- High chrome content; hardened stainless steel bodies ground precisely for specified size measurement
- Plug tooling interchangeable for quick changeover
- Easy measurement - insert plug into diameter and read (no rocking needed)
- Set to nominal dimension with a single master ring
- Long life
 - Tungsten carbide contacts and V-rod ensure durable motion transfer
 - Open design is conducive to easy rinse cleaning
- Good for determining bore conditions for:
 - Taper
 - Barrel shape
 - Bell mouth
 - 2-point out-of-round
- Stop collars available for all standard sizes
- Captive V-rod design



TECHNICAL DATA

| Order no. | Product type | Nominal size | | Max. toleran- | Max. toleran- | Max. toleran- | Max. toleran- | Max. toleran- | Max. toleran- | Max. toleran- | Max. toleran- |
|-----------|--------------|--------------|---------------|---------------|---------------|---------------|---------------|---------------|---------------|---------------|---------------|
| | | mm | inch | ce M01 | ce 050 | ce M02 | ce 100 | ce M05 | ce 200 | ce M08 | ce 400 |
| 2058560 | Dimentron | 5.501 | .21705 | ± 0.025 | ± .0010 | ± 0.046 | ± .0018 | ± 0.069 | ± .0027 | ± 0.102 | ± .0040 |
| | | -7.940 | -.31250" | | | | | | | | |
| | | 7.941 | .31255 | ± 0.030 | ± .0012 | ± 0.051 | ± .0020 | ± 0.069 | ± .0027 | ± 0.127 | ± .0050 |
| 2058561 | Dimentron | -8.200 | -.32200" | | | | | | | | |
| | | 8.201 | .32205 | ± 0.030 | ± .0012 | ± 0.051 | ± .0020 | ± 0.069 | ± .0027 | ± 0.127 | ± .0050 |
| 2058562 | Dimentron | -9.500 | -.37500" | | | | | | | | |
| | | 9.501 | .37505 | ± 0.038 | ± .0015 | ± 0.058 | ± .0023 | ± 0.086 | ± .0034 | ± 0.137 | ± .0054 |
| 2058563 | Dimentron | -12.700 | -.50000" | | | | | | | | |
| | | 12.701 | .50005 | ± 0.038 | ± .0015 | ± 0.069 | ± .0027 | ± 0.102 | ± .0040 | ± 0.165 | ± .0065 |
| 2058564 | Dimentron | -19.050 | -.75000" | | | | | | | | |
| | | 19.051 | .75005 | ± 0.038 | ± .0015 | ± 0.076 | ± .0030 | ± 0.127 | ± .0050 | ± 0.180 | ± .0071 |
| 2058565 | Dimentron | -25.400 | -.1.00000" | | | | | | | | |
| | | 25.401 | 1.00005 | ± 0.038 | ± .0015 | ± 0.076 | ± .0030 | ± 0.152 | ± .0060 | ± 0.221 | ± .0087 |
| 2058566 | Dimentron | -38.000 | -1.50000" | | | | | | | | |
| | | 38.001 | 1.50000 - | - | - | ± 0.076 | ± .0030 | ± 0.152 | ± .0060 | ± 0.254 | ± .0100 |
| 2058567 | Dimentron | -63.5 | -2.50000" | | | | | | | | |
| | | 63.5-76.2 | 2.500-3.000" | - | - | ± 0.076 | ± .0030 | ± 0.152 | ± .0060 | ± 0.254 | ± .0100 |
| 2058568 | Dimentron | -76.2 | -3.000-3.500" | | | | | | | | |
| | | 76.2-88.9 | 3.000-3.500" | - | - | ± 0.076 | ± .0030 | ± 0.152 | ± .0060 | ± 0.254 | ± .0100 |
| 2058569 | Dimentron | -88.9 | -4.000-4.000" | | | | | | | | |
| | | 88.9-101.6 | 3.500-4.000" | - | - | ± 0.076 | ± .0030 | ± 0.152 | ± .0060 | ± 0.254 | ± .0100 |
| 2058570 | Dimentron | -114.3 | -4.500-4.500" | | | | | | | | |
| | | 101.6-114.3 | 4.000-4.500" | - | - | ± 0.076 | ± .0030 | ± 0.152 | ± .0060 | ± 0.254 | ± .0100 |

Marameter Dimentron

Indicating plug gage for through hole

| Order no. | Nominal size | | A | Dimension A | | B | Dimension B | |
|---------------------|------------------|-------------------|------|-------------|------|------|-------------|------|
| | mm | inch | | mm | inch | | mm | inch |
| 2058560 | 5.501 – 8.200 | .21705 – 0.3220 | 34.8 | 1.37 | 0.79 | .031 | | |
| | 8.201 – 9.500 | 0.3225 – .37500 | 34.8 | 1.37 | 0.79 | .031 | | |
| 2058561 | 9.501 – 12.700 | .37505 – .50000 | 35.4 | 1.39 | 0.79 | .031 | | |
| 2058562 | 12.701 – 19.050 | .50005 – .75000 | 35.4 | 1.39 | 0.79 | .031 | | |
| 2058563 | 19.051 – 25.400 | .75005 – 1.00000 | 48.3 | 1.90 | 0.79 | .031 | | |
| 2058564 | 25.401 – 38.000 | 1.00005 – 1.50000 | 48.3 | 1.90 | 0.79 | .031 | | |
| 2058565 | 38.000 – 63.000 | 1.50000 – 2.50000 | 46.7 | 1.84 | 0.79 | .031 | | |
| 2058566– 2058570 | 63.000 – 114.300 | 2.50000 – 4.50000 | 46.7 | 1.84 | 0.79 | .031 | | |

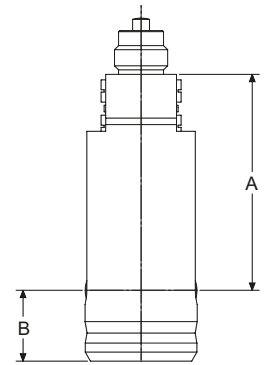

ACCESSORIES

| Order no. | Product name | Type |
|-----------|---|-------------|
| 4337620 | Digital indicator, 0.0005 mm, 12.5 mm | 1086 R |
| 4337624 | Digital indicator, 0.0005 mm, 12.5 mm | 1086 Ri |
| 4337660 | Digital indicator, 0.0005 mm, 12.5 mm | 1087 R |
| 4337663 | Digital indicator, 0.0005 mm, 12.5 mm | 1087 Ri |
| 2050829 | Bore gage handle with indicator 221, grad. .0001" | 550P-10 |
| 2050830 | Bore gage handle with indicator P11, grad. 0.002 mm | 550P-20 |
| 2203139 | Adapter for handle HA-88 | AT-124 |
| 2203140 | Adapter for mounting Maxµm III with protective housing to bench stand BA-26 | AT-125 |
| 2204032 | Protective housing for Maxµm III with output | B-12668 |
| 2204599 | Base with tooling plate, plug to be mounted vertically or horizontally | BA-100 |
| 2051697 | Bore gage handle with digital indicator µMaxum II, res. 0.001mm / .00005" | EDI-550P-10 |
| 2051698 | Bore gage handle with digital indicator µMaxum II, res. 0.0005mm / .00002" | EDI-550P-20 |
| 2213388 | Handle assembly (inductive probe, HA-88 handle, AD-140 adapter) with 1.5m/5ft. straight cable | EHA-1145 |
| 2213389 | Handle assembly (inductive probe, HA-88 handle, AD-140 adapter) with 3m/11ft. coiled cable | EHA-1146 |
| 2214119 | Adapter set to mount Maxµm III indicator with 3/8" stem to a Dimentron plug | EKT-1120-W1 |
| 2214120 | Adapter set to mount Maxµm III indicator with 8 mm stem to a Dimentron plug | EKT-1120-W2 |
| 2214121 | Adapter set to mount dial indicators or µMaxum II with 3/8" stem to a Dimentron plug | EKT-1120-W3 |
| 2214122 | Adapter set to mount dial indicators or µMaxum II with 8 mm stem to a Dimentron plug | EKT-1120-W4 |
| 2214124 | Adapter set to mount dial comparators 1002 – 1010 with 8 mm stem to a Dimentron plug | EKT-1120-W6 |
| 2218595 | Depth extension 50 mm / 1.97" for plug diameter 9.5 – 19.05 mm / .375 – .75" | EX-204 |
| 2218596 | Depth extension 100 mm / 3.94" for plug diameter 9.5 – 19.05 mm / .375 – .75" | EX-205 |
| 2218597 | Depth extension 200 mm / 7.87" for plug diameter 9.5 – 19.05 mm / .375 – .75" | EX-206 |
| 2218600 | Depth extension 50 mm / 1.97" for plug diameter 19.05 mm / .75" and above | EX-210 |
| 2218601 | Depth extension 100 mm / 3.94" for plug diameter 19.05 mm / .75" and above | EX-211 |
| 2218602 | Depth extension 200 mm / 7.87" for plug diameter 19.05 mm / .75" and above | EX-212 |
| 2220037 | Handle for Maxµm III digital transducers | HA-141 |
| 2220100 | Handle to be mounted on protective housings EHG-1172 and EHG-1198 via adapter AT-124 | HA-88 |
| 2033101 | Inductive digital comparator, ±1 mm/± .040", no output | Maxµm III |
| 2033111 | Inductive digital comparator, ±1 mm/± .040", with output (6-pin) | Maxµm III |
| 2033201 | Inductive digital comparator, ± mm/± .040", with data output (6-pin), "0" at 6 o'clock position | Maxµm III |



Maxµm III



1086 R; 1086 R-HR; 1086 ZR



1086 Ri



1087 R; 1087 R-HR; 1087 ZR



1087 Ri



EDI-550P-10



HA-141



BA-100

Marameter | Self-centering inner measuring device 844 K

High-precision comparative measurements of holes

Inside measuring probes from the 844 K family are 2-point comparative measuring instruments used to determine a reversal point in a bore by oscillation. This reversal point equates to the minimum and thus the exact bore diameter.

Measuring process

The measuring value is displayed with analog dial comparators or electronic dial indicators.

Practical tip

An electronic dial indicator such as type 1087 BR or 1087 BRi, offers the major advantage of being able to automatically record the reversal point using the MIN function and display an absolute measuring value on the screen due to the PRESET setting. In addition, you can conveniently and reliably transfer the measuring data to a PC or a CAQ system by data cable or Integrated Wireless technology.

Setting the comparative measuring instrument

Setting rings are used to set the instrument to the respective nominal size.

Typical applications of self-centering inside measuring probes

- Rapid testing of hole diameters

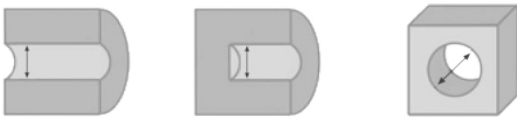

- Determining roundness and cylindricity deviations by rotating and moving to other bore depths



Special advantages

Setting rings are used to set the instrument to the respective nominal size.

- Self-centering in the hole
- Fast determination of reversal point by oscillation
- Measuring value displayed immediately
- Ideal for processing measuring values directly especially when used with digital indicating instruments

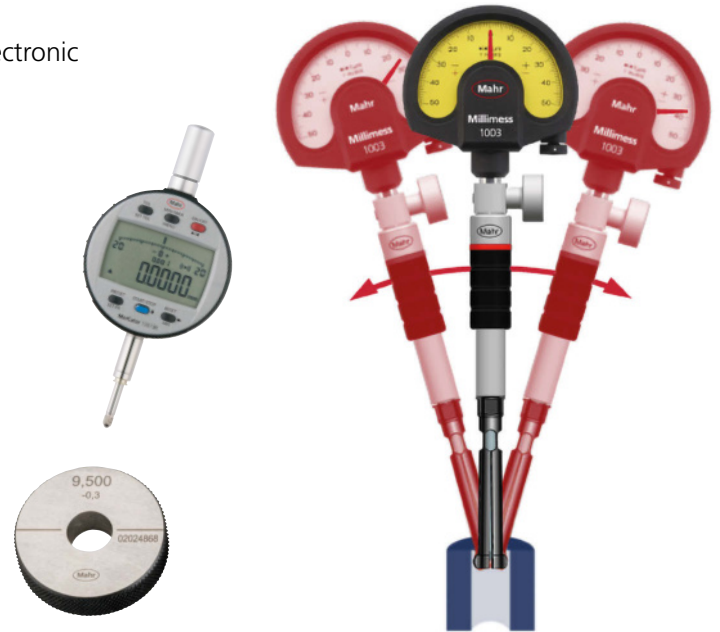

Measuring process

The reversal point (minimum value) is calculated by rocking in a bore.



Marameter | Self-centering inner measuring device 844 K

Inside measuring probe models (split-ball probe)

844 K standard for common hole shapes

- Split-ball probe made of hardened steel
- Hard chrome-plated measuring surfaces

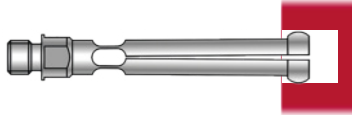

844 KC for common hole shapes with DLC coating

- Split-ball probe made of hardened steel
- Measuring surfaces and inner edges coated with DLC (hard diamond-like coating)
- Enhanced wear protection and very low friction coefficients, therefore ideal for measurements on sensitive or abrasive surfaces
- For common hole shapes

844 KS split-ball probe for bore measurements close to the bottom of the hole

- Split-ball probe made of hardened steel
- Hard chrome plated measuring surfaces

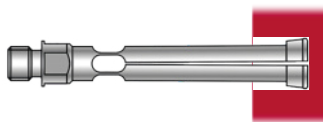

Advantages of DLC coating

- **DLC coating** (diamond-like carbon)
- Extremely hard coating for **very high wear resistance**
- **Extremely low friction coefficient, thus preventing** e.g.
 - Streaking on precision-machined non-ferrous metal surfaces
 - Increased wear on abrasive materials
- DLC coating over entire measuring surfaces including inner contact point of driving needle, for **very high long-term accuracy (linearity)**
- **Visual wear display:** Visible light spot once coating is worn
- **Excellent corrosion prevention**

Ideal equipment for long-term accuracy

Driving needles are inserted in the probe to transfer the measuring movement of the probe head to the indicating instrument. To ensure maximum service life and thus high linearity over a long period of time, Mahr drive needles are generally made of solid carbide.



Modular system

When combined with extensive accessories (indicating instruments, inside measuring probes with driving needle, holders, extensions and right angle attachments), inside measuring probes become precision measuring instruments customized to the measuring task.

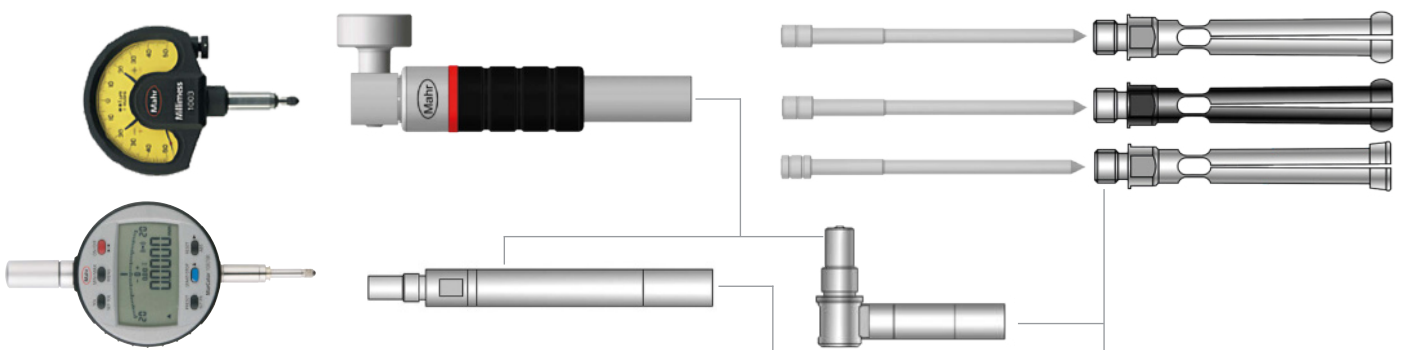

Marameter 844 KC

Self-centering dial bore gage

FEATURES

- Measuring head made in hardened steel, DLC coated
- Constant measuring force as a result of built-in spring, eliminating user influence
- Extensive modular system is composed of measuring head, transfer needle, holder, depth extension, right angle attachments and setting rings



Application: Standard model with DLC-coated surface

- For indicating measurement of diameter and testing for roundness and conicity of bores
- Especially suitable for testing batches
- Determine the reversal point by rocking in the bore



• Benefits of DLC Coating

- DLC = Diamond-Like Carbon
- Extremely high wear resistance, for long service life even on hard or abrasive surfaces
- Reduction of friction, ideal for sensitive surfaces such as non-ferrous metals and aluminium alloys
- Wear indicator, worn areas appear as bright spots in the dark DLC coating

The minimum set of a measuring instrument consists of:

- Measuring head, transfer needle and holder plus indicator unit
- **Package contains:**
Measuring holder 844 Kg, probe, expanding pin, wooden case, excludes indicator

TECHNICAL DATA

| Order no. | Type | Nominal size | Individual probe measuring range | Measuring range | Number of measuring probes | Linearity deviation f_e | Repeatability f_w |
|-----------|-------------|--------------|----------------------------------|-----------------|----------------------------|---------------------------|---------------------|
| | | mm | mm | mm | Piece | | μm |
| 4473105 | 844 KC | 1.00 | 0.95 - 1.15 | 0.95 - 1.55 | 5 | 2 %, min. 1 μm | 1 |
| | | 1.10 | 1.07 - 1.25 | | | | |
| | | 1.20 | 1.17 - 1.35 | | | | |
| | | 1.30 | 1.27 - 1.45 | | | | |
| | | 1.40 | 1.37 - 1.55 | | | | |
| 4473106 | 844 KC | 1.75 | 1.50 - 1.90 | 1.5 - 3.95 | 9 | 1 %, min. 1 μm | 1 |
| | | 2.00 | 1.80 - 2.20 | | | | |
| | | 2.25 | 2.05 - 2.45 | | | | |
| | | 2.50 | 2.30 - 2.70 | | | | |
| | | 2.75 | 2.55 - 2.95 | | | | |
| | | 3.00 | 2.80 - 3.20 | | | | |
| | | 3.25 | 3.05 - 3.45 | | | | |
| | | 3.50 | 3.30 - 3.70 | | | | |
| | | 3.75 | 3.55 - 3.95 | | | | |
| | | 4473107 | 844 KC | | | | |
| 4.50 | 4.20 - 4.80 | | | | | | |
| 5.00 | 4.70 - 5.30 | | | | | | |
| 5.50 | 5.20 - 5.80 | | | | | | |
| 6.00 | 5.70 - 6.30 | | | | | | |
| 6.50 | 6.20 - 6.80 | | | | | | |
| 7.00 | 6.70 - 7.30 | | | | | | |
| 7.50 | 7.20 - 7.80 | | | | | | |
| 8.00 | 7.70 - 8.30 | | | | | | |
| 8.50 | 8.20 - 8.80 | | | | | | |
| 9.00 | 8.70 - 9.30 | | | | | | |
| 9.50 | 9.20 - 9.80 | | | | | | |
| 4473108 | 844 KC | | | 1.75 | 1.50 - 1.90 | 1.5 - 9.8 | 21 |
| | | 2.00 | 1.80 - 2.20 | | | | |
| | | 2.25 | 2.05 - 2.45 | | | | |
| | | 2.50 | 2.30 - 2.70 | | | | |
| | | 2.75 | 2.55 - 2.95 | | | | |
| | | 3.00 | 2.80 - 3.20 | | | | |
| | | 3.25 | 3.05 - 3.45 | | | | |
| | | 3.50 | 3.30 - 3.70 | | | | |
| | | 3.75 | 3.55 - 3.95 | | | | |
| | | 4.00 | 3.70 - 4.30 | | | | |
| | | 4.50 | 4.20 - 4.80 | | | | |
| | | 5.00 | 4.70 - 5.30 | | | | |
| | | 5.50 | 5.20 - 5.80 | | | | |
| | | 6.00 | 5.70 - 6.30 | | | | |
| | | 6.50 | 6.20 - 6.80 | | | | |
| | | 7.00 | 6.70 - 7.30 | | | | |
| 7.50 | 7.20 - 7.80 | | | | | | |
| 8.00 | 7.70 - 8.30 | | | | | | |
| 8.50 | 8.20 - 8.80 | | | | | | |
| 9.00 | 8.70 - 9.30 | | | | | | |
| 9.50 | 9.20 - 9.80 | | | | | | |
| 4473109 | 844 KC | 10.00 | 9.40 - 10.60 | 9.4 - 20.6 | 11 | 1 %, min. 1 μm | 1 |
| | | 11.00 | 10.40 - 11.60 | | | | |
| | | 12.00 | 11.40 - 12.60 | | | | |
| | | 13.00 | 12.40 - 13.60 | | | | |
| | | 14.00 | 13.40 - 14.60 | | | | |
| | | 15.00 | 14.40 - 15.60 | | | | |
| | | 16.00 | 15.40 - 16.60 | | | | |
| | | 17.00 | 16.40 - 17.60 | | | | |
| | | 18.00 | 17.40 - 18.60 | | | | |
| | | 19.00 | 18.40 - 19.60 | | | | |
| | | 20.00 | 19.40 - 20.60 | | | | |

Marameter 844 KC

Self-centering dial bore gage

TECHNICAL DATA

| Order no. | Nominal size | Individual probe measuring range | H1 | L | Measuring depth |
|-----------|--------------|----------------------------------|-------|-------|-----------------|
| | mm | mm | mm | mm | mm |
| 4473105 | 1.00 | 0.95 – 1.15 | 0.6 | 19.50 | 10.5 |
| | 1.10 | 1.07 – 1.25 | 0.6 | 19.50 | 10.5 |
| | 1.20 | 1.17 – 1.35 | 0.6 | 19.50 | 10.5 |
| | 1.30 | 1.27 – 1.45 | 0.6 | 19.50 | 10.5 |
| | 1.40 | 1.37 – 1.55 | 0.6 | 19.50 | 10.5 |
| 4473106 | 1.75 | 1.50 – 1.90 | 0.9 | 25.30 | 16 |
| | 2.00 | 1.80 – 2.20 | 0.9 | 25.30 | 16 |
| | 2.25 | 2.05 – 2.45 | 0.9 | 25.30 | 16 |
| | 2.50 | 2.30 – 2.70 | 1.2 | 30.60 | 21 |
| | 2.75 | 2.55 – 2.95 | 1.2 | 30.60 | 21 |
| | 3.00 | 2.80 – 3.20 | 1.2 | 30.60 | 21 |
| | 3.25 | 3.05 – 3.45 | 1.2 | 30.60 | 21 |
| | 3.50 | 3.30 – 3.70 | 1.2 | 30.60 | 21 |
| | 3.75 | 3.55 – 3.95 | 1.2 | 30.60 | 21 |
| 4473107 | 4.00 | 3.70 – 4.30 | 2.0 | 47.30 | 38 |
| | 4.50 | 4.20 – 4.80 | 2.0 | 47.30 | 38 |
| | 5.00 | 4.70 – 5.30 | 2.0 | 47.30 | 38 |
| | 5.50 | 5.20 – 5.80 | 2.0 | 47.30 | 38 |
| | 6.00 | 5.70 – 6.30 | 2.0 | 47.30 | 38 |
| | 6.50 | 6.20 – 6.80 | 2.0 | 47.30 | 38 |
| | 7.00 | 6.70 – 7.30 | 2.0 | 47.30 | 38 |
| | 7.50 | 7.20 – 7.80 | 2.0 | 47.30 | 38 |
| | 8.00 | 7.70 – 8.30 | 2.0 | 47.30 | 38 |
| | 8.50 | 8.20 – 8.80 | 2.0 | 47.30 | 38 |
| | 9.00 | 8.70 – 9.30 | 2.0 | 47.30 | 38 |
| | 9.50 | 9.20 – 9.80 | 2.0 | 47.30 | 38 |
| 4473108 | 1.75 | 1.50 – 1.90 | 0.9 | 25.30 | 16 |
| | 2.00 | 1.80 – 2.20 | 0.9 | 25.30 | 16 |
| | 2.25 | 2.05 – 2.45 | 0.9 | 25.30 | 16 |
| | 2.50 | 2.30 – 2.70 | 1.2 | 30.60 | 21 |
| | 2.75 | 2.55 – 2.95 | 1.2 | 30.60 | 21 |
| | 3.00 | 2.80 – 3.20 | 1.2 | 30.60 | 21 |
| | 3.25 | 3.05 – 3.45 | 1.2 | 30.60 | 21 |
| | 3.50 | 3.30 – 3.70 | 1.2 | 30.60 | 21 |
| | 3.75 | 3.55 – 3.95 | 1.2 | 30.60 | 21 |
| | 4.00 | 3.70 – 4.30 | 2.0 | 47.30 | 38 |
| | 4.50 | 4.20 – 4.80 | 2.0 | 47.30 | 38 |
| | 5.00 | 4.70 – 5.30 | 2.0 | 47.30 | 38 |
| | 5.50 | 5.20 – 5.80 | 2.0 | 47.30 | 38 |
| | 6.00 | 5.70 – 6.30 | 2.0 | 47.30 | 38 |
| | 6.50 | 6.20 – 6.80 | 2.0 | 47.30 | 38 |
| | 7.00 | 6.70 – 7.30 | 2.0 | 47.30 | 38 |
| | 7.50 | 7.20 – 7.80 | 2.0 | 47.30 | 38 |
| 8.00 | 7.70 – 8.30 | 2.0 | 47.30 | 38 | |
| 8.50 | 8.20 – 8.80 | 2.0 | 47.30 | 38 | |
| 9.00 | 8.70 – 9.30 | 2.0 | 47.30 | 38 | |
| 9.50 | 9.20 – 9.80 | 2.0 | 47.30 | 38 | |
| 4473109 | 10.00 | 9.40 – 10.60 | 3.3 | 48.50 | 45 |
| | 11.00 | 10.40 – 11.60 | 3.3 | 48.50 | 45 |
| | 12.00 | 11.40 – 12.60 | 3.3 | 48.50 | 45 |
| | 13.00 | 12.40 – 13.60 | 3.3 | 48.50 | 45 |
| | 14.00 | 13.40 – 14.60 | 3.3 | 48.50 | 45 |
| | 15.00 | 14.40 – 15.60 | 3.3 | 48.50 | 45 |
| | 16.00 | 15.40 – 16.60 | 3.3 | 48.50 | 45 |
| | 17.00 | 16.40 – 17.60 | 3.3 | 48.50 | 45 |
| | 18.00 | 17.40 – 18.60 | 3.3 | 48.50 | 45 |
| | 19.00 | 18.40 – 19.60 | 3.3 | 48.50 | 45 |
| | 20.00 | 19.40 – 20.60 | 3.3 | 48.50 | 45 |

Marameter 844 KC

Self-centering dial bore gage

ACCESSORIES

| Order no. | Connection thread | Description | Type |
|-----------|-------------------|--|----------|
| 4335000 | | Millimess 0.5 μm , $\pm 25 \mu\text{m}$ | 1002 |
| 4334000 | | Millimess 1 μm , $\pm 50 \mu\text{m}$ | 1003 |
| 4333000 | | Millimess 5 μm , $\pm 130 \mu\text{m}$ | 1004 |
| 4337662 | | Digital indicator, 0.0005 mm, 12.5 mm | 1087 BR |
| 4337664 | | Digital indicator, 0.0005 mm, 12.5 mm | 1087 BRi |
| 4473375 | | Setting rings in set for measuring range 1 –1.4 mm | 844 Ke |
| 4473376 | | Setting rings in set for measuring range 1.75 –3.75 mm | 844 Ke |
| 4473377 | | Setting rings in set for measuring range 4 –9.5 mm | 844 Ke |
| 4473378 | | Setting rings in set for measuring range 1.75 –9.5 mm | 844 Ke |
| 4473379 | | Setting rings in set for measuring range 10 –20 mm | 844 Ke |
| 4473400 | M6 x 0.75 | Holder for indicator, $\varnothing 8 \text{ mm}$ / M6 x 0.75 | 844 Kg |
| 4473401 | M6 x 0.75 | Holder for indicator, $\varnothing 8 \text{ mm}$ / M6 x 0.75 | 844 Kga |
| 4473402 | M6 x 0.75 | Holder for indicator, $\varnothing .375''$ / M6 x 0.75 | 844 Kgz |
| 4473405 | M6 x 0.75 | Extension for measuring depth, length 50 mm | 844 Kv |
| 4473406 | M6 x 0.75 | Extension for measuring depth, length 100 mm | 844 Kv |
| 4473407 | M6 x 0.75 | Extension for measuring depth, length 250 mm | 844 Kv |
| 4473409 | M6 x 0.75 | Right angle attachment, M6 x 0.75 | 844 Kw |



1004



1003



1002



1087 BR



844 Ke



844 Kg;844 Kgz



844 Kga



844 Kv

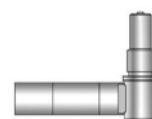

844 Dw;844 Kw

Marameter 844 K

Self-centering dial bore gage

FEATURES

- Measuring head made of hardened steel, hard chrome plated
- Constant measuring force as a result of built-in spring, eliminating user influence
- Extensive modular system is composed of measuring head, transfer needle, holder, depth extension, right angle attachments and setting rings



Application: Standard model

- For indicating measurement of diameter and testing for roundness and conicity of bores
- Especially suitable for testing batches
- Determine the reversal point by rocking in the bore



The minimum set of a measuring instrument consists of:

- Measuring head, transfer needle and holder plus indicator unit
- **Package contains:** Measuring holder 844 Kg, probe, expanding pin, wooden case, excludes indicator

TECHNICAL DATA

| Order no. | Type | Nominal size mm | Individual probe measuring range mm | Measuring range mm | Number of mea- suring probes Piece | Linearity deviation f_e | Repeatability f_w μm |
|-----------|-------------|--------------------|---|--------------------------|--|------------------------------|--------------------------------------|
| 4473005 | 844 K | 1.00 | 0.95 - 1.15 | 0.95 - 1.55 | 5 | 2 %, min. 1 μm | 1 |
| | | 1.10 | 1.07 - 1.25 | | | | |
| | | 1.20 | 1.17 - 1.35 | | | | |
| | | 1.30 | 1.27 - 1.45 | | | | |
| | | 1.40 | 1.37 - 1.55 | | | | |
| 4473006 | 844 K | 1.75 | 1.50 - 1.90 | 1.5 - 3.95 | 9 | 1 %, min. 1 μm | 1 |
| | | 2.00 | 1.80 - 2.20 | | | | |
| | | 2.25 | 2.05 - 2.45 | | | | |
| | | 2.50 | 2.30 - 2.70 | | | | |
| | | 2.75 | 2.55 - 2.95 | | | | |
| | | 3.00 | 2.80 - 3.20 | | | | |
| | | 3.25 | 3.05 - 3.45 | | | | |
| | | 3.50 | 3.30 - 3.70 | | | | |
| 4473007 | 844 K | 4.00 | 3.70 - 4.30 | 3.7 - 9.8 | 12 | 1 %, min. 1 μm | 1 |
| | | 4.50 | 4.20 - 4.80 | | | | |
| | | 5.00 | 4.70 - 5.30 | | | | |
| | | 5.50 | 5.20 - 5.80 | | | | |
| | | 6.00 | 5.70 - 6.30 | | | | |
| | | 6.50 | 6.20 - 6.80 | | | | |
| | | 7.00 | 6.70 - 7.30 | | | | |
| | | 7.50 | 7.20 - 7.80 | | | | |
| | | 8.00 | 7.70 - 8.30 | | | | |
| | | 8.50 | 8.20 - 8.80 | | | | |
| | | 9.00 | 8.70 - 9.30 | | | | |
| 4473008 | 844 K | 1.75 | 1.50 - 1.90 | 1.5 - 9.8 | 21 | 1 %, min. 1 μm | 1 |
| | | 2.00 | 1.80 - 2.20 | | | | |
| | | 2.25 | 2.05 - 2.45 | | | | |
| | | 2.50 | 2.30 - 2.70 | | | | |
| | | 2.75 | 2.55 - 2.95 | | | | |
| | | 3.00 | 2.80 - 3.20 | | | | |
| | | 3.25 | 3.05 - 3.45 | | | | |
| | | 3.50 | 3.30 - 3.70 | | | | |
| | | 3.75 | 3.55 - 3.95 | | | | |
| | | 4.00 | 3.70 - 4.30 | | | | |
| | | 4.50 | 4.20 - 4.80 | | | | |
| | | 5.00 | 4.70 - 5.30 | | | | |
| | | 5.50 | 5.20 - 5.80 | | | | |
| | | 6.00 | 5.70 - 6.30 | | | | |
| 6.50 | 6.20 - 6.80 | | | | | | |
| 7.00 | 6.70 - 7.30 | | | | | | |
| 7.50 | 7.20 - 7.80 | | | | | | |
| 8.00 | 7.70 - 8.30 | | | | | | |
| 8.50 | 8.20 - 8.80 | | | | | | |
| 9.00 | 8.70 - 9.30 | | | | | | |
| 9.50 | 9.20 - 9.80 | | | | | | |
| 4473009 | 844 K | 10.00 | 9.40 - 10.60 | 9.4 - 20.6 | 11 | 1 %, min. 1 μm | 1 |
| | | 11.00 | 10.40 - 11.60 | | | | |
| | | 12.00 | 11.40 - 12.60 | | | | |
| | | 13.00 | 12.40 - 13.60 | | | | |
| | | 14.00 | 13.40 - 14.60 | | | | |
| | | 15.00 | 14.40 - 15.60 | | | | |
| | | 16.00 | 15.40 - 16.60 | | | | |
| | | 17.00 | 16.40 - 17.60 | | | | |
| | | 18.00 | 17.40 - 18.60 | | | | |
| | | 19.00 | 18.40 - 19.60 | | | | |
| | | 20.00 | 19.40 - 20.60 | | | | |

Marameter 844 K

Self-centering dial bore gage

TECHNICAL DATA

| Order no. | Nominal size | Individual probe measuring range | H1 | L | Measuring depth |
|-----------|--------------|----------------------------------|-------|-------|-----------------|
| | mm | mm | mm | mm | mm |
| 4473005 | 1.00 | 0.95 – 1.15 | 0.6 | 19.50 | 10.5 |
| | 1.10 | 1.07 – 1.25 | 0.6 | 19.50 | 10.5 |
| | 1.20 | 1.17 – 1.35 | 0.6 | 19.50 | 10.5 |
| | 1.30 | 1.27 – 1.45 | 0.6 | 19.50 | 10.5 |
| | 1.40 | 1.37 – 1.55 | 0.6 | 19.50 | 10.5 |
| 4473006 | 1.75 | 1.50 – 1.90 | 0.9 | 25.30 | 16 |
| | 2.00 | 1.80 – 2.20 | 0.9 | 25.30 | 16 |
| | 2.25 | 2.05 – 2.45 | 0.9 | 25.30 | 16 |
| | 2.50 | 2.30 – 2.70 | 1.2 | 30.60 | 21 |
| | 2.75 | 2.55 – 2.95 | 1.2 | 30.60 | 21 |
| | 3.00 | 2.80 – 3.20 | 1.2 | 30.60 | 21 |
| | 3.25 | 3.05 – 3.45 | 1.2 | 30.60 | 21 |
| | 3.50 | 3.30 – 3.70 | 1.2 | 30.60 | 21 |
| | 3.75 | 3.55 – 3.95 | 1.2 | 30.60 | 21 |
| 4473007 | 4.00 | 3.70 – 4.30 | 2.0 | 47.30 | 38 |
| | 4.50 | 4.20 – 4.80 | 2.0 | 47.30 | 38 |
| | 5.00 | 4.70 – 5.30 | 2.0 | 47.30 | 38 |
| | 5.50 | 5.20 – 5.80 | 2.0 | 47.30 | 38 |
| | 6.00 | 5.70 – 6.30 | 2.0 | 47.30 | 38 |
| | 6.50 | 6.20 – 6.80 | 2.0 | 47.30 | 38 |
| | 7.00 | 6.70 – 7.30 | 2.0 | 47.30 | 38 |
| | 7.50 | 7.20 – 7.80 | 2.0 | 47.30 | 38 |
| | 8.00 | 7.70 – 8.30 | 2.0 | 47.30 | 38 |
| | 8.50 | 8.20 – 8.80 | 2.0 | 47.30 | 38 |
| | 9.00 | 8.70 – 9.30 | 2.0 | 47.30 | 38 |
| 4473008 | 1.75 | 1.50 – 1.90 | 0.9 | 25.30 | 16 |
| | 2.00 | 1.80 – 2.20 | 0.9 | 25.30 | 16 |
| | 2.25 | 2.05 – 2.45 | 0.9 | 25.30 | 16 |
| | 2.50 | 2.30 – 2.70 | 1.2 | 30.60 | 21 |
| | 2.75 | 2.55 – 2.95 | 1.2 | 30.60 | 21 |
| | 3.00 | 2.80 – 3.20 | 1.2 | 30.60 | 21 |
| | 3.25 | 3.05 – 3.45 | 1.2 | 30.60 | 21 |
| | 3.50 | 3.30 – 3.70 | 1.2 | 30.60 | 21 |
| | 3.75 | 3.55 – 3.95 | 1.2 | 30.60 | 21 |
| | 4.00 | 3.70 – 4.30 | 2.0 | 47.30 | 38 |
| | 4.50 | 4.20 – 4.80 | 2.0 | 47.30 | 38 |
| | 5.00 | 4.70 – 5.30 | 2.0 | 47.30 | 38 |
| | 5.50 | 5.20 – 5.80 | 2.0 | 47.30 | 38 |
| | 6.00 | 5.70 – 6.30 | 2.0 | 47.30 | 38 |
| | 6.50 | 6.20 – 6.80 | 2.0 | 47.30 | 38 |
| 7.00 | 6.70 – 7.30 | 2.0 | 47.30 | 38 | |
| 7.50 | 7.20 – 7.80 | 2.0 | 47.30 | 38 | |
| 8.00 | 7.70 – 8.30 | 2.0 | 47.30 | 38 | |
| 8.50 | 8.20 – 8.80 | 2.0 | 47.30 | 38 | |
| 9.00 | 8.70 – 9.30 | 2.0 | 47.30 | 38 | |
| 9.50 | 9.20 – 9.80 | 2.0 | 47.30 | 38 | |
| 4473009 | 10.00 | 9.40 – 10.60 | 3.3 | 48.50 | 45 |
| | 11.00 | 10.40 – 11.60 | 3.3 | 48.50 | 45 |
| | 12.00 | 11.40 – 12.60 | 3.3 | 48.50 | 45 |
| | 13.00 | 12.40 – 13.60 | 3.3 | 48.50 | 45 |
| | 14.00 | 13.40 – 14.60 | 3.3 | 48.50 | 45 |
| | 15.00 | 14.40 – 15.60 | 3.3 | 48.50 | 45 |
| | 16.00 | 15.40 – 16.60 | 3.3 | 48.50 | 45 |
| | 17.00 | 16.40 – 17.60 | 3.3 | 48.50 | 45 |
| | 18.00 | 17.40 – 18.60 | 3.3 | 48.50 | 45 |
| | 19.00 | 18.40 – 19.60 | 3.3 | 48.50 | 45 |
| | 20.00 | 19.40 – 20.60 | 3.3 | 48.50 | 45 |

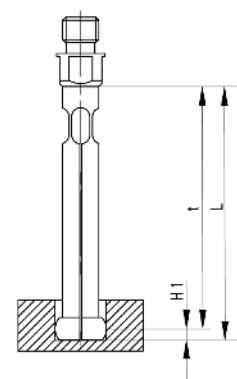

Marameter 844 K

Self-centering dial bore gage

ACCESSORIES

| Order no. | Connection thread | Description | Type |
|-----------|-------------------|--|----------|
| 4335000 | | Millimess 0.5 μm , $\pm 25 \mu\text{m}$ | 1002 |
| 4334000 | | Millimess 1 μm , $\pm 50 \mu\text{m}$ | 1003 |
| 4333000 | | Millimess 5 μm , $\pm 130 \mu\text{m}$ | 1004 |
| 4337662 | | Digital indicator, 0.0005 mm, 12.5 mm | 1087 BR |
| 4337664 | | Digital indicator, 0.0005 mm, 12.5 mm | 1087 BRi |
| 4473375 | | Setting rings in set for measuring range 1 –1.4 mm | 844 Ke |
| 4473376 | | Setting rings in set for measuring range 1.75 –3.75 mm | 844 Ke |
| 4473377 | | Setting rings in set for measuring range 4 –9.5 mm | 844 Ke |
| 4473378 | | Setting rings in set for measuring range 1.75 –9.5 mm | 844 Ke |
| 4473379 | | Setting rings in set for measuring range 10 –20 mm | 844 Ke |
| 4473400 | M6 x 0.75 | Holder for indicator, $\varnothing 8 \text{ mm}$ / M6 x 0.75 | 844 Kg |
| 4473401 | M6 x 0.75 | Holder for indicator, $\varnothing 8 \text{ mm}$ / M6 x 0.75 | 844 Kga |
| 4473402 | M6 x 0.75 | Holder for indicator, $\varnothing .375''$ / M6 x 0.75 | 844 Kgz |
| 4473405 | M6 x 0.75 | Extension for measuring depth, length 50 mm | 844 Kv |
| 4473406 | M6 x 0.75 | 8Extension for measuring depth, length 100 mm | 844 Kv |
| 4473407 | M6 x 0.75 | Extension for measuring depth, length 250 mm | 844 Kv |
| 4473409 | M6 x 0.75 | Right angle attachment, M6 x 0.75 | 844 Kw |



1004



1003



1002



1087 BR



844 Ke



844 Kg;844 Kgz



844 Kga



844 Kv

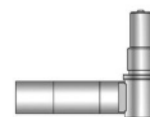

844 Dw;844 Kw

Marameter 844 KS

Self-centering dial bore gage

FEATURES

- Measuring head made of hardened steel, hard chrome plated
- Constant measuring force as a result of built-in spring, eliminating user influence
- Extensive modular system is composed of measuring head, transfer needle, holder, depth extension, right angle attachments and setting rings

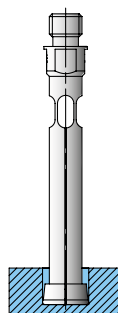

Application: Model for blind holes

- For measurements near to the bottom of bores
- For indicating measurement of diameter and testing for roundness and conicity of bores
- Especially suitable for testing batches
- Determine the reversal point by rocking in the bore

The minimum set of a measuring instrument consists of:

- Measuring head, transfer needle and holder plus indicator unit
- **Package contains:** Measuring holder 844 Kg, probe, expanding pin, wooden case, excludes indicator

TECHNICAL DATA

| Order no. | Type | Nominal size mm | Individual probe measuring range mm | Measuring range mm | Number of measuring probes Piece | Linearity deviation f_e | Repeatability f_w μm |
|-----------|--------|--------------------|--|-----------------------|-------------------------------------|---------------------------|--------------------------------------|
| 4473207 | 844 KS | 4.00 | 3.70 – 4.30 | 3.7 – 9.8 | 12 | 1 %, min. 1 μm | 1 |
| | | 4.50 | 4.20 – 4.80 | | | | |
| | | 5.00 | 4.70 – 5.30 | | | | |
| | | 5.50 | 5.20 – 5.80 | | | | |
| | | 6.00 | 5.70 – 6.30 | | | | |
| | | 6.50 | 6.20 – 6.80 | | | | |
| | | 7.00 | 6.70 – 7.30 | | | | |
| | | 7.50 | 7.20 – 7.80 | | | | |
| | | 8.00 | 7.70 – 8.30 | | | | |
| | | 8.50 | 8.20 – 8.80 | | | | |
| | | 9.00 | 8.70 – 9.30 | | | | |
| | | 9.50 | 9.20 – 9.80 | | | | |
| 4473209 | 844 KS | 10.00 | 9.40 – 10.60 | 9.4 – 9.8 | 11 | 1 %, min. 1 μm | 1 |
| | | 11.00 | 10.40 – 11.60 | | | | |
| | | 12.00 | 11.40 – 12.60 | | | | |
| | | 13.00 | 12.40 – 13.60 | | | | |
| | | 14.00 | 13.40 – 14.60 | | | | |
| | | 15.00 | 14.40 – 15.60 | | | | |
| | | 16.00 | 15.40 – 16.60 | | | | |
| | | 17.00 | 16.40 – 17.60 | | | | |
| | | 18.00 | 17.40 – 18.60 | | | | |
| | | 19.00 | 18.40 – 19.60 | | | | |
| | | 20.00 | 19.40 – 20.60 | | | | |

| Order no. | Nominal size mm | Individual probe measuring range mm | H1 mm | L mm | Measuring depth mm |
|-----------|--------------------|--|----------|---------|-----------------------|
| 4473207 | 4.00 | 3.70 – 4.30 | 0.5 | 47.30 | 38 |
| | 4.50 | 4.20 – 4.80 | 0.5 | 47.30 | 38 |
| | 5.00 | 4.70 – 5.30 | 0.5 | 47.30 | 38 |
| | 5.50 | 5.20 – 5.80 | 0.5 | 47.30 | 38 |
| | 6.00 | 5.70 – 6.30 | 0.5 | 47.30 | 38 |
| | 6.50 | 6.20 – 6.80 | 0.5 | 47.30 | 38 |
| | 7.00 | 6.70 – 7.30 | 0.5 | 47.30 | 38 |
| | 7.50 | 7.20 – 7.80 | 0.5 | 47.30 | 38 |
| | 8.00 | 7.70 – 8.30 | 0.5 | 47.30 | 38 |
| | 8.50 | 8.20 – 8.80 | 1.0 | 48.50 | 45 |
| | 9.00 | 8.70 – 9.30 | 1.0 | 48.50 | 45 |
| | 9.50 | 9.20 – 9.80 | 1.0 | 48.50 | 45 |
| 4473209 | 10.00 | 9.40 – 10.60 | 1.0 | 48.50 | 45 |
| | 11.00 | 10.40 – 11.60 | 1.0 | 48.50 | 45 |
| | 12.00 | 11.40 – 12.60 | 1.0 | 48.50 | 45 |
| | 13.00 | 12.40 – 13.60 | 1.0 | 48.50 | 45 |
| | 14.00 | 13.40 – 14.60 | 1.0 | 48.50 | 45 |
| | 15.00 | 14.40 – 15.60 | 1.0 | 48.50 | 45 |
| | 16.00 | 15.40 – 16.60 | 1.0 | 48.50 | 45 |
| | 17.00 | 16.40 – 17.60 | 1.0 | 48.50 | 45 |
| | 18.00 | 17.40 – 18.60 | 1.0 | 48.50 | 45 |
| | 19.00 | 18.40 – 19.60 | 1.0 | 48.50 | 45 |
| | 20.00 | 19.40 – 20.60 | 1.0 | 48.50 | 45 |

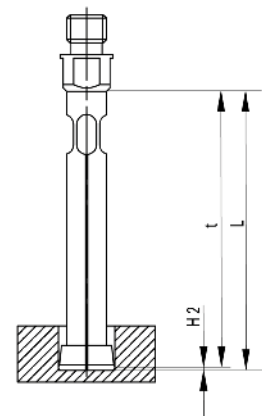

Marameter 844 KS

Self-centering dial bore gage

ACCESSORIES

| Order no. | Connection thread | Description | Type |
|-----------|-------------------|--|----------|
| 4335000 | | Millimess 0.5 μm , $\pm 25 \mu\text{m}$ | 1002 |
| 4334000 | | Millimess 1 μm , $\pm 50 \mu\text{m}$ | 1003 |
| 4333000 | | Millimess 5 μm , $\pm 130 \mu\text{m}$ | 1004 |
| 4337662 | | Digital indicator, 0.0005 mm, 12.5 mm | 1087 BR |
| 4337664 | | Digital indicator, 0.0005 mm, 12.5 mm | 1087 BRi |
| 4473377 | | Setting rings in set for measuring range 4 –9.5 mm | 844 Ke |
| 4473379 | | Setting rings in set for measuring range 10 –20 mm | 844 Ke |
| 4473400 | M6 x 0.75 | Holder for indicator, $\varnothing 8 \text{ mm}$ / M6 x 0.75 | 844 Kg |
| 4473401 | M6 x 0.75 | Holder for indicator, $\varnothing 8 \text{ mm}$ / M6 x 0.75 | 844 Kga |
| 4473402 | M6 x 0.75 | Holder for indicator, $\varnothing .375''$ / M6 x 0.75 | 844 Kgz |
| 4473405 | M6 x 0.75 | Extension for measuring depth, length 50 mm | 844 Kv |
| 4473406 | M6 x 0.75 | Extension for measuring depth, length 100 mm | 844 Kv |
| 4473407 | M6 x 0.75 | Extension for measuring depth, length 250 mm | 844 Kv |
| 4473409 | M6 x 0.75 | Right angle attachment, M6 x 0.75 | 844 Kw |



1004



1003



1002



1087 BR

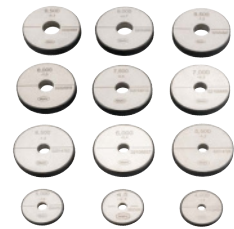

844 Ke



844 Kg;844 Kgz



844 Kga



844 Kv

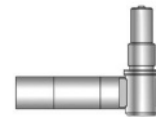

844 Dw;844 Kw

Marameter 844 Kck

Inside measuring probe

FEATURES

- Measuring head made in hardened steel, DLC coated
- Constant measuring force as a result of built-in spring, eliminating user influence
- Extensive modular system is composed of measuring head, transfer needle, holder, depth extension, right angle attachments and setting rings
- Benefits of DLC Coating
 - DLC = Diamond-Like Carbon
 - Extremely high wear resistance, for long service life even on hard or abrasive surfaces
 - Reduction of friction, ideal for sensitive surfaces such as non-ferrous metals and aluminium alloys
 - Wear indicator, worn areas appear as bright spots in the dark DLC coating

The minimum set of a measuring instrument consists of:

- Measuring head, transfer needle and holder plus indicator unit

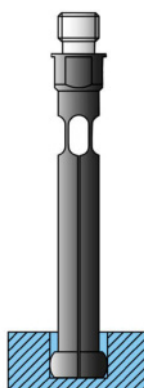

Application:

Standard form with extremely wear resistant DLC-coated surface, ideal also for scratch-sensitive surfaces

- For indicating measurement of diameter and testing for roundness and conicity of bores
- Especially suitable for testing batches
- Determine the reversal point by rocking in the bore

TECHNICAL DATA

| Order no. | Nominal size mm | Type | Measuring range mm | Measuring depth mm | L mm |
|-----------|--------------------|---------|-----------------------|--------------------|---------|
| 4473130 | 1 | 844 Kck | 0.95 – 1.15 | 10.5 | 19.5 |
| 4473131 | 1.1 | 844 Kck | 1.07 – 1.25 | 10.5 | 19.5 |
| 4473132 | 1.2 | 844 Kck | 1.17 – 1.35 | 10.5 | 19.5 |
| 4473133 | 1.3 | 844 Kck | 1.27 – 1.45 | 10.5 | 19.5 |
| 4473134 | 1.4 | 844 Kck | 1.37 – 1.55 | 10.5 | 19.5 |
| 4473135 | 1.75 | 844 Kck | 1.5 – 1.9 | 16 | 25.3 |
| 4473136 | 2 | 844 Kck | 1.8 – 2.2 | 16 | 25.3 |
| 4473137 | 2.25 | 844 Kck | 2.05 – 2.45 | 16 | 25.3 |
| 4473138 | 2.5 | 844 Kck | 2.3 – 2.7 | 21 | 30.6 |
| 4473139 | 2.75 | 844 Kck | 2.55 – 2.95 | 21 | 30.6 |
| 4473140 | 3 | 844 Kck | 2.8 – 3.2 | 21 | 30.6 |
| 4473141 | 3.25 | 844 Kck | 3.05 – 3.45 | 21 | 30.6 |
| 4473142 | 3.5 | 844 Kck | 3.3 – 3.7 | 21 | 30.6 |
| 4473143 | 3.75 | 844 Kck | 3.55 – 3.95 | 21 | 30.6 |
| 4473145 | 4 | 844 Kck | 3.7 – 4.3 | 38 | 47.3 |
| 4473146 | 4.5 | 844 Kck | 4.2 – 4.8 | 38 | 47.3 |
| 4473147 | 5 | 844 Kck | 4.7 – 5.3 | 38 | 47.3 |
| 4473148 | 5.5 | 844 Kck | 5.2 – 5.8 | 38 | 47.3 |
| 4473149 | 6 | 844 Kck | 5.7 – 6.3 | 38 | 47.3 |
| 4473150 | 6.5 | 844 Kck | 6.2 – 6.8 | 38 | 47.3 |
| 4473151 | 7 | 844 Kck | 6.7 – 7.3 | 38 | 47.3 |
| 4473152 | 7.5 | 844 Kck | 7.2 – 7.8 | 38 | 47.3 |
| 4473153 | 8 | 844 Kck | 7.7 – 8.3 | 38 | 47.3 |
| 4473154 | 8.5 | 844 Kck | 8.2 – 8.8 | 45 | 47.3 |
| 4473155 | 9 | 844 Kck | 8.7 – 9.3 | 45 | 47.3 |
| 4473156 | 9.5 | 844 Kck | 9.2 – 9.8 | 45 | 47.3 |
| 4473158 | 10 | 844 Kck | 9.4 – 10.6 | 45 | 48.5 |
| 4473159 | 11 | 844 Kck | 10.4 – 11.6 | 45 | 48.5 |
| 4473160 | 12 | 844 Kck | 11.4 – 12.6 | 45 | 48.5 |
| 4473161 | 13 | 844 Kck | 12.4 – 13.6 | 45 | 48.5 |
| 4473162 | 14 | 844 Kck | 13.4 – 14.6 | 45 | 48.5 |
| 4473163 | 15 | 844 Kck | 14.4 – 15.6 | 45 | 48.5 |
| 4473164 | 16 | 844 Kck | 15.4 – 16.6 | 45 | 48.5 |
| 4473165 | 17 | 844 Kck | 16.4 – 17.6 | 45 | 48.5 |
| 4473166 | 18 | 844 Kck | 17.4 – 18.6 | 45 | 48.5 |
| 4473167 | 19 | 844 Kck | 18.4 – 19.6 | 45 | 48.5 |
| 4473168 | 20 | 844 Kck | 19.4 – 20.6 | 45 | 48.5 |

Marameter 844 KCK

Inside measuring probe

TECHNICAL DATA

| Order no. | Dimension H1 | Dimension L | Connection thread |
|-----------|--------------|-------------|-------------------|
| | mm | mm | |
| 4473130 | 0.6 | 19.5 | M6 x 0.75 |
| 4473131 | 0.6 | 19.5 | M6 x 0.75 |
| 4473132 | 0.6 | 19.5 | M6 x 0.75 |
| 4473133 | 0.6 | 19.5 | M6 x 0.75 |
| 4473134 | 0.6 | 19.5 | M6 x 0.75 |
| 4473135 | 0.9 | 25.3 | M6 x 0.75 |
| 4473136 | 0.9 | 25.3 | M6 x 0.75 |
| 4473137 | 0.9 | 25.3 | M6 x 0.75 |
| 4473138 | 1.2 | 30.6 | M6 x 0.75 |
| 4473139 | 1.2 | 30.6 | M6 x 0.75 |
| 4473140 | 1.2 | 30.6 | M6 x 0.75 |
| 4473141 | 1.2 | 30.6 | M6 x 0.75 |
| 4473142 | 1.2 | 30.6 | M6 x 0.75 |
| 4473143 | 1.2 | 30.6 | M6 x 0.75 |
| 4473145 | 2 | 47.3 | M6 x 0.75 |
| 4473146 | 2 | 47.3 | M6 x 0.75 |
| 4473147 | 2 | 47.3 | M6 x 0.75 |
| 4473148 | 2 | 47.3 | M6 x 0.75 |
| 4473149 | 2 | 47.3 | M6 x 0.75 |
| 4473150 | 2 | 47.3 | M6 x 0.75 |
| 4473151 | 2 | 47.3 | M6 x 0.75 |
| 4473152 | 2 | 47.3 | M6 x 0.75 |
| 4473153 | 2 | 47.3 | M6 x 0.75 |
| 4473154 | 2 | 47.3 | M6 x 0.75 |
| 4473155 | 2 | 47.3 | M6 x 0.75 |
| 4473156 | 2 | 47.3 | M6 x 0.75 |
| 4473158 | 3.3 | 48.5 | M6 x 0.75 |
| 4473159 | 3.3 | 48.5 | M6 x 0.75 |
| 4473160 | 3.3 | 48.5 | M6 x 0.75 |
| 4473161 | 3.3 | 48.5 | M6 x 0.75 |
| 4473162 | 3.3 | 48.5 | M6 x 0.75 |
| 4473163 | 3.3 | 48.5 | M6 x 0.75 |
| 4473164 | 3.3 | 48.5 | M6 x 0.75 |
| 4473165 | 3.3 | 48.5 | M6 x 0.75 |
| 4473166 | 3.3 | 48.5 | M6 x 0.75 |
| 4473167 | 3.3 | 48.5 | M6 x 0.75 |
| 4473168 | 3.3 | 48.5 | M6 x 0.75 |

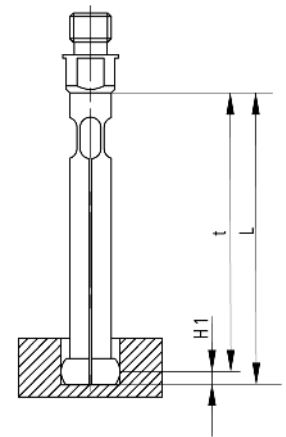

ACCESSORIES

| Order no. | Description |
|-----------|--|
| 4473093 | Transfer pin made of carbide for inside measuring probe 844 K and 844 KC, size 0.95 –1.55 mm |
| 4473094 | Transfer pin made of carbide for inside measuring probe 844 K and 844 KC, size 1.5 –2.45 mm |
| 4473095 | Transfer pin made of carbide for inside measuring probe 844 K and 844 KC, size 2.3 –3.95 mm |
| 4473096 | Transfer pin made of carbide for inside measuring probe 844 K and 844 KC, size 3.7 –9.8 mm |
| 4473097 | Transfer pin made of carbide for inside measuring probe 844 K and 844 KC, size 9.4 –20.6 mm |



Marameter 844 Kk

Inside measuring probe

FEATURES

- Measuring head made of hardened steel, hard chrome plated
- Constant measuring force as a result of built-in spring, eliminating user influence
- Extensive modular system is composed of measuring head, transfer needle, holder, depth extension, right angle attachments and setting rings

The minimum set of a measuring instrument consists of:

- Measuring head, transfer needle and holder plus indicator unit

Application:
Standard model

- For indicating measurement of diameter and testing for roundness and conicity of bores
- Especially suitable for testing batches
- Determine the reversal point by rocking in the bore

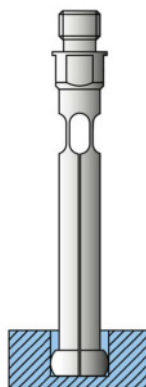

TECHNICAL DATA

| Order no. | Nominal size | Type | Measuring range | Measuring depth | Dimension L |
|-----------|--------------|--------|-----------------|-----------------|-------------|
| | mm | | mm | mm | mm |
| 4473030 | 1 | 844 Kk | 0.95 – 1.15 | 10.5 | 19.5 |
| 4473031 | 1.1 | 844 Kk | 1.07 – 1.25 | 10.5 | 19.5 |
| 4473032 | 1.2 | 844 Kk | 1.17 – 1.35 | 10.5 | 19.5 |
| 4473033 | 1.3 | 844 Kk | 1.27 – 1.45 | 10.5 | 19.5 |
| 4473034 | 1.4 | 844 Kk | 1.37 – 1.55 | 10.5 | 19.5 |
| 4473035 | 1.75 | 844 Kk | 1.5 – 1.9 | 16 | 25.3 |
| 4473036 | 2 | 844 Kk | 1.8 – 2.2 | 16 | 25.3 |
| 4473037 | 2.25 | 844 Kk | 2.05 – 2.45 | 16 | 25.3 |
| 4473038 | 2.5 | 844 Kk | 2.3 – 2.7 | 21 | 30.6 |
| 4473039 | 2.75 | 844 Kk | 2.55 – 2.95 | 21 | 30.6 |
| 4473040 | 3 | 844 Kk | 2.8 – 3.2 | 21 | 30.6 |
| 4473041 | 3.25 | 844 Kk | 3.05 – 3.45 | 21 | 30.6 |
| 4473042 | 3.5 | 844 Kk | 3.3 – 3.7 | 21 | 30.6 |
| 4473043 | 3.75 | 844 Kk | 3.55 – 3.95 | 21 | 30.6 |
| 4473045 | 4 | 844 Kk | 3.7 – 4.3 | 38 | 47.3 |
| 4473046 | 4.5 | 844 Kk | 4.2 – 4.8 | 38 | 47.3 |
| 4473047 | 5 | 844 Kk | 4.7 – 5.3 | 38 | 47.3 |
| 4473048 | 5.5 | 844 Kk | 5.2 – 5.8 | 38 | 47.3 |
| 4473049 | 6 | 844 Kk | 5.7 – 6.3 | 38 | 47.3 |
| 4473050 | 6.5 | 844 Kk | 6.2 – 6.8 | 38 | 47.3 |
| 4473051 | 7 | 844 Kk | 6.7 – 7.3 | 38 | 47.3 |
| 4473052 | 7.5 | 844 Kk | 7.2 – 7.8 | 38 | 47.3 |
| 4473053 | 8 | 844 Kk | 7.7 – 8.3 | 38 | 47.3 |
| 4473054 | 8.5 | 844 Kk | 8.2 – 8.8 | 45 | 47.3 |
| 4473055 | 9 | 844 Kk | 8.7 – 9.3 | 45 | 47.3 |
| 4473056 | 9.5 | 844 Kk | 9.2 – 9.8 | 45 | 47.3 |
| 4473058 | 10 | 844 Kk | 9.4 – 10.6 | 45 | 48.5 |
| 4473059 | 11 | 844 Kk | 10.4 – 11.6 | 45 | 48.5 |
| 4473060 | 12 | 844 Kk | 11.4 – 12.6 | 45 | 48.5 |
| 4473061 | 13 | 844 Kk | 12.4 – 13.6 | 45 | 48.5 |
| 4473062 | 14 | 844 Kk | 13.4 – 14.6 | 45 | 48.5 |
| 4473063 | 15 | 844 Kk | 14.4 – 15.6 | 45 | 48.5 |
| 4473064 | 16 | 844 Kk | 15.4 – 16.6 | 45 | 48.5 |
| 4473065 | 17 | 844 Kk | 16.4 – 17.6 | 45 | 48.5 |
| 4473066 | 18 | 844 Kk | 17.4 – 18.6 | 45 | 48.5 |
| 4473067 | 19 | 844 Kk | 18.4 – 19.6 | 45 | 48.5 |
| 4473068 | 20 | 844 Kk | 19.4 – 20.6 | 45 | 48.5 |

Marameter 844 Kk

Inside measuring probe

TECHNICAL DATA

| Order no. | H1 | L | Connection thread |
|-----------|-----|------|-------------------|
| | mm | mm | |
| 4473030 | 0.6 | 19.5 | M6 x 0.75 |
| 4473031 | 0.6 | 19.5 | M6 x 0.75 |
| 4473032 | 0.6 | 19.5 | M6 x 0.75 |
| 4473033 | 0.6 | 19.5 | M6 x 0.75 |
| 4473034 | 0.6 | 19.5 | M6 x 0.75 |
| 4473035 | 0.9 | 25.3 | M6 x 0.75 |
| 4473036 | 0.9 | 25.3 | M6 x 0.75 |
| 4473037 | 0.9 | 25.3 | M6 x 0.75 |
| 4473038 | 1.2 | 30.6 | M6 x 0.75 |
| 4473039 | 1.2 | 30.6 | M6 x 0.75 |
| 4473040 | 1.2 | 30.6 | M6 x 0.75 |
| 4473041 | 1.2 | 30.6 | M6 x 0.75 |
| 4473042 | 1.2 | 30.6 | M6 x 0.75 |
| 4473043 | 1.2 | 30.6 | M6 x 0.75 |
| 4473045 | 2 | 47.3 | M6 x 0.75 |
| 4473046 | 2 | 47.3 | M6 x 0.75 |
| 4473047 | 2 | 47.3 | M6 x 0.75 |
| 4473048 | 2 | 47.3 | M6 x 0.75 |
| 4473049 | 2 | 47.3 | M6 x 0.75 |
| 4473050 | 2 | 47.3 | M6 x 0.75 |
| 4473051 | 2 | 47.3 | M6 x 0.75 |
| 4473052 | 2 | 47.3 | M6 x 0.75 |
| 4473053 | 2 | 47.3 | M6 x 0.75 |
| 4473054 | 2 | 47.3 | M6 x 0.75 |
| 4473055 | 2 | 47.3 | M6 x 0.75 |
| 4473056 | 2 | 47.3 | M6 x 0.75 |
| 4473058 | 3.3 | 48.5 | M6 x 0.75 |
| 4473059 | 3.3 | 48.5 | M6 x 0.75 |
| 4473060 | 3.3 | 48.5 | M6 x 0.75 |
| 4473061 | 3.3 | 48.5 | M6 x 0.75 |
| 4473062 | 3.3 | 48.5 | M6 x 0.75 |
| 4473063 | 3.3 | 48.5 | M6 x 0.75 |
| 4473064 | 3.3 | 48.5 | M6 x 0.75 |
| 4473065 | 3.3 | 48.5 | M6 x 0.75 |
| 4473066 | 3.3 | 48.5 | M6 x 0.75 |
| 4473067 | 3.3 | 48.5 | M6 x 0.75 |
| 4473068 | 3.3 | 48.5 | M6 x 0.75 |

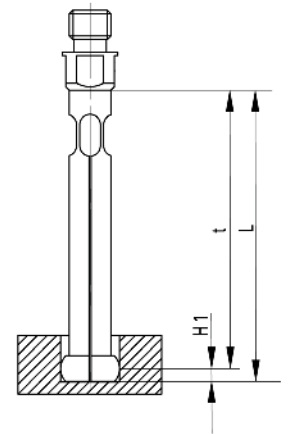

ACCESSORIES

| Order no. | Description |
|-----------|--|
| 4473093 | Transfer pin made of carbide for inside measuring probe 844 K and 844 KC, size 0.95 –1.55 mm |
| 4473094 | Transfer pin made of carbide for inside measuring probe 844 K and 844 KC, size 1.5 –2.45 mm |
| 4473095 | Transfer pin made of carbide for inside measuring probe 844 K and 844 KC, size 2.3 –3.95 mm |
| 4473096 | Transfer pin made of carbide for inside measuring probe 844 K and 844 KC, size 3.7 –9.8 mm |
| 4473097 | Transfer pin made of carbide for inside measuring probe 844 K and 844 KC, size 9.4 –20.6 mm |



Marameter 844 KSk

Blind hole measuring probe

FEATURES

- Measuring head made of hardened steel, hard chrome plated
- Constant measuring force as a result of built-in spring, eliminating user influence
- Extensive modular system is composed of measuring head, transfer needle, holder, depth extension, right angle attachments and setting rings

The minimum set of a measuring instrument consists of:

- Measuring head, transfer needle and holder plus indicator unit

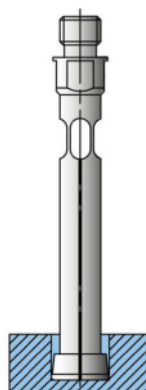

Application:
Model for blind holes

- For measurements near to the bottom of bores
- For indicating measurement of diameter and testing for roundness and conicity of bores
- Especially suitable for testing batches
- Determine the reversal point by rocking in the bore

TECHNICAL DATA

| Order no. | Nominal size | Type | Measuring range | Measuring depth | Dimension L |
|-----------|--------------|---------|-----------------|-----------------|-------------|
| | mm | | mm | mm | mm |
| 4473245 | 4 | 844 KSk | 3.7 – 4.3 | 38 | 47.3 |
| 4473246 | 4.5 | 844 KSk | 4.2 – 4.8 | 38 | 47.3 |
| 4473247 | 5 | 844 KSk | 4.7 – 5.3 | 38 | 47.3 |
| 4473248 | 5.5 | 844 KSk | 5.2 – 5.8 | 38 | 47.3 |
| 4473249 | 6 | 844 KSk | 5.7 – 6.3 | 38 | 47.3 |
| 4473250 | 6.5 | 844 KSk | 6.2 – 6.8 | 38 | 47.3 |
| 4473251 | 7 | 844 KSk | 6.7 – 7.3 | 38 | 47.3 |
| 4473252 | 7.5 | 844 KSk | 7.2 – 7.8 | 38 | 47.3 |
| 4473253 | 8 | 844 KSk | 7.7 – 8.3 | 38 | 47.3 |
| 4473254 | 8.5 | 844 KSk | 8.2 – 8.8 | 45 | 47.3 |
| 4473255 | 9 | 844 KSk | 8.7 – 9.3 | 45 | 47.3 |
| 4473256 | 9.5 | 844 KSk | 9.2 – 9.8 | 45 | 47.3 |
| 4473258 | 10 | 844 KSk | 9.4 – 10.6 | 45 | 48.5 |
| 4473259 | 11 | 844 KSk | 10.4 – 11.6 | 45 | 48.5 |
| 4473260 | 12 | 844 KSk | 11.4 – 12.6 | 45 | 48.5 |
| 4473261 | 13 | 844 KSk | 12.4 – 13.6 | 45 | 48.5 |
| 4473262 | 14 | 844 KSk | 13.4 – 14.6 | 45 | 48.5 |
| 4473263 | 15 | 844 KSk | 14.4 – 15.6 | 45 | 48.5 |
| 4473264 | 16 | 844 KSk | 15.4 – 16.6 | 45 | 48.5 |
| 4473265 | 17 | 844 KSk | 16.4 – 17.6 | 45 | 48.5 |
| 4473266 | 18 | 844 KSk | 17.4 – 18.6 | 45 | 48.5 |
| 4473267 | 19 | 844 KSk | 18.4 – 19.6 | 45 | 48.5 |
| 4473268 | 20 | 844 KSk | 19.4 – 20.6 | 45 | 48.5 |

Marameter 844 KSk

Blind hole measuring probe

TECHNICAL DATA

| Order no. | H2 | Dimension L | Connection thread |
|-----------|-----|-------------|-------------------|
| | mm | mm | |
| 4473245 | 0.5 | 47.3 | M6 x 0.75 |
| 4473246 | 0.5 | 47.3 | M6 x 0.75 |
| 4473247 | 0.5 | 47.3 | M6 x 0.75 |
| 4473248 | 0.5 | 47.3 | M6 x 0.75 |
| 4473249 | 0.5 | 47.3 | M6 x 0.75 |
| 4473250 | 0.5 | 47.3 | M6 x 0.75 |
| 4473251 | 0.5 | 47.3 | M6 x 0.75 |
| 4473252 | 0.5 | 47.3 | M6 x 0.75 |
| 4473253 | 0.5 | 47.3 | M6 x 0.75 |
| 4473254 | 0.5 | 47.3 | M6 x 0.75 |
| 4473255 | 0.5 | 47.3 | M6 x 0.75 |
| 4473256 | 0.5 | 47.3 | M6 x 0.75 |
| 4473258 | 1 | 48.5 | M6 x 0.75 |
| 4473259 | 1 | 48.5 | M6 x 0.75 |
| 4473260 | 1 | 48.5 | M6 x 0.75 |
| 4473261 | 1 | 48.5 | M6 x 0.75 |
| 4473262 | 1 | 48.5 | M6 x 0.75 |
| 4473263 | 1 | 48.5 | M6 x 0.75 |
| 4473264 | 1 | 48.5 | M6 x 0.75 |
| 4473265 | 1 | 48.5 | M6 x 0.75 |
| 4473266 | 1 | 48.5 | M6 x 0.75 |
| 4473267 | 1 | 48.5 | M6 x 0.75 |
| 4473268 | 1 | 48.5 | M6 x 0.75 |

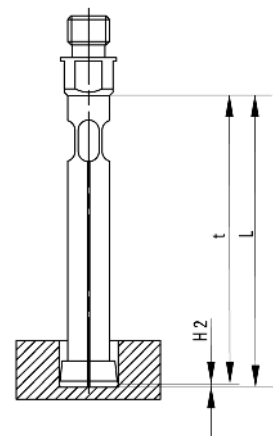

ACCESSORIES

| Order no. | Description |
|-----------|---|
| 4473296 | Transfer pin made of carbide for inside measuring probe 844 KS, size 3.7 –9.8 mm |
| 4473297 | Transfer pin made of carbide for inside measuring probe 844 KS, size 9.4 –20.6 mm |



Marameter | Modular system

By combining with a wide range of accessories (indicators, internal probes with drive needles, holders, extensions and right angle attachment), the internal gage becomes a precision measuring instrument, adapted to the measuring task.

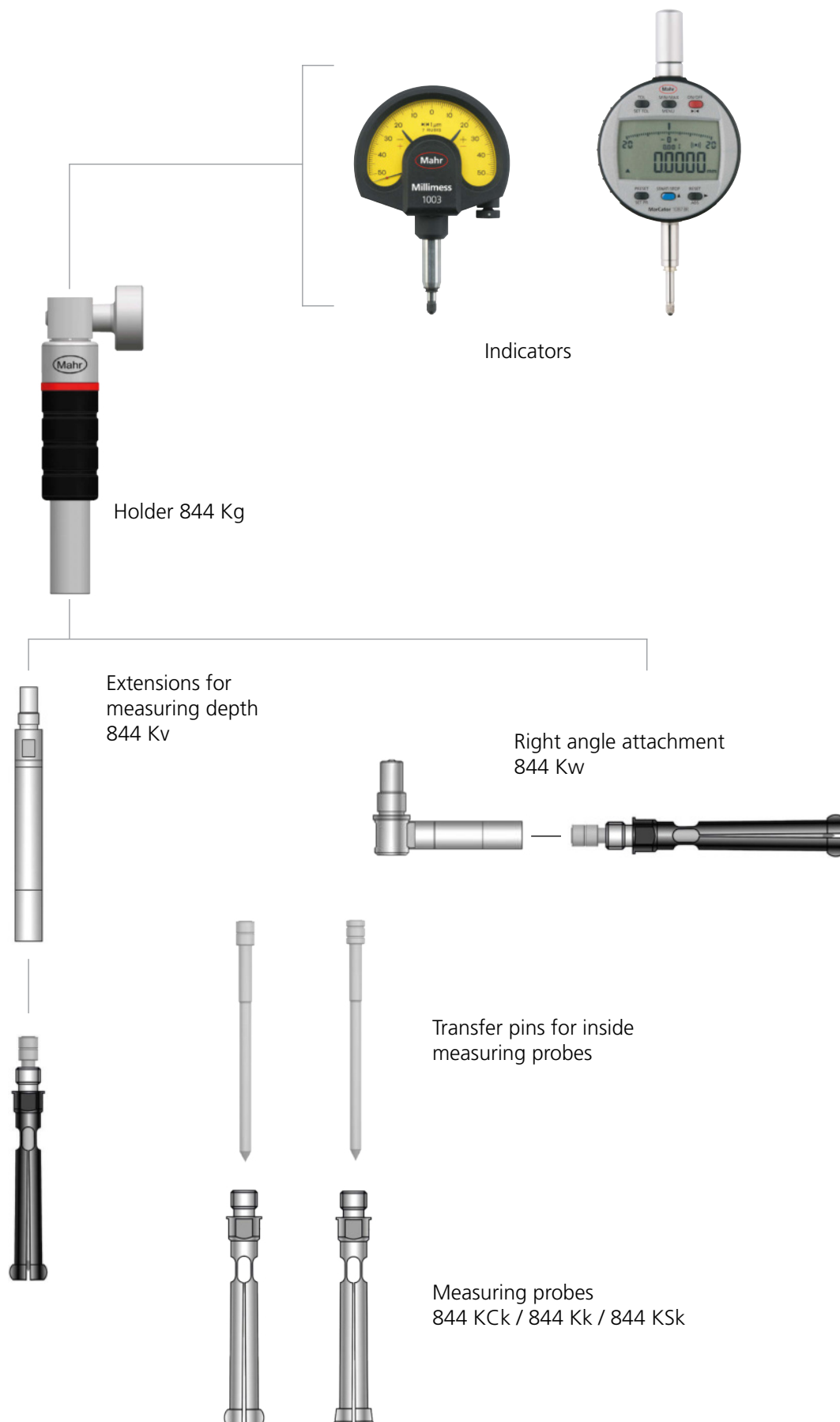

Marameter 844 Kg / 844 Kga / 844 Kgz

Holder for indicator

FEATURES

- Holder for mounting an indicator (comparator, dial gage or inductive probe) and connection of an 844 K/KC/KS inside measuring probe or corresponding accessories such as 844 Kt measuring depth extensions or 844 Kw right angle attachment



Applications:

- **844 Kga:** Special design with retracting button, for easier insertion of the internal measuring probe into bores. Recommended for small and sensitive bores.
- **844 Kgz:** Special design for dial gages with shaft diameter 3/8 inch (typical for dial gages from USA).

TECHNICAL DATA

| Order no. | Type | Mount diameter | Dimension L | d1 | l | Connection thread |
|-----------|---------|----------------|-------------|----|----|-------------------|
| 4473400 | 844 Kg | 8 mm | 73 | 10 | 23 | M6 x 0.75 |
| 4473401 | 844 Kga | 8 mm | 73 | 10 | 23 | M6 x 0.75 |
| 4473402 | 844 Kgz | .375" | 73 | 10 | 23 | M6 x 0.75 |

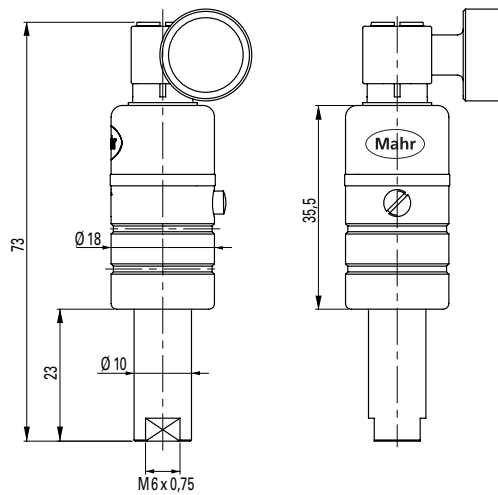

Marameter 844 Kv

Extension for measuring depth

FEATURES

- The measuring depth extension is screwed in between the holder (844 Kg/Kga) and the inside probe (844 K/KS/KS)



Application:

- To reach measuring points in deep bores

TECHNICAL DATA

| Order no. | Type | Dimension L |
|-----------|--------|-------------|
| | | mm |
| 4473405 | 844 Kv | 50 |
| 4473406 | 844 Kv | 100 |
| 4473407 | 844 Kv | 250 |

| Order no. | Dimension L | d | Connection thread |
|-----------|-------------|-----|-------------------|
| | mm | mm | |
| 4473405 | 50 | 7.9 | M6 x 0.75 |
| 4473406 | 100 | 7.9 | M6 x 0.75 |
| 4473407 | 250 | 7.9 | M6 x 0.75 |

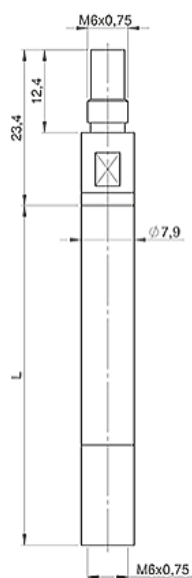

Marameter 844 Kt

Depth stop

FEATURES

Application:

- For setting the 844 K/KC/KS split ball gages to a defined and repeatable measuring depth
- Clamping on the cylindrical shaft $\varnothing 7.9$ mm of the measuring depth extensions 844 Kv

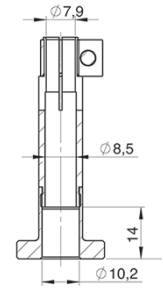
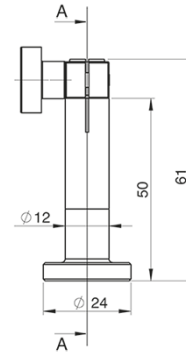
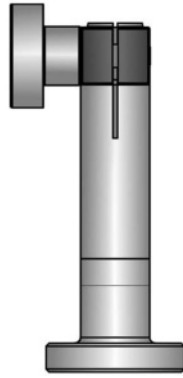

SCHNITT A-A

TECHNICAL DATA

| Order no. | Type | Size of measuring surface | Mount diameter |
|-----------|--------|---------------------------|--------------------------------------|
| 4473408 | 844 Kt | $\varnothing 24$ mm | mm For shaft $\varnothing 7.9$ mm |

Marameter 844 Kw

Right angle attachment

FEATURES

- The 844 Kw right angle attachment is screwed in between holder 844 Kg and bore gage 844 K / 844 KC / 844 KS (if necessary extensions 844 Kv)

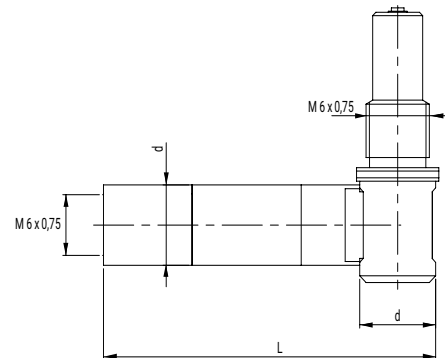
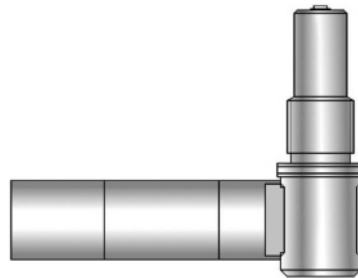

Application:

- For space-saving and side-entering measurement of bores
- Typical measuring problem situations:
 - Narrow conditions in turning and grinding machines
 - Side outgoing bores or bearing points in housings

TECHNICAL DATA

| Order no. | Type | L | d | Connection thread |
|-----------|--------|----------|-----------|-------------------|
| 4473409 | 844 Kw | mm 29 | mm 7.9 | M6 x 0.75 |

Marameter 844 Ke

Setting rings in set

FEATURES

2 Designs:

- Setting rings \varnothing 1.0 – 2.75 mm made of hardened steel according to factory standard: manufacturing tolerance of the bore: $\pm 1 \mu\text{m}$
- Setting rings \varnothing 3 – 20 mm made of hardened steel according to DIN 2250 form C

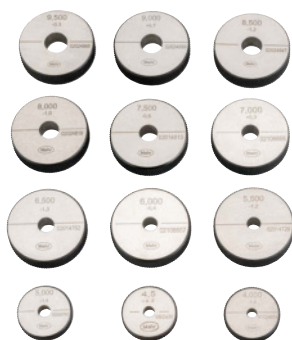

Application:

- The setting rings are used as dimensional standards for adjusting the bore gages 844 K/KC/KS to the respective nominal dimension

TECHNICAL DATA

| Order no. | Number of setting rings | Type | Nominal size | Model |
|-----------|-------------------------|--------|--|----------------|
| | | | mm | |
| 4473375 | 5 | 844 Ke | 1 1.1 1.2 1.3 1.4 | Hardened steel |
| 4473376 | 9 | 844 Ke | 1.75 2 2.25 2.5 2.75 3 3.25 3.5 3.75 | Hardened steel |
| 4473377 | 12 | 844 Ke | 4 4.5 5 5.5 6 6.5 7 7.5 8 8.5 9 9.5 | Hardened steel |
| 4473378 | 21 | 844 Ke | 1.75 2 2.25 2.5 2.75 3 3.25 3.5 3.75 4 4.5 5 5.5 6 6.5 7 7.5 8 8.5 9 9.5 | Hardened steel |
| 4473379 | 11 | 844 Ke | 10 11 12 13 14 15 16 17 18 19 20 | Hardened steel |

Marameter 844 Ke

Setting rings in set

ACCESSORIES

| Order no. | Description | Type |
|-----------|---------------------------------|--------|
| 4473310 | Setting ring, Ø 1 mm | 844 Ke |
| 4473311 | Setting ring, Ø 1.1 mm | 844 Ke |
| 4473312 | Setting ring, Ø 1.2 mm | 844 Ke |
| 4473313 | Setting ring, Ø 1.3 mm | 844 Ke |
| 4473314 | Setting ring, Ø 1.4 mm | 844 Ke |
| 4473315 | Setting ring, Ø 1.75 mm | 844 Ke |
| 4473316 | Setting ring, Ø 2 mm | 844 Ke |
| 4473317 | Setting ring, Ø 2.25 mm | 844 Ke |
| 4473318 | Setting ring, Ø 2.5 mm | 844 Ke |
| 4473319 | Setting ring, Ø 2.75 mm | 844 Ke |
| 4710014 | Ring gage DIN 2250 C, Ø 3 mm | 355 E |
| 4710015 | Ring gage DIN 2250 C, Ø 3.25 mm | 355 E |
| 4710016 | Ring gage DIN 2250 C, Ø 3.5 mm | 355 E |
| 4710017 | Ring gage DIN 2250 C, Ø 3.75 mm | 355 E |
| 4710018 | Ring gage DIN 2250 C, Ø 4 mm | 355 E |
| 4710019 | Ring gage DIN 2250 C, Ø 4.5 mm | 355 E |
| 4710020 | Ring gage DIN 2250 C, Ø 5 mm | 355 E |
| 4710021 | Ring gage DIN 2250 C, Ø 5.5 mm | 355 E |
| 4710022 | Ring gage DIN 2250 C, Ø 6 mm | 355 E |
| 4710023 | Ring gage DIN 2250 C, Ø 6.5 mm | 355 E |
| 4710024 | Ring gage DIN 2250 C, Ø 7 mm | 355 E |
| 4710025 | Ring gage DIN 2250 C, Ø 7.5 mm | 355 E |
| 4710026 | Ring gage DIN 2250 C, Ø 8 mm | 355 E |
| 4710027 | Ring gage DIN 2250 C, Ø 8.5 mm | 355 E |
| 4710028 | Ring gage DIN 2250 C, Ø 9 mm | 355 E |
| 4710029 | Ring gage DIN 2250 C, Ø 9.5 mm | 355 E |
| 4710030 | Ring gage DIN 2250 C, Ø 10 mm | 355 E |
| 4710031 | Ring gage DIN 2250 C, Ø 11 mm | 355 E |
| 4710032 | Ring gage DIN 2250 C, Ø 12 mm | 355 E |
| 4710033 | Ring gage DIN 2250 C, Ø 13 mm | 355 E |
| 4710034 | Ring gage DIN 2250 C, Ø 14 mm | 355 E |
| 4710035 | Ring gage DIN 2250 C, Ø 15 mm | 355 E |
| 4710036 | Ring gage DIN 2250 C, Ø 16 mm | 355 E |
| 4710037 | Ring gage DIN 2250 C, Ø 17 mm | 355 E |
| 4710038 | Ring gage DIN 2250 C, Ø 18 mm | 355 E |
| 4710039 | Ring gage DIN 2250 C, Ø 19 mm | 355 E |
| 4710040 | Ring gage DIN 2250 C, Ø 20 mm | 355 E |



844 Ke



355 E

Marameter 844 KM

Measuring stand

FEATURES

- High measuring column with large adjustment range
- Stop ring for measuring height, ideal when changing probes
- Large stroke for probe lowering
- Depth stop for stroke limitation
- Large measuring table (Ø 120 mm) with dust grooves and 4 threaded holes for the individual mounting of a prismatic stop 844 KMp
- Adjustment element for device holder 844 Kg / 844 Kga / 844 Kgz with shaft Ø 10 mm
- Additional mounting Ø 8 mm for optional dial gage as measuring depth indicator

Application:

- Ideal for production testing with 844 KM inside measuring probes, eliminates need for rocking to find reversal point



TECHNICAL DATA

| Order no. | Type |
|-----------|--------|
| 4473420 | 844 KM |

ACCESSORIES

| Order no. | Description | Type |
|-----------|--|---------|
| 4473425 | Floating holder for measuring stand 844 KM, including. 2 bushings to clamp shaft Ø 10 mm and Ø 11.9 mm | 844 KMs |
| 4473426 | Prismatic stop including knurled clamping screw for measuring table 844 KM | 844 KMp |



844 KMs

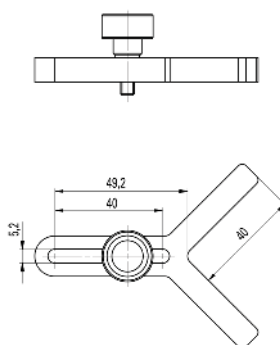

844 KMp

Marameter 844 NB

Self-centering dial bore gage

FEATURES

- Measuring head consists of a carbide tipped moving anvil and an interchangeable stationary anvil with a carbide ball
- Transmission lever system transfers movement of movable anvil to indicating instrument
- The broad centering bridge ensures automatic centering in the bore
- Resistant to temperature because the shank and transfer rod are made of heat resistant Invar steel
- Highly resistant to wear and tear because of carbide tipped moving anvil
- Constant measuring force due to built-in spring, eliminating user influence
- Universally applicable and extremely versatile
 - Each instrument spans a broad measuring range
 - Quick and easy to adjust to any size (within its range)
- Invar steel has a particularly low expansion coefficient
 - Instrument totally insensitive to any kind of heat (including user body heat and increased ambient temperature)
- **Package contains:** measuring holder, measuring head, anvil spindle, wooden case, excludes indicator

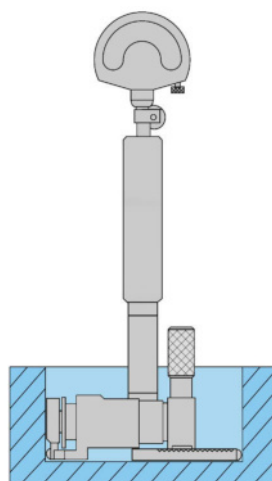

Application:

- For blind holes, to measure almost to the base of a bore

TECHNICAL DATA

| Order no. | | 4474179 | 4474180 | 4474186 |
|---------------------|---------------|-----------|-----------|---------------|
| Type | | | 844 NB | |
| Measuring range | mm | 20 – 50 | 50 – 110 | 110 – 300 |
| Measuring range | inch | 0.79 – 2" | 2 – 4.33" | 4.33 – 11.81" |
| Error limit G_e | μm | 4 | 3 | 2.5 |
| Repeatability f_w | μm | | 1 | |

| Order no. | a | b | c | d | e |
|-----------|-----|----|----|----|-----|
| | mm | mm | mm | mm | mm |
| 4474179 | 1.5 | 10 | 77 | 60 | 163 |
| 4474180 | 1.5 | 12 | 60 | 60 | 144 |
| 4474186 | 2 | 18 | 90 | 90 | 163 |

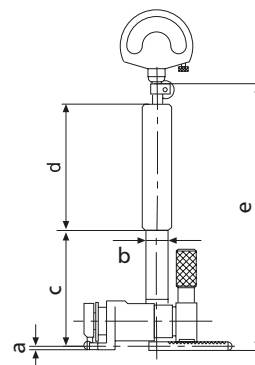

ACCESSORIES

| Order no. | Description | Type |
|-----------|--|----------|
| 4333000 | Millimess 5 μm , \pm 130 μm | 1004 |
| 4334000 | Millimess 1 μm , \pm 50 μm | 1003 |
| 4335000 | Millimess 0.5 μm , \pm 25 μm | 1002 |
| 4337662 | Digital indicator, 0.0005 mm, 12.5 mm | 1087 BR |
| 4337664 | Digital indicator, 0.0005 mm, 12.5 mm | 1087 BRi |



1004



1003



1002



1087 BR

Marameter 844 N

Self-centering dial bore gage

FEATURES

- Measuring head consists of a carbide tipped moving anvil and an interchangeable stationary anvil with a hardened steel ball
- Transmission lever system transfers movement of movable anvil to indicating instrument
- The broad centering bridge ensures automatic centering in the bore
- Resistant to temperature because the shank and transfer rod are made of heat resistant Invar steel
- Highly resistant to wear and tear because of carbide tipped moving anvil
- Constant measuring force due to built-in spring, eliminating user influence
- Universally applicable and extremely versatile
 - Each instrument spans a broad measuring range
 - Quick and easy to adjust to any size (within its range)
- Extensive modular system is composed of measuring head, holder, extensions, right angle attachments and depth stops
- Invar steel has a particularly low expansion coefficient
 - Instrument totally insensitive to any kind of heat (including user body heat and increased ambient temperature)
- **Package contains:** measuring holder, measuring head, anvil spindle, wooden case, excludes indicator



Application

- Measuring the diameter, roundness and conical form of a bore as well as the distances of parallel plane surfaces

TECHNICAL DATA

| Order no. | Type | Measuring range | Measuring range | Distance of movable anvil | Measuring depth | Error limit G_c | Repeatability f_w |
|-----------|-------|-----------------|-----------------|---------------------------|-----------------|-------------------|---------------------|
| | | mm | inch | mm | mm | μm | μm |
| 4474000 | 844 N | 18–50 | .7–2" | 1.3 | 115 | 2 | 0.5 |
| 4474001 | 844 N | 35–100 | 1.4–4" | 1.3 | 148 | 2 | 0.5 |
| 4474002 | 844 N | 100–250 | 4–10" | 1.6 | 230 | 2 | 0.5 |
| 4474003 | 844 N | 250–400 | 10–16" | 2.6 | 366 | 3 | 1.5 |
| 4474004 | 844 N | 400–800 | 16–32" | 2.6 | 366 | 3 | 1.5 |
| 4474005 | 844 N | 250–800 | 10–32" | 2.6 | 366 | 3 | 1.5 |

| Order no. | a | b | c | d | e |
|-----------|------|----|-----|-----|----|
| | mm | mm | mm | mm | mm |
| 4474000 | 5.3 | 8 | 115 | 63 | 22 |
| 4474001 | 8.5 | 12 | 148 | 80 | 22 |
| 4474002 | 11.5 | 18 | 230 | 100 | 25 |
| 4474003 | 16 | 24 | 366 | 110 | 28 |
| 4474004 | 17.5 | 24 | 366 | 110 | 28 |
| 4474005 | 17.5 | 24 | 366 | 110 | 28 |

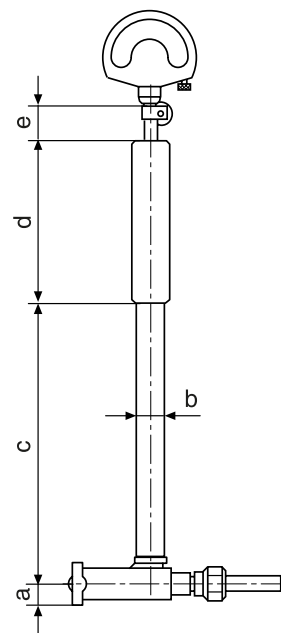

Marameter 844 N

Self-centering dial bore gage

ACCESSORIES

| Order no. | Description | Type |
|-----------|---|----------|
| 4335000 | Millimess 0.5 μm , $\pm 25 \mu\text{m}$ | 1002 |
| 4334000 | Millimess 1 μm , $\pm 50 \mu\text{m}$ | 1003 |
| 4333000 | Millimess 5 μm , $\pm 130 \mu\text{m}$ | 1004 |
| 4337662 | Digital indicator, 0.0005 mm, 12.5 mm | 1087 BR |
| 4337664 | Digital indicator, 0.0005 mm, 12.5 mm | 1087 BRi |
| 4800120 | Holder, span width 0 –70 mm | 420 h |
| 4800121 | Holder, span width 0 –120 mm | 420 h |
| 4800122 | Holder, span width 100 –220 mm | 420 h |
| 4800123 | Holder, span width 100 –420 mm | 420 h |
| 4800124 | Holder, span width 400 –820 mm | 420 h |
| 4474080 | Adjustment bridge (70 x 12 mm), for measuring range 18 –250 mm (for 844 N) | 844 Neb |
| 4474081 | Adjustment bridge (165 x 17 mm), for measuring range 18 –400 mm (for 844 N) | 844 Neb |
| 4474082 | Adjustment bridge (320 x 20 mm), for measuring range 18 –800 mm (for 844 N) | 844 Neb |
| 4474050 | Short holder (18 –50 mm) | 844 Ngk |
| 4474051 | Short holder (35 –100 mm) | 844 Ngk |
| 4474052 | Short holder (100 –250 mm) | 844 Ngk |
| 4474053 | Short holder (250 –800 mm) | 844 Ngk |
| 4474060 | Measuring depth extension (250 mm) for measuring range 35 –100 mm | 844 Nv |
| 4474061 | Measuring depth extension (250 mm) for measuring range 100 –250 mm | 844 Nv |
| 4474062 | Measuring depth extension (500 mm) for measuring range 100 –250 mm | 844 Nv |
| 4474063 | Measuring depth extension (250 mm) for measuring range 250 –800 mm | 844 Nv |
| 4474064 | Measuring depth extension (500 mm) for measuring range 250 –800 mm | 844 Nv |
| 4474066 | Measuring depth extension (250 mm) for measuring range 18 –50 mm | 844 Nv |
| 4474070 | Right angle attachment, bore depth 45 mm, for measuring range 18 –50 mm | 844 Nw |
| 4474071 | Right angle attachment, bore depth 55 mm, for measuring range 35 –100 mm | 844 Nw |
| 4474072 | Right angle attachment, bore depth 70 mm, for measuring range 100 –250 mm | 844 Nw |
| 4470098 | Base for mounting holder 420 h up to 420 mm | 844 ef |
| 4470095 | Measuring jaw (60 x 9.5 x 9 mm), for measuring range 18 –800 mm (for 844 N) | 844 em |



1004



1003



1002



1087 BR



844 em



844 Neb



844 ef

Marameter 844 NH

Self-centering dial bore gage

FEATURES

- Measuring head consists of a carbide-tipped, movable measuring pin and an opposing interchangeable stationary counter probe with carbide ball
- Movements of the measuring pin are transmitted to the indicating instrument via the ring segment
- The broad centering bridge ensures automatic centering in the bore
- Insensitive to temperature due to both the shaft and the transfer rod being made from Invar steel
- Carbide tipped measuring contacts for high wear resistance
- Constant measuring force due to built-in spring, eliminating user influence
- Universally applicable and extremely versatile
 - Each instrument spans a broad measuring range
 - Quick and easy to adjust to any size (within its range)
- Measuring head, measuring instrument holder, depth extensions, right angle attachments, and depth stops form a comprehensive modular system
- Invar steel makes the inner measuring device insensitive to temperature influences of any kind. Body heat from the user or a rise in ambient temperature in the workplace have virtually no influence on measuring results
- **Package contains:** measuring holder, measuring head, anvil spindle, wooden case, excludes indicator



Application:

- Measuring the diameter, roundness and conical form of a bore as well as the distances of parallel plane surfaces

TECHNICAL DATA

| Order no. | Type | Measuring range | | Distance of movable anvil | Measuring depth | Error limit G_v | Repeatability f_w |
|-----------|--------|-----------------|----------|---------------------------|-----------------|-------------------|---------------------|
| | | mm | inch | | | | |
| 4475000 | 844 NH | 18 – 50 | .7 – 2" | 1.3 | 115 | 2 | 0.5 |
| 4475001 | 844 NH | 35 – 100 | 1.4 – 4" | 1.3 | 148 | 2 | 0.5 |
| 4475002 | 844 NH | 100 – 250 | 4 – 10" | 1.6 | 230 | 2 | 0.5 |
| 4475003 | 844 NH | 250 – 400 | 10 – 16" | 2.6 | 336 | 3 | 1.5 |
| 4475004 | 844 NH | 400 – 800 | 16 – 32" | 2.6 | 336 | 3 | 1.5 |
| 4475005 | 844 NH | 250 – 800 | 10 – 32" | 2.6 | 336 | 3 | 1.5 |

| Order no. | a | b | c | d | e |
|-----------|------|----|-----|-----|----|
| | mm | mm | mm | mm | mm |
| 4475000 | 5.3 | 8 | 115 | 63 | 22 |
| 4475001 | 8.5 | 12 | 148 | 80 | 22 |
| 4475002 | 11.5 | 18 | 230 | 100 | 25 |
| 4475003 | 16 | 24 | 366 | 110 | 28 |
| 4475004 | 17.5 | 24 | 366 | 110 | 28 |
| 4475005 | 17.5 | 24 | 366 | 110 | 28 |

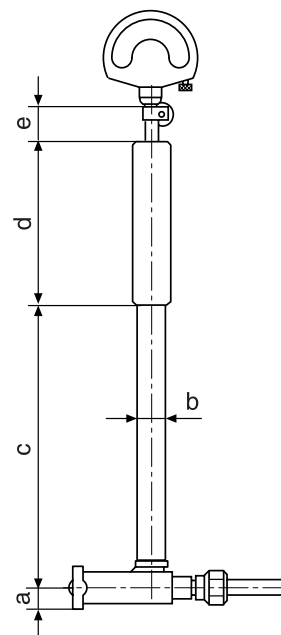

Marameter 844 NH

Self-centering dial bore gage

ACCESSORIES

| Order no. | Description | Type |
|-----------|---|----------|
| 4335000 | Millimess 0.5 μm , $\pm 25 \mu\text{m}$ | 1002 |
| 4334000 | Millimess 1 μm , $\pm 50 \mu\text{m}$ | 1003 |
| 4333000 | Millimess 5 μm , $\pm 130 \mu\text{m}$ | 1004 |
| 4337662 | Digital indicator, 0.0005 mm, 12.5 mm | 1087 BR |
| 4337664 | Digital indicator, 0.0005 mm, 12.5 mm | 1087 BRi |
| 4800120 | Holder, span width 0 –70 mm | 420 h |
| 4800121 | Holder, span width 0 –120 mm | 420 h |
| 4800122 | Holder, span width 100 –220 mm | 420 h |
| 4800123 | Holder, span width 100 –420 mm | 420 h |
| 4800124 | Holder, span width 400 –820 mm | 420 h |
| 4474080 | Adjustment bridge (70 x 12 mm), for measuring range 18 –250 mm (for 844 N) | 844 Neb |
| 4474081 | Adjustment bridge (165 x 17 mm), for measuring range 18 –400 mm (for 844 N) | 844 Neb |
| 4474082 | Adjustment bridge (320 x 20 mm), for measuring range 18 –800 mm (for 844 N) | 844 Neb |
| 4474050 | Short holder (18 –50 mm) | 844 Ngk |
| 4474051 | Short holder (35 –100 mm) | 844 Ngk |
| 4474052 | Short holder (100 –250 mm) | 844 Ngk |
| 4474053 | Short holder (250 –800 mm) | 844 Ngk |
| 4474060 | Measuring depth extension (250 mm) for measuring range 35 –100 mm | 844 Nv |
| 4474061 | Measuring depth extension (250 mm) for measuring range 100 –250 mm | 844 Nv |
| 4474062 | Measuring depth extension (500 mm) for measuring range 100 –250 mm | 844 Nv |
| 4474063 | Measuring depth extension (250 mm) for measuring range 250 –800 mm | 844 Nv |
| 4474064 | Measuring depth extension (500 mm) for measuring range 250 –800 mm | 844 Nv |
| 4474066 | Measuring depth extension (250 mm) for measuring range 18 –50 mm | 844 Nv |
| 4474070 | Right angle attachment, Bore depth 45 mm, for measuring range 18 –50 mm | 844 Nw |
| 4474071 | Right angle attachment, Bore depth 55 mm, for measuring range 35 –100 mm | 844 Nw |
| 4474072 | Right angle attachment, Bore depth 70 mm, for measuring range 100 –250 mm | 844 Nw |
| 4470098 | Base for mounting holder 420 h up to 420 mm | 844 ef |
| 4470095 | Measuring jaw (60 x 9.5 x 9 mm), for measuring range 18 –800 mm (for 844 N) | 844 em |



1004



1003



1002



1087 BR



844 em



844 Neb



844 ef

Multimar | Universal measuring instruments

Whether you are measuring gears, threads, cones or grooves, Multimar universal measuring instruments are an ideal solution for almost all internal and external measurements for which standard measuring instruments are unsuitable. A choice of basic units and an extensive range of accessories are available.

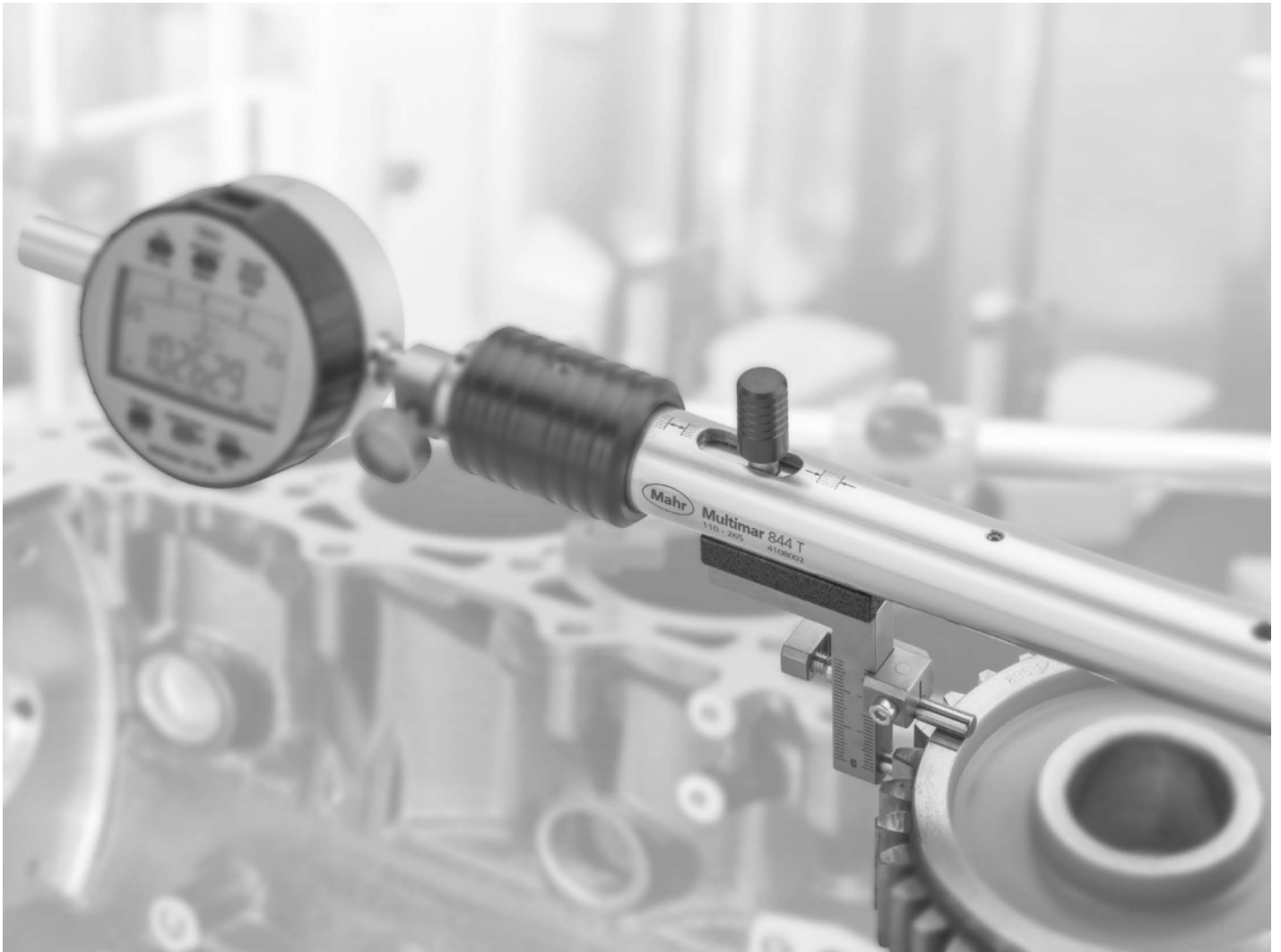

| | |
|---|------------|
| Multimar 25 EWRI / 25 EWR Digital universal caliper | 410 |
| Overview Multimar 844 T universal probe and accessories | 413 |
| Multimar 844 T Universal probe | 416 |
| Multimar 844 Tw Depth stops for measuring arms 844 Tma, 844 Tmi, 844 Te | 418 |
| Multimar 844 Tma / 844 Tmi Mounting attachments | 419 |
| Multimar 844 Tms Mounting attachments with 90° offset | 420 |
| Multimar 844 Ta / 844 Ti Shoulder measuring anvils | 421 |
| Multimar 844 Tb / 844 Tc Measuring anvils with measuring blades | 423 |
| Multimar 844 Td Anvils with round measuring faces | 425 |
| Multimar 844 Tz Cylindrical pin gages | 426 |
| Multimar 844 Te Measuring arms | 427 |
| Multimar 844 Tp / 844 Ts Measuring anvils, flat | 430 |
| Multimar 844 Tk Spherical anvil | 431 |
| Multimar 844 S Setting instrument | 432 |
| Multimar M36B-10 / M36B-20 Indicating measuring instruments | 433 |
| Multimar EDI-36B-10 ...-20 / EMD-36B-10 ...-20D Indicating measuring instruments | 434 |
| Multimar 36B-10 / 36B-20 Indicating measuring instruments | 435 |
| Multimar EDI-36B-19 / EDI-36B-9 / EMD-36B-19D / EMD-36B-9D Indicating measuring instruments | 437 |
| Multimar 36B-19 / 36B-9 / 36B-19M / 36B-9M Indicating measuring instruments | 438 |

Multimar 25 EWRI / 25 EWR

Digital universal calipers

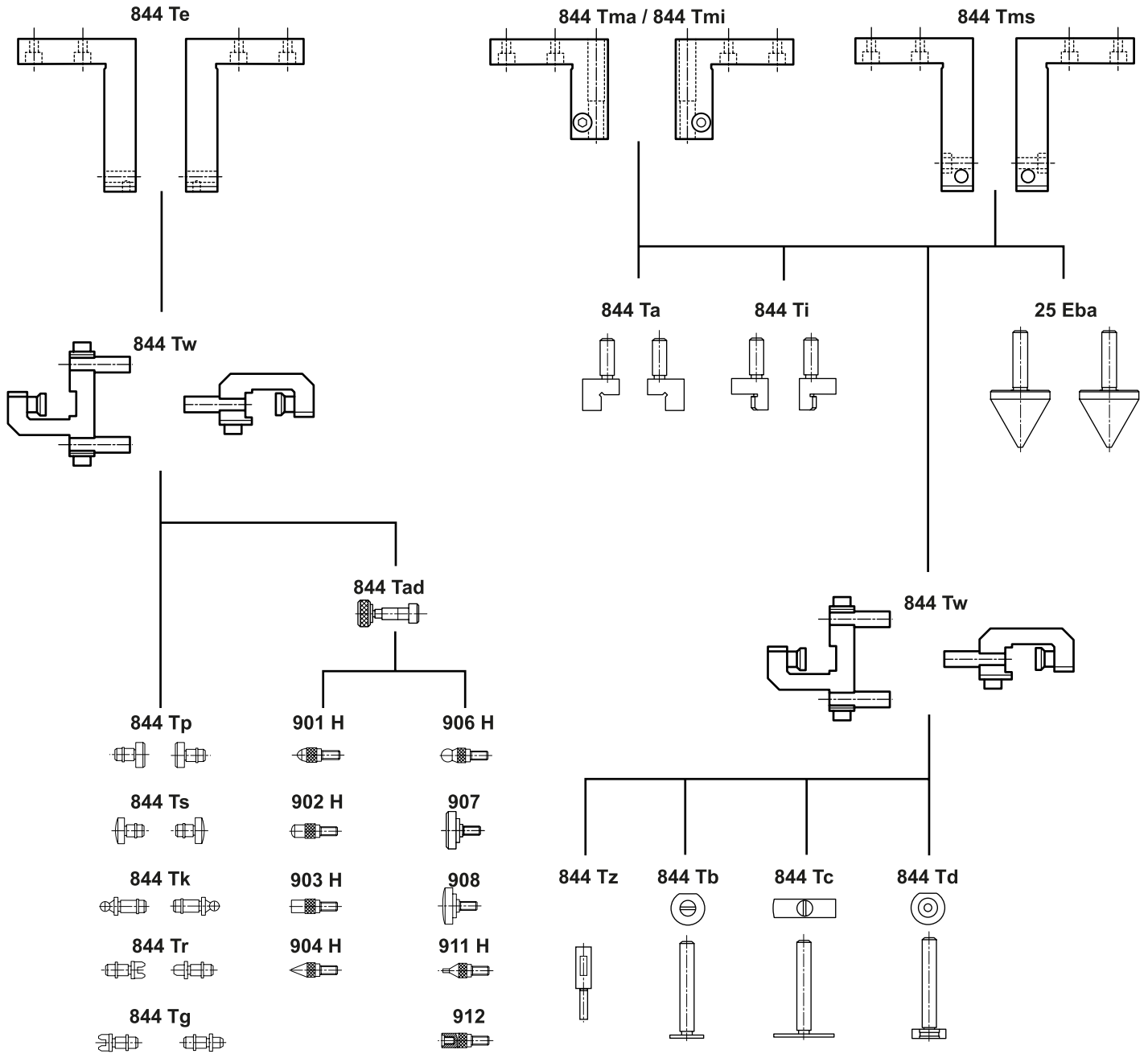

Multimar 25 EWR / 25 EWRi

Digital universal calipers

FUNCTIONS

Functions 25 EWR:

- ON/OFF
- AUTO-ON / OFF
- RESET (set display to zero)
- mm/inch
- PRESET (for entering a numerical value)
- LOCK function (key lock)
- DATA (data transmission via connection cable)



Functions 25 EWRi:

- ON/OFF
- AUTO-ON / OFF
- HOLD (storage of measured values)
- RESET (set display to zero)
- PRESET (for entering a numerical value)
- Reversal of counting direction
- mm/inch
- LOCK function (key lock)
- DATA (data transmission)



- Can be customized to the measuring task due to modular accessories (optional)
- Digital display can always be read as the measuring elements can be installed on the top or bottom
- The application range can be extended by turning the measuring arms
- The two arm holders can be moved along the rail for optimal balance, which is practical with small dimensions
- Slide and rail are made of hardened stainless steel

Applications:

For measuring

- Outside and inside diameters
- Centering shoulders
- Narrow collars
- External and internal tapers
- Dovetails
- Grooves
- Distances between hole centers

TECHNICAL DATA

| Order no. | Type | Application range outside | | Resolution | Error limit |
|-----------|---------|---------------------------|--------|---------------|-------------|
| | | mm | inch | | |
| 4119000 | 25 EWR | 0 – 300 | 0 – 12 | 0.01 / .0005" | 0.03 |
| 4119001 | 25 EWR | 0 – 600 | 0 – 24 | 0.01 / .0005" | 0.03 |
| 4119002 | 25 EWR | 0 – 1000 | 0 – 40 | 0.01 / .0005" | 0.04 |
| 4119003 | 25 EWR | 0 – 1250 | 0 – 50 | 0.01 / .0005" | 0.04 |
| 4119050 | 25 EWRi | 0 – 300 | 0 – 12 | 0.01 / .0005" | 0.03 |
| 4119051 | 25 EWRi | 0 – 600 | 0 – 24 | 0.01 / .0005" | 0.03 |
| 4119052 | 25 EWRi | 0 – 1000 | 0 – 40 | 0.01 / .0005" | 0.04 |
| 4119053 | 25 EWRi | 0 – 1250 | 0 – 50 | 0.01 / .0005" | 0.04 |

FEATURES

25 EWR:

- **Software:** MarCom Professional free download: www.mahr.com/marcom (only for Mahr data cables and wireless systems with USB and RS-232 interface)
- **Data interface:** USB, Digimatic, Opto RS-232C, wireless
- **Energy supply:** Battery life approx. 3 years
- **Battery type:** CR 2032 (3V Lithium)
- **IP protection category:** IP 65
- **Package contains:** battery, instruction manual, mounting and resting blocks, wooden case, without arms/attachments and anvils

25 EWRi:

- **Data interface:** Integrated Wireless
- **Energy supply:** Battery life approx. 3 years (approx. 0.5 in wireless mode)

| Order no. | a |
|-----------|------|
| | mm |
| 4119000 | 480 |
| 4119001 | 790 |
| 4119002 | 1200 |
| 4119003 | 1450 |
| 4119050 | 480 |
| 4119051 | 790 |
| 4119052 | 1200 |
| 4119053 | 1450 |

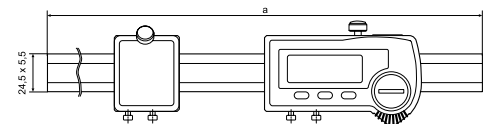



ACCESSORIES

| Order no. | For measuring instrument | Description | Type |
|-----------|---|---|---------|
| 4102220 | 25 EWR | Receiver for instruments with Integrated Wireless | i-Stick |
| 4102231 | 25 EWR | 16 EWe transmitter for e-Stick | 16 EWe |
| 4102357 | 25 EWR | 16 EXu data connection cable USB (2 m) | 16 EXu |
| 4102410 | 25 EWR | Data connection cable RS232C (2 m) | 16 EXr |
| 4102915 | 25 EWR | Interface adapter with data cable Digimatic (2 m) | 16 EWd |
| 4118520 | 25 EWR, 25 EWRi | Setting gage | 25 Eel |
| 4119010 | 25 EWR, 25 EWRi | Measuring tips for drill hole intervals, Ø 2–20 mm | 25 Eba |
| 4119011 | 25 EWR, 25 EWRi | Measuring tips for drill hole intervals, Ø 10–40 mm | 25 Eba |
| 4503020 | 25 EWR, 25 EWRi | Case for accessories | 844 Tzb |
| 4503024 | 25 EWR, 25 EWRi | Measuring arms, 25 mm | 844 Te |
| 4503025 | 25 EWR, 25 EWRi | Measuring arms, 35 mm | 844 Te |
| 4503026 | 25 EWR, 25 EWRi | Measuring arms, 70 mm | 844 Te |
| 4503027 | 25 EWR, 25 EWRi | Measuring arms, 100 mm | 844 Te |
| 4503030 | 25 EWR, 25 EWRi | Mounting attachment | 844 Tma |
| 4503031 | 25 EWR, 25 EWRi | Mounting attachment | 844 Tmi |
| 4503109 | 25 EWR, 25 EWR, 25 EWRi, 25 EWRi, 25 EWRi | Depth stops for 844 Tma, 844 Tmi, 844 Te | 844 Tw |



16 EWe



25 Eel



844 Tma

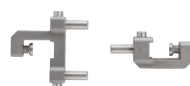

844 Tw



25 Eba



i-Stick

Multimar | Universal gage 844 T for external and internal dimensions

The universal gage Multimar 844 T is easy to use and versatile; ideal for all your measuring requirements in dimensional metrology.

Applications

For measuring:

- External and internal dimensions
- External and internal threads
- Centering shoulders, narrow collars, recesses and grooves
- External and internal tapers, external and internal tooth profiles/gears, etc.

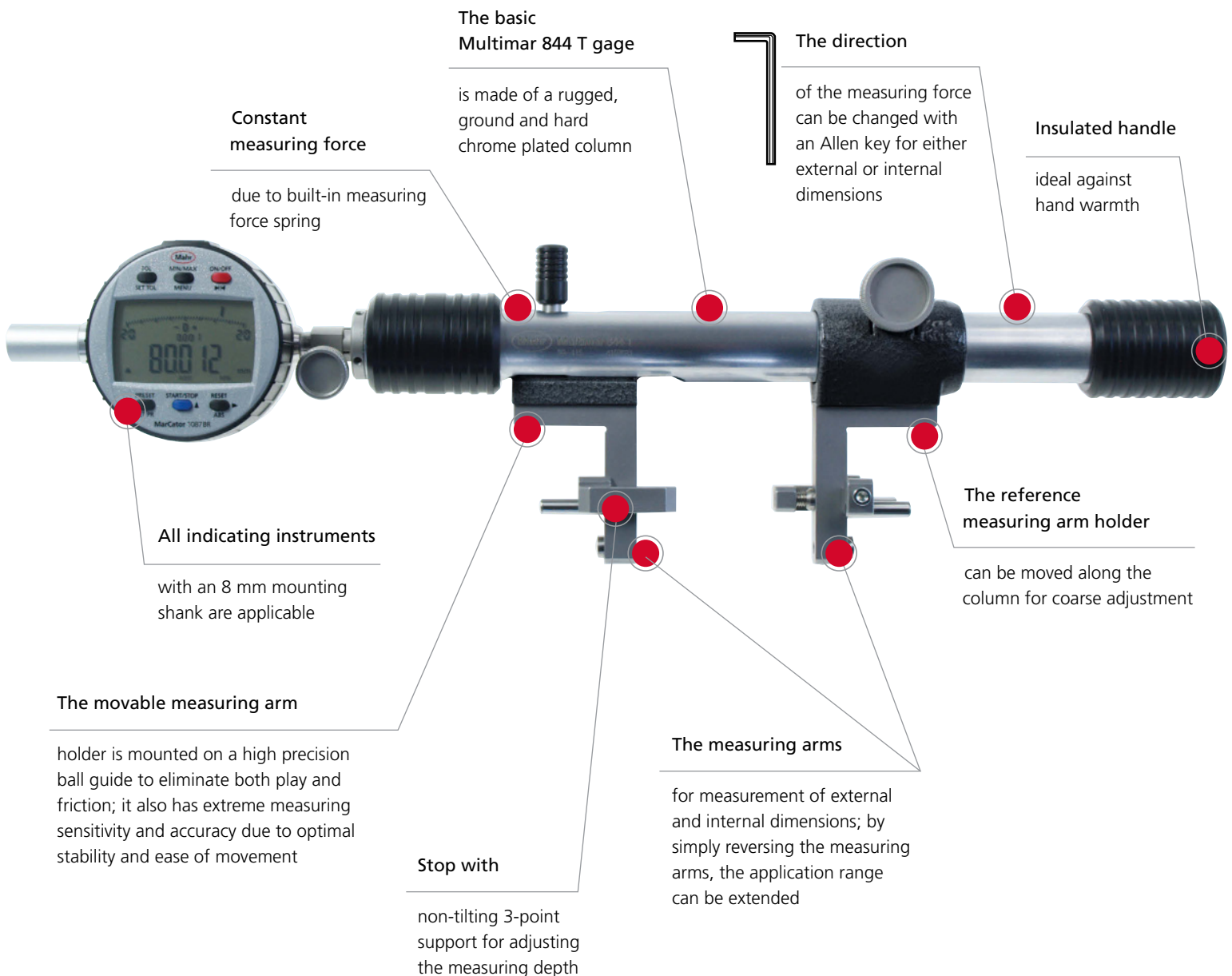

Multimar 844 T

Universal measuring instrument

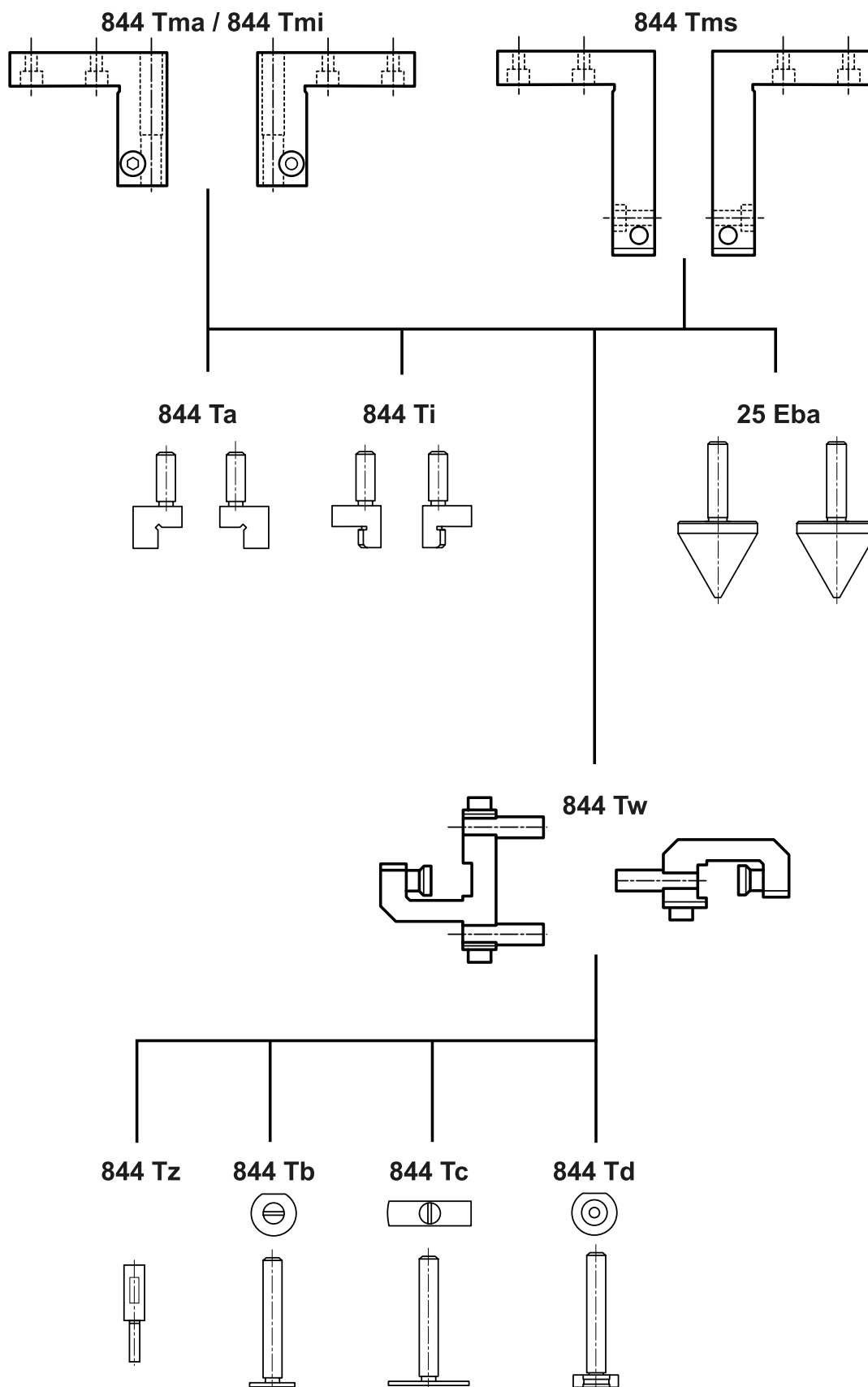

Multimar 844 T

Universal measuring instrument

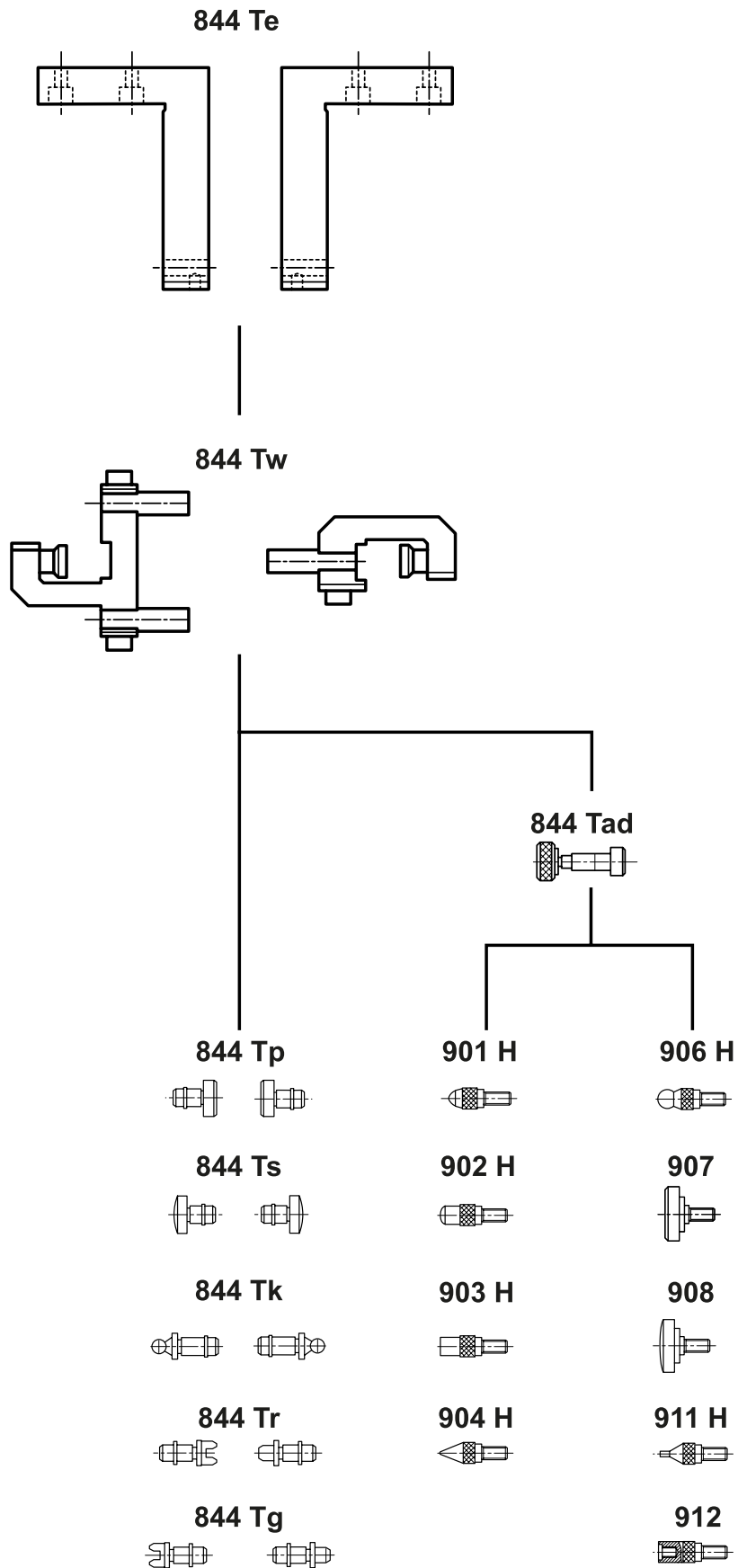

Multimar 844 T

Universal measuring instrument

FEATURES

- For easy adaptation to individual measuring tasks, optional accessories include:
 - Interchangeable measuring arms
 - Contact blocks
 - Stop elements
- The movable measuring arm carrier is mounted on a high precision ball bearing guide for reduced play and friction
 - Results in high measuring sensitivity, accuracy and free movement
- Stable support elements for repeatable measurements
- Constant measuring force with integrated measuring force spring
- Reversible measuring force direction for outside and inside measurement
- Highly stable, precision ground, hard chrome plated guide tube
- Lightweight construction with core made from carbon fiber reinforced plastic (CRP) tube, for measuring range 1000–1500 mm
- The stationary measuring arm holder can be moved along the guide tube and clamped for coarse adjustment
- **Package contains:** instruction manual, mounting and resting blocks, wooden case, excludes indicator, without arms/ attachments and anvils



Applications:

- External and internal measurement of lengths, widths, diameters, distances
- External and internal threads
- Centering shoulders, narrow collars, recesses and grooves
- External and internal tapers
- External and internal gears and more

TECHNICAL DATA

| Order no. | Type | Application range outside | Application range inside | Measuring force | Probe path | Product weight |
|-----------|-------|---------------------------|--------------------------|-----------------|------------|----------------|
| | | mm | mm | N | mm | kg |
| 4503001 | 844 T | 0 –85 | 30 –115 | 5 | 12 | 0.78 |
| 4503002 | 844 T | 80 –235 | 110 –265 | 5 | 12 | 1.01 |
| 4503003 | 844 T | 230 –585 | 260 –615 | 5 | 12 | 1.59 |
| 4503004 | 844 T | 580 –985 | 610 –1015 | 5 | 12 | 2.22 |
| 4503005 | 844 T | 970 –1470 | 1000 –1500 | 10 | 12 | 2.52 |
| 4503006 | 844 T | 1470 –1970 | 1500 –2000 | 10 | 12 | 2.68 |
| 4503007 | 844 T | 1970 –2470 | 2000 –2500 | 10 | 12 | 2.86 |
| 4503008 | 844 T | 2470 –2970 | 2500 –3000 | 10 | 12 | 3.26 |
| 4503009 | 844 T | 2970 –3470 | 3000 –3500 | 10 | 12 | 3.43 |
| 4503010 | 844 T | 3470 –3970 | 3500 –4000 | 10 | 12 | 3.62 |
| 4503011 | 844 T | 3970 –4470 | 4000 –4500 | 10 | 12 | 3.81 |

Multimar 844 T

Universal measuring instrument

ACCESSORIES

| Order no. | Description | Quantity unit | Type |
|-----------|---|---------------|----------|
| 4311000 | Dial indicator, 0.01, 10 mm | | 810 S |
| 4333000 | Millimess 5 μm , $\pm 130 \mu\text{m}$ | | 1004 |
| 4332000 | Millimess 0.01, $\pm 0,25 \text{ mm}$ | | 1010 |
| 4337662 | Digital indicator, 0.0005 mm, 12.5 mm | | 1087 BR |
| 4337664 | Digital indicator, 0.0005 mm, 12.5 mm | | 1087 BRi |
| 4503030 | Mounting attachment | Pair | 844 Tma |
| 4503031 | Mounting attachment | Pair | 844 Tmi |
| 4503024 | Measuring arms, 25 mm | Pair | 844 Te |
| 4503025 | Measuring arms, 35 mm | Pair | 844 Te |
| 4503026 | Measuring arms, 70 mm | Pair | 844 Te |
| 4503027 | Measuring arms, 100 mm | Pair | 844 Te |
| 4503040 | Mounting attachments offset by 90°, 50 mm | Pair | 844 Tms |
| 4503041 | Mounting attachments offset by 90°, 100 mm | Pair | 844 Tms |
| 4503109 | Depth stops for 844 Tma, 844 Tmi, 844 Te | Pair | 844 Tw |
| 4503012 | Guard bracket for display units | | 844 Tsb |
| 4503020 | Case for accessories | | 844 Tzb |
| 4450512 | Stand | | 844 Tf |



810 S



1004



1087 BR



844 Tma

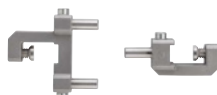

844 Tw

Multimar 844 Tw

Depth stops for 844 Tma, 844 Tmi, 844 Te

FEATURES

- Stops with stall protected 3-point support
- Hardened stop pins
- Interchangeable and adjustable
- **Package contents:**
 - 1 pair of stop pieces with 3 stop pins $\varnothing 5 \times 20$ mm
 - Additionally 1 stop pin each $\varnothing 5 \times 16$ mm and $\varnothing 5 \times 10$ mm for stop piece 1-point

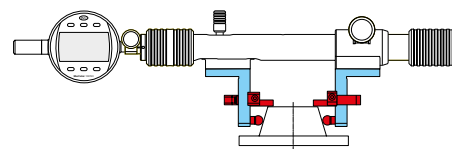
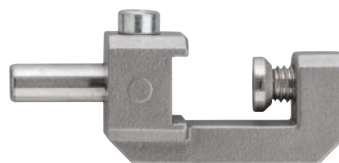
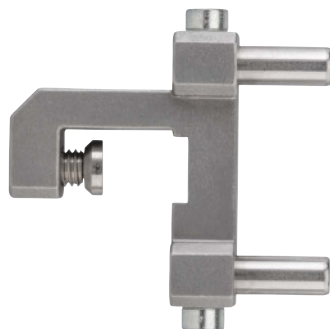

Applications:

- For adjustment of the measuring depth in horizontal measuring position
- Precise stops in one plane for repeatable measurements
- To be mounted on 844 Tma, 844 Tmi, 844 Te
- For easy setting of the measuring depth, a mm scale is engraved on the measuring arms 844 Tma, 844 Tmi and 844 Te
- For precise setting of the measuring depth (i.e. for taper measurements) gage blocks can be used

TECHNICAL DATA

| Order no. | Type |
|-----------|--------|
| 4503109 | 844 Tw |

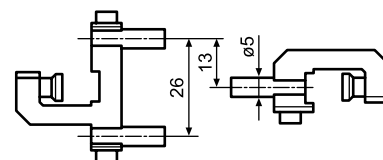

Multimar 844 Tma / 844 Tmi

Mounting attachment

FEATURES

- For outside (844 Tma) and inside diameters (844 Tmi)
- Stainless steel
- Lateral mm scale for easy positioning and adjustment of measuring limit stops
- Reversible measuring arms on measuring arm holders to increase the measuring range
- With $\varnothing 5$ mm mounting bore for inserting interchangeable 844 Ta, 844 Ti, 844 Tb, 844 Tc, 844 Td, 844 Tz and 844 Tv measuring anvils

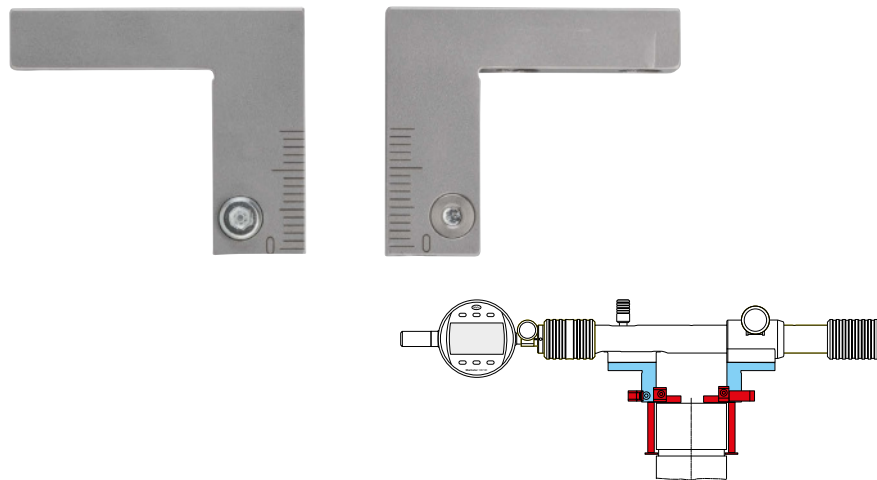

TECHNICAL DATA

| Order no. | Mounting hole | Type |
|-----------|---------------|---------|
| | mm | |
| 4503030 | 5 | 844 Tma |
| 4503031 | 5 | 844 Tmi |

| Order no. | a | b | Mounting hole |
|-----------|----|----|---------------|
| | mm | mm | mm |
| 4503030 | 24 | 32 | 5 |
| 4503031 | 24 | 32 | 5 |

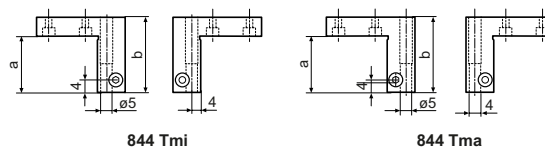

ACCESSORIES

| Order no. | Description | Quantity unit | Type |
|-----------|--|---------------|--------|
| 4119010 | Measuring tips for drill hole intervals, $\varnothing 2-20$ mm | Piece | 25 Eba |
| 4119011 | Measuring tips for drill hole intervals, $\varnothing 10-40$ mm | Piece | 25 Eba |
| 4500050 | Shoulder anvils, flat, hardened steel | Pair | 844 Ta |
| 4500055 | Shoulder anvils, spherical, hardened steel | Pair | 844 Ti |
| 4503015 | Measuring anvils with measuring blades, platelet diameter 11 mm, adjustment range 0–20 mm | Piece | 844 Tb |
| 4503016 | Measuring anvils with measuring blades, platelet diameter 11 mm, adjustment range 20–40 mm | Piece | 844 Tb |
| 4503017 | Anvils with round measuring faces, diameter 11 mm, adjustment range 0–20 mm | Piece | 844 Td |
| 4503018 | Anvils with round measuring faces, diameter 11 mm, adjustment range 20–40 mm | Piece | 844 Td |
| 4503109 | Depth stops for 844 Tma, 844 Tmi, 844 Te | Pair | 844 Tw |
| 4503114 | Measuring anvils with measuring blades, platelet length 20 mm, adjustment range 0–20 mm | Piece | 844 Tc |
| 4503115 | Measuring anvils with measuring blades, platelet length 20 mm, adjustment range 20–40 mm | Piece | 844 Tc |

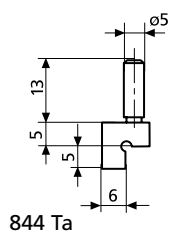

844 Ta

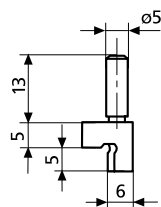

844 Ti

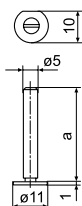

844 Tb

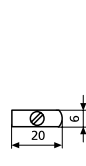

844 Tc

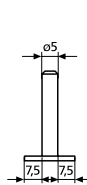

844 Td

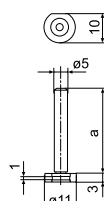

25 Eba

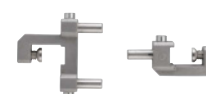

844 Tw

Multimar 844 Tms

Mounting attachments offset by 90°

FEATURES

- For outer and inner diameters
- Stainless steel
- Reversible measuring arms on measuring arm holders to increase the measuring range
- With $\varnothing 5$ mm holder for inserting interchangeable 844 Ta, 844 Ti, 844 Tb, 844 Tc, 844 Td, 844 Tz and 844 Tv measuring anvils

Applications:

- For measuring outer and inner dimensions with side probes:
 - In flat recesses
 - In holes with center hub
 - In holes with retracted drill rod

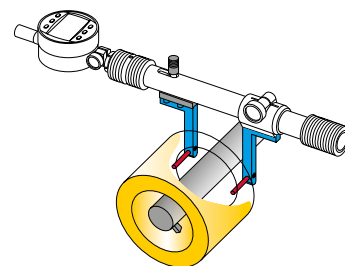

TECHNICAL DATA

| Order no. | Mounting hole | Throat depth | Type |
|-----------|---------------|--------------|---------|
| | mm | mm | |
| 4503040 | 5 | 50 | 844 Tms |
| 4503041 | 5 | 100 | 844 Tms |

| Order no. | b | Mounting hole |
|-----------|----|---------------|
| | mm | mm |
| 4503040 | 12 | 5 |
| 4503041 | 12 | 5 |

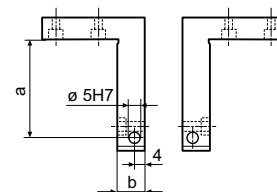

ACCESSORIES

| Order no. | Description | Type |
|-----------|---|--------|
| 4500050 | Shoulder anvils, flat, hardened steel | 844 Ta |
| 4500055 | Shoulder anvils, spherical, hardened steel | 844 Ti |
| 4503015 | Measuring anvils with measuring blades, platelet diameter 11 mm, adjustment range 0 –20 mm | 844 Tb |
| 4503016 | Measuring anvils with measuring blades, platelet diameter 11 mm, adjustment range 20 –40 mm | 844 Tb |
| 4503017 | Anvils with round measuring faces, diameter 11 mm, adjustment range 0 –20 mm | 844 Td |
| 4503018 | Anvils with round measuring faces, diameter 11 mm, adjustment range 20 –40 mm | 844 Td |
| 4503114 | Measuring anvils with measuring blades, platelet length 20 mm, adjustment range 0 –20 mm | 844 Tc |
| 4503115 | Measuring anvils with measuring blades, platelet length 20 mm, adjustment range 20 –40 mm | 844 Tc |
| 4503119 | Measuring anvils, ball diameter 6 mm, adjustment range 20 –40 mm | 844 To |

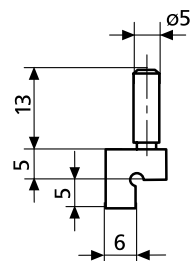

844 Ta

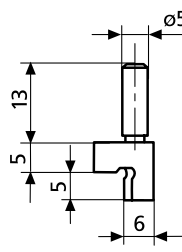

844 Ti

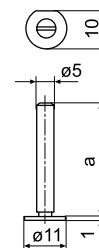

844 Tb

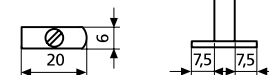

844 Tc

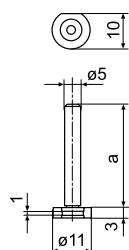

844 Td



844 To

Multimar 844 Ta

Shoulder anvils

FEATURES

- With cylindrical mounting shaft to attach into mounting attachments 844 Tma, 844 Tmi, 844 Tms
- Flat, for external diameter
- Made of hardened steel

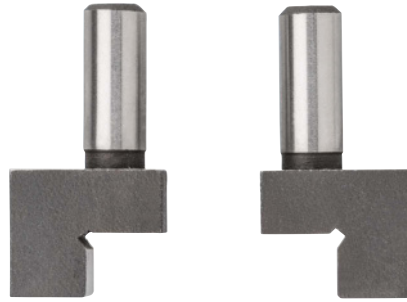

Application:

- For narrow collars such as centering shoulders and other similar measuring tasks

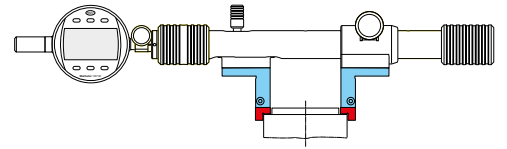

TECHNICAL DATA

| Order no. | Mounting shaft diameter | Type |
|-----------|-------------------------|--------|
| | mm | |
| 4500050 | 5 | 844 Ta |

| Order no. | Mounting ϕ d |
|-----------|-------------------|
| | mm |
| 4500050 | 5 |

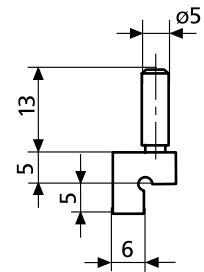

Multimar 844 Ti

Shoulder anvils

FEATURES

- With cylindrical mounting shaft to attach into mounting attachments 844 Tma, 844 Tmi, 844 Tms
- Semi-cylindrical, for internal diameters
- Made of hardened steel

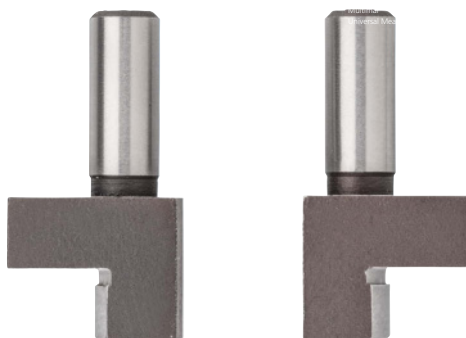

Application:

- For narrow collars such as centering shoulders and other similar measuring tasks

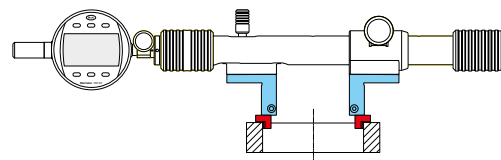

TECHNICAL DATA

| Order no. | Mounting shaft diameter | Type |
|-----------|-------------------------|--------|
| 4500055 | mm 5 | 844 Ti |

| Order no. | Mounting $\varnothing d$ |
|-----------|--------------------------|
| 4500055 | mm 5 |

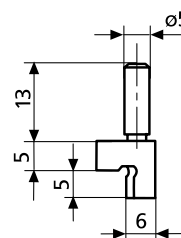

Multimar 844 Tb

Measuring anvils with measuring blades

FEATURES

- With cylindrical mounting shaft to attach into mounting attachments 844 Tma, 844 Tmi, 844 Tms
- Can be moved in the mounting attachment for setting the measuring depth
- With round measuring blade for inner and outer measurements
- Suitable for workpieces with narrow recesses up to 3 mm deep
- Made of hardened steel

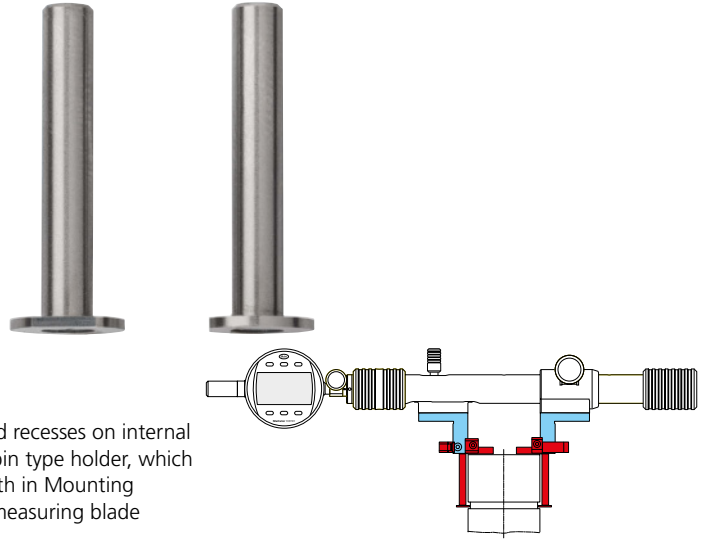

Application:

- For measuring centering shoulders and recesses on internal and external diameters; consists of a pin type holder, which is moved to set the measuring depth in Mounting Attachment 844 Tm and a mounted measuring blade

TECHNICAL DATA

| Order no. | Adjustment range | Mounting shaft diameter | Type |
|-----------|------------------|-------------------------|--------|
| | mm | mm | |
| 4503015 | 0 –20 | 5 | 844 Tb |
| 4503016 | 20 –40 | 5 | 844 Tb |

| Order no. | a | Mounting ϕ d |
|-----------|----|-------------------|
| | mm | mm |
| 4503015 | 30 | 5 |
| 4503016 | 50 | 5 |

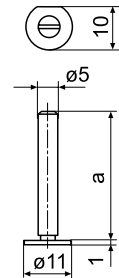

Multimar 844 Tc

Measuring anvils with measuring blades

FEATURES

- With cylindrical mounting shaft to attach into mounting attachments 844 844 Tma, 844 Tmi, 844 Tms
- Can be moved in the mounting attachment for setting the measuring depth
- With long measuring blade
- Suitable for workpieces with narrow recesses up to 7.5 mm deep
- Made of hardened steel

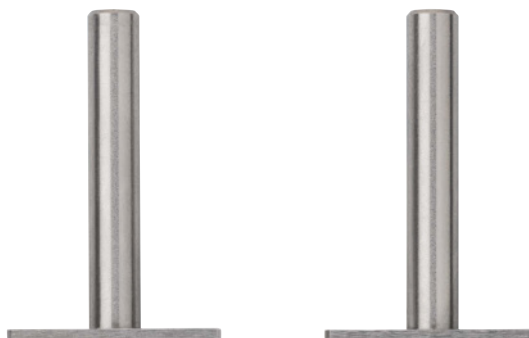

Application:

- For measuring centering shoulders and recesses on internal and external diameter

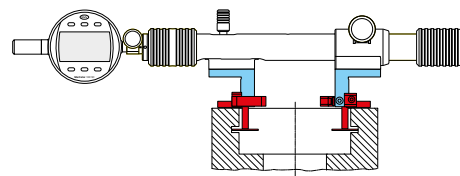

TECHNICAL DATA

| Order no. | Adjustment range | Mounting shaft diameter | Type |
|-----------|------------------|-------------------------|--------|
| | mm | mm | |
| 4503114 | 0 – 20 | 5 | 844 Tc |
| 4503115 | 20 – 40 | 5 | 844 Tc |

| Order no. | a | Mounting ϕ d |
|-----------|----|-------------------|
| | mm | mm |
| 4503114 | 30 | 5 |
| 4503115 | 50 | 5 |

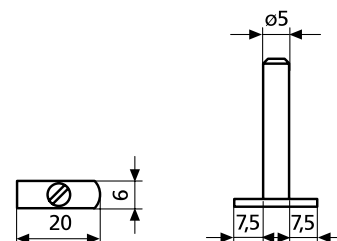

Multimar 844 Td

Anvils with round measuring faces

FEATURES

- With cylindrical mounting shaft to attach into mounting attachments 844 Tma, 844 Tmi, 844 Tms
- Made of hardened steel
- Can be moved in the mounting attachment for setting the measuring depth
- Circular probe for inner and outer measurements
 - Ø 11 mm spherical (R=8 mm)
 - Plane measuring surface (6 x 1 mm)



Application:

- For measuring internal and external dimensions on round or cylindrical parts

TECHNICAL DATA

| Order no. | Adjustment range | Mounting shaft diameter | Type |
|-----------|------------------|-------------------------|--------|
| | mm | mm | |
| 4503017 | 0 –20 | 5 | 844 Td |
| 4503018 | 20 –40 | 5 | 844 Td |

| Order no. | a | Mounting ø d |
|-----------|----|--------------|
| | mm | mm |
| 4503017 | 30 | 5 |
| 4503018 | 50 | 5 |

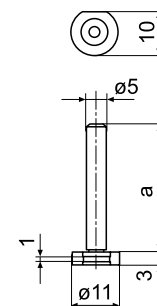

Multimar 844 Tz

Cylindrical measuring pins

FEATURES

- With cylindrical holding shaft for fixing in 844 Tma / 844 Tmi mounting attachments
- Made of hardened steel



Application:

- Determination of the dimension over 2 pins for inner and outer gears

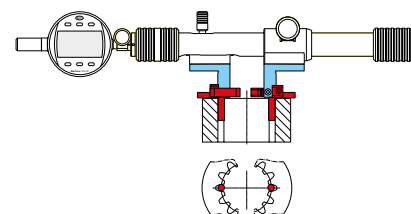

TECHNICAL DATA

| Order no. | D | Mounting shaft diameter | Manufacturing tolerance +/- | Type |
|-----------|------|-------------------------|-----------------------------|--------|
| | mm | mm | µm | |
| 4500500 | 1 | 5 | 2 | 844 Tz |
| 4500501 | 1.25 | 5 | 2 | 844 Tz |
| 4500502 | 1.5 | 5 | 2 | 844 Tz |
| 4500503 | 1.75 | 5 | 2 | 844 Tz |
| 4500504 | 2 | 5 | 2 | 844 Tz |
| 4500506 | 2.5 | 5 | 2 | 844 Tz |
| 4500507 | 3 | 5 | 2 | 844 Tz |
| 4500508 | 3.5 | 5 | 2 | 844 Tz |
| 4500509 | 4 | 5 | 2 | 844 Tz |
| 4500510 | 4.5 | 5 | 2 | 844 Tz |
| 4500511 | 5 | 5 | 2 | 844 Tz |
| 4500512 | 5.5 | 5 | 2 | 844 Tz |
| 4500513 | 6 | 5 | 2 | 844 Tz |

| Order no. | D | Dimension L | l | Mounting ø d |
|-----------|------|-------------|----|--------------|
| | mm | mm | mm | mm |
| 4500500 | 1 | 19.5 | 6 | 5 |
| 4500501 | 1.25 | 19.5 | 6 | 5 |
| 4500502 | 1.5 | 19.5 | 6 | 5 |
| 4500503 | 1.75 | 23.5 | 10 | 5 |
| 4500504 | 2 | 23.5 | 10 | 5 |
| 4500506 | 2.5 | 23.5 | 10 | 5 |
| 4500507 | 3 | 28.5 | 15 | 5 |
| 4500508 | 3.5 | 28.5 | 15 | 5 |
| 4500509 | 4 | 28.5 | 15 | 5 |
| 4500510 | 4.5 | 33.5 | 20 | 5 |
| 4500511 | 5 | 33.5 | 20 | 5 |
| 4500512 | 5.5 | 33.5 | 20 | 5 |
| 4500513 | 6 | 33.5 | 20 | 5 |

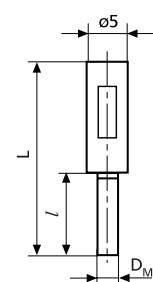

Multimar 844 Te

Measuring arms

FEATURES

- For outer and inner diameters
- Stainless steel
- Lateral mm scale for easy positioning and adjustment of measuring limit stops
- Reversible measuring arms on measuring arm holder to increase the measuring range
- 3.5 mm diameter holder for inserting interchangeable measuring anvils 844 Tp, 844 Ts, 844 Tk, 844 Tr and 844 Tg

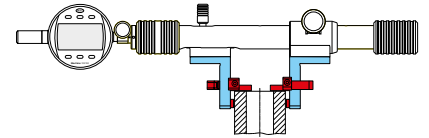

TECHNICAL DATA

| Order no. | Mounting hole | Throat depth | Type |
|-----------|---------------|--------------|--------|
| | mm | mm | |
| 4503024 | 3.5 | 25 | 844 Te |
| 4503025 | 3.5 | 35 | 844 Te |
| 4503026 | 3.5 | 70 | 844 Te |
| 4503027 | 3.5 | 100 | 844 Te |

| Order no. | b | Mounting hole |
|-----------|----|---------------|
| | mm | mm |
| 4503024 | 6 | 3.5 |
| 4503025 | 10 | 3.5 |
| 4503026 | 10 | 3.5 |
| 4503027 | 12 | 3.5 |

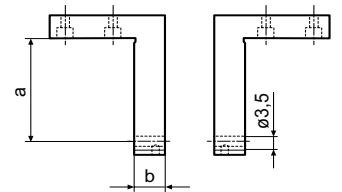

ACCESSORIES

| Order no. | Description | Quantity unit | Type |
|-----------|--|---------------|---------|
| 4500040 | Anvils for measuring arms, flat, hardened steel | Piece | 844 Tp |
| 4500045 | Measuring anvils, spherical, hardened steel | Piece | 844 Ts |
| 4503080 | Adapter \varnothing 3.5 - M2,5 for measuring arms 844 Te | Piece | 844 Tad |
| 4503109 | Depth stops for 844 Tma, 844 Tmi, 844 Te | Pair | 844 Tw |

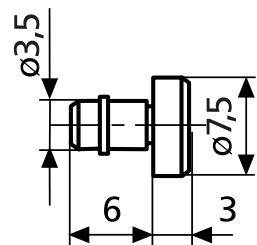

844 Tp

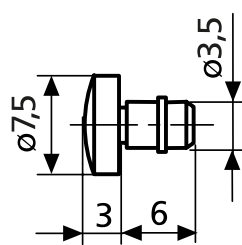

844 Ts

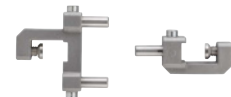

844 Tw

Multimar thread anvils

Measuring arms

FEATURES

- For pitch diameters
- Hardened, wear-resistant special steel
- With cylindrical mounting shank and retainer ring which ensures locking while permitting rotation in bore

ACCESSORIES

| Thread pitch | Blade Order no. | Taper Order no. | V-anvil Order no. |
|--|-----------------|-----------------|-------------------|
| Pitch diameter, external thread | | | |
| Metric 60° | | | |
| 0.5 -0.7 | | 4501000 | 4501200 |
| 0.7 -1 | | 4501001 | 4501201 |
| 1.25 -2 | | 4501002 | 4501202 |
| 2 -3.5 | | 4501003 | 4501203 |
| 3.5 -5 | | 4501004 | 4501204 |
| 5 -7 | | 4501005 | 4501205 |

| | | | |
|----------------------|--|---------|---------|
| Trapezoid 30° | | | |
| 1.5 | | 4501151 | 4501351 |
| 2 | | 4501152 | 4501352 |
| 3 | | 4501153 | 4501353 |
| 4 | | 4501154 | 4501354 |
| 5 | | 4501155 | 4501355 |
| 6 | | 4501156 | 4501356 |
| 7 | | 4501157 | 4501357 |
| 8 | | 4501158 | 4501358 |
| 9 | | 4501159 | 4501359 |
| 10 | | 4501160 | 4501360 |
| 12 | | 4501161 | 4501361 |
| 14 | | 4501162 | 4501362 |
| 16 | | 4501163 | 4501363 |
| 18 | | 4501164 | 4501364 |
| 20 | | 4501165 | 4501365 |

| | | | |
|--|---------|---------|--|
| Pitch diameter, internal thread | | | |
| Metric 60° | | | |
| 0.5 -0.7 | 4174600 | 4174300 | |
| 0.7 -1 | 4174601 | 4174301 | |
| 1.25 -2 | 4174602 | 4174302 | |
| 2 -3.5 | 4174603 | 4174303 | |
| 3.5 -5 | 4174604 | 4174304 | |
| 5 -7 | 4174605 | 4174305 | |

| | | | |
|----------------------|---------|---------|--|
| Trapezoid 30° | | | |
| 1,5 | 4501833 | 4501832 | |
| 2 | 4501835 | 4501834 | |
| 3 | 4501837 | 4501836 | |
| 4 | 4501839 | 4501838 | |
| 5 | 4501841 | 4501840 | |
| 6 | 4501843 | 4501842 | |
| 7 | 4501845 | 4501844 | |
| 8 | 4501847 | 4501846 | |
| 9 | 4501849 | 4501848 | |
| 10 | 4501851 | 4501850 | |
| 12 | 4174981 | 4174961 | |

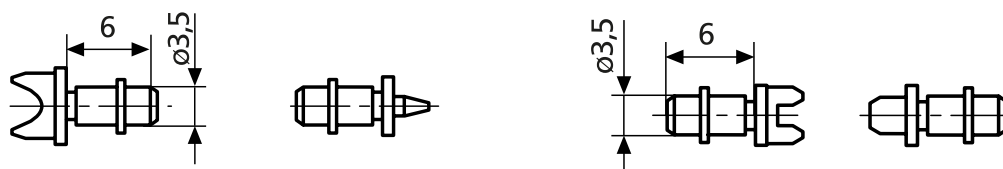

Multimar thread anvils

Measuring arms

FEATURES

- For pitch diameters
- Hardened, wear-resistant special steel
- With cylindrical mounting shank and retainer ring which ensures locking while permitting rotation in bore

ACCESSORIES

| Thread pitch in TPI | Blade Order no. | Taper Order no. | V-anvil Order no. |
|--|--------------------|--------------------|----------------------|
| Pitch diameter, external thread | | | |
| UST 60° | | | |
| 40-32 | | 4501018 | 4501418 |
| 32-24 | | 4501019 | 4501419 |
| 24-18 | | 4501020 | 4501420 |
| 18-14 | | 4501021 | 4501421 |
| 14-10 | | 4501022 | 4501422 |
| 10-7 | | 4501023 | 4501423 |
| 7-4.5 | | 4501024 | 4501424 |
| 4.5-3 | | 4501025 | 4501425 |
| Whitworth 55° | | | |
| 40-32 | | 4501007 | 4501207 |
| 32-24 | | 4501008 | 4501208 |
| 24-18 | | 4501009 | 4501209 |
| 18-14 | | 4501010 | 4501210 |
| 14-10 | | 4501011 | 4501211 |
| 10-7 | | 4501012 | 4501212 |
| 7-4.5 | | 4501013 | 4501213 |
| 4.5-3 | | 4501014 | 4501214 |
| Pitch diameter, internal thread | | | |
| UST 60° | | | |
| 40-32 | 4174615 | 4174415 | |
| 32-24 | 4174616 | 4174416 | |
| 24-18 | 4174617 | 4174417 | |
| 18-14 | 4174618 | 4174418 | |
| 14-10 | 4174919 | 4174419 | |
| 10-7 | 4174620 | 4174420 | |
| 7-4.5 | 4174621 | 4174421 | |
| 4.5-3 | 4174622 | 4174422 | |
| Whitworth 55° | | | |
| 40-32 | 4174643 | 4174343 | |
| 32-24 | 4174644 | 4174344 | |
| 24-18 | 4174645 | 4174345 | |
| 18-14 | 4174646 | 4174346 | |



Multimar 844 Tp

Anvils for measuring arms

FEATURES

- Made of hardened steel
- With cylindrical mounting shank and retainer ring which allows free rotation inside the bore of measuring arms 844 Te

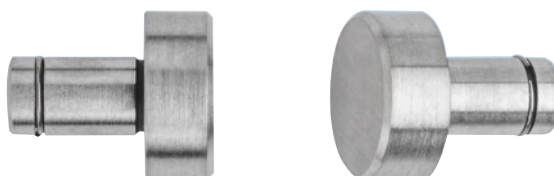

Application:

- Flat; for external diameters, distances and widths

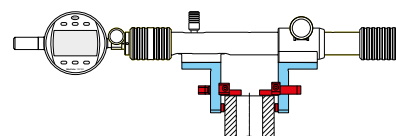

TECHNICAL DATA

| Order no. | Mounting shaft diameter | Type |
|-----------|-------------------------|--------|
| 4500040 | mm 3.5 | 844 Tp |

Multimar 844 Ts

Measuring anvils

FEATURES

- Made of hardened steel
- With cylindrical mounting shank and retainer ring which allows free rotation inside the bore of measuring arms 844 Te



Application:

- Spherical; for internal diameters

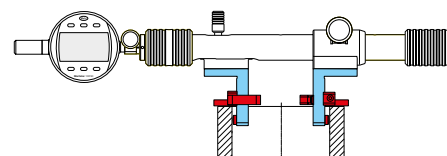

TECHNICAL DATA

| Order no. | Mounting shaft diameter | Type |
|-----------|-------------------------|--------|
| 4500045 | mm 3.5 | 844 Ts |

Multimar 844 Tk

Ball anvil

FEATURES

- Measuring ball made of carbide
- With cylindrical mounting shank and retainer ring which allows free rotation inside the bore of measuring arms 844 Te
- Manufacturing tolerance ball $\pm 2 \mu\text{m}$



Applications:

- Especially suited for the measurement of internal or external helical gear wheels
- Use of convex contours
- Use for cone measurements

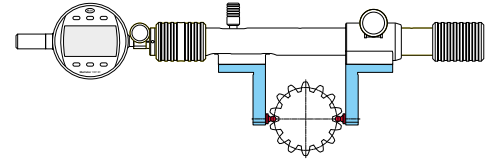

TECHNICAL DATA

| Order no. | Mounting shaft diameter | Type |
|-----------|-------------------------|--------|
| | mm | |
| 4502620 | 3.5 | 844 Tk |
| 4502621 | 3.5 | 844 Tk |
| 4502622 | 3.5 | 844 Tk |
| 4502623 | 3.5 | 844 Tk |
| 4502624 | 3.5 | 844 Tk |
| 4502625 | 3.5 | 844 Tk |
| 4502626 | 3.5 | 844 Tk |
| 4502627 | 3.5 | 844 Tk |
| 4502628 | 3.5 | 844 Tk |
| 4500350 | 3.5 | 844 Tk |
| 4502629 | 3.5 | 844 Tk |
| 4502630 | 3.5 | 844 Tk |
| 4502631 | 3.5 | 844 Tk |
| 4500351 | 3.5 | 844 Tk |
| 4502632 | 3.5 | 844 Tk |
| 4502633 | 3.5 | 844 Tk |
| 4502634 | 3.5 | 844 Tk |
| 4500352 | 3.5 | 844 Tk |
| 4502635 | 3.5 | 844 Tk |
| 4502636 | 3.5 | 844 Tk |
| 4502637 | 3.5 | 844 Tk |
| 4502638 | 3.5 | 844 Tk |
| 4502639 | 3.5 | 844 Tk |
| 4500353 | 3.5 | 844 Tk |
| 4502640 | 3.5 | 844 Tk |
| 4502641 | 3.5 | 844 Tk |
| 4502642 | 3.5 | 844 Tk |
| 4502643 | 3.5 | 844 Tk |
| 4500354 | 3.5 | 844 Tk |
| 4502543 | 3.5 | 844 Tk |
| 4502540 | 3.5 | 844 Tk |
| 4502644 | 3.5 | 844 Tk |
| 4502544 | 3.5 | 844 Tk |
| 4502645 | 3.5 | 844 Tk |
| 4502646 | 3.5 | 844 Tk |
| 4500356 | 3.5 | 844 Tk |
| 4502647 | 3.5 | 844 Tk |
| 4502648 | 3.5 | 844 Tk |
| 4502649 | 3.5 | 844 Tk |
| 4502650 | 3.5 | 844 Tk |
| 4502651 | 3.5 | 844 Tk |
| 4500618 | 3.5 | 844 Tk |
| 4500357 | 3.5 | 844 Tk |

| Order no. | Mounting shaft diameter | Type |
|-----------|-------------------------|--------|
| | mm | |
| 4502652 | 3.5 | 844 Tk |
| 4502541 | 3.5 | 844 Tk |
| 4502653 | 3.5 | 844 Tk |
| 4500358 | 3.5 | 844 Tk |
| 4502654 | 3.5 | 844 Tk |
| 4500359 | 3.5 | 844 Tk |
| 4500360 | 3.5 | 844 Tk |
| 4502655 | 3.5 | 844 Tk |
| 4500361 | 3.5 | 844 Tk |
| 4502656 | 3.5 | 844 Tk |
| 4502657 | 3.5 | 844 Tk |
| 4500362 | 3.5 | 844 Tk |
| 4500363 | 3.5 | 844 Tk |
| 4502658 | 3.5 | 844 Tk |
| 4502545 | 3.5 | 844 Tk |
| 4502542 | 3.5 | 844 Tk |
| 4502547 | 3.5 | 844 Tk |
| 4502548 | 3.5 | 844 Tk |
| 4502549 | 3.5 | 844 Tk |
| 4502550 | 3.5 | 844 Tk |

Multimar 844 S

Setting device

FEATURES

- Simple handling via clamping element
- Accurate setting of nominal value using gage block combinations
- Instrument setting in horizontal or vertical position (using base 844 Sf)
- Rigid base made of anodized aluminum, for mobile or stationary use in production or in the inspection room
- **Package contains:** basic unit 844 S, instruction manual



Application:

- For setting indicating instruments for internal and external dimensions i. e. Multimar 844 T and Marameter 844 N at any dimension by using gage block combinations

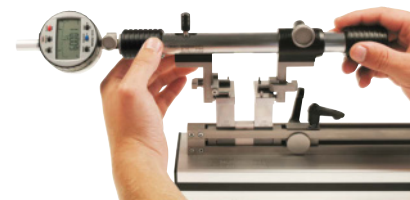

TECHNICAL DATA

| Order no. | | 4503500 | 4503501 | 4503502 |
|----------------------------|------|-------------|-------------|-------------|
| Type | | | 844 S | |
| Application range, outside | mm | 40–400 | 40–1150 | 40–2180 |
| Application range, outside | inch | 1.57"–15.8" | 1.57"–45.2" | 1.57"–85.8" |
| Application range, inside | mm | 0–360 | 0–1110 | 0–2140 |
| Application range, inside | inch | 0"–14.1" | 0"–43.7" | 0"–84.2" |

| Order no. | Instrument dimensions (LxWxH) |
|-----------|-------------------------------|
| 4503500 | 520 x 80 x 40 mm |
| 4503501 | 1270 x 80 x 40 mm |
| 4503502 | 2300 x 80 x 80 mm |

ACCESSORIES

| Order no. | Description | Type |
|-----------|--|---------|
| 4503510 | T-shaped gage blocks (20 mm) for measuring depth up to 40 mm | 844 Sp |
| 4503511 | Riser blocks 30 mm for extended measuring depths | 844 Sph |
| 4474080 | Adjustment bridge (70 x 12 mm), for measuring range 18–250 mm (for 844 N) | 844 Neb |
| 4474081 | Adjustment bridge (165 x 17 mm), for measuring range 18–400 mm (for 844 N) | 844 Neb |
| 4470095 | Measuring jaw (60 x 9,5 x 9 mm), for measuring range 18–800 mm (for 844 N) | 844 em |
| 4503512 | Base for vertical use, including screws and table clamp | 844 Sf |
| 4474082 | Adjustment bridge (320 x 20 mm), for measuring range 18–800 mm (for 844 N) | 844 Neb |



844 Sp

844 Sph

844 Neb

844 em

844 Sf

Multimar M36B-10 / M36B-20

Indicator gage

FEATURES

- Friction-free, zero-backlash measuring anvil holder for high measuring accuracy
- Parallel spring-loaded system for repeatable measuring force
- User-friendly and ergonomic:
 - Table surface can be tilted and clamped between 0° and 90°
 - Adjustable lifting of movable probe
- Adjustable measuring force
- **Package contents:** 3-part measuring anvil holder set, type JW-69 (mounting bore for 5 mm shaft), including standard steel measuring anvils and operating instructions

Applications:

- For measuring inside and outside dimensions: diameters, lengths, distances between bores, offsets, etc.
- Measurement in bores, outside surfaces, recesses, centering shoulders, etc.

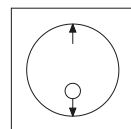

without centralizer

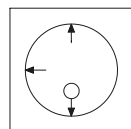

with centralizer

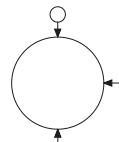

external



TECHNICAL DATA

| Order no. | | 2003200 | 2003201 | 2050644 | 2050648 |
|---|------|------------|-------------|----------------------------|-------------|
| Type | | M36B-10 | M36B-20 | 36B-10M | 36B-20M |
| Application range, outside | mm | 6.5 – 125 | 6.5 – 222 | 6.5 – 125 | 6.5 – 222 |
| Application range, outside | inch | .25 – 5" | .25 – 8.75" | .25 – 5" | .25 – 8.75" |
| Application range, inside | mm | 20 – 130 | 20 – 197 | 20 – 130 | 20 – 197 |
| Application range, inside | inch | .75 – 5.1" | .75 – 7.75" | .75 – 5.1" | .75 – 7.75" |
| Measuring force, adjustable | N | 0 – 35 | | | |
| Probe path, adjustable | mm | 6 – 10 mm | | | |
| Probe path, adjustable | inch | .25 – .40" | | | |
| Indicating instrument (included in package) | | None | | IDS-317 indicator (Q11-RC) | |

| Order no. | Mounting hole |
|-----------|---------------|
| | mm |
| 2003200 | 8 |
| 2003201 | 8 |
| 2050644 | |
| 2050648 | |

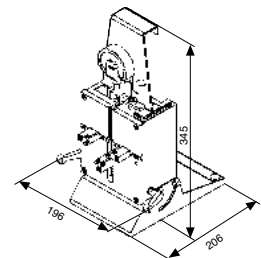

ACCESSORIES

| Order no. | Description | Quantity unit | Type |
|-----------|--|---------------|----------|
| 4337662 | Digital indicator, 0.0005 mm, 12.5 mm | | 1087 BR |
| 4337664 | Digital indicator, 0.0005 mm, 12.5 mm | | 1087 Bri |
| 2220461 | Set of measuring elements with measuring anvils made of hardened steel, for metric version M36B-10 / M36B-20 | Set (3 Pc.) | JW-69 |
| 2225694 | Separate measuring anvils for JW-69M / 2220461 measuring elements, made of hardened steel | Piece | PS-276 |
| 2220455 | Jaw set of measuring elements, with measuring anvils made of carbide | Set (3 Pc.) | JW-58 |
| 2225676 | Separate measuring anvils for JW-58 / 2003211 measuring elements, made of carbide | Piece | PS-226 |
| 4500050 | Shoulder anvils, flat, hardened steel | Pair | 844 Ta |
| 4500055 | Shoulder anvils, spherical, hardened steel | Pair | 844 Ti |
| 4503015 | Measuring anvils with measuring blades, platelet diameter 11 mm, adjustment range 0 – 20 mm | Piece | 844 Tb |
| 4503114 | Measuring anvils with measuring blades, platelet length 20 mm, adjustment range 0 – 20 mm | Piece | 844 Tc |
| 4503017 | Anvils with round measuring faces, diameter 11 mm, adjustment range 0 – 20 mm | Piece | 844 Td |

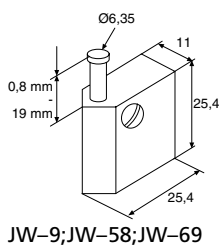

JW-9; JW-58; JW-69

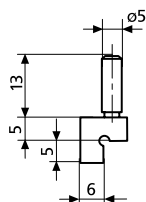

844 Ta



1087 BR

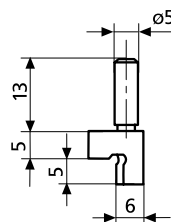

844 Ti



844 Tc

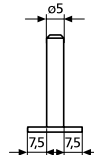

844 Tb

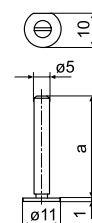

844 Td

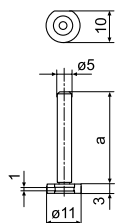

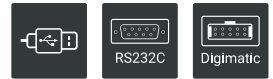

FEATURES

- Friction-free, zero-backlash measuring anvil holder for high measuring accuracy
- Parallel spring-loaded system for repeatable measuring force
- User-friendly and ergonomic:
 - Table surface can be tilted and clamped between 0° and 90°
 - Adjustable lifting of movable probe
- Adjustable measuring force
- **Data interface:** Digimatic, RS-232C, USB
- **Energy supply:** battery operation
- **Package contains:** set of jaws JW-9, instruction manual

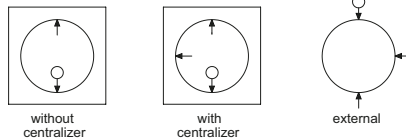

Applications:

- For measuring inner and outer diameters, centering shoulders, narrow collars and recesses
- Support plate with scale to help easily set the diameter
- Third measuring contact as lateral stop or centering device



TECHNICAL DATA

| Order no. | 2051693 | 2051695 | 2051863 | 2051864 | 2051873 | 2051874 |
|---|----------------------|------------------|----------------------|----------------------|----------------------|----------------------|
| Type | EDI-36B-10 | EDI-36B-20 | EMD-36B-10 | EMD-36B-10D | EMD-36B-20 | EMD-36B-20D |
| Application range, outside | mm 6 – 127 | mm 6 – 222 | mm 6 – 127 | | mm 6 – 222 | |
| Application range, outside | inch .25 – 5" | inch .25 – 8.75" | inch .25 – 5" | | inch .25 – 8.75" | |
| Application range, inside | mm 19 – 89 | mm 19 – 197 | mm 19 – 89 | | mm 19 – 197 | |
| Application range, inside | inch .75 – 3.5" | inch .75 – 7.75" | inch .75 – 3.5" | | inch .75 – 7.75" | |
| Measuring force, adjustable | N | | 0 – 35 | | | |
| Probe path, adjustable | mm | | 6 – 10 | | | |
| Probe path, adjustable | inch | | .25 – .40" | | | |
| Indicating instrument (included in package) | 2034201 µMaxµm II | | 2033109 Maxµm III | 2033119 Maxµm III | 2033109 Maxµm III | 2033119 Maxµm III |

ACCESSORIES

| Order no. | Description | Type |
|-----------|---|--------|
| 2220455 | Jaw set of measuring elements, with measuring anvils made of carbide | JW-58 |
| 2225702 | Measuring anvil for JW-9, made of steel | PS-55 |
| 2225676 | Separate measuring anvils for JW-58 / 2003211 measuring elements, made of carbide | PS-226 |

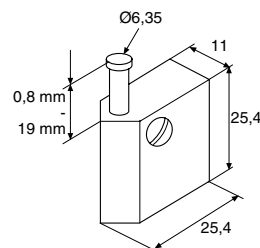

JW-9; JW-58;
JW-69

Multimar 36B-10 / 36B-20

Indicator gage

FEATURES

- Friction-free, zero-backlash measuring anvil holder for high measuring accuracy
- Parallel spring-loaded system for repeatable measuring force
- User-friendly and ergonomic:
 - Table surface can be tilted and clamped between 0° and 90°
 - Adjustable lifting of movable probe
- Adjustable measuring force
- **Data interface:** none
- **Package contains:** set of jaws JW-9, instruction manual

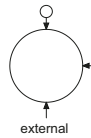
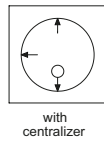
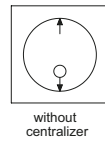

Applications:

- For measuring internal and external diameters, centering edges, narrow shoulders and recesses
- "T"-plates give a diameter reading directly across the diameter
- A third contact may be used as a side-stop or centralizer



TECHNICAL DATA

| Order no. | | 2050643 | 2050647 |
|---|------|----------------------------|-------------|
| Type | | 36B-10 | 36B-20 |
| Application range, outside | inch | .25 – 5" | .25 – 8.75" |
| Application range, inside | inch | .75 – 3.5" | .75 – 7.75" |
| Measuring force, adjustable | N | 0 – 35 | |
| Probe path, adjustable | inch | .25 – .40" | |
| Indicating instrument (included in package) | | 2011593 indicator (32I-RC) | |

ACCESSORIES

| Order no. | Description | Type |
|-----------|---|--------|
| 2220455 | Jaw set of measuring elements, with measuring anvils made of carbide | JW-58 |
| 2225702 | Measuring anvil for JW-9, made of steel | PS-55 |
| 2225676 | Separate measuring anvils for JW-58 / 2003211 measuring elements, made of carbide | PS-226 |

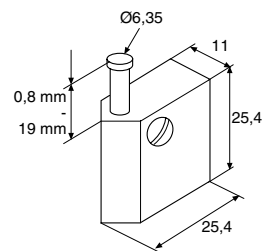

JW-9; JW-58;
JW-69



FEATURES

- Friction-free, zero-backlash measuring anvil holder for high measuring accuracy
- Parallel spring-loaded system for repeatable measuring force
- User-friendly and ergonomic:
 - Table surface can be tilted and clamped between 0° and 90°
 - Adjustable lifting of movable probe
- Adjustable measuring force
- **Data interface:** Digimatic, RS–232C, USB, wireless
- **Energy supply:** battery operation
- **Package contains:** set of jaws JW–9, instruction manual

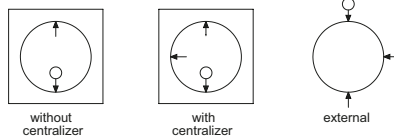

Applications:

- For measuring internal and external diameters, centering edges, narrow shoulders and recesses
- “T”-plates give a diameter reading directly across the diameter. A third contact may be used as a side-stop or centralizer
- “V”-plates are self-centralizing
- Three jaws are used and the measurement is of the distance between the sensitive contact and the chord formed by the two reference contacts. This measurement bears a direct relationship to the diameter and compensation is made by a special ratio indicator so diameter is read directly
- Used to inspect parts with odd number lobing conditions



TECHNICAL DATA

| Order no. | 2061657 | | 2061658 | |
|---|-------------------|----------|-----------|--|
| Type | 36B–10-VT | | 36B–20-VT | |
| Application range, outside | mm | 6–127 | 6–222 | |
| Application range, inside | mm | 19–89 | 19–197 | |
| Measuring force, adjustable | N | 0–35 | | |
| Probe path, adjustable | mm | 6–10 mm | | |
| Probe path, adjustable | inch | .25–.40" | | |
| Indicating instrument (included in package) | 4337662 (1087 BR) | | | |

| Order no. | Mounting hole |
|-----------|---------------|
| | mm |
| 2061657 | 8 |
| 2061658 | 8 |

ACCESSORIES

| Order no. | Description | Type |
|-----------|---|--------|
| 2220455 | Jaw set of measuring elements, with measuring anvils made of carbide | JW–58 |
| 2225702 | Measuring anvil for JW–9, made of steel | PS–55 |
| 2225676 | Separate measuring anvils for JW–58 / 2003211 measuring elements, made of carbide | PS–226 |

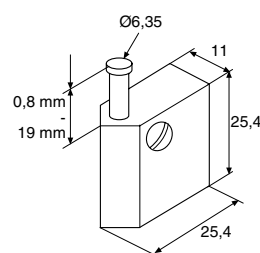

JW–9; JW–58;
JW–69

Multimar EDI-36B-19 / EDI-36B-9 / EMD-36B-19D / EMD-36B-9D

Indicator gage



FEATURES

- Friction-free, zero-backlash measuring anvil holder for high measuring accuracy
- Parallel spring-loaded system for repeatable measuring force
- User-friendly and ergonomic:
 - Table surface can be tilted and clamped between 0° and 90°
 - Adjustable lifting of movable probe
- Adjustable measuring force
- **Data interface:** Digimatic, RS-232C, USB
- **Energy supply:** battery operation
- **Package contains:** set of jaws JW-9, instruction manual

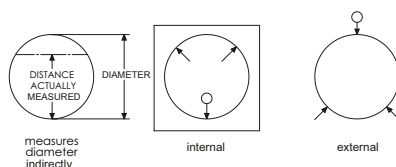

Applications:

- For measuring internal and external diameters, centering edges, narrow shoulders and recesses
- "V"-plates are self-centralizing
- Three jaws are used and the measurement is of the distance between the sensitive contact and the chord formed by the two reference contacts. This measurement bears a direct relationship to the diameter and compensation is made by a special ratio indicator so diameter is read directly
- Used to inspect parts with odd number lobing conditions



TECHNICAL DATA

| Order no. | | 2051694 | 2051696 | 2051871 | 2051881 |
|---|------|------------------------------|---------------|--------------------------------------|---------------|
| Type | | EDI-36B-19 | EDI-36B-9 | EMD-36B-19D | EMD-36B-9D |
| Application range outside | mm | 8 – 241 | 8 – 127 | 8 – 241 | 8 – 127 |
| Application range, outside | inch | .312 – 9.5" | .312 – 5" | .312 – 9.5" | .312 – 5" |
| Application range inside | mm | 21 – 229 | 21 – 117 | 21 – 229 | 21 – 117 |
| Application range, inside | inch | .812 – 9" | .812 – 4.625" | .812 – 9" | .812 – 4.625" |
| Measuring force, adjustable | N | 0 – 35 | | | |
| Probe path, adjustable | mm | 6 – 10 mm | | | |
| Probe path, adjustable | inch | .25 – .40" | | | |
| Indicating instrument (included in package) | | 2034201 μ Max μ m II | | 2033145 MaxumIII (special 4:5 ratio) | |

ACCESSORIES

| Order no. | Description | Type |
|-----------|---|--------|
| 2220455 | Jaw set of measuring elements, with measuring anvils made of carbide | JW-58 |
| 2225702 | Measuring anvil for JW-9, made of steel | PS-55 |
| 2225676 | Separate measuring anvils for JW-58 / 2003211 measuring elements, made of carbide | PS-226 |

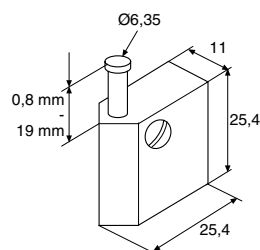

JW-9; JW-58;
JW-69

Multimar 36B-19 / 36B-9

Indicator gage

FEATURES

- Friction-free, zero-backlash measuring anvil holder for high measuring accuracy
- Parallel spring-loaded system for repeatable measuring force
- User-friendly and ergonomic:
 - Table surface can be tilted and clamped between 0° and 90°
 - Adjustable lifting of movable probe
- Adjustable measuring force
- **Data interface:** none
- **Package contains:** set of jaws JW-9, instruction manual

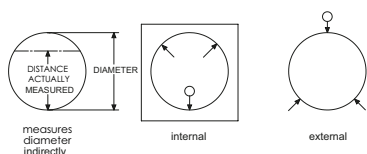

Application:

- For measuring internal and external diameters, centering edges, narrow shoulders and recesses



TECHNICAL DATA

| Order no. | | 2050645 | 2050652 |
|---|------|----------------------------|---------------|
| Type | | 36B-19 | 36B-9 |
| Application range, outside | inch | .312 – 9.5" | .312 – 5" |
| Application range, inside | inch | .812 – 9" | .812 – 4.625" |
| Measuring force, adjustable | N | 0 – 35 | |
| Probe path, adjustable | inch | .25 – .40" | |
| Indicating instrument (included in package) | | IDT-188 indicator (32K-RC) | |

ACCESSORIES

| Order no. | Description | Type |
|-----------|---|--------|
| 2220455 | Jaw set of measuring elements, with measuring anvils made of carbide | JW-58 |
| 2225702 | Measuring anvil for JW-9, made of steel | PS-55 |
| 2225676 | Separate measuring anvils for JW-58 / 2003211 measuring elements, made of carbide | PS-226 |

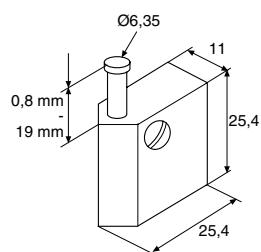

JW-9; JW-58;
JW-69

Multimar 36B–19M / 36B–9M

Indicator gage

FEATURES

- Friction-free, zero-backlash measuring anvil holder for high measuring accuracy
- Parallel spring-loaded system for repeatable measuring force
- User-friendly and ergonomic:
 - Table surface can be tilted and clamped between 0° and 90°
 - Adjustable lifting of movable probe
- Adjustable measuring force
- **Data interface:** none
- **Package contains:** set of jaws JW–9, instruction manual

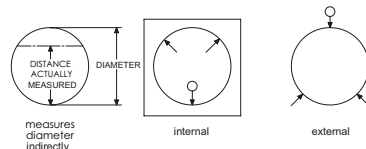

Application:

- For measuring internal and external diameters, centering edges, narrow shoulders and recesses



TECHNICAL DATA

| Order no. | 2050646 | 2050653 |
|---|----------------------------|----------|
| Type | 36B–19M | 36B–9M |
| Application range, outside | mm 8 –241 | 8 –127 |
| Application range, inside | mm 21 –229 | 21 –117 |
| Measuring force, adjustable | N | 0 –35 |
| Probe path, adjustable | mm | 6 –10 mm |
| Indicating instrument (included in package) | IDS–318 indicator (Q21-RC) | |

ACCESSORIES

| Order no. | Description | Type |
|-----------|---|--------|
| 2220455 | Jaw set of measuring elements, with measuring anvils made of carbide | JW–58 |
| 2225702 | Measuring anvil for JW–9, made of steel | PS–55 |
| 2225676 | Separate measuring anvils for JW–58 / 2003211 measuring elements, made of carbide | PS–226 |

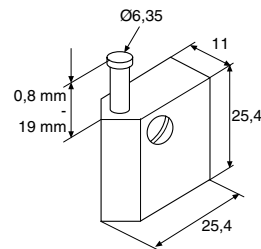

JW–9; JW–58;
JW–69

MarGage | Standards and gage blocks

Today, measurement standards such as parallel gage blocks still form the basis of dimensional metrology. Their applications range from setting gages for indicating measuring instruments to reference standards in calibration laboratories. We guarantee the highest possible quality due to careful selection of materials used and accreditation of the PTB.



Gage blocks

MarGage 402 / 404 / 405 / 406 / 408 / 409 / 412 / 413 **442**
Parallel gage block sets, steel

MarGage 411 / 415 **447**
Parallel gage block sets, steel, for caliper calibration

MarGage 402 C / 404 C / 405 C / 406 C / 408 C / 409 C **448**
Parallel gage block sets, ceramic

MarGage 418 C / 419 C **451**
Parallel gage block sets, ceramic, protective gage blocks and gage blocks for micrometer calibration

MarGage 417 **453**
Parallel gage blocks, individual, steel

MarGage 417 C **456**
Parallel gage blocks, individual, ceramic

Accessories for parallel gage blocks **459**

MarGage 421 **461**
Optical flats, plane-parallel inspection windows

Pin gages

MarGage 426 A **464**
Thread pin gages

MarGage 426 M / 426 MS **465**
Thread pin gages in holder

Setting standards

MarGage 355 E **467**
Setting rings

MarGage 390 **470**
Setting disks

MarGage 402 / 404

Rectangular gage block set made of steel

FEATURES

- Vertical arrangement to save space

Calibration class K

As primary factory standard, particularly for the calibration of subsidiary test laboratories, e.g. for gage blocks of lower tolerance classes.

Tolerance class 0

For maximum accuracy requirements. To be used as basic standards in test laboratories and precision inspection rooms, where other gage blocks and high accuracy measuring instruments are calibrated.

Tolerance class 1

For high accuracy requirements. As reference gage block for the measuring room. Designed to perform particularly accurate measurements. For setting indicating measuring instruments. For checking precision gages.

Tolerance class 2

For checking production gages of quality IT 6 and IT 7. For setting indicating measuring instruments and for checking accurate dimensions in the jig and tool industry.

- Package contains: wooden case with clear labeling strips, Mahr calibration certificate

- Coefficient of linear expansion: $11.5 \times 10^{-6} \text{ K}^{-1}$



TECHNICAL DATA

| Order no. | Type | Quantity per set | Tolerance class | Nominal sizes | Increment | Number |
|------------|------|------------------|-----------------|--|-----------|--------|
| | | | | mm | mm | |
| 4800400 | 402 | 32 | 0 | 1.005 | - | 1 |
| | | | | 1.01 – 1.09 | 0.01 | 9 |
| | | | | 1.1 – 1.9 | 0.1 | 9 |
| | | | | 1 – 9 | 1 | 9 |
| | | | | 10 – 30 | 10 | 3 |
| | | | | 50 | - | 1 |
| 4800401 | 402 | 32 | 1 | 1.005 | - | 1 |
| | | | | 1.01 – 1.09 | 0.01 | 9 |
| | | | | 1.1 – 1.9 | 0.1 | 9 |
| | | | | 1 – 9 | 1 | 9 |
| | | | | 10 – 30 | 10 | 3 |
| | | | | 50 | - | 1 |
| 4800402 | 402 | 32 | 2 | 1.005 | - | 1 |
| | | | | 1.01 – 1.09 | 0.01 | 9 |
| | | | | 1.1 – 1.9 | 0.1 | 9 |
| | | | | 1 – 9 | 1 | 9 |
| | | | | 10 – 30 | 10 | 3 |
| | | | | 50 | - | 1 |
| 4800403DKS | 402 | 32 | K | 1.005 | - | 1 |
| | | | | 1.01 – 1.09 | 0.01 | 9 |
| | | | | 1.1 – 1.9 | 0.1 | 9 |
| | | | | 1 – 9 | 1 | 9 |
| | | | | 10 – 30 | 10 | 3 |
| | | | | 50 | - | 1 |
| 4800000 | 404 | 46 | 0 | 1.001 – 1.009 | 0.001 | 9 |
| | | | | 1.01 – 1.09 | 0.01 | 9 |
| | | | | 1.1 – 1.9 | 0.1 | 9 |
| | | | | 1 – 9 | 1 | 9 |
| | | | | 10 – 100 | 10 | 10 |
| | | | | Includes Mahr calibration certificate | | |
| 4800001 | 404 | 46 | 1 | 1.001 – 1.009 | 0.001 | 9 |
| | | | | 1.01 – 1.09 | 0.01 | 9 |
| | | | | 1.1 – 1.9 | 0.1 | 9 |
| | | | | 1 – 9 | 1 | 9 |
| | | | | 10 – 100 | 10 | 10 |
| | | | | Includes Mahr calibration certificate | | |
| 4800002 | 404 | 46 | 2 | 1.001 – 1.009 | 0.001 | 9 |
| | | | | 1.01 – 1.09 | 0.01 | 9 |
| | | | | 1.1 – 1.9 | 0.1 | 9 |
| | | | | 1 – 9 | 1 | 9 |
| | | | | 10 – 100 | 10 | 10 |
| | | | | Includes Mahr calibration certificate | | |
| 4800003DKS | 404 | 46 | K | 1.001 – 1.009 | 0.001 | 9 |
| | | | | 1.01 – 1.09 | 0.01 | 9 |
| | | | | 1.1 – 1.9 | 0.1 | 9 |
| | | | | 1 – 9 | 1 | 9 |
| | | | | 10 – 100 | 10 | 10 |
| | | | | Includes DAkKS calibration certificate | | |



424

ACCESSORIES

| Order no. | Description | Type |
|-----------|--|------|
| 4800130 | Gage block maintenance accessories | 424 |
| 4800140 | Optical flat, $\varnothing = 45 \text{ mm}$ | 421 |
| 4800142 | Wooden tongs, single, to prevent heat transfer when handling gage blocks | 423 |

MarGage 405 / 406

Rectangular gage block set made of steel

FEATURES

- Vertical arrangement to save space

Calibration class K

As primary factory standard, particularly for the calibration of subsidiary test laboratories, e.g. for gage blocks of lower tolerance classes.

Tolerance class 0

For maximum accuracy requirements. To be used as basic standards in test laboratories and precision inspection rooms, where other gage blocks and high accuracy measuring instruments are calibrated.

Tolerance class 1

For high accuracy requirements. As reference gage block for the measuring room. Designed to perform particularly accurate measurements. For setting indicating measuring instruments. For checking precision gages.

Tolerance class 2

For checking production gages of quality IT 6 and IT 7. For setting indicating measuring instruments and for checking accurate dimensions in the jig and tool industry.

- Package contains: wooden case with clear labeling strips, Mahr calibration certificate
- Coefficient of linear expansion: $11.5 \times 10^{-6} \text{ K}^{-1}$



TECHNICAL DATA

| Order no. | Type | Quantity per set | Tolerance class | Nominal sizes | Increment | Number |
|------------|------|------------------|-----------------|---------------|-----------|--------|
| | | Pieces | | mm | mm | |
| 4800410 | 405 | 47 | 0 | 1.005 | - | 1 |
| | | | | 1.01 – 1.19 | 0.01 | 19 |
| | | | | 1.2 – 1.9 | 0.1 | 8 |
| | | | | 1 – 9 | 1 | 9 |
| | | | | 10 – 100 | 10 | 10 |
| 4800411 | 405 | 47 | 1 | 1.005 | - | 1 |
| | | | | 1.01 – 1.19 | 0.01 | 19 |
| | | | | 1.2 – 1.9 | 0.1 | 8 |
| | | | | 1 – 9 | 1 | 9 |
| | | | | 10 – 100 | 10 | 10 |
| 4800412 | 405 | 47 | 2 | 1.005 | - | 1 |
| | | | | 1.01 – 1.19 | 0.01 | 19 |
| | | | | 1.2 – 1.9 | 0.1 | 8 |
| | | | | 1 – 9 | 1 | 9 |
| | | | | 10 – 100 | 10 | 10 |
| 4800413DKS | 405 | 47 | K | 1.005 | - | 1 |
| | | | | 1.01 – 1.19 | 0.01 | 19 |
| | | | | 1.2 – 1.9 | 0.1 | 8 |
| | | | | 1 – 9 | 1 | 9 |
| | | | | 10 – 100 | 10 | 10 |
| 4800010 | 406 | 87 | 0 | 0.5 | - | 1 |
| | | | | 1.001 – 1.009 | 0.001 | 9 |
| | | | | 1.01 – 1.49 | 0.01 | 49 |
| | | | | 1 – 9.5 | 0.5 | 18 |
| | | | | 10 – 100 | 10 | 10 |
| 4800011 | 406 | 87 | 1 | 0.5 | - | 1 |
| | | | | 1.001 – 1.009 | 0.001 | 9 |
| | | | | 1.01 – 1.49 | 0.01 | 49 |
| | | | | 1 – 9.5 | 0.5 | 18 |
| | | | | 10 – 100 | 10 | 10 |
| 4800012 | 406 | 87 | 2 | 0.5 | - | 1 |
| | | | | 1.001 – 1.009 | 0.001 | 9 |
| | | | | 1.01 – 1.49 | 0.01 | 49 |
| | | | | 1 – 9.5 | 0.5 | 18 |
| | | | | 10 – 100 | 10 | 10 |
| 4800014DKS | 406 | 87 | K | 0.5 | - | 1 |
| | | | | 1.001 – 1.009 | 0.001 | 9 |
| | | | | 1.01 – 1.49 | 0.01 | 49 |
| | | | | 1 – 9.5 | 0.5 | 18 |
| | | | | 10 – 100 | 10 | 10 |



ACCESSORIES

| Order no. | Description | Type |
|-----------|--|------|
| 4800130 | Gage block maintenance accessories | 424 |
| 4800140 | Optical flat, $\varnothing = 45 \text{ mm}$ | 421 |
| 4800142 | Wooden tongs, single, to prevent heat transfer when handling gage blocks | 423 |

MarGage 408 / 409

Rectangular gage block set made of steel

FEATURES

- Vertical arrangement to save space

Calibration class K

As primary factory standard, particularly for the calibration of subsidiary test laboratories, e.g. for gage blocks of lower tolerance classes.

Tolerance class 0

For maximum accuracy requirements. To be used as basic standards in test laboratories and precision inspection rooms, where other gage blocks and high accuracy measuring instruments are calibrated.

Tolerance class 1

For high accuracy requirements. As reference gage block for the measuring room. Designed to perform particularly accurate measurements. For setting indicating measuring instruments. For checking precision gages.

Tolerance class 2

For checking production gages of quality IT 6 and IT 7. For setting indicating measuring instruments and for checking accurate dimensions in the jig and tool industry.

- Package contains: wooden case with clear labeling strips, Mahr calibration certificate
- Coefficient of linear expansion: $11.5 \times 10^{-6} \text{ K}^{-1}$



TECHNICAL DATA

| Order no. | Type | Quantity per set | Tolerance class | Nominal sizes | | Number |
|-----------------|------|------------------|-----------------|-----------------|-------|--------|
| | | | | mm | mm | |
| 4800020 | 408 | 111 | 0 | 0.5 | - | 1 |
| | | | | 1.001–1.009 | 0.001 | 9 |
| | | | | 1.01–1.49 | 0.01 | 49 |
| | | | | 1–24.5 | 0.5 | 48 |
| | | | | 25–100 | 25 | 4 |
| 4800021 | 408 | 111 | 1 | 0.5 | - | 1 |
| | | | | 1.001–1.009 | 0.001 | 9 |
| | | | | 1.01–1.49 | 0.01 | 49 |
| | | | | 1–24.5 | 0.5 | 48 |
| | | | | 25–100 | 25 | 4 |
| 4800022 | 408 | 111 | 2 | 0.5 | - | 1 |
| | | | | 1.001–1.009 | 0.001 | 9 |
| | | | | 1.01–1.49 | 0.01 | 49 |
| | | | | 1–24.5 | 0.5 | 48 |
| | | | | 25–100 | 25 | 4 |
| 4800027DKS | 408 | 111 | K | 0.5 | - | 1 |
| | | | | 1.001–1.009 | 0.001 | 9 |
| | | | | 1.01–1.49 | 0.01 | 49 |
| | | | | 1–24.5 | 0.5 | 48 |
| | | | | 25–100 | 25 | 4 |
| 4800030 | 409 | 121 | 0 | 0.5 | - | 1 |
| | | | | 1.001–1.009 | 0.001 | 9 |
| | | | | 1.01–1.49 | 0.01 | 49 |
| | | | | 1.6–1.9 | 0.1 | 4 |
| | | | | 1–24.5 | 0.5 | 48 |
| | | | | 30. 40. 60. 70 | 10 | 6 |
| | | | | .80 .90 | 25 | 4 |
| | | | | 25. 50. 75. 100 | - | - |
| | | | | 0.5 | - | 1 |
| | | | | 1.001–1.009 | 0.001 | 9 |
| 1.01–1.49 | 0.01 | 49 | | | | |
| 1.6–1.9 | 0.1 | 4 | | | | |
| 1–24.5 | 0.5 | 48 | | | | |
| 30. 40. 60. 70 | 10 | 6 | | | | |
| .80 .90 | 25 | 4 | | | | |
| 25. 50. 75. 100 | - | - | | | | |
| 4800031 | 409 | 121 | 1 | 0.5 | - | 1 |
| | | | | 1.001–1.009 | 0.001 | 9 |
| | | | | 1.01–1.49 | 0.01 | 49 |
| | | | | 1.6–1.9 | 0.1 | 4 |
| | | | | 1–24.5 | 0.5 | 48 |
| | | | | 30. 40. 60. 70 | 10 | 6 |
| | | | | .80 .90 | 25 | 4 |
| | | | | 25. 50. 75. 100 | - | - |
| | | | | 0.5 | - | 1 |
| | | | | 1.001–1.009 | 0.001 | 9 |
| 1.01–1.49 | 0.01 | 49 | | | | |
| 1.6–1.9 | 0.1 | 4 | | | | |
| 1–24.5 | 0.5 | 48 | | | | |
| 30. 40. 60. 70 | 10 | 6 | | | | |
| .80 .90 | 25 | 4 | | | | |
| 25. 50. 75. 100 | - | - | | | | |
| 4800032 | 409 | 121 | 2 | 0.5 | - | 1 |
| | | | | 1.001–1.009 | 0.001 | 9 |
| | | | | 1.01–1.49 | 0.01 | 49 |
| | | | | 1.6–1.9 | 0.1 | 4 |
| | | | | 1–24.5 | 0.5 | 48 |
| | | | | 30. 40. 60. 70 | 10 | 6 |
| | | | | .80 .90 | 25 | 4 |
| | | | | 25. 50. 75. 100 | - | - |
| | | | | 0.5 | - | 1 |
| | | | | 1.001–1.009 | 0.001 | 9 |
| 1.01–1.49 | 0.01 | 49 | | | | |
| 1.6–1.9 | 0.1 | 4 | | | | |
| 1–24.5 | 0.5 | 48 | | | | |
| 30. 40. 60. 70 | 10 | 6 | | | | |
| .80 .90 | 25 | 4 | | | | |
| 25. 50. 75. 100 | - | - | | | | |
| 4800033DKS | 409 | 121 | K | 0.5 | - | 1 |
| | | | | 1.001–1.009 | 0.001 | 9 |
| | | | | 1.01–1.49 | 0.01 | 49 |
| | | | | 1.6–1.9 | 0.1 | 4 |
| | | | | 1–24.5 | 0.5 | 48 |
| | | | | 30. 40. 60. 70 | 10 | 6 |
| | | | | .80 .90 | 25 | 4 |
| | | | | 25. 50. 75. 100 | - | - |
| | | | | 0.5 | - | 1 |
| | | | | 1.001–1.009 | 0.001 | 9 |
| 1.01–1.49 | 0.01 | 49 | | | | |
| 1.6–1.9 | 0.1 | 4 | | | | |
| 1–24.5 | 0.5 | 48 | | | | |
| 30. 40. 60. 70 | 10 | 6 | | | | |
| .80 .90 | 25 | 4 | | | | |
| 25. 50. 75. 100 | - | - | | | | |



423



424

ACCESSORIES

| Order no. | Description | Type |
|-----------|--|------|
| 4800130 | Gage block maintenance accessories | 424 |
| 4800140 | Optical flat, $\varnothing = 45 \text{ mm}$ | 421 |
| 4800142 | Wooden tongs, single, to prevent heat transfer when handling gage blocks | 423 |

MarGage

Rectangular gage block set made of steel

FEATURES

- Long used as the practical standards of dimensional measurement in precision manufacturing
- With accuracies, materials and manufacturing methods greatly refined, gage blocks are now of highest quality and precision
- Used as comparison reference and utilization standards in the field of length measurement
- For checking gages and measuring instruments
- Used individually or in combinations by wringing several blocks together
- Mahr gage blocks are available from stock individually and as full sets in inches (rectangular only)
- Sets are manufactured to Grade 0 only, which meet or exceed ASME B89.1.9–2002 specifications
- Offered in steel to suit a wide range of service conditions
 - Steel blocks are extremely stable, hardened to Rc 62 minimum, and processed through a thorough seasoning cycle to relieve internal stresses before lap finishing
- All block sets are serialized and supplied in a fitted storage case (certification priced separately)
- **Package contains:** wooden case with clear labeling strips



TECHNICAL DATA

| Order no. | Quantity per set | Tolerance class | Nominal sizes | Increment | Number |
|-----------|------------------|---------------------------------------|---|--|-----------------------|
| | Pieces | | inch | inch | |
| 2176361 | 81 | 0 | .1001" – .1009" .101" – .149" .050" – .950" | .0001" .001" .050" | 9 49 19 |
| | | Includes Mahr calibration certificate | 1.000" – 4.000" | 1.00" | 4 |
| 2176362 | 49 | 0 | .1001" – .1009" .101" – .109" .010" – .090" .110" – .190" .100" – .900" | .0001" .001" .010" .010" .100" | 9 9 9 9 9 |
| | | Includes Mahr calibration certificate | 1.000" – 4.000" | 1.00" | 4 |

ACCESSORIES

| Order no. | Description | Type |
|-----------|--|------|
| 4800130 | Gage block maintenance accessories | 424 |
| 4800140 | Optical flat, Ø = 45 mm | 421 |
| 4800142 | Wooden tongs, single, to prevent heat transfer when handling gage blocks | 423 |

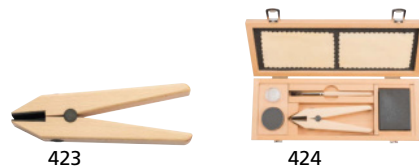

MarGage 412 / 413

Rectangular gage block set made of steel

FEATURES

- Vertical arrangement to save space

Calibration class K

As primary factory standard, particularly for the calibration of subsidiary test laboratories, e.g. for gage blocks of lower tolerance classes.

Tolerance class 0

For maximum accuracy requirements. To be used as basic standards in test laboratories and precision inspection rooms, where other gage blocks and high accuracy measuring instruments are calibrated.

Tolerance class 1

For high accuracy requirements. As reference gage block for the measuring room. Designed to perform particularly accurate measurements. For setting indicating measuring instruments. For checking precision gages.

Tolerance class 2

For checking production gages of quality IT 6 and IT 7. For setting indicating measuring instruments and for checking accurate dimensions in the jig and tool industry.

- Package contains: wooden case with clear labeling strips, Mahr calibration certificate
- Coefficient of linear expansion: $11.5 \times 10^{-6} \text{ K}^{-1}$



TECHNICAL DATA

| Order no. | Type | Quantity per set | Tolerance class | Nominal sizes | Number |
|------------|------|------------------|--|---|--------|
| | | Pieces | | mm | |
| 4800425 | 412 | 8 | 0 | 125 / 150 / 175 / 200 / 250 / 300 / 400 / 500 | 8 |
| | | | Includes Mahr calibration certificate | | |
| 4800426 | 412 | 8 | 1 | 125 / 150 / 175 / 200 / 250 / 300 / 400 / 500 | 8 |
| | | | Includes Mahr calibration certificate | | |
| 4800427 | 412 | 8 | 2 | 125 / 150 / 175 / 200 / 250 / 300 / 400 / 500 | 8 |
| | | | Includes Mahr calibration certificate | | |
| 4800428DKS | 412 | 8 | K | 125 / 150 / 175 / 200 / 250 / 300 / 400 / 500 | 8 |
| | | | Includes DAkks calibration certificate | | |
| 4800430 | 413 | 5 | 0 | 600 / 700 / 800 / 900 / 1000 | 5 |
| | | | Includes Mahr calibration certificate | | |
| 4800431 | 413 | 5 | 1 | 600 / 700 / 800 / 900 / 1000 | 5 |
| | | | Includes Mahr calibration certificate | | |
| 4800432 | 413 | 5 | 2 | 600 / 700 / 800 / 900 / 1000 | 5 |
| | | | Includes Mahr calibration certificate | | |
| 4800433DKS | 413 | 5 | K | 600 / 700 / 800 / 900 / 1000 | 8 |
| | | | Includes DAkks calibration certificate | | |

ACCESSORIES

| Order no. | Description | Type |
|-----------|--|-------|
| 4800140 | Optical flat, $\varnothing = 45 \text{ mm}$ | 421 |
| 4800180 | Optical parallel, $\varnothing = 30 \text{ mm}$ | 421 P |
| 4800142 | Wooden tongs, single, to prevent heat transfer when handling gage blocks | 423 |
| 4800130 | Gage block maintenance accessories | 424 |

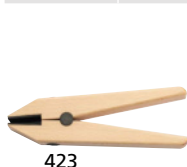

MarGage 411 / 415

Rectangular gage block set made of steel

FEATURES

- Vertical arrangement to save space

Tolerance class 1

For high accuracy requirements. As reference gage block for the measuring room. Designed to perform particularly accurate measurements. For setting indicating measuring instruments. For checking precision gages.

- **Package contains:** wooden case with clear labeling strips, Mahr calibration certificate
- **Coefficient of linear expansion:** $11.5 \times 10^{-6} \text{ K}^{-1}$



Application:

- For testing and calibrating calipers



TECHNICAL DATA

| Order no. | Type | Quantity per set | Tolerance class | Nominal sizes | Number |
|-----------|------|------------------|--|---|--------|
| | | Pieces | | mm | |
| 4800343 | 411 | 5 | 1 Includes Mahr calibration certificate | 30 / 41.3 / 131.4 / 243.5 / 281.2 | 5 |
| 4800344 | 411 | 5 | 2 Includes Mahr calibration certificate | 30 / 41.3 / 131.4 / 243.5 / 281.2 | 5 |
| 4800339 | 415 | 6 | 1 Includes Mahr calibration certificate | 30 / 41.3 / 131.4 / 243.5 / 281.2 / 481.1 | 6 |
| 4800340 | 415 | 6 | 2 Includes Mahr calibration certificate | 30 / 41.3 / 131.4 / 243.5 / 281.2 / 481.1 | 6 |

MarGage 402 C / 404 C

Rectangular gage block set made of ceramic

FEATURES

- For use in metrology rooms as well as harsh workshop environments
- Practical properties: easy to slide, corrosion-free, no need to preserve, lightweight and very scratch-resistant
- **Corrosion-resistant:** ceramic is also highly resistant to lyes, acids, oil, grinding water and other aggressive media
- Damage to measuring surfaces from scratches or outbreaks causes no burring. The slide function and dimensional stability are retained
- **Extremely wear-resistant:** he longest idle periods and highest stability of all gage block materials. Allows for significantly longer gage monitoring intervals
- **Coefficient of expansion similar to that of steel:** therefore there are no usage restrictions, in manufacturing or in the laboratory, even in extreme temperature conditions
- Ceramic is antistatic, anti-magnetic and not electrically conductive

Calibration class K

As primary factory standard, particularly for the calibration of subsidiary test laboratories, e.g. for gage blocks of lower tolerance classes.

Tolerance class 0

For maximum accuracy requirements. To be used as basic standards in test laboratories and precision inspection rooms, where other gage blocks and high accuracy measuring instruments are calibrated.

Tolerance class 1

For high accuracy requirements. As reference gage block for the measuring room. Designed to perform particularly accurate measurements. For setting indicating measuring instruments. For checking precision gages.

Tolerance class 2

For checking production gages of quality IT 6 and IT 7. For setting indicating measuring instruments and for checking accurate dimensions in the jig and tool industry.

- **Package contains:** wooden case with clear labeling strips, Mahr calibration certificate

- **Coefficient of linear expansion:** $9.3 \times 10^{-6} \text{ K}^{-1}$



TECHNICAL DATA

| Order no. | Type | Quantity per set | Tolerance class | Nominal sizes | Increment | Number |
|------------|-------|------------------|-----------------|---------------|-----------|--------|
| | | | | mm | mm | |
| 4800095 | 402 C | 32 | 0 | 1.005 | - | 1 |
| | | | | 1.01 – 1.09 | 0.01 | 9 |
| | | | | 1.1 – 1.9 | 0.1 | 9 |
| | | | | 1 – 9 | 1 | 9 |
| | | | | 10 – 30 | 10 | 3 |
| 50 | - | 1 | | | | |
| 4800096 | 402 C | 32 | 1 | 1.005 | - | 1 |
| | | | | 1.01 – 1.09 | 0.01 | 9 |
| | | | | 1.1 – 1.9 | 0.1 | 9 |
| | | | | 1 – 9 | 1 | 9 |
| | | | | 10 – 30 | 10 | 3 |
| 50 | - | 1 | | | | |
| 4800097 | 402 C | 32 | 2 | 1.005 | - | 1 |
| | | | | 1.01 – 1.09 | 0.01 | 9 |
| | | | | 1.1 – 1.9 | 0.1 | 9 |
| | | | | 1 – 9 | 1 | 9 |
| | | | | 10 – 30 | 10 | 3 |
| 50 | - | 1 | | | | |
| 4800094DKS | 402 C | 32 | K | 1.005 | - | 1 |
| | | | | 1.01 – 1.09 | 0.01 | 9 |
| | | | | 1.1 – 1.9 | 0.1 | 9 |
| | | | | 1 – 9 | 1 | 9 |
| | | | | 10 – 30 | 10 | 3 |
| 50 | - | 1 | | | | |
| 4800008 | 404 C | 46 | 0 | 1.001 – 1.009 | 0.001 | 9 |
| | | | | 1.01 – 1.09 | 0.01 | 9 |
| | | | | 1.1 – 1.9 | 0.1 | 9 |
| | | | | 1 – 9 | 1 | 9 |
| | | | | 10 – 100 | 10 | 10 |
| 4800009 | 404 C | 46 | 1 | 1.001 – 1.009 | 0.001 | 9 |
| | | | | 1.01 – 1.09 | 0.01 | 9 |
| | | | | 1.1 – 1.9 | 0.1 | 9 |
| | | | | 1 – 9 | 1 | 9 |
| | | | | 10 – 100 | 10 | 10 |
| 4800004 | 404 C | 46 | 2 | 1.001 – 1.009 | 0.001 | 9 |
| | | | | 1.01 – 1.09 | 0.01 | 9 |
| | | | | 1.1 – 1.9 | 0.1 | 9 |
| | | | | 1 – 9 | 1 | 9 |
| | | | | 10 – 100 | 10 | 10 |
| 4800088DKS | 404 C | 46 | K | 1.001 – 1.009 | 0.001 | 9 |
| | | | | 1.01 – 1.09 | 0.01 | 9 |
| | | | | 1.1 – 1.9 | 0.1 | 9 |
| | | | | 1 – 9 | 1 | 9 |
| | | | | 10 – 100 | 10 | 10 |

ACCESSORIES

| Order no. | Description | Type |
|-----------|--|------|
| 4800130 | Gage block maintenance accessories | 424 |
| 4800140 | Optical flat, $\varnothing = 45 \text{ mm}$ | 421 |
| 4800142 | Wooden tongs, single, to prevent heat transfer when handling gage blocks | 423 |



423

424

MarGage 405 C / 406 C

Rectangular gage block set made of ceramic

FEATURES

- For use in metrology rooms as well as harsh workshop environments
- Practical properties: easy to slide, corrosion-free, no need to preserve, lightweight and very scratch-resistant
- **Corrosion-resistant:** ceramic is also highly resistant to lyes, acids, oil, grinding water and other aggressive media
- Damage to measuring surfaces from scratches or outbreaks causes no burring. The slide function and dimensional stability are retained
- **Extremely wear-resistant.** The longest idle periods and highest stability of all gage block materials. Allows for significantly longer gage monitoring intervals
- **Coefficient of expansion similar to that of steel:** therefore there are no usage restrictions, in manufacturing or in the laboratory, even in extreme temperature conditions
- Ceramic is antistatic, anti-magnetic and not electrically conductive

Calibration class K

As primary factory standard, particularly for the calibration of subsidiary test laboratories, e.g. for gage blocks of lower tolerance classes.

Tolerance class 0

For maximum accuracy requirements. To be used as basic standards in test laboratories and precision inspection rooms, where other gage blocks and high accuracy measuring instruments are calibrated.

Tolerance class 1

For high accuracy requirements. As reference gage block for the measuring room. Designed to perform particularly accurate measurements. For setting indicating measuring instruments. For checking precision gages.

Tolerance class 2

For checking production gages of quality IT 6 and IT 7. For setting indicating measuring instruments and for checking accurate dimensions in the jig and tool industry.

- **Package contains:** wooden case with clear labeling strips, Mahr calibration certificate

- **Coefficient of linear expansion:** $9.3 \times 10^{-6} \text{ K}^{-1}$



TECHNICAL DATA

| Order no. | Type | Quantity per set | Tolerance class | Nominal sizes | Increment | Number |
|------------|-------|------------------|-----------------|---------------|-----------|--------|
| | | Pieces | | mm | mm | |
| 4800420 | 405 C | 47 | 0 | 1.005 | - | 1 |
| | | | | 1.01 – 1.19 | 0.01 | 19 |
| | | | | 1.2 – 1.9 | 0.1 | 8 |
| | | | | 1 – 9 | 1 | 9 |
| | | | | 10 – 100 | 10 | 10 |
| 4800421 | 405 C | 47 | 1 | 1.005 | - | 1 |
| | | | | 1.01 – 1.19 | 0.01 | 19 |
| | | | | 1.2 – 1.9 | 0.1 | 8 |
| | | | | 1 – 9 | 1 | 9 |
| | | | | 10 – 100 | 10 | 10 |
| 4800422 | 405 C | 47 | 2 | 1.005 | - | 1 |
| | | | | 1.01 – 1.19 | 0.01 | 19 |
| | | | | 1.2 – 1.9 | 0.1 | 8 |
| | | | | 1 – 9 | 1 | 9 |
| | | | | 10 – 100 | 10 | 10 |
| 4800423DKS | 405 C | 47 | K | 1.005 | - | 1 |
| | | | | 1.01 – 1.19 | 0.01 | 19 |
| | | | | 1.2 – 1.9 | 0.1 | 8 |
| | | | | 1 – 9 | 1 | 9 |
| | | | | 10 – 100 | 10 | 10 |
| 4800018 | 406 C | 87 | 0 | 0.5 | - | 1 |
| | | | | 1.001 – 1.009 | 0.001 | 9 |
| | | | | 1.01 – 1.49 | 0.01 | 49 |
| | | | | 1 – 9.5 | 0.5 | 18 |
| | | | | 10 – 100 | 10 | 10 |
| 4800019 | 406 C | 87 | 1 | 0.5 | - | 1 |
| | | | | 1.001 – 1.009 | 0.001 | 9 |
| | | | | 1.01 – 1.49 | 0.01 | 49 |
| | | | | 1 – 9.5 | 0.5 | 18 |
| | | | | 10 – 100 | 10 | 10 |
| 4800017 | 406 C | 87 | 2 | 0.5 | - | 1 |
| | | | | 1.001 – 1.009 | 0.001 | 9 |
| | | | | 1.01 – 1.49 | 0.01 | 49 |
| | | | | 1 – 9.5 | 0.5 | 18 |
| | | | | 10 – 100 | 10 | 10 |
| 4800416DKS | 406 C | 87 | K | 0.5 | - | 1 |
| | | | | 1.001 – 1.009 | 0.001 | 9 |
| | | | | 1.01 – 1.49 | 0.01 | 49 |
| | | | | 1 – 9.5 | 0.5 | 18 |
| | | | | 10 – 100 | 10 | 10 |

ACCESSORIES

| Order no. | Description | Type |
|-----------|--|------|
| 4800130 | Gage block maintenance accessories | 424 |
| 4800140 | Optical flat, $\varnothing = 45 \text{ mm}$ | 421 |
| 4800142 | Wooden tongs, single, to prevent heat transfer when handling gage blocks | 423 |



423



424

MarGage 408 C / 409 C

Rectangular gage block set made of ceramic

FEATURES

- For use in metrology rooms as well as harsh workshop environments
- Practical properties: easy to slide, corrosion-free, no need to preserve, lightweight and very scratch-resistant
- **Corrosion-resistant:** ceramic is also highly resistant to lyes, acids, oil, grinding water and other aggressive media
- Damage to measuring surfaces from scratches or outbreaks causes no burring. The slide function and dimensional stability are retained
- **Extremely wear-resistant:** the longest idle periods and highest stability of all gage block materials. Allows for significantly longer gage monitoring intervals
- **Coefficient of expansion similar to that of steel:** therefore there are no usage restrictions, in manufacturing or in the laboratory, even in extreme temperature conditions
- Ceramic is antistatic, anti-magnetic and not electrically conductive

Calibration class K

As primary factory standard, particularly for the calibration of subsidiary test laboratories, e.g. for gage blocks of lower tolerance classes.

Tolerance class 0

For maximum accuracy requirements. To be used as basic standards in test laboratories and precision inspection rooms, where other gage blocks and high accuracy measuring instruments are calibrated.

Tolerance class 1

For high accuracy requirements. As reference gage block for the measuring room. Designed to perform particularly accurate measurements. For setting indicating measuring instruments. For checking precision gages.

Tolerance class 2

For checking production gages of quality IT 6 and IT 7. For setting indicating measuring instruments and for checking accurate dimensions in the jig and tool industry.

- **Package contains:** wooden case with clear labeling strips, Mahr calibration certificate

- **Coefficient of linear expansion:** $9.3 \times 10^{-6} \text{ K}^{-1}$



TECHNICAL DATA

| Order no. | Type | Quantity per set | Tolerance class | Nominal sizes | | Number |
|-----------------|-------|------------------|-----------------|----------------|-------|--------|
| | | | | mm | mm | |
| 4800028 | 408 C | 111 | 0 | 0.5 | - | 1 |
| | | | | 1.001 – 1.009 | 0.001 | 9 |
| | | | | 1.01 – 1.49 | 0.01 | 49 |
| | | | | 1 – 24.5 | 0.5 | 48 |
| | | | | 25 – 100 | 25 | 4 |
| 4800029 | 408 C | 111 | 1 | 0.5 | - | 1 |
| | | | | 1.001 – 1.009 | 0.001 | 9 |
| | | | | 1.01 – 1.49 | 0.01 | 49 |
| | | | | 1 – 24.5 | 0.5 | 48 |
| | | | | 25 – 100 | 25 | 4 |
| 4800026 | 408 C | 111 | 2 | 0.5 | - | 1 |
| | | | | 1.001 – 1.009 | 0.001 | 9 |
| | | | | 1.01 – 1.49 | 0.01 | 49 |
| | | | | 1 – 24.5 | 0.5 | 48 |
| | | | | 25 – 100 | 25 | 4 |
| 4800025DKS | 408 C | 111 | K | 0.5 | - | 1 |
| | | | | 1.001 – 1.009 | 0.001 | 9 |
| | | | | 1.01 – 1.49 | 0.01 | 49 |
| | | | | 1 – 24.5 | 0.5 | 48 |
| | | | | 25 – 100 | 25 | 4 |
| 4800038 | 409 C | 121 | 0 | 0.5 | - | 1 |
| | | | | 1.001 – 1.009 | 0.001 | 9 |
| | | | | 1.01 – 1.49 | 0.01 | 49 |
| | | | | 1.6 – 1.9 | 0.1 | 4 |
| | | | | 1 – 24.5 | 0.5 | 48 |
| | | | | 30. 40. 60. 70 | 10 | 6 |
| | | | | .80 .90 | 25 | 4 |
| 25. 50. 75. 100 | | | | | | |
| 4800039 | 409 C | 121 | 1 | 0.5 | - | 1 |
| | | | | 1.001 – 1.009 | 0.001 | 9 |
| | | | | 1.01 – 1.49 | 0.01 | 49 |
| | | | | 1.6 – 1.9 | 0.1 | 4 |
| | | | | 1 – 24.5 | 0.5 | 48 |
| | | | | 30. 40. 60. 70 | 10 | 6 |
| | | | | .80 .90 | 25 | 4 |
| 25. 50. 75. 100 | | | | | | |
| 4800037 | 409 C | 121 | 2 | 0.5 | - | 1 |
| | | | | 1.001 – 1.009 | 0.001 | 9 |
| | | | | 1.01 – 1.49 | 0.01 | 49 |
| | | | | 1.6 – 1.9 | 0.1 | 4 |
| | | | | 1 – 24.5 | 0.5 | 48 |
| | | | | 30. 40. 60. 70 | 10 | 6 |
| | | | | .80 .90 | 25 | 4 |
| 25. 50. 75. 100 | | | | | | |
| 4800036DKS | 409 C | 121 | K | 0.5 | - | 1 |
| | | | | 1.001 – 1.009 | 0.001 | 9 |
| | | | | 1.01 – 1.49 | 0.01 | 49 |
| | | | | 1.6 – 1.9 | 0.1 | 4 |
| | | | | 1 – 24.5 | 0.5 | 48 |
| | | | | 30. 40. 60. 70 | 10 | 6 |
| | | | | .80 .90 | 25 | 4 |
| 25. 50. 75. 100 | | | | | | |

ACCESSORIES

| Order no. | Description | Type |
|-----------|--|------|
| 4800130 | Gage block maintenance accessories | 424 |
| 4800140 | Optical flat, Ø = 45 mm | 421 |
| 4800142 | Wooden tongs, single, to prevent heat transfer when handling gage blocks | 423 |



423



424

MarGage 418 C

Rectangular gage block set made of ceramic

FEATURES

- For use in metrology rooms as well as harsh workshop environments
- Practical properties: easy to slide, corrosion-free, no need to preserve, lightweight and very scratch-resistant
- **Corrosion-resistant:** ceramic is also highly resistant to lyes, acids, oil, grinding water and other aggressive media
- Damage to measuring surfaces from scratches or outbreaks causes no burring. The slide function and dimensional stability are retained
- **Extremely wear-resistant:** the longest idle periods and highest stability of all gage block materials. Allows for significantly longer gage monitoring intervals
- **Coefficient of expansion similar to that of steel:** therefore there are no usage restrictions, in manufacturing or in the laboratory, even in extreme temperature conditions
- Ceramic is antistatic, anti-magnetic and not electrically conductive

Tolerance class 0

For maximum accuracy requirements. To be used as basic standards in test laboratories and precision inspection rooms, where other gage blocks and high accuracy measuring instruments are calibrated.

Tolerance class 1

For high accuracy requirements. As reference gage block for the measuring room. Designed to perform particularly accurate measurements. For setting indicating measuring instruments. For checking precision gages.

- **Package contains:** wooden case with clear labeling strips, Mahr calibration certificate
- **Coefficient of linear expansion:** $9.3 \times 10^{-6} \text{ K}^{-1}$

Application:

- Pair of protective gage blocks: As outer cover gage blocks where the same gage blocks are in frequent use



TECHNICAL DATA

| Order no. | Type | Quantity per set | Tolerance class | Nominal sizes | Number |
|-----------|-------|------------------|---------------------------------------|---------------|--------|
| | | Pieces | | mm | |
| 4800085 | 418 C | 2 | 0 | 2 | 2 |
| | | | Includes Mahr calibration certificate | | |
| 4800086 | 418 C | 2 | 1 | 2 | 2 |
| | | | Includes Mahr calibration certificate | | |

MarGage 419 C

Rectangular gage block set made of ceramic

FEATURES

- For use in metrology rooms as well as harsh workshop environments
 - Practical properties: easy to slide, corrosion-free, no need to preserve, lightweight and very scratch-resistant
 - **Corrosion-resistant:** ceramic is also highly resistant to lyes, acids, oil, grinding water and other aggressive media
 - Damage to measuring surfaces from scratches or outbreaks causes no burring. The slide function and dimensional stability are retained
 - **Extremely wear-resistant:** the longest idle periods and highest stability of all gage block materials. Allows for significantly longer gage monitoring intervals
 - **Coefficient of expansion similar to that of steel:** therefore there are no usage restrictions, in manufacturing or in the laboratory, even in extreme temperature conditions
- Ceramic is antistatic, anti-magnetic and not electrically conductive

Tolerance class 1

For high accuracy requirements. As reference gage block for the measuring room. Designed to perform particularly accurate measurements. For setting indicating measuring instruments. For checking precision gages.

- **Package contains:** wooden case with clear labeling strips, Mahr calibration certificate
- **Coefficient of linear expansion:** $9.3 \times 10^{-6} \text{ K}^{-1}$



Application:

- For testing and calibrating outside micrometers



TECHNICAL DATA

| Order no. | Type | Quantity per set | Tolerance class | Nominal sizes | Number |
|-----------|-------|------------------|--|---|--------|
| | | Pieces | | mm | |
| 4800090 | 419 C | 10 | 1 Includes Mahr calibration certificate | 2.5 / 5.1 / 7.7 / 10.3 / 12.9 / 15.0 / 17.6 / 20.2 / 22.8 / 25 + 421 P, \varnothing 30 mm | 10 |

MarGage 417/0

Rectangular gage blocks made of steel (Tolerance class 0)

FEATURES

- From nominal size 125 mm on, also supplied with wooden case
- Special sizes are available upon request
- Coefficient of linear expansion: $11.5 \times 10^{-6} \text{ K}^{-1}$



| Nominal size mm | Order no. | Nominal size mm | Order no. | Nominal size mm | Order no. |
|-----------------|-----------|-----------------|-----------|-----------------|-----------|
| 0.5 | 4801009 | 1.28 | 4801056 | 12.5 | 4801104 |
| 0.55 | 4801173 | 1.29 | 4801057 | 13 | 4801105 |
| 0.6 | 4801174 | 1.3 | 4801058 | 13.5 | 4801106 |
| 0.65 | 4801175 | 1.31 | 4801059 | 14 | 4801107 |
| 0.7 | 4801176 | 1.32 | 4801060 | 14.5 | 4801108 |
| 0.75 | 4801177 | 1.33 | 4801061 | 15 | 4801109 |
| 0.8 | 4801178 | 1.34 | 4801062 | 15.5 | 4801110 |
| 0.85 | 4801179 | 1.35 | 4801063 | 16 | 4801111 |
| 0.9 | 4801180 | 1.36 | 4801064 | 16.5 | 4801112 |
| 0.95 | 4801181 | 1.37 | 4801065 | 17 | 4801113 |
| 1 | 4801019 | 1.38 | 4801066 | 17.5 | 4801114 |
| 1.0005 | 4801720 | 1.39 | 4801067 | 18 | 4801115 |
| 1.001 | 4801020 | 1.4 | 4801068 | 18.5 | 4801116 |
| 1.002 | 4801021 | 1.41 | 4801069 | 19 | 4801117 |
| 1.003 | 4801022 | 1.42 | 4801070 | 19.5 | 4801118 |
| 1.004 | 4801023 | 1.43 | 4801071 | 20 | 4801119 |
| 1.005 | 4801024 | 1.44 | 4801072 | 20.5 | 4801120 |
| 1.006 | 4801025 | 1.45 | 4801073 | 21 | 4801121 |
| 1.007 | 4801026 | 1.46 | 4801074 | 21.5 | 4801122 |
| 1.008 | 4801027 | 1.47 | 4801075 | 22 | 4801123 |
| 1.009 | 4801028 | 1.48 | 4801076 | 22.5 | 4801124 |
| 1.01 | 4801029 | 1.49 | 4801077 | 23 | 4801125 |
| 1.02 | 4801030 | 1.5 | 4801078 | 23.5 | 4801126 |
| 1.03 | 4801031 | 1.6 | 4801079 | 24 | 4801127 |
| 1.04 | 4801032 | 1.7 | 4801080 | 24.5 | 4801128 |
| 1.05 | 4801033 | 1.8 | 4801081 | 25 | 4801129 |
| 1.06 | 4801034 | 1.9 | 4801082 | 30 | 4801130 |
| 1.07 | 4801035 | 2 | 4801083 | 40 | 4801131 |
| 1.08 | 4801036 | 2.5 | 4801084 | 50 | 4801132 |
| 1.09 | 4801037 | 3 | 4801085 | 60 | 4801133 |
| 1.1 | 4801038 | 3.5 | 4801086 | 70 | 4801134 |
| 1.11 | 4801039 | 4 | 4801087 | 75 | 4801135 |
| 1.12 | 4801040 | 4.5 | 4801088 | 80 | 4801136 |
| 1.13 | 4801041 | 5 | 4801089 | 90 | 4801137 |
| 1.14 | 4801042 | 5.5 | 4801090 | 100 | 4801138 |
| 1.15 | 4801043 | 6 | 4801091 | 125 | 4801139 |
| 1.16 | 4801044 | 6.5 | 4801092 | 150 | 4801140 |
| 1.17 | 4801045 | 7 | 4801093 | 175 | 4801141 |
| 1.18 | 4801046 | 7.5 | 4801094 | 200 | 4801142 |
| 1.19 | 4801047 | 8 | 4801095 | 250 | 4801143 |
| 1.2 | 4801048 | 8.5 | 4801096 | 300 | 4801144 |
| 1.21 | 4801049 | 9 | 4801097 | 400 | 4801146 |
| 1.22 | 4801050 | 9.5 | 4801098 | 500 | 4801148 |
| 1.23 | 4801051 | 10 | 4801099 | 600 | 4801149 |
| 1.24 | 4801052 | 10.5 | 4801100 | 700 | 4801150 |
| 1.25 | 4801053 | 11 | 4801101 | 800 | 4801151 |
| 1.26 | 4801054 | 11.5 | 4801102 | 900 | 4801152 |
| 1.27 | 4801055 | 12 | 4801103 | 1000 | 4801153 |

MarGage 417/1

Rectangular gage blocks made of steel (Tolerance class 1)

FEATURES

- From nominal size 125 mm on, also supplied with wooden case
- Special sizes are available upon request
- Coefficient of linear expansion: $11.5 \times 10^{-6} \text{ K}^{-1}$



| Nominal size mm | Order no. | Nominal size mm | Order no. | Nominal size mm | Order no. |
|-----------------|-----------|-----------------|-----------|-----------------|-----------|
| 0,5 | 4801209 | 1.3 | 4801258 | 14.5 | 4801308 |
| 0.55 | 4801358 | 1.31 | 4801259 | 15 | 4801309 |
| 0.6 | 4801359 | 1.32 | 4801260 | 15.5 | 4801310 |
| 0.65 | 4801360 | 1.33 | 4801261 | 16 | 4801311 |
| 0.7 | 4801361 | 1.34 | 4801262 | 16.5 | 4801312 |
| 0.75 | 4801362 | 1.35 | 4801263 | 17 | 4801313 |
| 0.8 | 4801363 | 1.36 | 4801264 | 17.5 | 4801314 |
| 0.85 | 4801364 | 1.37 | 4801265 | 18 | 4801315 |
| 0.9 | 4801365 | 1.38 | 4801266 | 18.5 | 4801316 |
| 0.95 | 4801366 | 1.39 | 4801267 | 19 | 4801317 |
| 1 | 4801219 | 1.4 | 4801268 | 19.5 | 4801318 |
| 1.0005 | 4801357 | 1.41 | 4801269 | 20 | 4801319 |
| 1.001 | 4801220 | 1.42 | 4801270 | 20.5 | 4801320 |
| 1.002 | 4801221 | 1.43 | 4801271 | 21 | 4801321 |
| 1.003 | 4801222 | 1.44 | 4801272 | 21.5 | 4801322 |
| 1.004 | 4801223 | 1.45 | 4801273 | 22 | 4801323 |
| 1.005 | 4801224 | 1.46 | 4801274 | 22.5 | 4801324 |
| 1.006 | 4801225 | 1.47 | 4801275 | 23 | 4801325 |
| 1.007 | 4801226 | 1.48 | 4801276 | 23.5 | 4801326 |
| 1.008 | 4801227 | 1.49 | 4801277 | 24 | 4801327 |
| 1.009 | 4801228 | 1.5 | 4801278 | 24.5 | 4801328 |
| 1.01 | 4801229 | 1.6 | 4801279 | 25 | 4801329 |
| 1.02 | 4801230 | 1.7 | 4801280 | 30 | 4801330 |
| 1.03 | 4801231 | 1.8 | 4801281 | 40 | 4801331 |
| 1.04 | 4801232 | 1.9 | 4801282 | 131.4 | 4803179 |
| 1.05 | 4801233 | 2 | 4801283 | 50 | 4801332 |
| 1.06 | 4801234 | 2.5 | 4801284 | 60 | 4801333 |
| 1.07 | 4801235 | 3 | 4801285 | 70 | 4801334 |
| 1.08 | 4801236 | 3.5 | 4801286 | 75 | 4801335 |
| 1.09 | 4801237 | 4 | 4801287 | 80 | 4801336 |
| 1.1 | 4801238 | 4.5 | 4801288 | 90 | 4801337 |
| 1.11 | 4801239 | 5 | 4801289 | 100 | 4801338 |
| 1.12 | 4801240 | 5.5 | 4801290 | 125 | 4801339 |
| 1.13 | 4801241 | 6 | 4801291 | 243.5 | 4803180 |
| 1.14 | 4801242 | 6.5 | 4801292 | 150 | 4801340 |
| 1.15 | 4801243 | 7 | 4801293 | 175 | 4801341 |
| 1.16 | 4801244 | 7.5 | 4801294 | 200 | 4801342 |
| 1.17 | 4801245 | 8 | 4801295 | 281.2 | 4803181 |
| 1.18 | 4801246 | 8.5 | 4801296 | 250 | 4801343 |
| 1.19 | 4801247 | 9 | 4801297 | 300 | 4801344 |
| 1.2 | 4801248 | 9.5 | 4801298 | 400 | 4801346 |
| 1.21 | 4801249 | 10 | 4801299 | 481.1 | 4803182 |
| 1.22 | 4801250 | 10.5 | 4801300 | 500 | 4801348 |
| 1.23 | 4801251 | 11 | 4801301 | 600 | 4801349 |
| 1.24 | 4801252 | 11.5 | 4801302 | 700 | 4801350 |
| 1.25 | 4801253 | 12 | 4801303 | 800 | 4801351 |
| 1.26 | 4801254 | 12.5 | 4801304 | 900 | 4801352 |
| 1.27 | 4801255 | 13 | 4801305 | 1000 | 4801353 |
| 1.28 | 4801256 | 13.5 | 4801306 | | |
| 1.29 | 4801257 | 14 | 4801307 | | |

MarGage 417/2

Rectangular gage blocks made of steel (Tolerance class 2)

FEATURES

- From nominal size 125 mm on, also supplied with wooden case
- Special sizes are available upon request
- Coefficient of linear expansion: $11.5 \times 10^{-6} \text{ K}^{-1}$



| Nominal size mm | Order no. | Nominal size mm | Order no. | Nominal size mm | Order no. |
|-----------------|-----------|-----------------|-----------|-----------------|-----------|
| 0.5 | 4801409 | 1.3 | 4801458 | 14.5 | 4801508 |
| 0.55 | 4801777 | 1.31 | 4801459 | 15 | 4801509 |
| 0.6 | 4801778 | 1.32 | 4801460 | 15.5 | 4801510 |
| 0.65 | 4801779 | 1.33 | 4801461 | 16 | 4801511 |
| 0.7 | 4801780 | 1.34 | 4801462 | 16.5 | 4801512 |
| 0.75 | 4801781 | 1.35 | 4801463 | 17 | 4801513 |
| 0.8 | 4801782 | 1.36 | 4801464 | 17.5 | 4801514 |
| 0.85 | 4801783 | 1.37 | 4801465 | 18 | 4801515 |
| 0.9 | 4801784 | 1.38 | 4801466 | 18.5 | 4801516 |
| 0.95 | 4801785 | 1.39 | 4801467 | 19 | 4801517 |
| 1 | 4801419 | 1.4 | 4801468 | 19.5 | 4801518 |
| 1.0005 | 4803068 | 1.41 | 4801469 | 20 | 4801519 |
| 1.001 | 4801420 | 1.42 | 4801470 | 20.5 | 4801520 |
| 1.002 | 4801421 | 1.43 | 4801471 | 21 | 4801521 |
| 1.003 | 4801422 | 1.44 | 4801472 | 21.5 | 4801522 |
| 1.004 | 4801423 | 1.45 | 4801473 | 22 | 4801523 |
| 1.005 | 4801424 | 1.46 | 4801474 | 22.5 | 4801524 |
| 1.006 | 4801425 | 1.47 | 4801475 | 23 | 4801525 |
| 1.007 | 4801426 | 1.48 | 4801476 | 23.5 | 4801526 |
| 1.008 | 4801427 | 1.49 | 4801477 | 24 | 4801527 |
| 1.009 | 4801428 | 1.5 | 4801478 | 24.5 | 4801528 |
| 1.01 | 4801429 | 1.6 | 4801479 | 25 | 4801529 |
| 1.02 | 4801430 | 1.7 | 4801480 | 30 | 4801530 |
| 1.03 | 4801431 | 1.8 | 4801481 | 40 | 4801531 |
| 1.04 | 4801432 | 1.9 | 4801482 | 41.3 | 4803329 |
| 1.05 | 4801433 | 2 | 4801483 | 50 | 4801532 |
| 1.06 | 4801434 | 2.5 | 4801484 | 60 | 4801533 |
| 1.07 | 4801435 | 3 | 4801485 | 70 | 4801534 |
| 1.08 | 4801436 | 3.5 | 4801486 | 75 | 4801535 |
| 1.09 | 4801437 | 4 | 4801487 | 80 | 4801536 |
| 1.1 | 4801438 | 4.5 | 4801488 | 90 | 4801537 |
| 1.11 | 4801439 | 5 | 4801489 | 100 | 4801538 |
| 1.12 | 4801440 | 5.5 | 4801490 | 125 | 4801539 |
| 1.13 | 4801441 | 6 | 4801491 | 131.4 | 4803330 |
| 1.14 | 4801442 | 6.5 | 4801492 | 150 | 4801540 |
| 1.15 | 4801443 | 7 | 4801493 | 175 | 4801541 |
| 1.16 | 4801444 | 7.5 | 4801494 | 200 | 4801542 |
| 1.17 | 4801445 | 8 | 4801495 | 243.5 | 4803331 |
| 1.18 | 4801446 | 8.5 | 4801496 | 250 | 4801543 |
| 1.19 | 4801447 | 9 | 4801497 | 300 | 4801544 |
| 1.2 | 4801448 | 9.5 | 4801498 | 481.1 | 4803382 |
| 1.21 | 4801449 | 10 | 4801499 | 400 | 4801546 |
| 1.22 | 4801450 | 10.5 | 4801500 | 500 | 4801548 |
| 1.23 | 4801451 | 11 | 4801501 | 600 | 4801549 |
| 1.24 | 4801452 | 11.5 | 4801502 | 700 | 4801550 |
| 1.25 | 4801453 | 12 | 4801503 | 800 | 4801551 |
| 1.26 | 4801454 | 12.5 | 4801504 | 900 | 4801552 |
| 1.27 | 4801455 | 13 | 4801505 | 1000 | 4801553 |
| 1.28 | 4801456 | 13.5 | 4801506 | | |
| 1.29 | 4801457 | 14 | 4801507 | | |

MarGage 417 C/0

Rectangular gage blocks made of ceramic (Tolerance class 0)

FEATURES

- The outstanding properties of Mahr's ceramic parallel gage blocks offer enormous flexibility in day-to-day use. Ceramic end gages can be used without limitations both in inspection rooms and in the harsh workshop environment
- **Easy to handle:** no end gage material is easier to handle than ceramic - easy to slide, corrosion-free, no need for lubrication, lightweight and scratch-resistant
- **Resistant to impact and breakage:** damage to measuring surfaces from scratches or to edges from impact causes minimal burring. Therefore sliding ability is retained
- **Extremely wear-resistant:** the longest life and highest stability of any material currently used in measuring technology. Allows for significantly longer gage monitoring intervals
- **Corrosion-resistant:** ceramic is highly resistant to lyes, acids, oil, grinding water and other aggressive media, even without protective measures
- **Coefficient of expansion similar to that of steel:** therefore there are no usage restrictions, in manufacturing or in the laboratory, even in extreme temperature conditions
- **Non-magnetizable:** ceramic is antistatic, anti-magnetic and non-conductive. It does not attract dirt or dust and is suitable for use in the vicinity of magnetic fields
- **Coefficient of linear expansion:** $9.3 \times 10^{-6} \text{ K}^{-1}$



| Nominal size mm | Order no. |
|-----------------|-----------|
| 0.5 | 4804000 |
| 1 | 4804010 |
| 1.0005 | 4804759 |
| 1.001 | 4804011 |
| 1.002 | 4804012 |
| 1.003 | 4804013 |
| 1.004 | 4804014 |
| 1.005 | 4804015 |
| 1.006 | 4804016 |
| 1.007 | 4804017 |
| 1.008 | 4804018 |
| 1.009 | 4804019 |
| 1.01 | 4804020 |
| 1.02 | 4804021 |
| 1.03 | 4804022 |
| 1.04 | 4804023 |
| 1.05 | 4804024 |
| 1.06 | 4804025 |
| 1.07 | 4804026 |
| 1.08 | 4804027 |
| 1.09 | 4804028 |
| 1.1 | 4804029 |
| 1.11 | 4804030 |
| 1.12 | 4804031 |
| 1.13 | 4804032 |
| 1.14 | 4804033 |
| 1.15 | 4804034 |
| 1.16 | 4804035 |
| 1.17 | 4804036 |
| 1.18 | 4804037 |
| 1.19 | 4804038 |
| 1.2 | 4804039 |
| 1.21 | 4804040 |
| 1.22 | 4804041 |
| 1.23 | 4804042 |
| 1.24 | 4804043 |
| 1.25 | 4804044 |
| 1.26 | 4804045 |
| 1.27 | 4804046 |
| 1.28 | 4804047 |
| 1.29 | 4804048 |
| 1.3 | 4804049 |

| Nominal size mm | Order no. |
|-----------------|-----------|
| 1.31 | 4804050 |
| 1.32 | 4804051 |
| 1.33 | 4804052 |
| 1.34 | 4804053 |
| 1.35 | 4804054 |
| 1.36 | 4804055 |
| 1.37 | 4804056 |
| 1.38 | 4804057 |
| 1.39 | 4804058 |
| 1.4 | 4804059 |
| 1.41 | 4804060 |
| 1.42 | 4804061 |
| 1.43 | 4804062 |
| 1.44 | 4804063 |
| 1.45 | 4804064 |
| 1.46 | 4804065 |
| 1.47 | 4804066 |
| 1.48 | 4804067 |
| 1.49 | 4804068 |
| 1.5 | 4804069 |
| 1.6 | 4804070 |
| 1.7 | 4804071 |
| 1.8 | 4804072 |
| 1.9 | 4804073 |
| 2 | 4804074 |
| 2.5 | 4804075 |
| 3 | 4804076 |
| 3.5 | 4804077 |
| 4 | 4804078 |
| 4.5 | 4804079 |
| 5 | 4804080 |
| 5.5 | 4804081 |
| 6 | 4804082 |
| 6.5 | 4804083 |
| 7 | 4804084 |
| 7.5 | 4804085 |
| 8 | 4804086 |
| 8.5 | 4804087 |
| 9 | 4804088 |
| 9.5 | 4804089 |
| 10 | 4804090 |
| 10.5 | 4804091 |

| Nominal size mm | Order no. |
|-----------------|-----------|
| 11 | 4804092 |
| 11.5 | 4804093 |
| 12 | 4804094 |
| 12.5 | 4804095 |
| 13 | 4804096 |
| 13.5 | 4804097 |
| 14 | 4804098 |
| 14.5 | 4804099 |
| 15 | 4804100 |
| 15.5 | 4804101 |
| 16 | 4804102 |
| 16.5 | 4804103 |
| 17 | 4804104 |
| 17.5 | 4804105 |
| 18 | 4804106 |
| 18.5 | 4804107 |
| 19 | 4804108 |
| 19.5 | 4804109 |
| 20 | 4804110 |
| 20.5 | 4804111 |
| 21 | 4804112 |
| 21.5 | 4804113 |
| 22 | 4804114 |
| 22.5 | 4804115 |
| 23 | 4804116 |
| 23.5 | 4804117 |
| 24 | 4804118 |
| 24.5 | 4804119 |
| 25 | 4804120 |
| 30 | 4804121 |
| 40 | 4804122 |
| 50 | 4804123 |
| 60 | 4804124 |
| 70 | 4804125 |
| 75 | 4804126 |
| 80 | 4804127 |
| 90 | 4804128 |
| 100 | 4804129 |

MarGage 417 C/1

Rectangular gage blocks made of ceramic (Tolerance class 1)

FEATURES

- The outstanding properties of Mahr's ceramic parallel gage blocks offer enormous flexibility in day-to-day use. Ceramic end gages can be used without limitations both in inspection rooms and in the harsh workshop environment
- **Easy to handle:** no end gage material is easier to handle than ceramic - easy to slide, corrosion-free, no need for lubrication, lightweight and scratch-resistant
- **Resistant to impact and breakage:** damage to measuring surfaces from scratches or to edges from impact causes minimal burring. Therefore sliding ability is retained
- **Extremely wear-resistant:** the longest life and highest stability of any material currently used in measuring technology. Allows for significantly longer gage monitoring intervals
- **Corrosion-resistant:** ceramic is highly resistant to lyes, acids, oil, grinding water and other aggressive media, even without protective measures
- **Coefficient of expansion similar to that of steel:** therefore there are no usage restrictions, in manufacturing or in the laboratory, even in extreme temperature conditions
- **Non-magnetizable:** ceramic is antistatic, anti-magnetic and non-conductive. It does not attract dirt or dust and is suitable for use in the vicinity of magnetic fields
- **Coefficient of linear expansion:** $9.3 \times 10^{-6} \text{ K}^{-1}$



| Nominal size mm | Order no. |
|-----------------|-----------|
| 0.5 | 4804200 |
| 1 | 4804210 |
| 1.0005 | 4804764 |
| 1.001 | 4804211 |
| 1.002 | 4804212 |
| 1.003 | 4804213 |
| 1.004 | 4804214 |
| 1.005 | 4804215 |
| 1.006 | 4804216 |
| 1.007 | 4804217 |
| 1.008 | 4804218 |
| 1.009 | 4804219 |
| 1.01 | 4804220 |
| 1.02 | 4804221 |
| 1.03 | 4804222 |
| 1.04 | 4804223 |
| 1.05 | 4804224 |
| 1.06 | 4804225 |
| 1.07 | 4804226 |
| 1.08 | 4804227 |
| 1.09 | 4804228 |
| 1.1 | 4804229 |
| 1.11 | 4804230 |
| 1.12 | 4804231 |
| 1.13 | 4804232 |
| 1.14 | 4804233 |
| 1.15 | 4804234 |
| 1.16 | 4804235 |
| 1.17 | 4804236 |
| 1.18 | 4804237 |
| 1.19 | 4804238 |
| 1.2 | 4804239 |
| 1.21 | 4804240 |
| 1.22 | 4804241 |
| 1.23 | 4804242 |
| 1.24 | 4804243 |
| 1.25 | 4804244 |
| 1.26 | 4804245 |
| 1.27 | 4804246 |
| 1.28 | 4804247 |
| 1.29 | 4804248 |
| 1.3 | 4804249 |
| 1.31 | 4804250 |
| 1.32 | 4804251 |

| Nominal size mm | Order no. |
|-----------------|-----------|
| 1.33 | 4804252 |
| 1.34 | 4804253 |
| 1.35 | 4804254 |
| 1.36 | 4804255 |
| 1.37 | 4804256 |
| 1.38 | 4804257 |
| 1.39 | 4804258 |
| 1.4 | 4804259 |
| 1.41 | 4804260 |
| 1.42 | 4804261 |
| 1.43 | 4804262 |
| 1.44 | 4804263 |
| 1.45 | 4804264 |
| 1.46 | 4804265 |
| 1.47 | 4804266 |
| 1.48 | 4804267 |
| 1.49 | 4804268 |
| 1.5 | 4804269 |
| 1.6 | 4804270 |
| 1.7 | 4804271 |
| 1.8 | 4804272 |
| 1.9 | 4804273 |
| 2 | 4804274 |
| 2.5 | 4804275 |
| 3 | 4804276 |
| 3.5 | 4804277 |
| 4 | 4804278 |
| 4.5 | 4804279 |
| 5 | 4804280 |
| 5.1 | 4804751 |
| 5.5 | 4804281 |
| 6 | 4804282 |
| 6.5 | 4804283 |
| 7 | 4804284 |
| 7.5 | 4804285 |
| 7.7 | 4804752 |
| 8 | 4804286 |
| 8.5 | 4804287 |
| 9 | 4804288 |
| 9.5 | 4804289 |
| 10 | 4804290 |
| 10.3 | 4804753 |
| 10.5 | 4804291 |

| Nominal size mm | Order no. |
|-----------------|-----------|
| 11 | 4804292 |
| 11.5 | 4804293 |
| 12 | 4804294 |
| 12.5 | 4804295 |
| 12.9 | 4804754 |
| 13 | 4804296 |
| 13.5 | 4804297 |
| 14 | 4804298 |
| 14.5 | 4804299 |
| 15 | 4804300 |
| 15.5 | 4804301 |
| 16 | 4804302 |
| 16.5 | 4804303 |
| 17 | 4804304 |
| 17.5 | 4804305 |
| 17.6 | 4804755 |
| 18 | 4804306 |
| 18.5 | 4804307 |
| 19 | 4804308 |
| 19.5 | 4804309 |
| 20 | 4804310 |
| 20.2 | 4804756 |
| 20.5 | 4804311 |
| 21 | 4804312 |
| 21.5 | 4804313 |
| 22 | 4804314 |
| 22.5 | 4804315 |
| 22.8 | 4804757 |
| 23 | 4804316 |
| 23.5 | 4804317 |
| 24 | 4804318 |
| 24.5 | 4804319 |
| 25 | 4804320 |
| 30 | 4804321 |
| 40 | 4804322 |
| 41.3 | 4804758 |
| 50 | 4804323 |
| 60 | 4804324 |
| 70 | 4804325 |
| 75 | 4804326 |
| 80 | 4804327 |
| 90 | 4804328 |
| 100 | 4804329 |
| 131.4 | 4804760 |

MarGage 417 C/2

Rectangular gage blocks made of ceramic (Tolerance class 2)

FEATURES

- The outstanding properties of Mahr's ceramic parallel gage blocks offer enormous flexibility in day-to-day use. Ceramic end gages can be used without limitations both in inspection rooms and in the harsh workshop environment
- **Easy to handle:** no end gage material is easier to handle than ceramic - easy to slide, corrosion-free, no need for lubrication, lightweight and scratch-resistant
- **Resistant to impact and breakage:** damage to measuring surfaces from scratches or to edges from impact causes minimal burring. Therefore sliding ability is retained
- **Extremely wear-resistant:** the longest life and highest stability of any material currently used in measuring technology. Allows for significantly longer gage monitoring intervals
- **Corrosion-resistant:** ceramic is highly resistant to lyes, acids, oil, grinding water and other aggressive media, even without protective measures
- **Coefficient of expansion similar to that of steel:** therefore there are no usage restrictions, in manufacturing or in the laboratory, even in extreme temperature conditions
- **Non-magnetizable:** ceramic is antistatic, anti-magnetic and non-conductive. It does not attract dirt or dust and is suitable for use in the vicinity of magnetic fields
- **Coefficient of linear expansion:** $9.3 \times 10^{-6} \text{ K}^{-1}$



| Nominal size mm | Order no. |
|-----------------|-----------|
| 0.5 | 4804400 |
| 1 | 4804410 |
| 1.0005 | 4804765 |
| 1.001 | 4804411 |
| 1.002 | 4804412 |
| 1.003 | 4804413 |
| 1.004 | 4804414 |
| 1.005 | 4804415 |
| 1.006 | 4804416 |
| 1.007 | 4804417 |
| 1.008 | 4804418 |
| 1.009 | 4804419 |
| 1.01 | 4804420 |
| 1.02 | 4804421 |
| 1.03 | 4804422 |
| 1.04 | 4804423 |
| 1.05 | 4804424 |
| 1.06 | 4804425 |
| 1.07 | 4804426 |
| 1.08 | 4804427 |
| 1.09 | 4804428 |
| 1.1 | 4804429 |
| 1.11 | 4804430 |
| 1.12 | 4804431 |
| 1.13 | 4804432 |
| 1.14 | 4804433 |
| 1.15 | 4804434 |
| 1.16 | 4804435 |
| 1.17 | 4804436 |
| 1.18 | 4804437 |
| 1.19 | 4804438 |
| 1.2 | 4804439 |
| 1.21 | 4804440 |
| 1.22 | 4804441 |
| 1.23 | 4804442 |
| 1.24 | 4804443 |
| 1.25 | 4804444 |
| 1.26 | 4804445 |
| 1.27 | 4804446 |
| 1.28 | 4804447 |
| 1.29 | 4804448 |
| 1.3 | 4804449 |
| 1.31 | 4804450 |
| 1.32 | 4804451 |

| Nominal size mm | Order no. |
|-----------------|-----------|
| 1.33 | 4804452 |
| 1.34 | 4804453 |
| 1.35 | 4804454 |
| 1.36 | 4804455 |
| 1.37 | 4804456 |
| 1.38 | 4804457 |
| 1.39 | 4804458 |
| 1.4 | 4804459 |
| 1.41 | 4804460 |
| 1.42 | 4804461 |
| 1.43 | 4804462 |
| 1.44 | 4804463 |
| 1.45 | 4804464 |
| 1.46 | 4804465 |
| 1.47 | 4804466 |
| 1.48 | 4804467 |
| 1.49 | 4804468 |
| 1.5 | 4804469 |
| 1.6 | 4804470 |
| 1.7 | 4804471 |
| 1.8 | 4804472 |
| 1.9 | 4804473 |
| 2 | 4804474 |
| 2.5 | 4804475 |
| 3 | 4804476 |
| 3.5 | 4804477 |
| 4 | 4804478 |
| 4.5 | 4804479 |
| 5 | 4804480 |
| 5.1 | 4806114 |
| 5.5 | 4804481 |
| 6 | 4804482 |
| 6.5 | 4804483 |
| 7 | 4804484 |
| 7.5 | 4804485 |
| 7.7 | 4806115 |
| 8 | 4804486 |
| 8.5 | 4804487 |
| 9 | 4804488 |
| 9.5 | 4804489 |
| 10 | 4804490 |
| 10.3 | 4806116 |
| 10.5 | 4804491 |
| 11 | 4804492 |

| Nominal size mm | Order no. |
|-----------------|-----------|
| 11.5 | 4804493 |
| 12 | 4804494 |
| 12.5 | 4804495 |
| 12.9 | 4806117 |
| 13 | 4804496 |
| 13.5 | 4804497 |
| 14 | 4804498 |
| 14.5 | 4804499 |
| 15 | 4804500 |
| 15.5 | 4804501 |
| 16 | 4804502 |
| 16.5 | 4804503 |
| 17 | 4804504 |
| 17.5 | 4804505 |
| 17.6 | 4806118 |
| 18 | 4804506 |
| 18.5 | 4804507 |
| 19 | 4804508 |
| 19.5 | 4804509 |
| 20 | 4804510 |
| 20.2 | 4806119 |
| 20.5 | 4804511 |
| 21 | 4804512 |
| 21.5 | 4804513 |
| 22 | 4804514 |
| 22.5 | 4804515 |
| 22.8 | 4806120 |
| 23 | 4804516 |
| 23.5 | 4804517 |
| 24 | 4804518 |
| 24.5 | 4804519 |
| 25 | 4804520 |
| 30 | 4804521 |
| 40 | 4804522 |
| 41.3 | 4806121 |
| 50 | 4804523 |
| 60 | 4804524 |
| 70 | 4804525 |
| 75 | 4804526 |
| 80 | 4804527 |
| 90 | 4804528 |
| 100 | 4804529 |
| 131.4 | 4806122 |

MarGage 420

Gage block holder and measuring jaws accessory set

FEATURES

- To be used in conjunction with gage blocks for gaging both workpieces and fixtures
- Package contains: wooden case

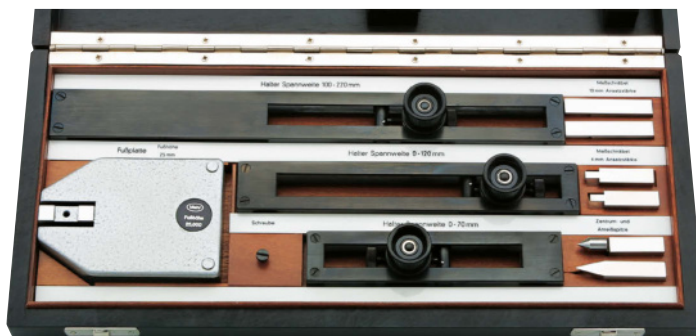

Application:

- To measure and calibrate setting gages and measuring instruments
- For scribing and marking

TECHNICAL DATA

| Order no. | Type |
|-----------|------|
| 4800100 | 420 |

ACCESSORIES

| Order no. | Description | Type |
|-----------|--|-------|
| 4800110 | Hemispherical measuring jaws, approach $2 \times 2 \text{ mm} = 4 \text{ mm}$ | 420 m |
| 4800111 | Hemispherical measuring jaws, approach $2 \times 5 \text{ mm} = 10 \text{ mm}$ | 420 m |
| 4800112 | Scriber tip | 420 a |
| 4800113 | Centering point | 420 z |
| 4800114 | Stand | 420 f |
| 4800120 | Holder, span width 0 –70 mm | 420 h |
| 4800121 | Holder, span width 0 –120 mm | 420 h |
| 4800122 | Holder, span width 100 –220 mm | 420 h |
| 4800123 | Holder, span width 100 –420 mm | 420 h |
| 4800124 | Holder, span width 400 –820 mm | 420 h |

MarGage 424

Gage block maintenance accessories

FEATURES

The main tools for testing and repairing parallel gage blocks:

Optical flat 421

- For checking the flatness of the measuring surface by the interference method, Ø 45 mm

Wooden tongs 423

- For heat-insulation when holding parallel gage blocks
 - **Granite lapping plate**
 - For removing ridges and damage from gage block surfaces.
High-precision model
 - **Special Vaseline tin**
 - For anti-corrosive protection of parallel steel gage blocks
 - **Brush and suede cloth**
 - For cleaning the parallel gage blocks
- Package contains: case



TECHNICAL DATA

| Order no. | Type |
|-----------|------|
| 4800130 | 424 |

ACCESSORIES

| Order no. | Description | Type |
|-----------|--|------|
| 4800142 | Wooden tongs, single, to prevent heat transfer when handling gage blocks | 423 |



423

MarGage 421

Optical flat

FEATURES

- Package contains: case

Application:

- For testing the flatness of high precision measuring surfaces (by the interference method) on gage blocks and measuring equipment and on precision components with similarly challenging surfaces



TECHNICAL DATA

| Order no. | Type | Diameter | Thickness | Flatness deviation |
|-----------|------|-----------|-----------|----------------------|
| 4800135 | 421 | mm 100 | mm 20 | μm 0.1 |
| 4800140 | 421 | 45 | 11 | 0.1 |

MarGage 421 P

Optical parallel

FEATURES

- Package contains: case

Application:

- For simultaneous testing of parallelism and flatness of plan measuring surfaces of outside micrometers and snap gages by interference method



TECHNICAL DATA

| Order no. | Type | Diameter | Thickness | Flatness deviation | Parallelism deviation |
|-----------|-------|----------|-----------|--------------------|-----------------------|
| 4800180 | 421 P | 30 | 12 | 0.15 | 0.3 |

MarGage 421 PS

Optical parallels

FEATURES

- Package contains: case



Application:

- For simultaneous testing of parallelism and flatness of planar measuring surfaces of outside micrometers and indicating snap gages by the interference method
- 4 different thicknesses, for parallelism testing in different spindle settings (rotating spindles)



TECHNICAL DATA

| Order no. | Type | Diameter | Measuring range | Nominal size | Flatness deviation | Parallelism deviation | Quantity per set |
|-----------|--------|----------|------------------|--------------|--------------------|-----------------------|------------------|
| | | mm | mm | mm | µm | µm | Pieces |
| 4800185 | 421 PS | 30 | 0–25 mm / 0–1" | 12 | 0.15 | 0.3 | 4 |
| 4800186 | 421 PS | 30 | 25–50 mm / 1–2" | 25 | 0.15 | 0.3 | 4 |
| 4800187 | 421 PS | 30 | 50–75 mm / 2–3" | 50 | 0.15 | 0.5 | 4 |
| 4800188 | 421 PS | 30 | 75–100 mm / 3–4" | 75 | 0.15 | 0.5 | 4 |

MarGage 426 A

Thread pin gage

FEATURES

- To hang above the testpiece
- Set consists of 3 pin gages
- Manufacturing tolerance $\pm 0.5 \mu\text{m}$
- Pin gage length: 32 mm



Application:

- For determining pitch diameter of external threads according to the three wire method

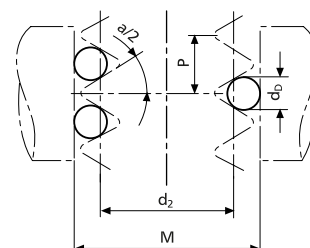

TECHNICAL DATA

| Order no. | Type | Diameter | Metric | Whitworth range per 1 inch | UST heats per 1 inch | Trapezoid | Manufacturing tolerance +/- |
|-----------|-------|----------|------------------|----------------------------|----------------------|-----------|-----------------------------|
| | | mm | mm | TPI | TPI | mm | μm |
| 4821000 | 426 A | 0.17 | 0.25 / 0.3 | | | | 0.5 |
| 4821001 | 426 A | 0.195 | | | 80 | | 0.5 |
| 4821002 | 426 A | 0.22 | 0.35 | | 72 | | 0.5 |
| 4821003 | 426 A | 0.25 | 0.4 | | 64 | | 0.5 |
| 4821004 | 426 A | 0.29 | 0.45 / 0.5 | | 56 | | 0.5 |
| 4821005 | 426 A | 0.335 | 0.6 | | 48 | | 0.5 |
| 4821006 | 426 A | 0.39 | | 40 | 44 / 40 | | 0.5 |
| 4821007 | 426 A | 0.455 | 0.7 / 0.75 / 0.8 | 32 | 36 | | 0.5 |
| 4821008 | 426 A | 0.53 | | 28 | 32 / 28 | | 0.5 |
| 4821009 | 426 A | 0.62 | 1 | 26 / 24 | 24 | | 0.5 |
| 4821010 | 426 A | 0.725 | 1.25 | 22 / 20 | 20 | | 0.5 |
| 4821011 | 426 A | 0.895 | 1.5 | 19 / 18 / 16 | 18 | | 0.5 |
| 4821012 | 426 A | 1.1 | 1.75 | 14 | 16 / 14 / 13 | | 0.5 |
| 4821013 | 426 A | 1.35 | 2 | 12 / 11 | 12 / 11 | | 0.5 |
| 4821014 | 426 A | 1.65 | 2.5 | 10 / 9 | 10 / 9 | 3 | 0.5 |
| 4821015 | 426 A | 2.05 | 3 / 3.5 | 8 / 7 | 8 / 7 | 4 | 0.5 |
| 4821016 | 426 A | 2.55 | 4 / 4.5 | 6 | 6 | 5 | 0.5 |
| 4821017 | 426 A | 3.2 | 5 / 5.5 | 5 / 4.5 | 5 / 4.5 | 6 | 0.5 |
| 4821018 | 426 A | 4 | 6 | 4 / 3.5 | 4 | 7 | 0.5 |

MarGage 426 M

Thread pin gages, holder pair

FEATURES

- For determining the pitch diameter of external threads by the three-wire method
- In conjunction with outside micrometers, indicating measuring instruments or measuring machines
- Each pair consists of one holder with 1 pin gage and one holder with 2 pin gages
- Holder has a satin chrome finish, the retainer ring can be locked yet the rotating spindle can still rotate
- Pin gages are hardened and lapped - freely floating in holder to allow proper positioning and contact with thread flanks
- Manufacturing tolerance $\pm 0.5 \mu\text{m}$
- Mounting bore 6.35 mm = 1/4", 8 mm on request)
- For threads with outer diameter up to 95 mm

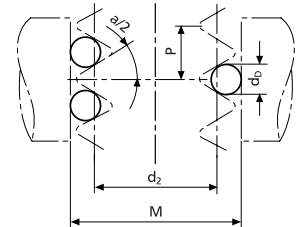
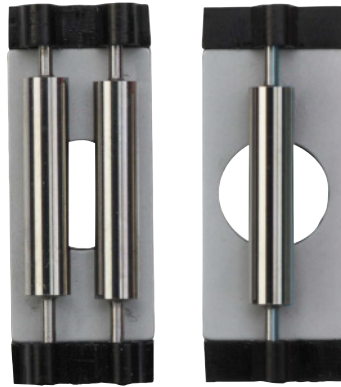

TECHNICAL DATA

| Order no. | Type | Mounting hole | Diameter | Metric | Whitworth range per 1 inch | UST heats per 1 inch | Trapezoid |
|-----------|-------|---------------|----------|------------------|----------------------------|----------------------|-----------|
| | | | mm | mm | | | mm |
| 4820010 | 426 M | 7.5 mm | 0.17 | 0.25 / 0.3 | | | |
| 4820011 | 426 M | 7.5 mm | 0.195 | | | 80 | |
| 4820012 | 426 M | 7.5 mm | 0.22 | 0.35 | | 72 | |
| 4820013 | 426 M | 7.5 mm | 0.25 | 0.4 | | 64 | |
| 4820014 | 426 M | 7.5 mm | 0.29 | 0.45 / 0.5 | | 56 | |
| 4820015 | 426 M | 7.5 mm | 0.335 | 0.6 | | 48 | |
| 4820016 | 426 M | 7.5 mm | 0.39 | | 40 | 44 / 40 | |
| 4820017 | 426 M | 7.5 mm | 0.455 | 0.7 / 0.75 / 0.8 | 32 | 36 | |
| 4820018 | 426 M | 7.5 mm | 0.53 | | 28 | 32 / 28 | |
| 4820019 | 426 M | 7.5 mm | 0.62 | 1 | 26 / 24 | 24 | |
| 4820020 | 426 M | 7.5 mm | 0.725 | 1.25 | 22 / 20 | 20 | |
| 4820021 | 426 M | 7.5 mm | 0.895 | 1.5 | 19 / 18 / 16 | 18 | |
| 4820022 | 426 M | 7.5 mm | 1.1 | 1.75 | 14 | 16 / 14 / 13 | |
| 4820023 | 426 M | 7.5 mm | 1.35 | 2 | 12 / 11 | 12 / 11 | |
| 4820024 | 426 M | 7.5 mm | 1.65 | 2.5 | 10 / 9 | 10 / 9 | 3 |
| 4820025 | 426 M | 7.5 mm | 2.05 | 3 / 3.5 | 8 / 7 | 8 / 7 | 4 |
| 4820026 | 426 M | 7.5 mm | 2.55 | 4 / 4.5 | 6 | 6 | 5 |
| 4820027 | 426 M | 7.5 mm | 3.2 | 5 / 5.5 | 5 / 4.5 | 5 / 4.5 | 6 |
| 4820028 | 426 M | 7.5 mm | 4 | 6 | 4 / 3.5 | 4 | 7 |
| 4820131 | 426 M | 6.5 mm | 0.25 | 0.4 | | 64 | |
| 4820132 | 426 M | 6.5 mm | 0.17 | 0.25 / 0.3 | | | |
| 4820133 | 426 M | 6.5 mm | 0.22 | 0.35 | | 72 | |
| 4820134 | 426 M | 6.5 mm | 0.29 | 0.45 / 0.5 | | 56 | |
| 4820135 | 426 M | 6.5 mm | 0.335 | 0.6 | | 48 | |
| 4820137 | 426 M | 6.5 mm | 0.455 | 0.7 / 0.75 / 0.8 | 32 | 36 | |
| 4820139 | 426 M | 6.5 mm | 0.62 | 1 | 26 / 24 | 24 | |
| 4820140 | 426 M | 6.5 mm | 0.725 | 1.25 | 22 / 20 | 20 | |
| 4820141 | 426 M | 6.5 mm | 0.895 | 1.5 | 19 / 18 / 16 | 18 | |
| 4820142 | 426 M | 6.5 mm | 1.1 | 1.75 | 14 | 16 / 14 / 13 | |
| 4820143 | 426 M | 6.5 mm | 1.35 | 2 | 12 / 11 | 12 / 11 | |
| 4820144 | 426 M | 6.5 mm | 1.65 | 2.5 | 10 / 9 | 10 / 9 | 3 |
| 4820145 | 426 M | 6.5 mm | 2.05 | 3 / 3.5 | 8 / 7 | 8 / 7 | 4 |
| 4820146 | 426 M | 6.5 mm | 2.55 | 4 / 4.5 | 6 | 6 | 5 |
| 4820147 | 426 M | 6.5 mm | 3.2 | 5 / 5.5 | 5 / 4.5 | 5 / 4.5 | 6 |
| 4820149 | 426 M | 6.5 mm | 0.195 | | | 80 | |
| 4820150 | 426 M | 6.5 mm | 0.39 | | | 44 / 40 | |
| 4820151 | 426 M | 6.5 mm | 0.53 | | | 32 / 28 | |
| 4820152 | 426 M | 6.5 mm | 4 | 6 | | | 7 |

MarGage 426 MS

Thread pin gages set

FEATURES

- Set of thread pin gages in holder consists of: 18 holder pairs 426 M
- Diameter 0.17 – 3.2 mm
- For threads with outside diameter up to 95 mm
- Package contains: wooden case

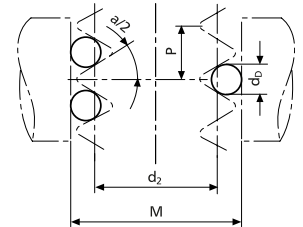

TECHNICAL DATA

| Order no. | Type | Mounting hole |
|-----------|--------|---------------|
| | | mm |
| 4820000 | 426 MS | 7.5 mm |
| 4820002 | 426 MS | 8.0 mm |
| 4820003 | 426 MS | 6.5 mm |
| 4820004 | 426 MS | 6.35 mm |

MarGage 355 E

Ring gage with tolerance class

FEATURES

- Wear-resistant special gage steel
- Hardened and lapped
- Structural dimensions: DIN 2250, version C
- Manufacturing tolerance: DIN 2250 (JS4)
- Uncertainty of the actual size: 1/2 IT 1

| Diameter mm | Order no. | Diameter mm | Order no. |
|-------------|-----------|-------------|-----------|
| 1 | 4710006 | 52 | 4710072 |
| 2 | 4710010 | 53 | 4710073 |
| 3 | 4710014 | 54 | 4710074 |
| 4 | 4710018 | 55 | 4710075 |
| 5 | 4710020 | 56 | 4710076 |
| 6 | 4710022 | 57 | 4710077 |
| 7 | 4710024 | 58 | 4710078 |
| 8 | 4710026 | 59 | 4710079 |
| 9 | 4710028 | 60 | 4710080 |
| 10 | 4710030 | 61 | 4710081 |
| 11 | 4710031 | 62 | 4710082 |
| 12 | 4710032 | 63 | 4710083 |
| 13 | 4710033 | 64 | 4710084 |
| 14 | 4710034 | 65 | 4710085 |
| 15 | 4710035 | 66 | 4710086 |
| 16 | 4710036 | 67 | 4710087 |
| 17 | 4710037 | 68 | 4710088 |
| 18 | 4710038 | 69 | 4710089 |
| 19 | 4710039 | 70 | 4710090 |
| 20 | 4710040 | 71 | 4710091 |
| 21 | 4710041 | 72 | 4710092 |
| 22 | 4710042 | 73 | 4710093 |
| 23 | 4710043 | 74 | 4710094 |
| 24 | 4710044 | 75 | 4710095 |
| 25 | 4710045 | 76 | 4710096 |
| 26 | 4710046 | 77 | 4710097 |
| 27 | 4710047 | 78 | 4710098 |
| 28 | 4710048 | 79 | 4710099 |
| 29 | 4710049 | 80 | 4710100 |
| 30 | 4710050 | 81 | 4710101 |
| 31 | 4710051 | 82 | 4710102 |
| 32 | 4710052 | 83 | 4710103 |
| 33 | 4710053 | 84 | 4710104 |
| 34 | 4710054 | 85 | 4710105 |
| 35 | 4710055 | 86 | 4710106 |
| 36 | 4710056 | 87 | 4710107 |
| 37 | 4710057 | 88 | 4710108 |
| 38 | 4710058 | 89 | 4710109 |
| 39 | 4710059 | 90 | 4710110 |
| 40 | 4710060 | 91 | 4710111 |
| 41 | 4710061 | 92 | 4710112 |
| 42 | 4710062 | 93 | 4710113 |
| 43 | 4710063 | 94 | 4710114 |
| 44 | 4710064 | 95 | 4710115 |
| 45 | 4710065 | 96 | 4710116 |
| 46 | 4710066 | 97 | 4710117 |
| 47 | 4710067 | 98 | 4710118 |
| 48 | 4710068 | 99 | 4710119 |
| 49 | 4710069 | 100 | 4710120 |
| 50 | 4710070 | 125 | 4710121 |
| 51 | 4710071 | 175 | 4710122 |



MarGage 355 E

Ring gage with tolerance class

FEATURES

- Wear-resistant special gage steel
- Hardened and lapped
- Structural dimensions: DIN 2250, version C
- Manufacturing tolerance: DIN 2250 (JS4)
- Uncertainty of the actual size: 1/2 IT 1
- Gradation 1 mm
- Please specify diameter when placing order

| Ø mm | Order no. |
|----------|-----------|
| 101 –105 | 4714201 |
| 106 –110 | 4714202 |
| 111 –115 | 4714203 |
| 116 –120 | 4714204 |
| 121 –124 | 4714205 |
| 126 –130 | 4714206 |
| 131 –135 | 4714207 |
| 136 –140 | 4714208 |
| 141 –145 | 4714209 |
| 146 –150 | 4714210 |
| 151 –155 | 4714211 |
| 156 –160 | 4714212 |
| 161 –165 | 4714213 |
| 166 –170 | 4714214 |
| 171 –174 | 4714215 |
| 176 –180 | 4714216 |
| 181 –185 | 4714217 |
| 186 –190 | 4714218 |
| 191 –195 | 4714219 |
| 196 –200 | 4714220 |



MarGage 355 E

Ring gage with tolerance class

FEATURES

- Wear-resistant special gage steel
- Hardened and lapped
- Structural dimensions: DIN 2250, version C
- Manufacturing tolerance: DIN 2250 (JS4)
- Uncertainty of the actual size: 1/2 IT 1
- Gradation 0.001 mm
- Please specify diameter when placing order

| Ø mm | Order no. |
|--------------|-----------|
| 1 –1.8 | 4732600 |
| 1.801 –3 | 4732641 |
| 3.001 –5 | 4732642 |
| 5.001 –10 | 4732635 |
| 10.001 –15 | 4732602 |
| 15.001 –20 | 4732603 |
| 20.001 –25 | 4732604 |
| 25.001 –32 | 4732605 |
| 32.001 –35 | 4732606 |
| 35.001 –40 | 4732607 |
| 40.001 –45 | 4732608 |
| 45.001 –50 | 4732609 |
| 50.001 –55 | 4732610 |
| 55.001 –60 | 4732611 |
| 60.001 –65 | 4732612 |
| 65.001 –70 | 4732613 |
| 70.001 –75 | 4732614 |
| 75.001 –80 | 4732615 |
| 80.001 –85 | 4732616 |
| 85.001 –90 | 4732617 |
| 90.001 –95 | 4732618 |
| 95.001 –100 | 4732619 |
| 100.001 –105 | 4732620 |
| 105.001 –110 | 4732636 |
| 110.001 –115 | 4732621 |
| 115.001 –120 | 4732637 |
| 120.001 –125 | 4732622 |
| 125.001 –130 | 4732638 |
| 130.001 –135 | 4732623 |
| 135.001 –140 | 4732639 |
| 140.001 –145 | 4732624 |
| 145.001 –150 | 4732640 |
| 150.001 –155 | 4732625 |
| 155.001 –160 | 4732626 |
| 160.001 –165 | 4732627 |
| 165.001 –170 | 4732628 |
| 170.001 –175 | 4732629 |
| 175.001 –180 | 4732630 |
| 180.001 –185 | 4732631 |
| 185.001 –190 | 4732632 |
| 190.001 –195 | 4732633 |
| 195.001 –200 | 4732634 |



MarGage 390

Setting disc with tolerance class

FEATURES

- Wear-resistant special gage steel
- Hardened and lapped
- Manufacturing tolerance:
 $\pm 1/2$ IT 2
- Uncertainty of the actual size:
 $1/2$ IT 1
- The ideal setting standards for the Marameter 840 F and 300 P indicating snap gage families

| Diameter mm | Order no. |
|----------------|-----------|
| 10 | 4717030 |
| 11 | 4717031 |
| 12 | 4717032 |
| 13 | 4717033 |
| 14 | 4717034 |
| 15 | 4717035 |
| 16 | 4717036 |
| 17 | 4717037 |
| 18 | 4717038 |
| 19 | 4717039 |
| 20 | 4717040 |
| 21 | 4717041 |
| 22 | 4717042 |
| 23 | 4717043 |
| 24 | 4717044 |
| 25 | 4717045 |
| 26 | 4717046 |
| 27 | 4717047 |
| 28 | 4717048 |
| 29 | 4717049 |
| 30 | 4717050 |
| 31 | 4717051 |
| 32 | 4717052 |
| 33 | 4717053 |
| 34 | 4717054 |
| 35 | 4717055 |
| 36 | 4717056 |
| 37 | 4717057 |
| 38 | 4717058 |
| 39 | 4717059 |
| 40 | 4717060 |
| 41 | 4717061 |
| 42 | 4717062 |
| 43 | 4717063 |
| 44 | 4717064 |
| 45 | 4717065 |
| 46 | 4717066 |
| 47 | 4717067 |
| 48 | 4717068 |
| 49 | 4717069 |
| 50 | 4717070 |
| 51 | 4717071 |
| 52 | 4717072 |
| 53 | 4717073 |
| 54 | 4717074 |
| 55 | 4717075 |
| 56 | 4717076 |
| 57 | 4717077 |
| 58 | 4717078 |
| 59 | 4717079 |
| 60 | 4717080 |
| 61 | 4717081 |
| 62 | 4717082 |
| 63 | 4717083 |
| 64 | 4717084 |
| 65 | 4717085 |
| 66 | 4717086 |
| 67 | 4717087 |
| 68 | 4717088 |



MarGage 390

Setting disc with tolerance class

| Diameter mm | Order no. |
|----------------|-----------|
| 69 | 4717089 |
| 70 | 4717090 |
| 71 | 4717091 |
| 72 | 4717092 |
| 73 | 4717093 |
| 74 | 4717094 |
| 75 | 4717095 |
| 76 | 4717096 |
| 77 | 4717097 |
| 78 | 4717098 |
| 79 | 4717099 |
| 80 | 4717100 |
| 81 | 4717101 |
| 82 | 4717102 |
| 83 | 4717103 |
| 84 | 4717104 |
| 85 | 4717105 |
| 86 | 4717106 |
| 87 | 4717107 |
| 88 | 4717108 |
| 89 | 4717109 |
| 90 | 4717110 |
| 91 | 4717111 |
| 92 | 4717112 |
| 93 | 4717113 |
| 94 | 4717114 |
| 95 | 4717115 |
| 96 | 4717116 |
| 97 | 4717117 |
| 98 | 4717118 |
| 99 | 4717119 |
| 100 | 4717120 |

MarGage 390

Setting disc with tolerance class

FEATURES

- Wear-resistant special gage steel
- Hardened and lapped
- Manufacturing tolerance:
 $\pm 1/2$ IT 2
- Uncertainty of the actual size:
 $1/2$ IT 1
- The ideal setting standards for
the Marameter 840 F and 300 P
indicating snap gage families
- Gradation 0.001 mm
- Please specify diameter
when placing order

| \varnothing mm | Order no. |
|---------------------|-----------|
| 10.001 –14 | 4719900 |
| 14.001 –20 | 4719901 |
| 20.001 –30 | 4719902 |
| 30.001 –40 | 4719903 |
| 40.001 –50 | 4719904 |
| 50.001 –60 | 4719905 |
| 60.001 –70 | 4719906 |
| 70.001 –80 | 4719907 |
| 80.001 –90 | 4719908 |
| 90.001 –100 | 4719909 |



Digimar | Height measuring instruments

Whether it's simply scribing a workpiece or completing complex measurements in two dimensions – Digimar guarantees maximum flexibility and quality. Our motorized height measuring instruments are simple to operate and provide a high level of measuring convenience and reliability.



| | |
|---|------------|
| Digimar overview | 474 |
| Height measuring instruments | |
| Digimar 817 CLT | 476 |
| Height measuring instrument | |
| Digimar 816 CL | 477 |
| Height measuring instrument | |
| Digimar accessories | 478 |
| Digimar 814 N | 485 |
| With cast base | |
| Digimar 814 G | 487 |
| With granite table plate | |
| Digimar 814 SR | 489 |
| Height measuring and scribing instruments | |

Digimar 817 CLT: Easy measurements using intuitive touch control



Best connection for secure data

Data can be transferred wirelessly or via USB cable via the MarConnect interface. Quickly print out a series of measurements with an available Bluetooth printer. Simply choose between complete measuring records in PDF format or save your measuring records as a TXT file.



Interfaces for dial indicators

An interface integrated in the slide enables the error-free measurement of the perpendicularity and straightness using the new Millimes 2000/2001W dial comparators.



Ergonomics that can be measured

Ergonomics means that the methods, processes, and arrangement are designed for people and not the other way around. This is exactly what the new Digimar 817 CLT stands for: The simple moving and scrolling functions of the touchscreen work just like smartphones and tablets. The keys on the display are already arranged in such a way that frequently used functions are particularly easy to access. The measurements on the measuring slide can easily be started by hand via the touch display, the thumbwheel with integrated arrow keys, or using Quick mode. Two push buttons to actuate the air bearings are integrated into the handle enabling the device to be guided safely and sensitively by left- and right-handed operators. Regardless of whether you prefer to sit or stand while working, the touch display is always at eye level and can be rotated and tilted as required. This ensures the measuring process is particularly comfortable and relaxed.

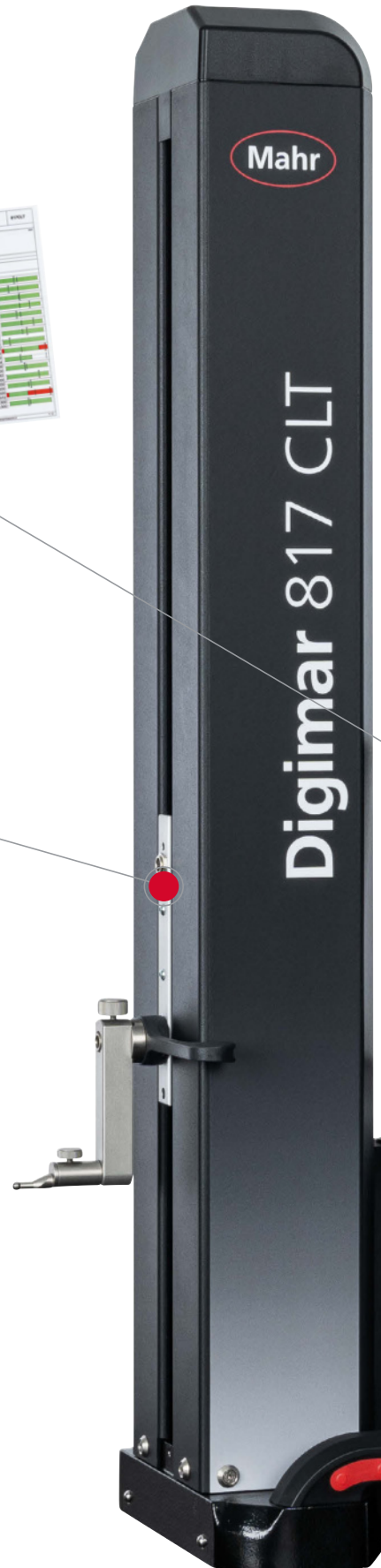



Simple touch measurement

Intuitive operation via large, clearly defined keys to ensure the safe completion on measurements, setting and calculation of functions, and the creation of measuring programs via Drag & Drop.

Pivoting display

10-inch touch panel with turn/tilt joint so that it can be set individually for the work position, height of the operator, and lighting conditions.



Easy handling

The thumbwheel can be used to move the measuring slide quickly and easily start the measurement. The quick measurement function keys also automatically detect surfaces and bores.



Best ergonomics

Ergonomic handles on both sides have an integrated operating key for the air bearing, ensuring the device can be moved accurately and effortlessly on the measuring plate.



FEATURES

- Contacting from below/above
 - Bar width or groove spacing including bar or groove center
 - Bore or shaft diameter including bore or shaft center
 - Reversal point bores (top or bottom)
 - Reversal point shaft (top or bottom)
 - Calculate distances or symmetry
 - Dynamic measurement functions
 - Right angle measurement
 - Straightness measurement
 - Measurement in 2D mode
 - Measurement programs
 - Measurement data processing
 - Large and clear touch display with backlight
 - Operator guidance via self-explanatory icons
 - Operator guidance in several languages
 - Possibility to set additional zero points on workpiece
 - Additional measuring device can be connected with MarConnect USB interface
 - Future-proof due to update capability
 - Automatic stand-by circuit
 - Adjustable auto-off function, without loss of measured values
 - Excellent measuring accuracy and reliability due to optical incremental measuring system with double reading head
 - Dynamic probe system for high repeatability
 - Air bearing system for easy, jerk-free displacement
 - Measuring head guided in precision ball bearings
 - Simple measuring sequences due to motorized measuring slide
 - Probe constant remains after switch-off
 - Integrated rechargeable battery with high operating time for mains-independent measuring
 - Temperature compensation with an integrated temperature sensor
- Software:** MarCom Professional free download: www.mahr.com/marcom (only for Mahr data cables and wireless systems with USB and RS-232 interface)
- **Data interface:** 3x USB 2.0, wireless
 - **Package contains:** height measuring instrument incl. operating and display unit, carrier 817h1, probe K6/51, setting block 817 eb, USB cable, instruction manual, power source, protection cover, calibration certificate



TECHNICAL DATA

| Order no. | 4429600 | 4429601 | 4429602 | |
|----------------------------------|---------|---|---------|---------|
| Type | 817 CLT | | | |
| Measuring range | mm | 0 –350 | 0 –600 | 0 –1000 |
| Measuring range | inch | 0 –14" | 0 –24" | 0 –40" |
| Application range from | mm | 170 | | |
| Application range up to | mm | 520 | 770 | 1170 |
| Resolution | mm | 0.0001, 0.0005, 0.001, 0.005, 0.01 | | |
| Resolution | inch | .001", .0005", .0001", .00005", .00001" | | |
| Error limit | µm | (1.8 + L/600) L in mm | | |
| Repeatability bores | µm | 1 | | |
| Repeatability planes | µm | 0.5 | | |
| Perpendicularity error | µm | 5 | | 10 |
| Operating time max. | h | 16 | | |
| Measuring force | N | 1.0 ± 0.2 N | | |
| Relative humidity non-condensing | % | 65 | | |
| Working temperature | °C | 20 | | |
| Operating temperature | °C | 10 –40 | | |
| Data interface | | 3x USB 2.0. wireless | | |
| Standard | | Factory standard | | |

| Order no. | a | b | c | d | e | f |
|-----------|----|-----|----|-----|------|------|
| | mm | mm | mm | mm | mm | mm |
| 4429600 | 89 | 278 | 77 | 255 | 688 | 356 |
| 4429601 | 89 | 278 | 77 | 255 | 938 | 610 |
| 4429602 | 89 | 278 | 77 | 255 | 1338 | 1016 |

ACCESSORIES

| Order no. | Description | Type |
|-----------|---|---------|
| 4102220 | Receiver for instruments with Integrated Wireless | i-Stick |
| 6910271 | Printer set for MarSurf M 310 and Digimar 817 CLT | DP-B1 |
| 4221525 | Surface plate made from granite, 1000 x 630 mm | 107 G |
| 4221573 | Open underframe with edge protection, 1000 x 630 mm | 107 Ug |
| 4221526 | Surface plate made from granite, 1200 x 800 mm | 107 G |
| 4221574 | Open underframe with edge protection, 1200 x 800 mm | 107 Ug |



i-Stick



107 G + 107 Ug



DP-B1



FEATURES

- Top or bottom contacting
- Web width or distances between grooves, including center of web or groove
- Bore or shaft diameter, including center of bore or shaft
- Bore reversing point (up or down)
- Shaft reversing point (up or down)
- Calculating distances or symmetry
- Dynamic measuring functions
- Measuring program
- Measuring data processing
- Easy to read backlit graphic LCD
- Clear function keys
- Language-neutral operator guidance with self-explanatory symbols
- Possible to set additional zero points
- Memory can store up to 99 measured values
- Excellent accuracy and reliability due to the optical incremental measurement system with the double reader head
- Dynamic probing system enabling high repeatability
- Air bearings system for light and smooth movement
- Precise measuring head on stainless steel guideways
- Motorized measuring carriage simplifies measurement runs
- Temperature compensation with an integrated temperature sensor
- Probe constant remains after the instrument is switched off
- Integrated rechargeable battery for power source independent measurement
- **Software:** MarCom Professional free download: www.mahr.com/marcom (only for Mahr data cables and wireless systems with USB and RS-232 interface)
- **Data interface:** Opto RS-232C, USB, wireless
- **Battery type:** Ni-Mh rechargeable battery
- **Package contains:** height measuring instrument incl. operating and display unit, carrier 817h1, probe K6/51, setting block 817 eb, instruction manual, power source, protection cover, calibration certificate



TECHNICAL DATA

| Order no. | 4429030 | | 4429031 |
|----------------------------------|-----------------------------|---------------------|---------|
| Type | 816 CL | | |
| Measuring range | mm | 0 –350 | 0 –600 |
| Measuring range | inch | 0 –14" | 0 –24" |
| Application range from | mm | 170 | |
| Application range up to | mm | 520 | 770 |
| Resolution | mm | 0.001, 0.01 | |
| Resolution | inch | .00005", .0001" | |
| Error limit | µm | (2.8+L/300) L in mm | |
| Repeatability bores | µm | 3 | |
| Repeatability planes | µm | 2 | |
| Perpendicularity error | µm | 15 | 20 |
| Operating time max. | h | 10 | |
| Measuring force | N | 1.0 ± 0.2 N | |
| Relative humidity non-condensing | % | 65 | |
| Working temperature | °C | 20 | |
| Operating temperature | °C | 10 –40 | |
| Product weight | kg | 25.00 | 30.00 |
| Data interface | Opto RS-232C, USB, wireless | | |
| Standard | Factory standard | | |

ACCESSORIES

| Order no. | Description | Type |
|-----------|---|----------|
| 4346023 | Data connection cable USB (2 m) | 2000 USB |
| 4346020 | Data connection cable RS232C (2 m) | 2000 r |
| 4102232 | Transmitter for e-Stick | 2000 e |
| 4102230 | e-Stick receiver | e-Stick |
| 4221526 | Surface plate made from granite, 1200 x 800 mm | 107 G |
| 4221574 | Open underframe with edge protection, 1200 x 800 mm | 107 Ug |
| 4221525 | Surface plate made from granite, 1000 x 630 mm | 107 G |
| 4221573 | Open underframe with edge protection, 1000 x 630 mm | 107 Ug |



107 G + 107 Ug

Digimar 817 ts1

Probe set

FEATURES

- Large accessory kit consisting of:
 - Depth probe
 - Carrier with extended holder
 - Disc measuring probe for grooves, etc.
 - Conical measuring probe
 - Cylindrical measuring probe
 - Holder for M2 dial test indicator measuring anvils
 - Carrier including 4 spherical probes with shaft holder $\varnothing 8$ mm
 - Plastic case
- Package contains: case

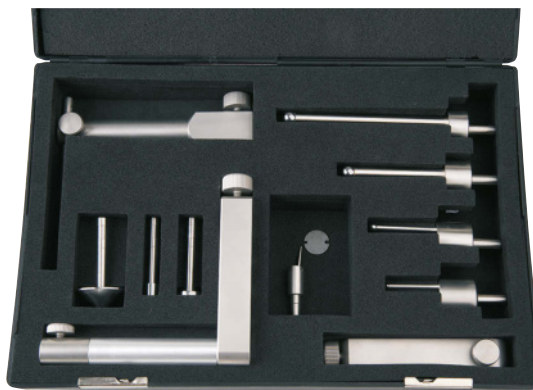

TECHNICAL DATA

| Order no. | Type |
|-----------|---------|
| 4429019 | 817 ts1 |

COMPONENTS INCLUDED IN SET

| Order no. | Description | Type |
|-----------|--|----------|
| 4429219 | Probe carriers, mounting hole 6 mm, a = 100.5 mm, b = 119.5 mm, c = 84 mm | 817 h2 |
| 4429226 | Disc probe $\varnothing 15$ mm | S15/31.2 |
| 4429227 | Cylindrical probe $\varnothing 10$ mm | Z10/31.2 |
| 4429228 | Taper probe | MKe 30 |
| 4429221 | Depth probe incl. holder | TMT 120 |
| 4429256 | Probe with M2 threads for 3 styli positions ($0^\circ/10^\circ/90^\circ$), incl. styli 800 ts $\varnothing 2.0$ mm | KM 2 |
| 4429220 | Probe carriers 817 CLM, mounting hole 8 mm | 817 h4 |
| 7023813 | Probe with mount, $\varnothing 4.0$ mm | K 4/30 |
| 7023816 | Probes with mount, $\varnothing 6$ mm | K 6/40 |
| 7023810 | Probes with mount, $\varnothing 10.0$ mm | K 10/60 |
| 7023615 | Probes with mount, $\varnothing 10.0$ mm | K 10/100 |

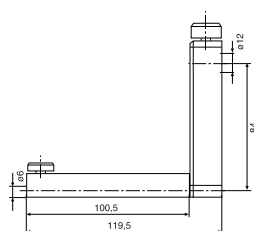

817 h2

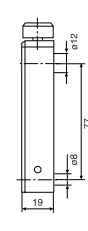

817 h4

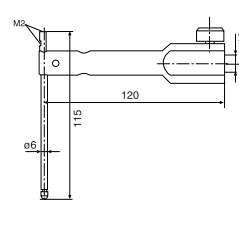

TMT 120

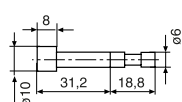

Z 10/31.2

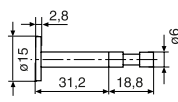

S 15/31.2

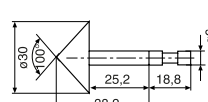

MKe 30

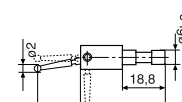

KM 2

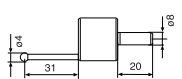

K 4/30

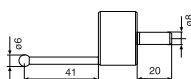

K 6/40

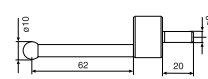

K 10/60

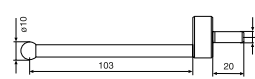

K 10/100

Digimar 817 ts2

Probe set

FEATURES

- Small accessory kit consisting of:
 - Depth probe
 - Carrier with extended holder
 - Disc measuring probe for grooves, etc.
 - Conical measuring probe
 - Cylindrical measuring probe
 - Holder for M2 dial test indicator measuring anvils
 - Plastic case
- Package contains: case

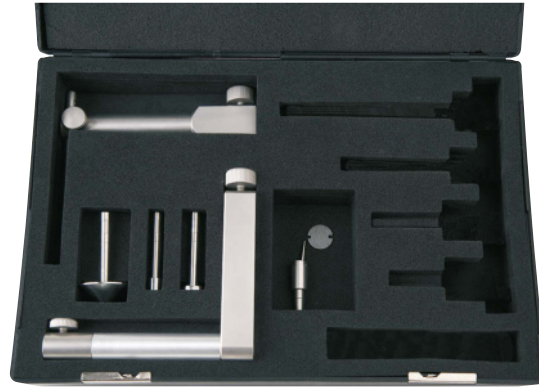

TECHNICAL DATA

| Order no. | Type |
|-----------|---------|
| 4429018 | 817 ts2 |

COMPONENTS INCLUDED IN SET

| Order no. | Description | Type |
|-----------|--|----------|
| 4429219 | Probe carriers, mounting hole 6 mm, a = 100.5 mm, b = 119.5 mm, c = 84 mm | 817 h2 |
| 4429226 | Disc probe \varnothing 15 mm | S15/31.2 |
| 4429227 | Cylindrical probe \varnothing 10 mm | Z10/31.2 |
| 4429228 | Taper probe | MKe 30 |
| 4429221 | Depth probe incl. holder | TMT 120 |
| 4429256 | Probe with M2 threads for 3 styli positions ($0^\circ/10^\circ/90^\circ$), incl. styli 800 ts \varnothing 2.0 mm | KM 2 |

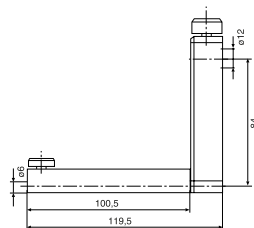

817 h2

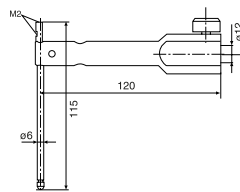

TMT 120

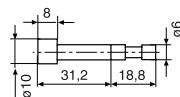

Z 10/31.2

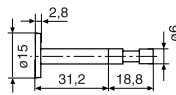

S 15/31.2

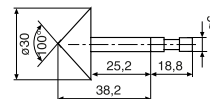

MKe 30

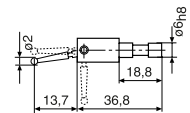

KM 2

Digimar 817 ts3

Universal probe set

FEATURES

- Accessory kit for small parts and delicate grooves, recesses and bores
- Suitable for 817 h4 carriers with 8 mm mounting bore
- Consisting of:
 - Base with 8 mm holding shaft
 - Depth probe
 - Probe shoe for grooves and recesses
 - Spherical measuring probe
 - Conical measuring probe
 - Extension
 - Adapter for M2.5 measuring anvils
 - Wooden case M2.5 measuring anvils
- Package contains: case

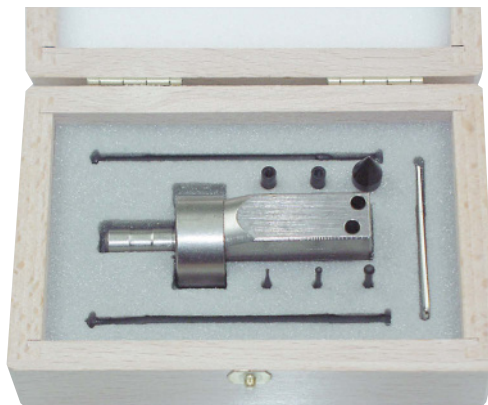

TECHNICAL DATA

| Order no. | Type |
|-----------|---------|
| 7034000 | 817 ts3 |

COMPONENTS INCLUDED IN SET

| Order no. | Description | Type |
|-----------|---|-----------|
| 3015918 | Measuring crook, $d = 0.5 \text{ mm}$, $l = 78 \text{ mm}$ | TS 0.5/78 |
| 3015919 | Probe pin/tip, $d = 1.2 \text{ mm}$, $l = 75 \text{ mm}$, $l_s = 15.5 \text{ mm}$ | T 1.2/75 |
| 3015920 | Taper probe | MKe 8 |
| 3022000 | Spherical probe, $d_k = 3.0 \text{ mm}$, $l = 24 \text{ mm}$ | K3/24 |
| 3022001 | Spherical probe, $d_k = 2.0 \text{ mm}$, $l = 24 \text{ mm}$ | K2/24 |
| 3022002 | Spherical probe, $d_k = 1.0 \text{ mm}$, $l = 24 \text{ mm}$ | K1/24 |
| 3015888 | Extension M3 - M2.5, $d = 4 \text{ mm}$, $l = 20 \text{ mm}$ | V/M2.5 |
| 3015921 | Extension M3 - M3, $d = 4 \text{ mm}$, $l = 20 \text{ mm}$ | V/M3 |
| 3015921 | Extension M3 - M3, $d = 4 \text{ mm}$, $l = 20 \text{ mm}$ | V/M 3 |

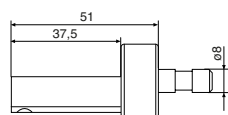

GK/8

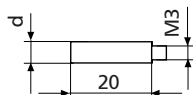

V/M2...M 3

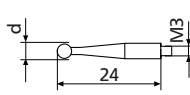

K 1...K3/24

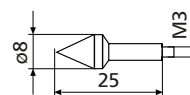

Mke 8

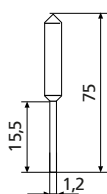

T 1.2/75

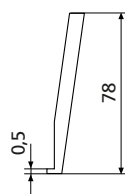

TS 0.5/78

Digimar 817 h1 / 817 h2 / 817 h5

Probe carriers

FEATURES

- Carrier for probes with 6 mm holding shaft
- Used for measurements at increased measuring depth (817 h2)
- Pivoting (817 h5) e.g. for aligning a cylindrical measuring probe



TECHNICAL DATA

| Order no. | Type |
|-----------|--------|
| 4429154 | 817 h1 |
| 4429219 | 817 h2 |
| 4429454 | 817 h5 |

| Order no. | a | b | c | Mounting hole |
|-----------|-------|-------|----|---------------|
| | mm | mm | mm | |
| 4429154 | 27.5 | 46.5 | 84 | 6 mm |
| 4429219 | 100.5 | 119.5 | 84 | 6 mm |
| 4429454 | 35 | 54 | 86 | 6 mm |

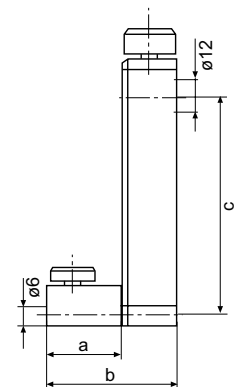

ACCESSORIES

| Order no. | Description | Type |
|-----------|--|----------|
| 4301865 | Mounting shaft \varnothing 6 mm | 800 a6 |
| 4429158 | Spherical probe, \varnothing 5.0 mm | K5/51 |
| 4429226 | Disc probe \varnothing 15 mm | S15/31.2 |
| 4429227 | Cylindrical probe \varnothing 10 mm | Z10/31.2 |
| 4429228 | Taper probe | MKe 30 |
| 4429254 | Spherical probe for 817 CLM, \varnothing 6 mm | K6/51 |
| 4429256 | Probe with M2 threads for 3 styli positions ($0^\circ/10^\circ/90^\circ$), incl. styli 800 ts \varnothing 2.0 mm | KM 2 |

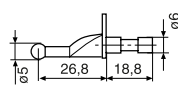

K 5/51

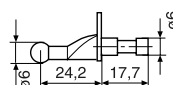

K 6/51

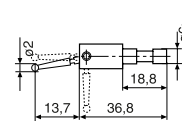

KM 2

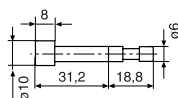

Z 10/31.2

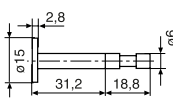

S 15/31.2

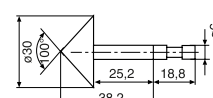

MKe 30

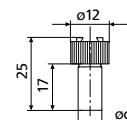

800 a6

Digimar 817 h4

Probe carriers

FEATURES

- Carrier for measuring anvils with 8 mm holding shaft and weighing 102 g
- Suitable for the CXt2 universal measuring probe set
- Compatible with Digimar CX1 and CX2 probes weighing 102 g



TECHNICAL DATA

| Order no. | Type | Mounting hole |
|-----------|--------|---------------|
| 4429220 | 817 h4 | 8 mm |

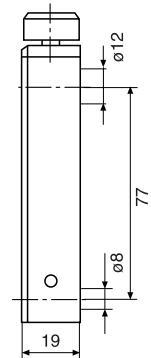

ACCESSORIES

| Order no. | Description | Type |
|-----------|---|-----------|
| 3015888 | Extension M3 - M2.5, d = 4 mm, l = 20 mm | V/M2.5 |
| 3015917 | Probe carrier | Gk/8 |
| 3015918 | Measuring crook, d = 0.5 mm, l = 78 mm | TS 0.5/78 |
| 3015919 | Probe pin/tip, d = 1.2 mm, l = 75 mm, ls = 15.5 mm | T 1.2/75 |
| 3015920 | Taper probe | MKe 8 |
| 3015921 | Extension M3 - M3, d = 4 mm, l = 20 mm | V/M3 |
| 3022000 | Spherical probe, d _k = 3.0 mm, l = 24 mm | K3/24 |
| 3022001 | Spherical probe, d _k = 2.0 mm, l = 24 mm | K2/24 |
| 3022002 | Spherical probe, d _k = 1.0 mm, l = 24 mm | K1/24 |
| 7023615 | Probes with mount, ø 10.0 mm | K 10/100 |
| 7023810 | Probes with mount, ø 10.0 mm | K 10/60 |
| 7023813 | Probe with mount, ø 4.0 mm | K 4/30 |
| 7023816 | Probes with mount, ø 6 mm | K 6/40 |

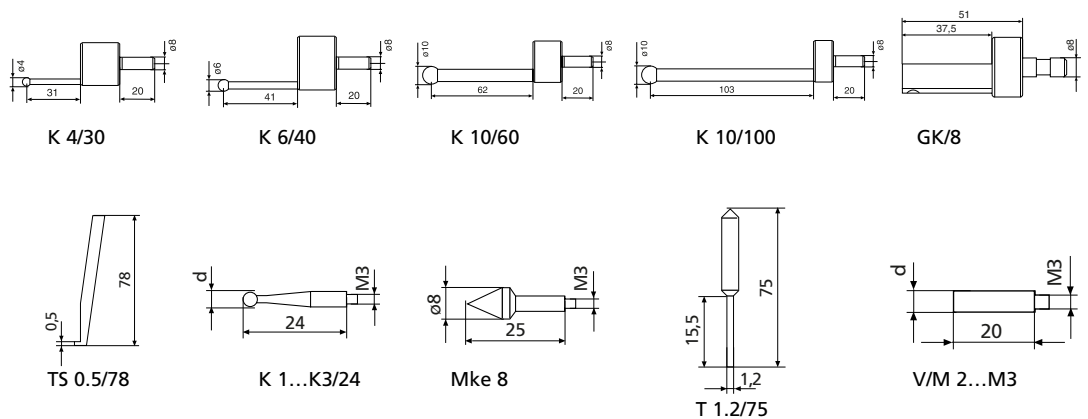

Digimar TMT 120 / TMT 120 S

Depth probe including holder

FEATURES

- Depth probe and carrier for measurements in vertical bores and recesses
- Interchangeable depth probe
- M2 and M2.5 connecting threads for measuring anvils
- M2.5 spherical contact point 901 H
- Pivatable (TMT 120 S only)
- Second depth probe with probe shoe for groove measurement (TMT 120 S only)
- M2 stylus 800 ts with 2 mm ball (TMT 120 S only)

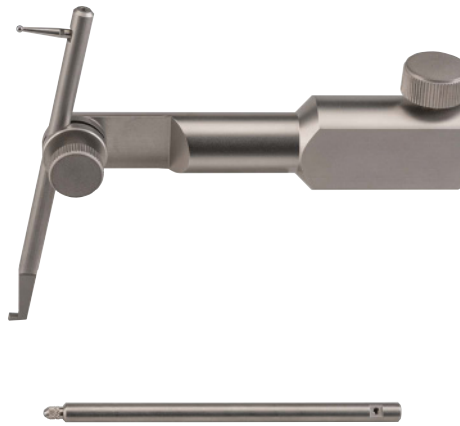

TECHNICAL DATA

| Order no. | Type |
|-----------|-----------|
| 4429221 | TMT 120 |
| 4429421 | TMT 120 S |

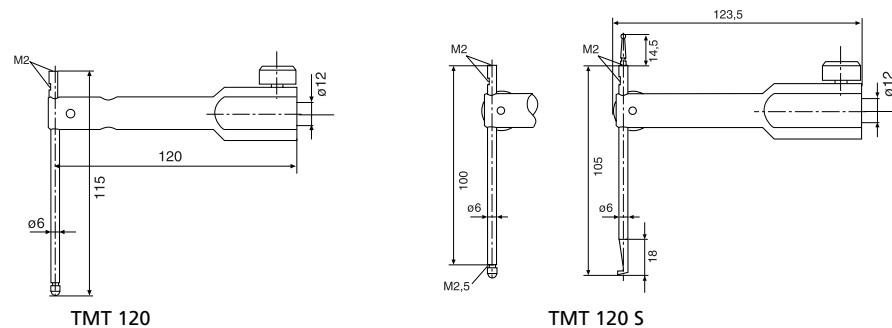

ACCESSORIES

| Order no. | Description | Type |
|-----------|---|---------|
| 4305870 | Stylus \varnothing 1.0 mm, carbide, $l = 14.5$ mm | 800 ts |
| 4305850 | Stylus \varnothing 2.0 mm, carbide, $l = 14.5$ mm | 800 ts |
| 4305871 | Stylus \varnothing 3.0 mm, carbide, $l = 14.5$ mm | 800 ts |
| 4309051 | Stylus \varnothing 2.0 mm, ruby, $l = 14.5$ mm | 800 tsr |
| 4360001 | Standard contact point, steel, $r = 1.5$ mm | 901 |
| 4360002 | Standard contact point, carbide, $r = 1.5$ mm | 901 H |
| 4360003 | Standard contact point, ruby, $r = 1.5$ mm | 901 R |
| 4360241 | Pin contact point, carbide, $l = 11$ mm, measuring surface \varnothing 1.5 mm | 911 H2 |

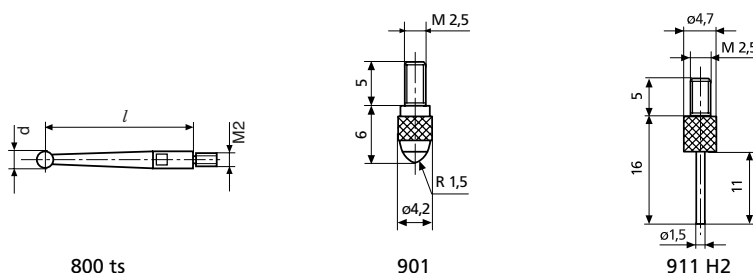

Digimar 817 h3

Carrier for checking perpendicularity

FEATURES

- Carrier for perpendicularity measurement
- Suitable for analog and digital dial indicators
- Ideal with P1514H measuring probe (817 CLM only)



TECHNICAL DATA

| Order no. | Type |
|-----------|--------|
| 4429206 | 817 h3 |

| Order no. | Mounting hole |
|-----------|---------------|
| 4429206 | 8 mm |

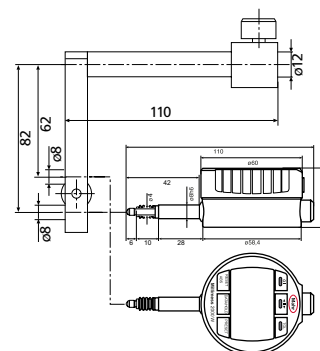

ACCESSORIES

| Order no. | Description | Type |
|-----------|--|--------|
| 4346700 | Inductive dial comparator, $\pm 1 \mu\text{m}$ | 2000 W |
| 4346800 | Inductive dial comparator, $\pm 1 \mu\text{m}$ | 2001 W |
| 4429610 | Data connection cable | DK-M1 |



2001 W



2000 W



DK-M1

Digimar 814 N

Height measuring and scribing instrument



FUNCTIONS

- ON/OFF
- RESET (set display to zero)
- mm/inch
- PRESET (for entering a numerical value)
- MAX/MIN memory for searching the reversal point
- (MAX-MIN) for testing flatness and concentricity
- TOL (enter tolerance limit values)
- Selectable resolution
- DATA (data transmission)

FEATURES

- Large, easy-to-read digital display
- Measuring and display unit are incorporated in the measuring head
- Data transmission via Opto RS232 C interface
- Digital preset
- Zero setting in any position
- MAX, MIN and MAX-MIN functions
- Enter tolerance limit for 1 characteristic
- Switch between mm/inch
- High accuracy
- Incremental inductive measuring system
- Measuring head with a ball bush guide
- Resistance free measuring system
- Easy to operate due to the hand crank on the side of the measuring head
- Constant measuring force; acting upwards or downwards as required
- Measuring head can be locked in position, ideal for scribing tasks
- With fine adjustment
- Power source independent due to being battery operated
- Universal application due to broad range of accessories
- **Data interface:** Opto RS-232C, wireless
- **Battery type:** CR 2032 (3V Lithium)
- **Package contains:** height measuring instrument incl. operating and display unit, caliper arm 814t, spherical probe 814 m, 8 mm, battery, instruction manual, protection cover, test certificate

Applications:

- For measuring heights and distances between bores, surfaces and edges
- For selecting and marking out workpieces



TECHNICAL DATA

| Order no. | 4426540 | 4426542 |
|------------------------|------------------------|----------|
| Type | 814 N | |
| Measuring range | mm 0 –320 | 0 –620 |
| Measuring range | inch 0 –12.6" | 0 –24.4" |
| Resolution | mm 0.001, 0.01 | |
| Resolution | inch .00005", .0005" | |
| Error limit | µm 20 | 30 |
| Perpendicularity error | µm 20 | 30 |
| Operating time max. | h 2000 | |
| Measuring force | N 3 | |
| Working temperature | °C 20 | |
| Operating temperature | °C 5 –40 | |
| Product weight | kg 6.20 | 10.50 |
| Data interface | Opto RS-232C, wireless | |
| Standard | Factory standard | |

ACCESSORIES

| Order no. | Description | Type |
|-----------|---|-----------|
| 4426510 | Probe arm 150 mm, mounting hole 8 mm | 814 t |
| 4426525 | Spherical probe, ball \varnothing 2.0 mm | 814 m |
| 4426526 | Spherical probe, ball \varnothing 3.0 mm | 814 m |
| 4426512 | Spherical probe, ball \varnothing 4.0 mm | 814 m |
| 4426527 | Spherical probe, ball \varnothing 5.0 mm | 814 m |
| 4426511 | Spherical probe, ball \varnothing 6.0 mm | 814 m |
| 4426528 | Spherical probe, ball \varnothing 7.0 mm | 814 m |
| 4426509 | Spherical probe, ball \varnothing 8.0 mm | 814 m |
| 4426498 | Spherical probe ruby ball, \varnothing = 4.0 mm | 817 CI-r |
| 4426513 | Disc probe | 814 s |
| 4426514 | Probe mount with connecting thread M2.5 | 814 h |
| 4426515 | Scriber for height gage 814 G | 814 a |
| 4426516 | Holder | 814 kh |
| 4426071 | Measuring taper 0–15 mm | 817 ks1 |
| 4426072 | Measuring taper 14–20 mm | 817 ks2 |
| 4426073 | Measuring taper 18–24 mm | 817 ks3 |
| 4426074 | Measuring taper 23–30 mm | 817 ks4 |
| 4426517 | Two direction probe, \varnothing = 4.0 mm | 814 u |
| 4426518 | Interchangeable probe arm, \varnothing = 2.0 mm | 814 ua |
| 4426434 | Holder with connection thread M2.5 / M1.6 / M1.4 | 817 CI-am |
| 4426433 | Stylus with exchangeable measuring pin | 817 CI-sa |
| 4426435 | Stylus with parallel measuring faces | 817 CI-p |
| 4426616 | Dust cover for 0–320 mm | |
| 4426619 | Dust cover for 0–620 mm | |
| 4102510 | Data connection cable RS232C (2 m) | 16 ESv |
| 4102235 | Transmitter for e-Stick | 1082 e |
| 4102230 | e-Stick receiver | e-Stick |
| 4102330 | Opto USB adapter cable RS232-USB (0.2 m) | Opto USB |

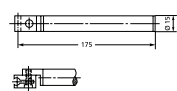

814 t

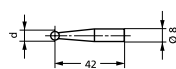

814 m

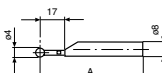

817 CI-r

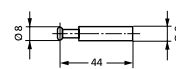

814 s

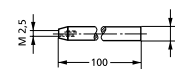

814 h

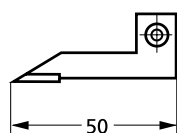

814 a

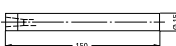

814 kh

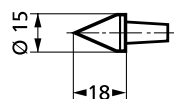

817 ks1

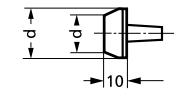

817 ks2;817
ks3;817 ks4

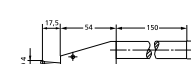

814 u

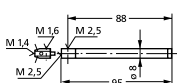

817 CI-am

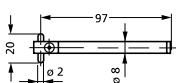

817 CI-sa

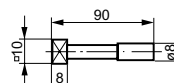

817 CI-p



e-Stick

Digimar 814 G

Height measuring and scribing instrument



FUNCTIONS

- ON/OFF
- RESET (set display to zero)
- mm/inch
- PRESET (for entering a numerical value)
- MAX/MIN memory for searching the reversal point
- (MAX-MIN) for testing flatness and concentricity
- TOL (enter tolerance limit values)
- Selectable resolution
- DATA (data transmission)

FEATURES

- Large, easy-to-read digital display
- Measuring and display unit are incorporated in the measuring head
- Data transmission via Opto RS232 C interface
- Digital preset
- Zero setting in any position
- MAX, MIN and MAX-MIN functions
- Enter tolerance limit for 1 characteristic
- Switch between mm/inch
- High accuracy
- Incremental inductive measuring system
- Measuring head with a ball bush guide
- Resistance free measuring system
- Easy to operate due to the hand crank on the side of the measuring head
- Constant measuring force; acting upwards or downwards as required
- Measuring head can be locked in position, ideal for scribing tasks
- With fine adjustment
- Power source independent due to being battery operated
- Universal application due to broad range of accessories
- **Data interface:** Opto RS-232C, wireless
- **Battery type:** CR 2032 (3V Lithium)
- **Package contains:** height measuring instrument incl. operating and display unit, caliper arm 814t, spherical probe 814 m, 8 mm, battery, instruction manual, protection cover, test certificate

Applications:

- For measuring heights and distances between bores, surfaces and edges
- For selecting and marking out workpieces



TECHNICAL DATA

| Order no. | 4426541 | 4426543 |
|------------------------|------------------------|----------|
| Type | 814 G | |
| Measuring range | mm 0 –320 | 0 –620 |
| Measuring range | inch 0 –12.6" | 0 –24.4" |
| Resolution | mm 0.001, 0.01 | |
| Resolution | inch .00005", .0005" | |
| Error limit | µm 20 | 30 |
| Perpendicularity error | µm 20 | 30 |
| Operating time max. | h 2000 | |
| Measuring force | N 3 | |
| Working temperature | °C 20 | |
| Operating temperature | °C 5 –40 | |
| Product weight | kg 14.00 | 18.30 |
| Plate size | mm 200 x 300 | |
| Data interface | Opto RS-232C, wireless | |
| Standard | Factory standard | |

ACCESSORIES

| Order no. | Description | Type |
|-----------|---|-----------|
| 4426510 | Probe arm 150 mm, mounting hole 8 mm | 814 t |
| 4426525 | Spherical probe, ball \varnothing 2.0 mm | 814 m |
| 4426526 | Spherical probe, ball \varnothing 3.0 mm | 814 m |
| 4426512 | Spherical probe, ball \varnothing 4.0 mm | 814 m |
| 4426527 | Spherical probe, ball \varnothing 5.0 mm | 814 m |
| 4426511 | Spherical probe, ball \varnothing 6.0 mm | 814 m |
| 4426528 | Spherical probe, ball \varnothing 7.0 mm | 814 m |
| 4426509 | Spherical probe, ball \varnothing 8.0 mm | 814 m |
| 4426498 | Spherical probe ruby ball, \varnothing = 4.0 mm | 817 CI-r |
| 4426513 | Disc probe | 814 s |
| 4426514 | Probe mount with connecting thread M2.5 | 814 h |
| 4426515 | Scriber for height gage 814 G | 814 a |
| 4426516 | Holder | 814 kh |
| 4426071 | Measuring taper 0–15 mm | 817 ks1 |
| 4426072 | Measuring taper 14–20 mm | 817 ks2 |
| 4426073 | Measuring taper 18–24 mm | 817 ks3 |
| 4426074 | Measuring taper 23–30 mm | 817 ks4 |
| 4426517 | Two direction probe, \varnothing = 4.0 mm | 814 u |
| 4426518 | Interchangeable probe arm, \varnothing = 2.0 mm | 814 ua |
| 4426434 | Holder with connection thread M2.5 / M1.6 / M1.4 | 817 CI-am |
| 4426433 | Stylus with exchangeable measuring pin | 817 CI-sa |
| 4426435 | Stylus with parallel measuring faces | 817 CI-p |
| 4426616 | Dust cover for 0–320 mm | |
| 4426619 | Dust cover for 0–620 mm | |
| 4102510 | Data connection cable RS232C (2 m) | 16 ESv |
| 4102235 | Transmitter for e-Stick | 1082 e |
| 4102230 | e-Stick receiver | e-Stick |
| 4102330 | Opto USB adapter cable RS232-USB (0.2 m) | Opto USB |

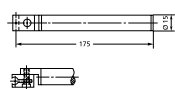

814 t

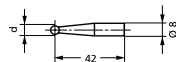

814 m

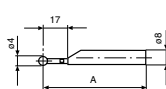

817 CI-r

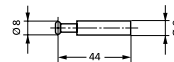

814 s

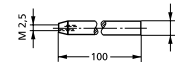

814 h

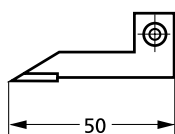

814 a

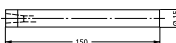

814 kh

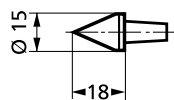

817 ks1

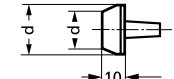

817 ks2;817 ks3;817 ks4

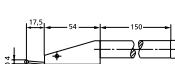

814 u

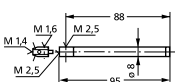

817 CI-am



817 CI-sa

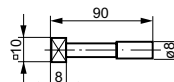

817 CI-p



e-Stick

Digimar 814 SR

Height measuring and scribing instrument



FUNCTIONS

- RESET (set display to zero)
- mm/inch
- ABS (switch between relative and absolute measurement)
- Lock/Unlock
- PRESET (for entering a numerical value)
- DATA (data transmission via connection cable)
- AUTO-ON / OFF

FEATURES

- Battery life up to 3 years
- Travel speed 1.5 m/s (60"/s)
- MarConnect data output: optional
 - USB
 - OPTO RS232C
 - Digimatic
- High contrast 12 mm LCD display
- Sturdy, heavy-duty machine base
- Hardened and lapped contact surface which produces both a smooth and even movement
- Slide and rail are made of hardened stainless steel
- Handwheel for positioning and measuring
- Fine adjuster
- Locking screw
- Interchangeable measuring and scriber tips, carbide-tipped
- **Software:** MarCom Professional free download: www.mahr.com/marcom (only for Mahr data cables and wireless systems with USB and RS-232 interface)
- **Data interface:** Opto RS-232C, Digimatic, USB, wireless
- **Energy supply:** Battery life approximately 3 years
- **Battery type:** CR 2032 (3V Lithium)
- **Package contains:** scriber, battery, carton, instruction manual

Applications:

- Scribing and marking workpieces
- Measuring heights and distances



TECHNICAL DATA

| Order no. | 4426100 | 4426101 |
|-----------------------|--|---------|
| Type | 814 SR | |
| Measuring range | mm 0 – 350 | 0 – 600 |
| Measuring range | inch 0 – 14" | 0 – 24" |
| Resolution | mm 0.01 | |
| Resolution | inch .0005" | |
| Error limit | µm 40 | 50 |
| Operating time max. | h 4000 | |
| Operating temperature | °C 10 – 40 | |
| Product weight | kg 7.00 | 8.00 |
| Data interface | Opto RS-232C, Digimatic, USB, wireless | |
| Standard | Factory standard | |

| Order no. | a | b | c | d |
|-----------|----|-----|----|-----|
| | mm | mm | mm | mm |
| 4426100 | 62 | 180 | 35 | 580 |
| 4426101 | 62 | 180 | 35 | 835 |

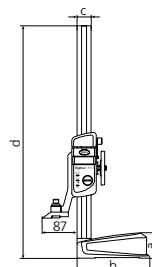

ACCESSORIES

| Order no. | Description | Type |
|-----------|---|---------|
| 4123867 | Measuring/scriber point, carbide tipped | 814 SRs |
| 4123041 | Holder for test indicators | 27 Sp |
| 4102357 | Data connection cable USB (2 m) | 16 EXu |
| 4102915 | Interface adapter with data cable Digimatic (2 m) | 16 EWd |
| 4102410 | Data connection cable RS232C (2 m) | 16 EXr |
| 4102230 | e-Stick receiver | e-Stick |
| 4102231 | Transmitter for e-Stick | 16 EWe |

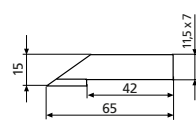

814 SRs; 27 ESh

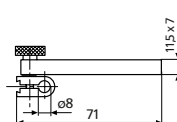

27 Sp



e-Stick



16 EWe

Precimar | Precision length metrology

Precimar stands for high-precision dimensional metrology – for both absolute and relative measurements. Typical applications include products and gages for the aerospace and automotive industries and the production testing of gages in calibration laboratories.



| | |
|--|------------|
| Precimar 826 PC Gage block testing | 492 |
| Precimar 130B-24 / 130B-16 Gage block testing | 493 |
| Precimar ICM 25 Dial indicator test device | 495 |
| Precimar ICM 100 IP Dial indicator test device | 498 |
| Precimar ICM 100 Dial indicator test device | 499 |
| Software and accessories | 500 |
| Precimar SM 60 Length measuring bench | 504 |
| Precimar LINEAR 800 / Linear 1200 / Linear 200 Length measuring device | 505 |
| Precimar ULM-E Calibration measuring instruments | 508 |
| Precimar ULM S-E Calibration measuring instruments | 509 |
| Precimar ULM L-E Calibration measuring instruments | 510 |
| Precimar PLM 600-E / 1000-E Precision length measuring machine | 514 |
| Precimar CiM 1000 CNC Precision length measuring machine | 515 |

Precimar 826 PC

Gage block comparator

FEATURES

The 826 PC gage block measuring instrument is quick, reliable and highly accurate. An open and extremely rigid L-shaped stand forms the base for the two counteracting precision measuring probes and the measuring table.

- C 1202 Amplifier with color display (110 mm / 4,3", 480 x 272 Pixel)
- Rigid cast stand for temperature stability and heat resistance
- Fast adjustment of vertical slide with top probe
- Highly ergonomic, user-friendly one-handed operation to position the gage blocks under the measuring probe
- Precision adjustment via torsionally rigid parallelogram springs
- Electropneumatic lifting of measuring probes
- Precision ball bearing guides for smooth manipulator actuation
- No influence on measurement from hand force
- Round carbide precision support pins make it easy to move the gage blocks on the measuring table
- Set value linked to the stored actual deviation of the reference gage block, avoiding the need for zero point setting
- With QM-Block software (accessory):
- Flattening correction
- Correction of differing coefficients of expansion
- Mean value generation
- **Data interface:** USB
- **Energy supply:** 230 V/115 V; 50/60 Hz
- **Package contains:** Display unit C 1202 + measuring module N 1702 VSS



Application:

- Quick and easy high precision testing of European and US gage blocks up to 170 mm in length, as per ISO 3650

TECHNICAL DATA

| Order no. | Type | Application range | Direct measuring range [mm] | Repeatability [μm] | Mass [kg] |
|-----------|--------|-------------------|-----------------------------|--------------------|-----------|
| | | mm | | | |
| 5350305 | 826 PC | 0.5 to 170 | 0.2 | ± 0.01 | 37 |

ACCESSORIES

| Order no. | Description | Type |
|------------|--|----------|
| 4102603 | Data cable USB bidirectional (2 m) | DK-U1 |
| 4102058 | Foot switch to trigger data transmission | 16 ESf |
| 9059092 | DELL® PC XE3/i5 SFF with WIN10 IoT int. | |
| 3027221 | 24" monitor | |
| 5350205 | QM-Block software | |
| 7023644 | Gage block vacuum lifting pad | |
| 4803335DKS | Parallel gage blocks made of carbide in set (11 pieces) incl. DAkkS calibration certificate for calibration of gage block test benches | 417-11/K |
| 4800130 | Gage block maintenance accessories | 424 |
| 4448010 | Heat shield made of acrylic glass | 826 Eg |
| 5355759 | Temperature measuring device Almemo 2590 for the temperature compensation in conjunction with the QM-Block software | |
| 5355162 | Temperature sensor for Almemo 2590 | |
| 9046377 | Gage block terminal for temperature sensor | |
| 5355756 | 230 V AC adapter for Almemo 2590 | |
| 5355757 | 120 V AC adapter for Almemo 2590 | |
| 5460029 | Laser printer A4 | |
| 3018232 | USB cable connection for printer | |



424

Precimar 130B–24 / 130B–16

Gage block comparator

FEATURES

The 130B–24 and 130B–16 gage block measuring instruments from Mahr are the first choice for many large calibration laboratories. They are designed for comparative measurements of gage blocks.

- A unique “floating measuring frame” ensures exact point-to-point measurement
- Single sensor design for minimal electronic noise
- Precision balanced system for optimum adjustment of measuring forces
- Integrated measuring software and user interface
- Built-in positioning device for reproducible measuring positions
- **Energy supply:** 230 V/115 V; 50/60 Hz
- **Package contains:** Desktop computer, Windows software for 130 B, guide slot 30 x 9 mm, guide slot 35 x 9 mm, guide slot square blocks (5 positions)



Application:

- Quick and easy high precision testing of European and US gage blocks

TECHNICAL DATA

| Order no. | Type | Application range | Direct measuring range [mm] | Repeatability [µm] | Mass [kg] |
|-----------|---------|-------------------|-----------------------------|--------------------|-----------|
| | | mm | | | |
| 2150076 | 130B–24 | 2.5 to 100 | ± 0.01 | 6σ < 0.025 | 100 |
| 2150080 | 130B–16 | 2.5 to 600 | ± 0.01 | 6σ < 0.025 | 140 |

ACCESSORIES

| Order no. | Description |
|-----------|---|
| 2238823 | Guide slot for gage blocks (4 positions) |
| 2238826 | Guide slot for cross-section 30 x 9 mm (test piece) and gage block (reference end dimension) |
| 2238825 | Guide slot for cross-section 35 x 9 mm (test piece) and gage block (reference end dimension) |
| 2240939 | Guide slot for gage block (test piece) and (reference end dimension) cross-section 30 x 9 mm |
| 2240940 | Guide slot for gage block (test piece) and (referenced dimension) cross-section 35 x 9 mm |
| 2243256 | Guide slot for cross-section 30 x 9 mm (test piece) and (reference end dimension) cross-section 30 x 9 mm |
| 2243257 | Guide slot for cross-section 35 x 9 mm (test piece) and (reference end dimension) cross-section 30 x 9 mm |
| 2253440 | Almemo temperature measurement device with 2 sensors |
| 2240602 | Accessory set for gage block test stand |
| 2260985 | Gage block set for the calibration of gage block test stands |

Precimar. Dial indicator testing

Partially and fully automated testing of indicating measuring equipment

Dial indicator test devices from Mahr stand for accurate and efficient measurement. These devices are designed for absolute measurement of dial indicators, dial comparators, dial test indicator measuring devices and 2-point bore gages as well as inductive and incremental measuring probes. Typical areas of use include dial indicator testing in all sectors of industry, measuring rooms and calibration laboratories as well as production testing by dial indicator manufacturers. When selecting the Precimar ICM dial gage testers, Mahr offers you practical solutions for both manual and fully automatic testing.

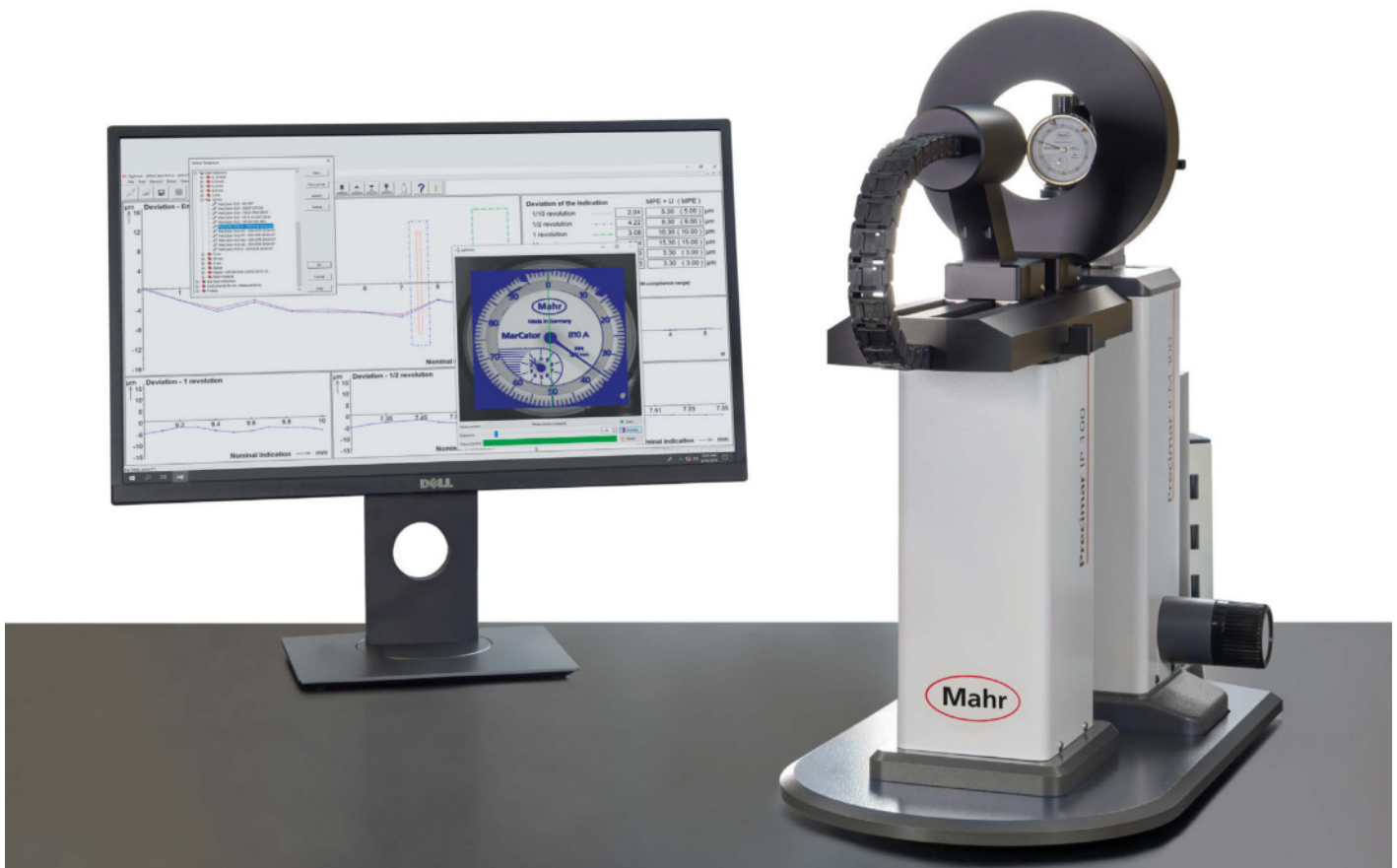

Precimar ICM 25

Manual dial indicator testing position

FEATURES

The Precimar ICM 25 is the most cost effective test station for manual testing of digital and dial indicators, dial test indicator measuring devices as well as inductive and incremental measuring probes.

- C 1202 amplifier with color display (110 mm / 4,3", 480 x 272 pixel)
- Fast height adjustment to adapt indicators according to the measuring range
- Rigid, box-shaped device housing
- For measuring objects with 8 mm, 3/8" shaft diameter
- All control elements are ergonomically arranged
- Complies with Ernst Abbe's comparator principle for maximum measuring accuracy
- **Energy supply:** 230 V/115 V; 50/60 Hz
- **Package contains:** display unit C 1202 + measuring module N 1702 VSS, split bushing BU-197, mounting shaft 800a3/8

Applications:

For testing of

- Dial indicators (analog and digital)
- Dial comparators (analog and digital)
- Dial test indicator measuring devices (analog and digital)
- Inductive and incremental probes



TECHNICAL DATA

| Order no. | Type | Measuring range | Measuring uncertainty MPE_{E1} (L in mm) [μm] |
|-----------|--------|-----------------|---|
| | | mm | |
| 2062722 | ICM 25 | 25 mm, 2 inch | ± 0.2 |

ACCESSORIES

| Order no. | Description | Type |
|-----------|--|--------|
| 4102058 | Foot switch to trigger data transmission | 16 ESf |
| 4102603 | Data cable USB bidirectional (2 m) | DK-U1 |
| 4305885 | Mounting shaft $\varnothing 4$ mm | 800 a4 |
| 4305893 | Universal centering support frame | 800 b |

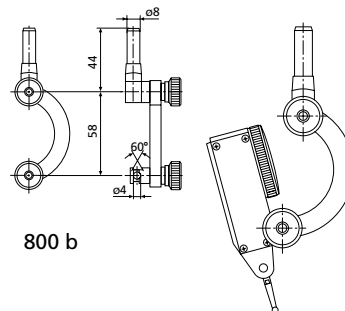
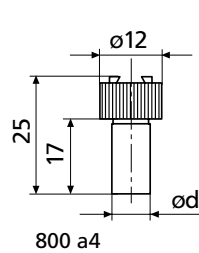

Fast and reliable results

The space-saving table-top unit is designed for simple operation and fast test procedures. Automated measuring significantly increases your efficiency. At the same time, the innovative, ergonomic design ensures that every movement is comfortable.

Fast and reliable data acquisition

The high-performance USB 3.0 camera and robust LED ring light guarantee that all display values are reliably detected. Even if the scale or digit display of your test object is not exactly in the center of the image, the system reads the display values without error.

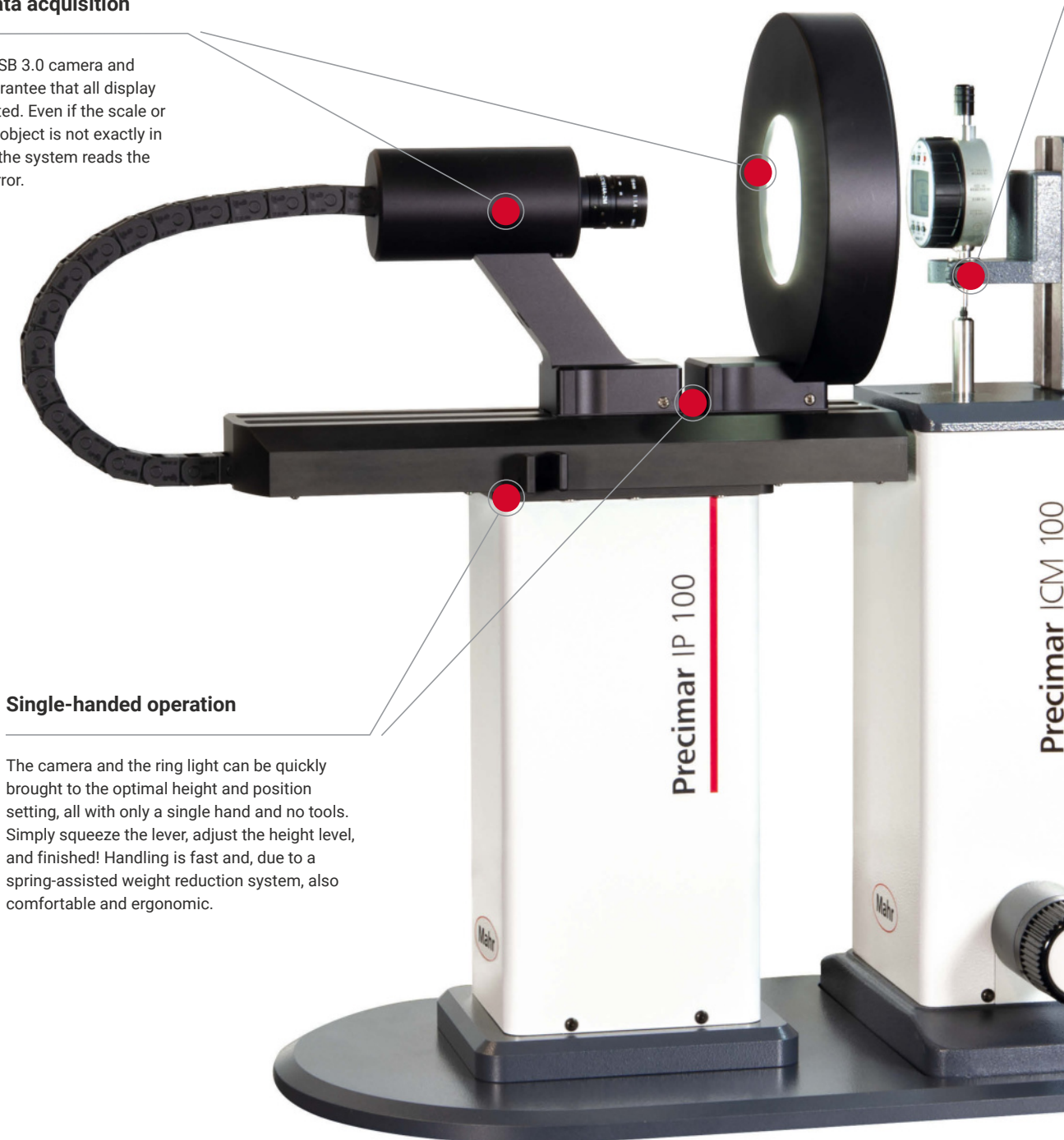

Single-handed operation

The camera and the ring light can be quickly brought to the optimal height and position setting, all with only a single hand and no tools. Simply squeeze the lever, adjust the height level, and finished! Handling is fast and, due to a spring-assisted weight reduction system, also comfortable and ergonomic.

Pre-loaded measurement modules

Measurement modules for more than 266 test specimens are pre-loaded into the software. Simply select a module during set-up based on the indicator you wish to measure. This saves time and reduces the risk of data entry errors. You can also create custom measurement modules or modify existing modules to fit your needs and requirements.

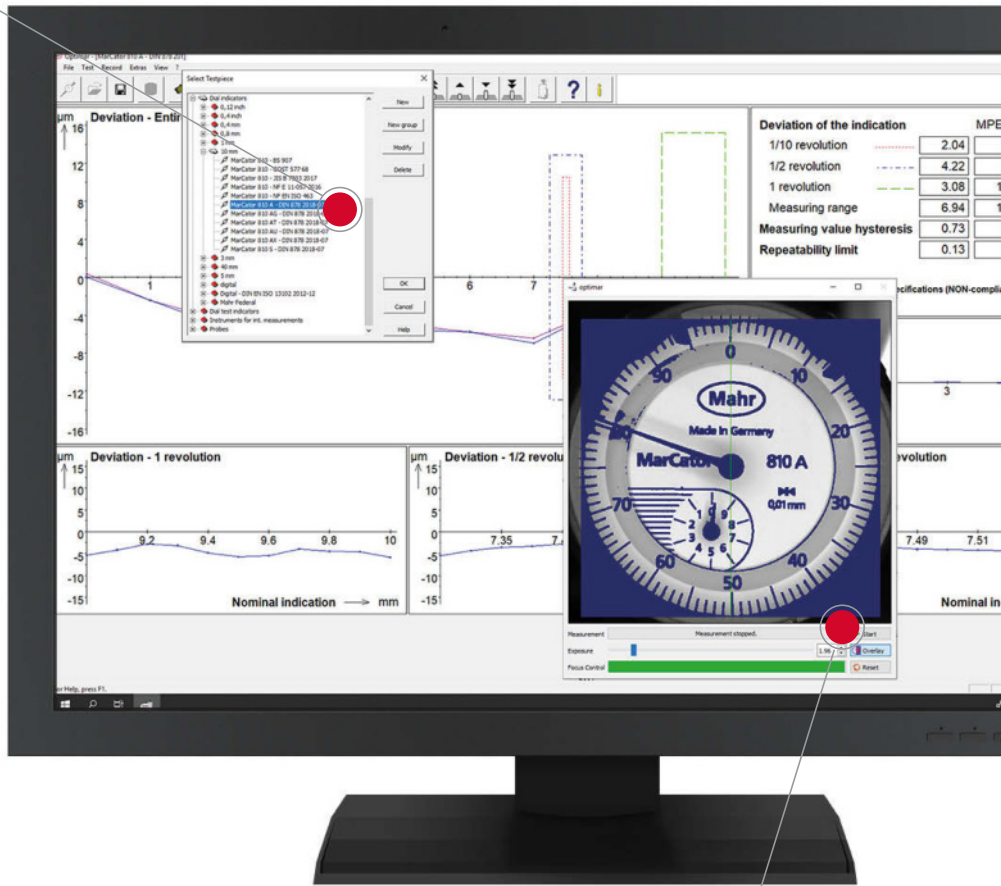

Improved specimen mounting

The bracket for mounting the test specimen exhibits improved clamping properties and easier handling. Specimens with shaft diameters of 8 mm, 28 mm, or 3/8" can be easily and securely mounted.

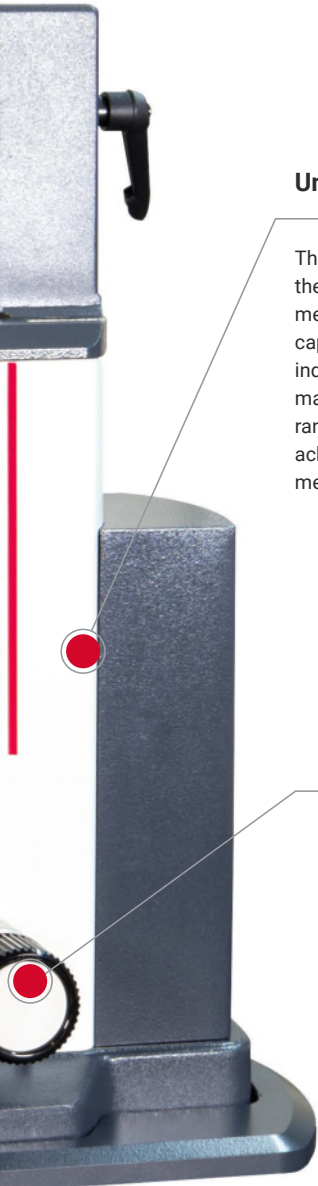

Universal and proven

The proven foundation of the ICM 100 IP is the ICM 100 (fka Optimar 100). This proven measurement solution is versatile in its capability to measure analog and digital indicators and comparators of different makes and models. With its measurement range of up to 4 inches / 100 mm, you will achieve standardized and traceable measurement results.

Easy setup

Ready to go in a few moments – due to software support with live visualization. You can see at a glance whether the camera is in focus and the exposure is sufficient. Real-time visual feedback ensures that each of your hand movements is right.

Manual mode

Would you prefer to measure certain indicators or comparators using a manual or semi-automated process? This is easily accomplished using the electronic handwheel. In manual or semi-automatic mode, the camera can be used as a magnifier. With the enlarged live-feed image, you can more easily read the dial face, thereby reducing eye strain and parallax error.

Precimar ICM 100 IP

Fully automated dial indicator test bench

FEATURES

You can use Precimar ICM 100 IP to automatically and cost-effectively test dial indicators and dial comparators. Easy handling with one hand and the clever software ensure the test device is the perfect solution for measuring rooms, calibration labs, and production testing. Testing measuring equipment has never been as efficient as with the Precimar ICM 100 IP: More than 60% time saved thanks to fast image processing, user-friendly software, and simple handling.



- Convenient, tool-free and intuitive operation with just one hand
- Highest-accuracy measurement through compliance with Abbe's principle
- Testing to international standards, including ASME/ANSI, DIN, BS, JIS, VDI, GOST and NF.
- High-performance USB 3.0 industrial camera with high image quality and wide dynamic range
- Robust, industrial-grade LED ring light for measurements unaffected by ambient light
- Ability to automatically measure digital indicators through direct reading of values – no cables required
- Wide variety of possible test specimens up to 4" inches / 100 mm – dial and digital indicators, comparators, test indicators
- Pre-programmed measurement modules with pre-loaded nominal values and tolerances
- Direct measurement range of 4 inches / 100 mm – no need to reposition the test specimen during testing
- Inductive probes from various manufacturers can be tested (only in manual mode)
- **Energy supply:** 230 V/115 V; 50/60 Hz
- **Package contains:** ICM IP software option, RS232C null modem cable, USB cable, support arm/clamp Ø12 mm, reduction clamping bushing Ø12 mm to Ø8 mm, power source, calibration certificate

Applications:

- Calibration of dial indicators, dial test indicator measuring devices and dial comparators
- The Precimar MSW 100 software system controls the dial indicator test device, processes the camera image (pointer or numeric display of the test object) and the reference measuring values of the dial indicator test device, and also performs all the subsequent processes related to test equipment management
- The testing routine can be implemented based on DIN, VDI, DKD or DAkkS guidelines, various international standards, or based on the company's internal specifications
- Deviations between test objects are illustrated in a graph during testing

TECHNICAL DATA

| Order no. | Type | Measuring range | Measuring uncertainty MPE_{E1} (L in mm) [µm] | Mass [kg] |
|-----------|------------|-----------------|--|-----------|
| 5351010 | ICM 100 IP | mm 100 mm | $\leq (0.2 + L/250)$ | 45 |

ACCESSORIES

| Order no. | Description | Type |
|-----------|---|---------|
| 3027221 | 24" monitor | |
| 9059092 | DELL PC XE3/i5 SFF with WIN10 IoT int. | |
| 5358001 | ICM100 software (V13), basic software | MSW 100 |
| 5460030 | Ink jet printer A4, letter size | |
| 5460029 | Laser printer A4 | |
| 3018232 | USB cable connection for printer | |
| 7023901 | Foot switch for the adoption of measuring values | |
| 7025703 | Holder for dial test indicator measuring devices incl. mounting attachment to calibrate both measuring directions | |
| 7011721 | Clamping bushing for Ø 3/8" clamping shafts | |
| 7011722 | Clamping bushing for Ø 10 mm clamping shafts | |
| 9043093 | Support arm for dial indicators and dial comparators with 30 mm clamping shaft | |
| 9043092 | Measuring force sensor for ICM 100 | |
| 9057923 | Extended column to reach 100 mm range, if measuring force sensor is used | |

Precimar ICM 100

Motorized dial indicator testing position

FEATURES

The Precimar ICM 100 is the most cost-effective test station for the partially or fully automated testing of dial indicators, dial comparators, dial test indicator measuring devices and 2 point bore gages, as well as inductive and incremental measuring probes.

- Automated sub-processes with motorized measuring spindle drive
- Fully automatic measuring procedure with digital measuring equipment
- Precimar ICM 100 is Suitable for horizontal use
- Fast height adjustment to adapt measuring objects to different measuring ranges
- Rigid, box-shaped device housing
- For measuring objects with 8 mm, 28 mm, 3/8" shaft diameter
- Electronic handwheel for manual control of spindle movement. The sensitivity of the electronic handwheel adjusts automatically to the testpiece resolution
- All operating elements are ergonomically arranged
- Complies with Ernst Abbe's comparator principle for maximum measuring accuracies
- Measuring system with error compensation
- Checking of 2-point inner measuring devices with no loss of accuracy
- Pre-positioning: automatic
- Fine positioning: electronic rotary knob
- **Energy supply:** 230 V/115 V; 50/60 Hz
- **Package contains:** RS232C null modem cable, USB cable, support arm/clamp Ø12 mm, reduction clamping bushing Ø12 mm to Ø8 mm, power source

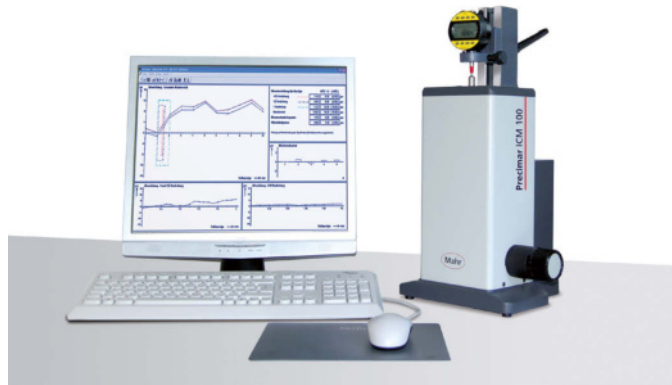

Applications:

For testing of

- Dial indicators (analog and digital)
- Dial comparators (analog and digital)
- Dial test indicator measuring devices (analog and digital)
- Inductive and incremental probes
- 2-point bore gages

TECHNICAL DATA

| Order no. | Type | Measuring range | Direct measuring range [mm] | Measuring uncertainty MPE _{E1} (L in mm) [µm] |
|-----------|---------|----------------------------------|-----------------------------|--|
| 5351005 | ICM 100 | mm 100 mm, 4 inch (101.66 mm) | 100 | ≤ (0.2 + L/250) |

ACCESSORIES

| Order no. | Description | Type |
|-----------|---|---------|
| 3027221 | 24" monitor | |
| 9059092 | DELL PC XE3/I5 SFF with WIN10 IoT int. | |
| 5358001 | ICM100 software (V13), basic software | MSW 100 |
| 5460030 | Ink jet printer A4, letter size | |
| 5460029 | Laser printer A4 | |
| 3018232 | USB cable connection for printer | |
| 7025703 | Holder for dial test indicator measuring devices incl. mounting attachment to calibrate both measuring directions | |
| 7011721 | Clamping bushing for Ø 3/8" clamping shafts | |
| 7011722 | Clamping bushing for Ø 10 mm clamping shafts | |
| 9043093 | Support arm for dial indicators and dial comparators with 30 mm clamping shaft | |
| 9043092 | Measuring force sensor for ICM 100 | |
| 9057923 | Extended column to reach 100 mm range, if measuring force sensor is used | |

Precimar MSW 100

Basic software (V13)

FEATURES

- Measurement/testing of dial indicators, dial comparators, dial test indicator measuring devices, and incremental/inductive probes
- Display of deviations curves/values
- Configurable testpiece template
- Preconfigured testpiece template for Mahr products
- Integration of DIN, VDI/VDE, JIS, ANSI, NF, and other standards and guidelines
- Individually adjustable records

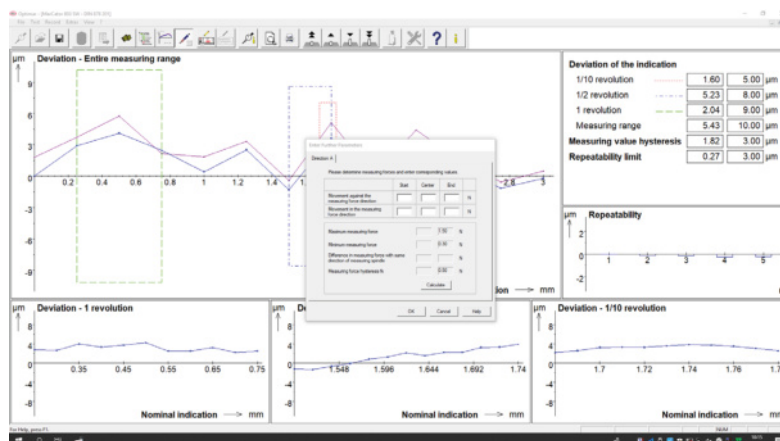

TECHNICAL DATA

| Order no. | Supported standards | Type |
|-----------|--|---------|
| 5358001 | <ul style="list-style-type: none"> • ASME B89.1.10M:2001 (Dial indicators, dial comparators, test indicators) • B.S. 907:2008 (Dial indicators) • B.S. 2795:1981 (Test indicators) • DIN 878:2018-06 (Dial indicators) • DIN 879:1999-06 (Dial comparators) • DIN 2270:2017-02 (Test indicators) • DIN EN ISO 463:2006-06 (Dial indicators) • DIN EN ISO 13102:2012-12 (Digital indicators) • DIN 32 876:1986-04 (Probes) • ISO 13102:2012-08 (Digital indicators) • JIS B 7503:2017 (Dial indicators) • JIS B 7519:1994 (Dial comparators) • NF EN ISO 463:2006-06 (Dial indicators) • NF E 11-056:2016-04 (Digital indicators) • NF E 11-057:2016-04 (Dial indicators und Dial comparators) • NF E 11-053:2013-10 (Test indicators) • GOST 577 68:01.07.68 (Dial indicators) • VDI/VDE/DGQ 2618 Part 11.1:2014-11 (Dial indicators) • VDI/VDE/DGQ/DKD 2618 Part 11.4:2019-08 draft (Digital indicators) | MSW 100 |

Precimar

Adapter for digital instruments und probes

FEATURES

- For the fully automated measurement of the testpiece
- Direct connection of the measuring equipment to the dial indicator test bench
- Measuring instrument interface is recognized automatically in the software

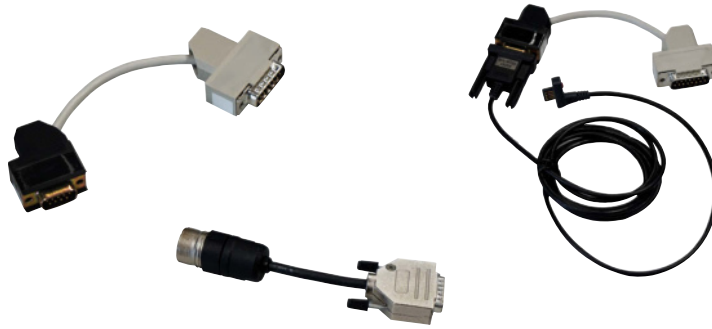

TECHNICAL DATA

| Order no. | For measuring instrument type | For measuring instrument | Data cable needed |
|-----------|--|---|---|
| 7023878 | Digital indicators | Mahr MarCator 1075/1075 R Mahr MarCator 1086/1086W/1086 R/ 1086 WR / 1086 Ri /1086 WRi Mahr MarCator 1087/1087 R /1087 Ri / 1087 BR / 1087 BRi | Mahr 16 EXr (Order no. 4102410) |
| 7023913 | Digital indicators | Mahr Millitast 1082 TESA DIGICO 10 Sylvac S229 / S213 | None |
| 7023909 | Digital indicators | Mahr Millitast 1083 / 1085 | None |
| 7025985 | Digital indicators and comparators | Mahr MarCator 1088 / 1088W Mahr MarCator μ Max μ m XL II Mahr Extramess 2000 / 2001 Mahr Millimes 2100 Mahr Millimes μ Max μ m II | Mahr 2000 r (Order no. 4346020) |
| 7052174 | Digital indicators and comparators | Mahr Federal μ Max μ m II / μ Max μ m XL II | None |
| 7046954 | Digital indicators | Mitutoyo Digimatic indicator | Digimatic data cable of manufacturer |
| 7033860 | Digital indicators and test indicators | Mahr Martest 800 EW / 800 EWL TESA DIGICO 12 TESA Tesatst IP 65 Sylvac S233 / Sylvac S234 Sylvac Series S_Dial | Mahr 800 EWr (Order no. 4305122) |
| 7046956 | Digital indicators | TESA DIGICO 205 / 305 / 400 / 500 / 600 /705 | RS232 Data cable of manufacturer |
| 7043260 | Digital indicators | Starrett indicator | Data cable of manufacturer |
| 7042301 | Digital indicators | Guanglu indicator | Data cable of manufacturer and Mahr RS232- cable (Order no. 7024634) |
| 7023897 | Digital amplifier | Mahr Millimar C1208 / C1216 / C1240 Mahr Millimar 1240 | Mahr RS232 cable (Order no. 7024634) |
| 7024082 | Incremental probes | Mahr Millimar 1512 / 1525 | None |
| 7034534 | Incremental probes | Heidenhain MT/ST 11 μ Ass w. M23-plug, 9-pin | None |
| 7044324 | Incremental probes | Mahr Millimar P1514 / P1526 Heidenhain MT/ST 1Vss w. M23-plug, 12-pin | None |
| 7044325 | Incremental probes | Mahr Millimar P1514H Heidenhain MT/ST 1Vss w. D-Sub-plug, 15-pin | None |
| 7051758 | Incremental probes | Heidenhain MT/ST TTL w. D-Sub-plug, 15-pin | None |
| 7034512 | Digital probes | Solartron Orbit DP1, DP2, LE12 | |
| 7053933 | Incremental probes | Keyence GT2 | Keyence cable connection Keyence RS232C communication unit DL-RS1A |

Precimar

Holder for 2-point inner measuring devices

FEATURES

- To secure inner measuring devices (up to max. measuring range of 100 mm and max. clamping diameter of 18 mm) during horizontal operation
- Automatic measurement in connection with software option, inductive probe 1340, and modules N1702 M-HR and N 1701 USB



TECHNICAL DATA

Order no.

5320021

ACCESSORIES

| Order no. | Type | Description |
|-----------|-------------|---|
| 5320026 | | Software option for 2-point inner measuring devices |
| 5331125 | N 1702 M-HR | Module for inductive probes |
| 5331130 | N 1701 USB | USB connecting module |
| 5313400 | 1340 | Inductive probe, ± 2 mm |



N 1702 M-HR



N 1701 USB



1340

Precimar. Length measurement for all areas of use

Length measurement is used today in all sorts of different sectors. LINEAR length measuring instruments are setting and measuring instruments designed for general workshop use. The well-established universal length measuring instruments (ULM) are standard instruments for quality assurance in calibration measurement. They are also used for highly accurate length measurements on precision parts. Motorized PLM and CiM instruments offer fast, reliable and user friendly measurement with the lowest possible uncertainty. With products ranging from the simple LINEAR length measuring instrument and the ULM devices to the ultra accurate, partially automated CiM universal measuring machine, Mahr has practical solutions for manufacturing, measuring rooms and calibration laboratories. Precimar offers maximum precision combined with extremely efficient measuring processes.

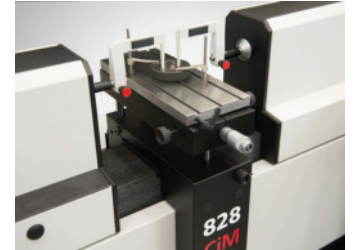

Precimar SM 60

Length measuring bench

FEATURES

The Precimar SM 60 is a user-friendly measuring instrument for fast, precise outside measurements on workpieces.

- Simple instrument design
- Quick adaptation to new workpieces
- Rugged construction makes it suitable for use close to production
- Freely selectable measuring equipment (e.g. digital dial indicator, measuring probes, etc.)
- Carbide measuring surfaces
- Integrated coupling protects the measuring equipment
- Wide choice of measuring attachments
- Suitable for left- and right-handed operators
- Large support table, Ø 60 mm, with variable height adjustment



TECHNICAL DATA

| Order no. | 5357360 | 5357370 |
|-----------------------------------|---------|---|
| Type | SM 60 | SM 60 |
| Mounting shaft diameter | mm | 8 |
| Application range | mm | 0 – 60 |
| Measuring range | mm | 0 – 25 mm |
| Measuring surface ø | mm | 6 |
| Parallelism of measuring surfaces | | <0.001 mm |
| Size of table | mm | Ø 60 |
| Direct measuring range | mm | 25 |
| Measuring forces | N | 1 N + measuring force of measuring system |
| | | 5 N + measuring force of measuring system |
| Mass | kg | 9 |

| Order no. | Height | Length | Width |
|-----------|--------|--------|-------|
| | mm | mm | mm |
| 5357360 | 120 | 290 | 140 |
| 5357370 | 120 | 290 | 140 |

ACCESSORIES

| Order no. | g | Description | Type |
|-----------|-------|---|---------|
| 4337661 | | Digital indicator, 0.0005 mm, 25 mm | 1087 R |
| 4337665 | | Digital indicator, 0.0005 mm, 25 mm | 1087 Ri |
| 4337621 | | Digital indicator, 0.0005 mm, 25 mm | 1086 R |
| 4337625 | | Digital indicator, 0.0005 mm, 25 mm | 1086 Ri |
| 5312010 | | Compact amplifier | C 1200 |
| 5323010 | M 2.5 | Inductive probe, ± 2 mm | P2004 M |
| 5355368 | | Measuring attachment M 2.5 | |
| 5355410 | | Measuring attachment with plane surface Ø 2 mm | |
| 5355411 | | Measuring attachment with flat-edged blade 2 | |
| 5355412 | | Measuring attachment with ball zone R20 | |
| 5355413 | | Measuring attachment with flat-edged blade 8 (pair) | |
| 5355414 | | Measuring attachment with plane surface Ø 8 mm | |
| 5355415 | | Measuring attachment with plane surface Ø 14 mm | |
| 5355416 | | Measuring attachment with plane surface Ø 7.5 mm | |
| 5355485 | | Measuring attachment with plane surface Ø 6.35 mm | |



1087 Ri



1086 R-HR;
1086 R; 1086 ZR



C 1200



P2004 U; P2004 T;
P2004 M; P2004 F;
P2004

Precimar Linear 800 / Linear 1200 / Linear 2000

Setting and measuring instrument

FEATURES

LINEAR length measuring instruments from Mahr are ideal for use as a setting and adjusting instrument close to the production area. They offer precision setting of inside and outside comparative measuring instruments, inside micrometers, 2-point bore gages, dial comparator snap gages and many other measuring instruments. As an infinitely adjustable dimensional standard, the LINEAR is a cost effective alternative to setting gages, adjustment rings and gage blocks.

Key advantages include the ease of handling, short set-up time and ability to set any dimension. A switchable measuring force regulator, for both outside and inside measurements, delivers user independent measuring results.

- Base bar made of steel alloy, providing the same thermal behavior as the setting and measuring objects
- Precision ground and lapped guide rail, non-rusting
- Glued on steel scale along entire length of base bar
- Easy to operate
- Precision adjustable to 1/10 µm
- Measured values displayed with MarCheck:
- Display unit with extensive measuring functions, USB connection for printer or stick and USB connection and RS232 interface for transfer to PC
- A factory calibration or DAkkS/ DKD calibration is available for the measuring station
- **Energy supply:** 230 V/115 V; 50/60 Hz
- Accessories
- Testing devices for outside micrometers
- Clamping devices for 2-point bore gages for universal measuring table
- Support for large, 2-point bore gages and their accurate positioning and setup on the LINEAR
- Adjustable height support for setting up large bore gages
- Support plates for rings > 200 mm
- Holding device for long measuring equipment
- Attachment for dial comparator snap gages (height-adjustable)
- Height measuring system for universal measuring table
- Additional support table for long measuring objects
- Measuring anvils with Ø 20 mm balls; with ball-ended gage

TECHNICAL DATA

| Order no. | 5357302 | 5357303 | 5357304 | |
|--|--------------|------------------|-------------|-------------|
| Type | Linear 800 | Linear 1200 | Linear 2000 | |
| Measuring range for outer measurement | mm 0 to 815 | 0 to 1215 | 0 to 2015 | |
| Measuring range for inner measurement | mm 40 to 855 | 40 to 1255 | 40 to 2055 | |
| Measuring uncertainty MPE_{E1} (L in mm) | µm | ≤ (0.7 + L/1000) | | |
| Repeatability | µm | ≤ 0.5 | | |
| Measuring forces | N | 3 | | |
| Mass | kg | approx. 155 | approx. 210 | approx. 320 |

| Order no. | Width | Hö Height he | Length |
|-----------|-------|--------------|--------|
| | mm | mm | mm |
| 5357302 | 240 | 460 | 1250 |
| 5357303 | 240 | 460 | 1650 |
| 5357304 | 240 | 460 | 2450 |

- blocks; with Ø 15 mm and Ø 7.5 mm spindles
- Caliper, bore gages, plug-on heads, clamping elements
- Testing setups for depth gages
- Support for inside micrometers
- Temperature compensation

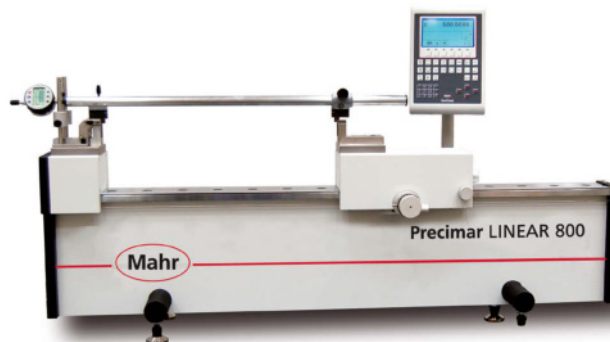

Applications:

- Setting comparative measuring instruments, e.g. Multimar 844 T
- Setting 2-point bore gages, e.g. Intramess 844 N
- Setting dial comparator snap gages, e.g. MaraMeter 840 F
- Checking and setting outer micrometers
- Checking setting standards, rods etc.
- Checking calipers
- Checking and setting inside micrometers
- Measuring cylindrical parts
- Measuring inner dimensions and bores, etc.

Length measuring instruments for calibration metrology

The well-established ULM universal length measuring instruments are standard quality assurance instruments in industrial manufacturing environments and reference instruments for gage and test equipment calibration. They are used for high-precision length measurements on precision parts such as gears, journals, ball hubs, ball cages, ball rings, tapers, gear shafts etc. and for checking gages and test equipment. These instruments are available for several measuring ranges (300 mm to 1500 mm/11.81 in to 59 in), in various accuracy classes (0.3 μm or 0.09 μm / 11.8 μin to 3.5 μin) and with the measuring system arranged in a number of different ways (in the measuring element or base or as a laser). This means that the right measuring instrument can be selected for each and every application. The varied sets of accessories and components are available as modules which also enables subsequent instrument additions.

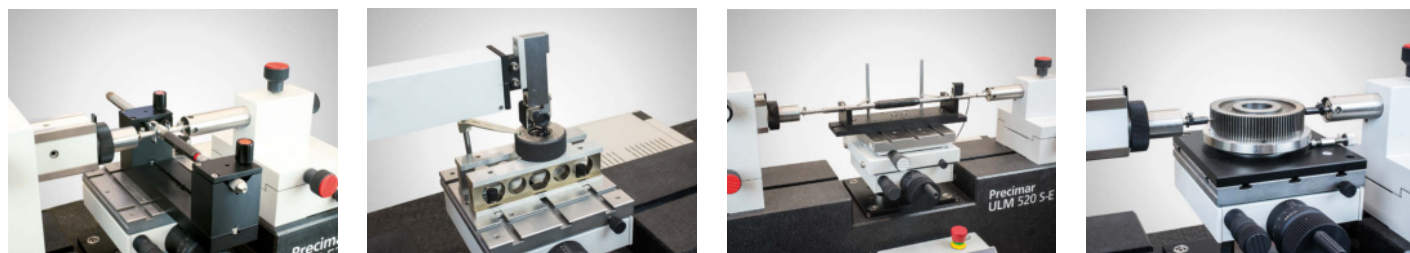

Precimar | Length measuring devices ULM-E series

Powerful Windows software

Maximum ease of use; inner thread measurement supported by automatic Z positioning

Wide range of accessories

Compatible with measuring tasks due to specifically configured accessory sets and individual components

Laser measuring system (ULM L-E variant)

Wide direct measuring range with maximum measuring accuracy

Online temperature monitoring

Correction of the different expansion behaviors and instrument zero-point stabilizing (patented) of the materials used as well as correction of systematic measuring errors due to temperature fluctuations of measuring object and setting standard

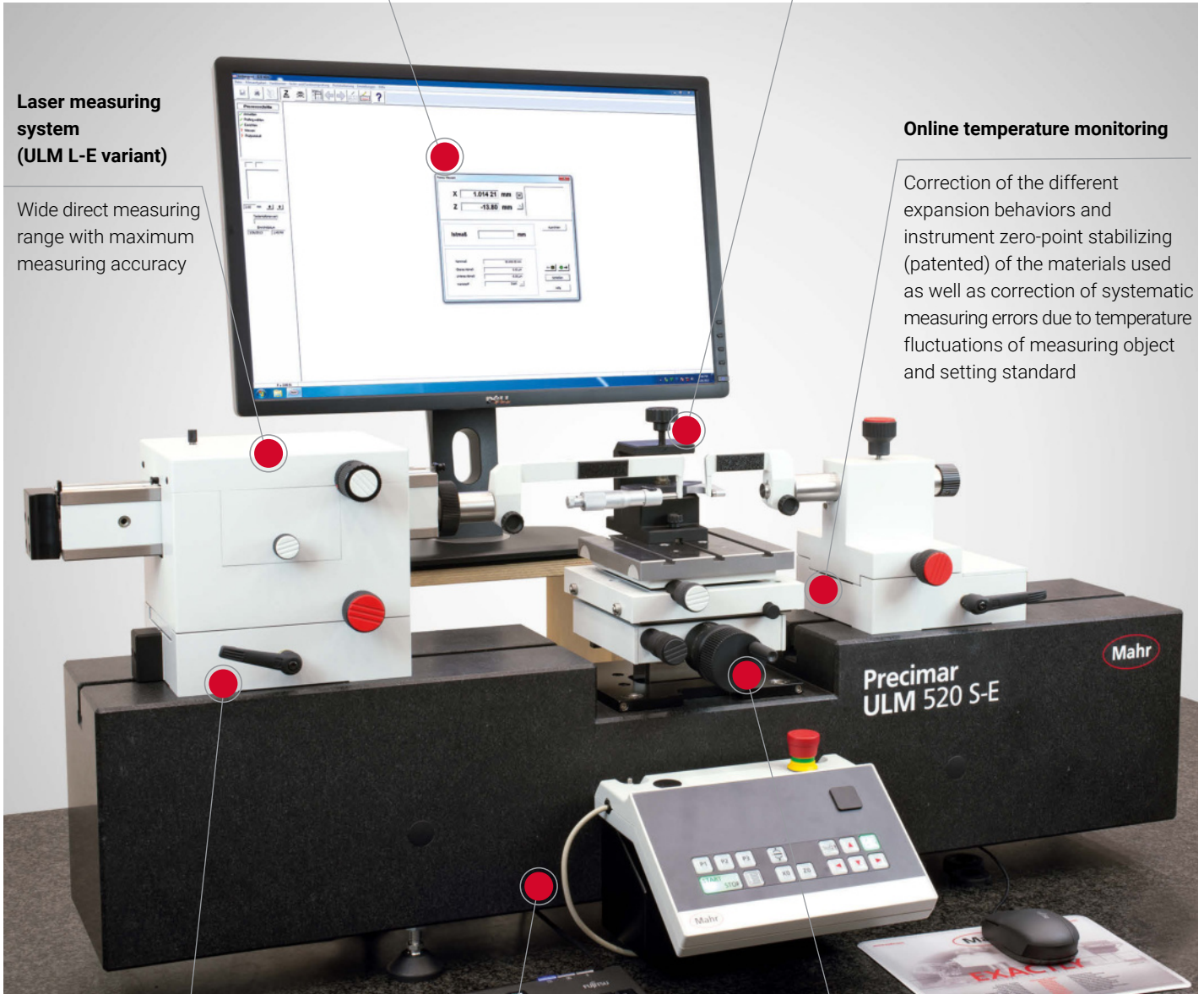

Air bearing

Productivity gain due to quick movement of ABBE measuring element and counter bearing

Granite

Highly homogenous and rigid

Z measuring system

Productivity gain and enabling of 2D measuring procedure by incorporating Z position values and travel paths

Precimar ULM 300-E / ULM 600-E / ULM 1000-E / ULM 1500-E

Calibration measuring instruments

FEATURES

ULM-E universal length measuring comparator instruments are mounted on highly homogeneous rigid granite in a horizontal configuration.

X-axis measuring system:

Heidenhain incremental, precision length measuring system, 100 mm long

Z-axis measuring system:

Renishaw incremental, precision length measuring system, 80 mm long



- High measuring accuracy
- Compliant with Ernst Abbe's comparator principle
- Manual operation of measuring spindle
- Air bearings for smooth manual positioning of measuring element and counter bearing (not ULM 300-E)
- Object table height adjustment via pushbuttons (also positioning of predefined increments)
- Computer provided temperature measurement with 2 or 3 sensors
- Computer-aided correction of systematic instrument errors (CAA)
- Computer-aided instrument zero point stabilizing
- Computer-aided correction of temperature and measuring force influences
- Constant measuring force over the entire measuring spindle setting range
- Large object table with precision guidance in the Z direction and a loading capacity of 25 kg
- Automatic reversing point detection with static and dynamic adoption of measuring values
- Inner thread measurement supported by automatic Z positioning
- Highly flexible in application range
- Mahr 828 WIN measuring and evaluation software runs under MS Windows®
- Optional use of measuring axis extensions
- **Energy supply:** 230 V/115 V; 50/60 Hz

ACCESSORIES

- Large number of accessory kits and modular components for completing a wide variety of measuring tasks, including the measurement of:
 - Thread gages
 - Taper gages
 - Conical thread gages
 - Gears
- Factory calibration or DAkkS/DKD calibration can be additionally offered for this measuring station

TECHNICAL DATA

| Order no. | | 5350258 | 5350260 | 5350262 | 5350266 |
|--|---------------|-----------------------|------------|------------|-------------|
| Type | | ULM 300-E | ULM 600-E | ULM 1000-E | ULM 1500-E |
| Direct measuring range | mm | 100 | | | |
| Measuring range for outer measurement | mm | 0 to 305 | 0 to 640 | 0 to 1060 | 0 to 1560 |
| Measuring range for inner measurement | mm | 0.5 to 150 | 0.5 to 485 | 0.5 to 905 | 0.5 to 1405 |
| Measuring uncertainty MPE_{E1} (L in mm) | μm | $\leq (0,09+L/2000)$ | | | |
| Repeatability | μm | $\leq 0,05$ | | | |
| Measuring forces | N | 0.2 ; 1.0 to 4.5 ; 11 | | | |
| Mass | kg | 110 | 160 | 215 | 280 |

| Order no. | Width | Height | Length |
|-----------|-------|--------|--------|
| | mm | mm | mm |
| 5350258 | 280 | 480 | 685 |
| 5350260 | 380 | 480 | 1080 |
| 5350262 | 380 | 480 | 1500 |
| 5350266 | 380 | 480 | 2000 |

Applications:

Calibration of

- Plain plug gages and gage rings
- Setting gage rings
- Snap gages
- Spherical gage blocks, internal micrometers
- Gage blocks
- Thread gages
- Taper thread gages
- Gear gages
- Taper gages
- Dial indicators
- Dial comparators
- 2-point bore gages
- Outside micrometers
- 2-point inside micrometers
- Length measurement on precision table



For more information, please visit our website: www.mahr.com

Precimar ULM 520 S-E / ULM 1000 S-E

Calibration measuring instruments

FEATURES

Large universal length measuring instruments with large direct measuring range are mounted on highly homogeneous rigid granite in a horizontal configuration
X-axis measuring system:

- Heidenhain incremental, precision length measuring system, 100 mm long in measuring element
- Heidenhain incremental incident light measuring systems covering the entire length of the base bed and to its right and left
- **Z-axis measuring system:** Renishaw incremental, precision length measuring system, 80 mm long
- Combined measuring instrument for ultra accurate measurements in the range to 100 mm and for measurements in the standard accuracy range
- Accurate throughout the entire movement range of the measuring element and counter bearing
- Recommended for measurements of larger measuring objects, but also suitable for measurements of smaller measuring objects
- Manual operation of measuring spindle
- Air bearings for smooth manual positioning of measuring element and counter bearing
- Object height adjustment via pushbuttons (also positioning of predefined increment)
- Computer provided temperature measurement with 3 sensors
- Computer-aided instrument zero point stabilizing and correction of systematic instrument errors (CAA)
- Constant measuring force over the entire measuring spindle setting range
- Computer-aided correction of temperature and measuring force influences
- Large object table with precision guidance in the Z direction and a loading capacity of 25 kg
- Mahr 828 WIN measuring and evaluation software runs under MS Windows®
- Optional use of measuring axis extensions
- Inner thread measurement supported by automatic Z positioning
- **Energy supply:** 230 V/115 V; 50/60 Hz



TECHNICAL DATA

| Order no. | | 5350267 | 5350268 |
|--|---------------|---|---|
| Type | | ULM 520 S-E | ULM 1000 S-E |
| Direct measuring range | mm | Outer measurement: 0 to 520 Inner measurement: 0.5 to 365 | Outer measurement: 0 to 1025 Inner measurement: 0.5 to 870 |
| Measuring range for outer measurement | mm | 0 to 520 | 0 to 1025 |
| Measuring range for inner measurement | mm | 0.5 to 365 | 0.5 to 870 |
| Measuring uncertainty MPE_{E1} (L in mm) | μm | only with ABBE measuring element: $MPE_{E1} \leq (0.09+L/2000)$ with base bed measuring system: $MPE_{E1} \leq (0.6+L/1000)$ | |
| Repeatability | μm | With Abbe measuring element: ≤ 0.05 With base bed measuring system: ≤ 0.2 | |
| Measuring forces | N | 0.2 ; 1.0 to 4.5 ; 11 | |
| Mass | kg | 160 | 215 |

| Order no. | Width | Height | Length |
|-----------|-------|--------|--------|
| | mm | mm | mm |
| 5350267 | 380 | 480 | 1080 |
| 5350268 | 380 | 480 | 1500 |

ACCESSORIES

- Large number of accessory kits and modular components for completing a wide variety of measuring tasks, including the measurement of:
 - Thread gages
 - Taper gages
 - Conical thread gages
 - Gears
- Factory calibration or DAKKS/DKD calibration can be additionally offered for this measuring station

Applications:

Calibration of

- Plain plug gages and gage rings
- Setting gage rings
- Snap gages
- Spherical gage blocks, internal micrometers
- Gage blocks
- Thread gages
- Taper thread gages
- Gear gages
- Taper gages
- Dial indicators
- Dial comparators
- 2-point bore gages
- Outside micrometers
- 2-point inside micrometers



For more information, please visit our website: www.mahr.com

Precimar ULM 800 L-E / ULM 1500 L-E

Calibration measuring instruments

FEATURES

Universal length measuring instruments with laser measuring system are mounted on highly homogeneous rigid granite in a horizontal configuration

X-axis measuring system:

Interferential laser measuring system, 525 or 1115 mm long

Z-axis measuring system:

Renishaw incremental, precision length measuring system, 80 mm long

- High end length measuring instrument with large direct measuring range
- Compliant with Ernst Abbe's comparator principle
- Manual operation of measuring spindle
- Air bearings for smooth manual positioning of measuring element (with laser reflector) and counter element
- Object table height adjustment via pushbuttons (also positioning of predefined increment)
- Laser correction with respect to environmental influences: temperature, air pressure (humidity optional)
- Separate laser generator outside the measuring instrument, fed via optical cable, and laser beam cover
- Computer-aided instrument zero point stabilizing and correction of systematic instrument errors (CAA)
- Computer provided temperature measurement and computer-aided correction of temperature and measuring force influences
- Constant measuring force over the entire measuring spindle setting range
- Large object table with precision guidance in the Z direction and a loading capacity of 25 kg
- Automatic reversing point detection with static and dynamic adoption of measuring values
- Highly flexible within the application range (can be used for measuring both miniature and large measuring objects)
- Mahr 828 WIN measuring and evaluation software and MS Windows®
- Inner thread measurement supported by automatic Z positioning
- **Energy supply:** 230 V/115 V; 50/60 Hz



TECHNICAL DATA

| Order no. | | 5350263 | 5350264 |
|--|---------------|-----------------------|--------------|
| Type | | ULM 800 L-E | ULM 1500 L-E |
| Direct measuring range | mm | 0 to 525 | 0 to 1115 |
| Measuring range for outer measurement | mm | 0 to 830 | 0 to 1620 |
| Measuring range for inner measurement | mm | 0.5 to 670 | 0.5 to 1465 |
| Measuring uncertainty MPE_{E1} (L in mm) | μm | $\leq (0,1+L/2000)$ | |
| Repeatability | μm | $\leq 0,05$ | |
| Measuring forces | N | 0.2 ; 1.0 to 4.5 ; 11 | |
| Mass | kg | 220 | 325 |

| Order no. | Width | Height | Length |
|-----------|-------|--------|--------|
| | mm | mm | mm |
| 5350263 | 380 | 480 | 1500 |
| 5350264 | 380 | 480 | 2300 |

ACCESSORIES

- Large number of accessory kits and modular components for completing a wide variety of measuring tasks, including the measurement of:
 - Thread gages
 - Taper gages
 - Conical thread gages
 - Gears
- Factory calibration or DAkkS/DKD calibration can be additionally offered for this measuring station

Applications:

Calibration of

- Plain plug gages and gage rings
- Setting gage rings
- Snap gages
- Spherical gage blocks, internal micrometers
- Gage blocks
- Thread gages
- Taper thread gages
- Gear gages
- Taper gages
- Dial indicators
- Dial comparators
- 2-point bore gages
- Outside micrometers
- 2-point inside micrometers



For more information, please visit our website: www.mahr.com

FEATURES

- Useful accessory packages for the most important calibration tasks
- Software modules optimally matched to the measurement tasks

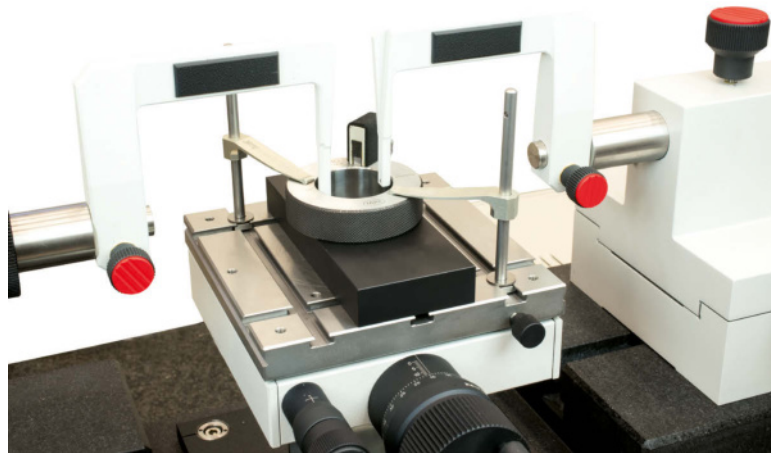

TECHNICAL DATA

| Order no. | Description | Required Number of pieces | Application | Accessories package no. |
|-----------|--|---------------------------|--|-------------------------|
| 5350161 | Software module 828 WIN "Plain gages" / "Snap gages" | 1 | | |
| 5355413 | 2 pcs. measuring attachments with knife edge 8 mm | 2 | Plain plug and ring gages ≥ 1 mm | 1 |
| 5355107 | Universal V-clamping device | 1 | | |
| 5355776 | Screw clamp for universal V-clamping device | 1 | | 2 |
| 5355127 | Measuring arms 28/4, depth 60 mm | 2 | | |
| 5355681 | Tilt table | 1 | | |
| 5350163 | Software module 828 WIN "Thread gages" | 1 | Cylindrical thread plug gages (pitch diameter) | 3 |
| 4820000 | Set A - set of thread pin gages 426 MS | 1 | | |
| 5355416 | 2 pcs. measuring attachments flat surface 7,5mm | 2 | | 4 |
| 5355101 | Single-axis floating table | 1 | | |
| 5355102 | Floating table mount | 1 | | |
| 5355779 | Set G ULM Tesa probe | 1 | Cylindrical thread ring gages $\geq M3$ (pitch diameter) | |
| 4631147 | T-probe 828 gke, $\varnothing 0.29$ mm | 1 | | |
| 5355724 | Single ball stylus $\varnothing 0.62$ mm | 1 | | |
| 7039407 | Adapter for single ball probes | 1 | | |
| 5355114 | 2 pcs parallel bars H=40mm/W=20mm | 2 | | |
| 5350166 | Software module 828 WIN "indicators/comparators/test indicators" | 1 | Indicators Comparators Test indicators | |
| 5355140 | Set E1 - Holder for indicator 8 mm | 1 | | |
| 7039499 | U-piece for test indicators | 1 | | |
| 5355414 | Measuring attachment flat 8 mm | 1 | | |

Length measuring machines for high-end calibration

The universal length measuring machines from Mahr are suitable for the absolute and relative measurement of precision products and test equipment. Typical applications here are products and test equipment used in the aerospace and automotive industries, precision engineering as well as series testing of test equipment in calibration laboratories. The PLM and CIM series thereby represents high-end length measuring machines that indicate the slightest length deviations and implement both semi-automated and automated test sequences. In other words: Metrology of the high-precision with extremely efficient processes, both in the measuring room and the calibration laboratory. The diverse range of accessory sets and components allows for the solution of the most diverse measurement and calibration tasks.



Precimar | PLM-E and CIM CNC series

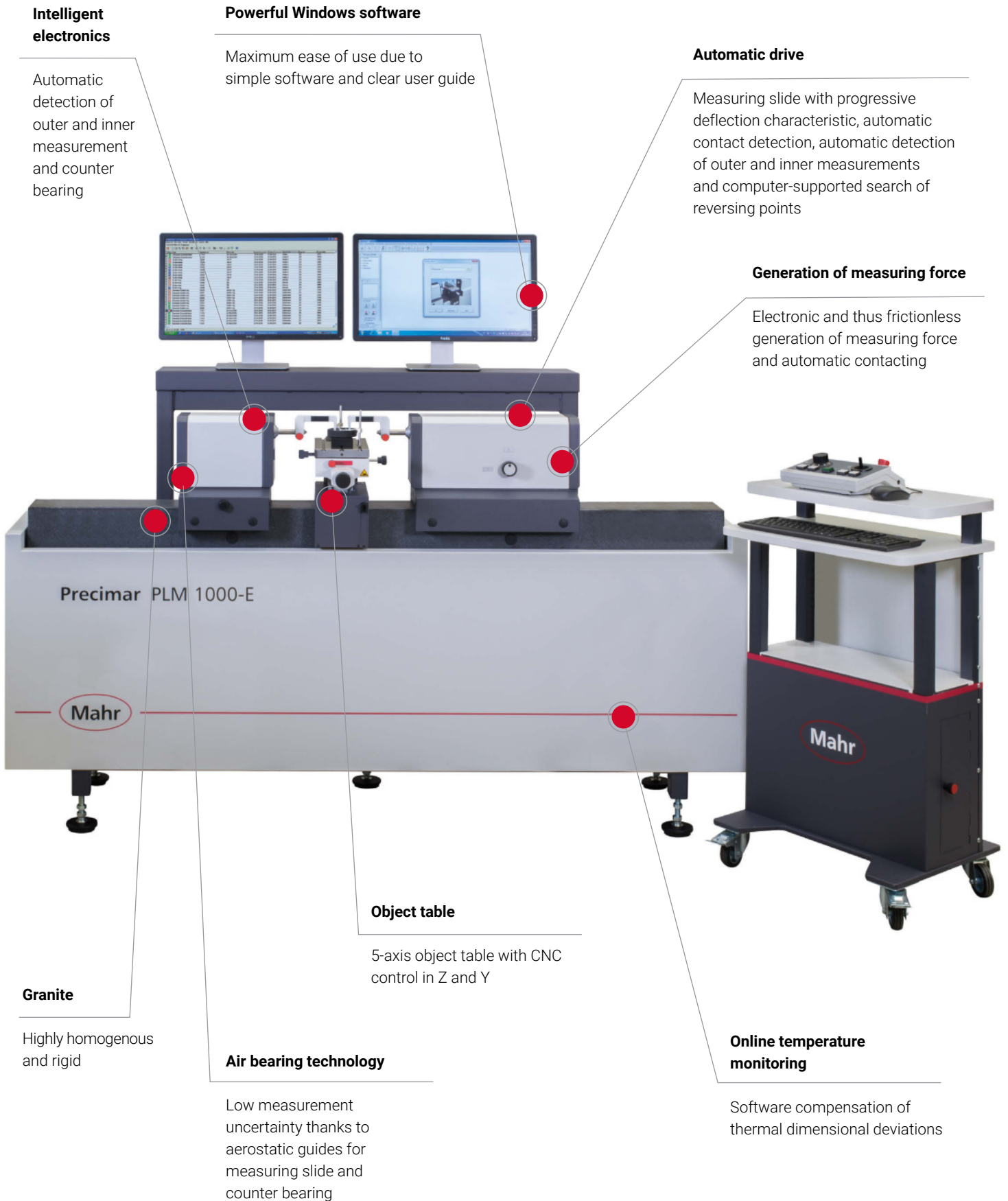

Intelligent electronics

Automatic detection of outer and inner measurement and counter bearing

Powerful Windows software

Maximum ease of use due to simple software and clear user guide

Automatic drive

Measuring slide with progressive deflection characteristic, automatic contact detection, automatic detection of outer and inner measurements and computer-supported search of reversing points

Generation of measuring force

Electronic and thus frictionless generation of measuring force and automatic contacting

Precimar PLM 1000-E

Mahr

Mahr

Object table

5-axis object table with CNC control in Z and Y

Granite

Highly homogenous and rigid

Air bearing technology

Low measurement uncertainty thanks to aerostatic guides for measuring slide and counter bearing

Online temperature monitoring

Software compensation of thermal dimensional deviations

Precimar PLM 600-E / PLM 1000-E

Precision length measuring machine

FEATURES

The PLM-E precision length measuring machine is an Abbe compliant comparator mounted on highly homogeneous rigid granite in a horizontal configuration

- Sensitive adjustment in 5 axes, and object table with a loading capacity of 35 kg
- PC-based, multi-axis machine control, including PC workstation and 828 WIN "Free measurement" basic software
- Simple operating procedure by means of measuring force-adjusted and joystick-controlled measuring slides with progressive deflection characteristic and automatic contact detection
- Automatic detection of outside and inside measurements and computer-aided search for reversal points
- The motorized measuring slide allows for high travel speeds
- The CNC-controlled vertical and cross adjustment of the universal measuring table facilitates highly efficient measuring
- State-of-the-art machine control (MarEcon)
- Recording, processing, logging and transfer of measurement data via powerful software and menu-driven controls
- Software compensation of thermal dimensional deviations
- Very easy to set the measuring force using the software
- Aerostatic guides for all slides mounted on the machine bed ensure low measurement uncertainties
- Electronic generation of measuring force and automatic contacting
- Subjective influences largely eliminated and unintended collisions with the test piece avoided.
- Automatic bore and inner thread measurement
- **Automatic TY adjustment:** What's unique is that a manual TY-adjustment is still possible
- Motorized tilting axis (TB) for alignment. Alignment is carried out via the manual control panel or using the 828 WIN software.
- A factory calibration or DAkkS/ DKD calibration is available for the Precimar PLM-E
- **Energy supply:** 230 V/115 V; 50/60 Hz



TECHNICAL DATA

| Order no. | 5350700 | | 5350800 | |
|---|-----------|--------------------|------------|--|
| Type | PLM 600-E | | PLM 1000-E | |
| Direct measuring range] | mm | 200 | | |
| Measuring range for outer measurement | mm | 0 to 600 | 0 to 1000 | |
| Measuring range for inner measurement | mm | 0.5 to 445 | 0.5 to 845 | |
| Measuring uncertainty MPE _{E1} (L in mm) | µm | ≤ (0,085 + L/1500) | | |
| Position deviation / error limit (L in mm) | µm | ≤ (0.07 + L/2000) | | |
| Repeatability | µm | ≤ 0.05 | | |
| Measuring forces | N | 0 to 13.9 | 0 to 13.9 | |
| Mass | kg | 480 | 535 | |

| Order no. | Width | Height | Length |
|-----------|-------|--------|--------|
| | mm | mm | mm |
| 5350700 | 790 | 1300 | 1660 |
| 5350800 | 790 | 1300 | 2110 |

ACCESSORIES

- Large number of accessory kits and modular components for completing a wide variety of measuring tasks, including the measurement of:
 - Thread gages
 - Conical thread gages
 - Gears
 - Thread pitches

Applications:

Calibration of

- Plain plug gages and gage rings
- Setting gage rings
- Snap gages
- Spherical gage blocks, internal micrometers
- Gage blocks
- Thread gages
- Taper thread gages
- Gear gages
- Dial indicators
- Dial comparators
- 2-point bore gages
- Outside micrometers
- 2-point inside micrometers
- Precision length measurement
- Measurement of thin-walled and deformed workpieces

Precimar CIM 1000 CNC

Precision length measuring machine

FEATURES

The Precimar CIM 1000 CNC precision length measuring machine is an Abbe-compliant comparator with horizontal base bed (highly homogeneous, rigid granite)

- Electronically controlled measuring force generation
- Motorized measuring spindle control with joystick and automatic contacting
- Air bearings for smooth positioning of measuring slide, counter bearing and object table
- Sensitive adjustment in 5 axes, and object table with a loading capacity of 25 kg
- Motorized object table height adjustment via joystick or CNC
- Maximum measuring accuracy
- Fast and reliable measurement
- Exceptionally low length measuring uncertainty for precision parts and gage monitoring
- Compliant with Ernst Abbe's comparator principle
- Online temperature monitoring
- Software-supported measuring force generation, especially advantageous for thin-walled workpieces and gages
- Semi-automatic bore and inner thread measurement
- Measuring and evaluation software runs under MS Windows®, 828 WIN
- Patented measuring procedure
- Aerostatic guides for all slides mounted on the machine bed ensure extremely low measuring uncertainties
- Movable measuring spindle mount via a spring parallelogram free from play and friction
- Electronic measuring force adjustment and automatic contacting – largely eliminating subjective influences and avoiding unintended collisions with the testpiece
- Possibility of calculating measuring result down to measuring force 0 N (dynamic measuring)
- **Energy supply:** 230 V/115 V; 50/60 Hz

ACCESSORIES

- Large number of accessory kits and modular components for completing a wide variety of measuring tasks, including the measurement of:
 - Thread gages
 - Conical thread gages
 - Gears
 - Thread pitches
- Factory calibration or DAkkS/DKD calibration can be additionally offered for this measuring station



TECHNICAL DATA

| Order no. | | 5350701 | |
|---|----|--------------------|--|
| Type | | CIM 1000 CNC | |
| Direct measuring range | mm | 300 | |
| Measuring range for outer measurement | mm | 0 to 1000 | |
| Measuring range for inner measurement | mm | 0.5 to 845 | |
| Measuring uncertainty MPE _{E1} (L in mm) | µm | ≤ (0.055 + L/1500) | |
| Position deviation / error limit (L in mm) | µm | ≤ (0.04 + L/2000) | |
| Repeatability | µm | ≤ 0,03 | |
| Measuring forces | N | 0 to 13.9 | |
| Mass | kg | 840 | |

| Order no. | Width | Height | Length |
|-----------|-------|--------|--------|
| | mm | mm | mm |
| 5350701 | 700 | 1700 | 2500 |

Applications:

Calibration of

- Plain plug gages and gage rings
- Setting gage rings
- Snap gages
- Spherical gage blocks, internal micrometers
- Gage blocks
- Thread gages
- Taper thread gages
- Gear gages
- Dial indicators
- Dial comparators
- 2-point bore gages
- Outside micrometers
- 2-point inside micrometers
- Precision length measurement
- Measurement of thin-walled and deformed workpieces

MarSurf | Surface measuring instruments

Careful testing is paramount wherever surface structures affect the function or appearance of components. MarSurf surface measuring instruments offer outstanding quality. Mahr has perfected the stylus method, which has now become established worldwide. But we can also meet the latest demands for contactless measuring with a range of optical sensors. Mahr's MarSurf surface metrology offers a combination of top quality, maximum competence and perfect expertise.



| | |
|--|------------|
| Overview MarSurf | 518 |
| Surface measuring instruments | |
| MarSurf Pocket Surf IV | 520 |
| Mobile roughness measuring instrument | |
| MarSurf PS 10 | 524 |
| Mobile roughness measuring instrument | |
| MarSurf M 310 | 428 |
| Mobile roughness measuring instrument | |
| MarSurf M 310 PC | 530 |
| Mobile roughness measuring instrument | |
| MarSurf M 400 | 534 |
| Mobile surface measuring instrument | |
| MarSurf XR 1 | 538 |
| Roughness measuring station | |
| MarSurf GD 140 / GD 280 | 539 |
| Roughness measuring station | |
| MarSurf CD 140 A | 542 |
| Contour measuring station | |
| MarSurf CD 140 / CD 280 | 543 |
| Contour measuring station | |
| MarSurf VD 140 / VD 280 | 544 |
| Roughness and contour measuring station | |
| MarSurf UD 130 / LD 130 / LD 260 | 548 |
| Combined contour and surface measuring station | |
| MarSurf CNC modular | 549 |

Optical or tactile?

Selecting the right measuring equipment

When should you rely on tactile metrology and when does it make more sense to measure using established optical devices? As both methods are equally precise, delivering results with 99 % accuracy, it always comes down to the surface structures you want to measure and which parameters are relevant for your production. Mahr offers you versatile solutions for both types of systems. The following criteria will help you make your selection:

1

Process values in accordance with ISO 4287, ISO 13565, ISO 25178 und ISO 21920

Tactile and optical devices identify the roughness and sometimes the waviness of surfaces – all the while in compliance with the standards DIN EN ISO 4287 and DIN EN ISO 13565. Optical devices also comply with the standard DIN EN ISO 25178 and in future with the standard DIN EN ISO 21920, which allow for an extensive description of a surface without contact.

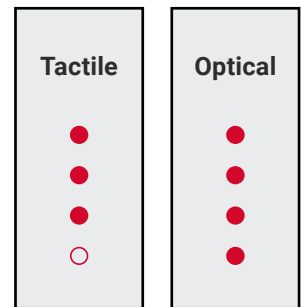

2

Get established process values in the blink of an eye

Roughness, waviness and primary profiles describe the surface and its properties. The parameters derived from that provide information about the quality of the surface. This guarantees reliability in the production process and makes it possible to carry out incoming goods checks quickly.

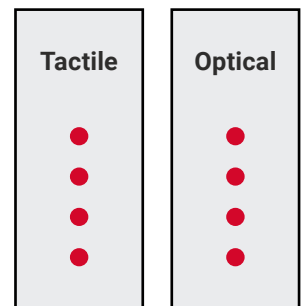

3

Statistical testing

When it comes to machined surfaces, structures are often no longer arranged in a certain direction but are distributed at random. A 2D section does not sufficiently describe them or, if it does, it is extremely time consuming. However, the extensive optical sampling of the surface provides more information and fast measuring results.

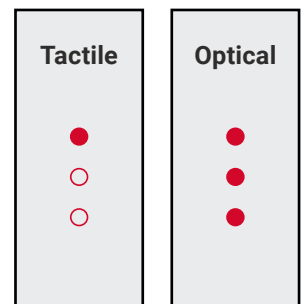



4

Measurement at the touch of a button

Simply place the probe arm on the surface, press the button and begin measurement – no need for complicated peripherals. Read the results directly on the display and print them out with the associated printer as desired. Enjoy all of this at an unbeatable price-performance ratio.

| Tactile | Optical |
|---------|---------|
| ● | ○ |
| ● | ○ |
| ● | ○ |
| ● | ○ |

5

Topological testing

When surfaces are extremely sensitive, soft, sticky or even discontinuous, non-contact and thus optical measurement is the method of choice. This applies equally to coated, inhomogeneous and complex surfaces as well as to surfaces without processing structures: It is best to scan and evaluate them optically.

| Tactile | Optical |
|---------|---------|
| ● | ● |
| ○ | ● |
| ○ | ● |
| ○ | ● |

6

Easy accessibility

Both optical and tactile mobile devices enable reliable surface testing directly on the workpiece in the production area. To examine surfaces, small depressions or drill holes that are difficult to access, the removable drive units in tactile tools also present a particular advantage.

| Tactile | Optical |
|---------|---------|
| ● | ● |
| ● | ● |
| ● | ○ |

MarSurf Pocket Surf IV

Mobile roughness measuring instrument



FEATURES

- Sturdy housing made of cast aluminum guarantees accurate and reliable measurement operation over many years
- Measurement of four selectable parameters: Ra, Rmax/Ry, Rz
- Reading of all the parameters after the measurement is completed
- Measuring length adjustable based on 1x, 3x or 5x the cutoff wavelength 0.8 mm/0.030"
- Can be implemented in any position – horizontal, vertical and upside down
- Four locking probe positions – axial or at 90°, 180°, or 270° angle
- Even difficult to reach surfaces on the inner and outer diameters are accessible
- MarConnect data output for simple data transmission, compatible with standard data recording systems
- Easy to read LCD displays the measured roughness parameters in μm or μinch immediately after scanning the surface
- Messages indicating when ranges exceed or fall below a limit and a battery warning symbol are also displayed
- Simplified calibration process
- Improved battery life with easy to replace 9V battery



Applications:

- Pocket-sized, economically priced, completely portable instrument
- Performs traceable surface roughness measurements on a wide variety of surfaces
- Can be used confidently in production, on the shop floor and in the laboratory

TECHNICAL DATA

| Order no. | 2191800 | 2191802 |
|--|---------------------------------------|--|
| Type | Pocket Surf IV | |
| Parameters | Ra, Ry, Rmax, Rz | |
| Stylus | 10 μm / .0004" | 5 μm / .0002" |
| Data interface | RS-232C, USB | |
| Rechargeable batteries | Battery, 9V | |
| H x W x D | mm | 140 x 76 x 6.35 mm |
| Measuring principle | Skid probe system | |
| Probe | Piezoelectric skid probe | |
| Measuring range | mm | Ra –6.35 μm / 250 Ry, Rmax, Rz –25.3 μm / 999 μin |
| Profile resolution | 0.01 μm / 1 μin | |
| Number n of sampling length according to ISO/JIS | Selected: 1 –5 | |
| Measuring force | N | 15 mN |
| Positioning speed | 1.0 | |

MarSurf Pocket Surf IV

Mobile roughness measuring instrument

ACCESSORIES

| Order no. | Description | Type |
|-----------|---|-------------|
| 2008010 | General purpose probe, 10µm/90° | EGH-1019 |
| 2008012 | Transverse chisel probe 10 µm | EGH-1020-W1 |
| 2008013 | Parallel chisel probe | EGH-1020-W2 |
| 2008014 | Small bore probe, 10µm/90° | EGH-1021 |
| 2008011 | General purpose probe, 5µm/90° | EGH-1026 |
| 2008015 | Small bore probe, 5µm/90° | EGH-1027 |
| 2008016 | Groove bottom probe, 5µm/90° | EGH-1028 |
| 2008024 | Compact height stand | EAS-2496 |
| 2008025 | Universal stand | EAS-2426 |
| 2008026 | Column clamp for EAS-2426 | EAS-2567 |
| 2008027 | Adapter plate | EPL-1681 |
| 2008023 | Portable V-fixture | EAS-2421 |
| 2008022 | Bottom plate | EAS-2584 |
| 2008021 | Bore adapter kit | EAS-2839 |
| 2008020 | V-adapter kit | EAS-2739 |
| 2008030 | Certified specimen, incl. test certificate | PMD-90101 |
| 2008031 | Precision reference specimen, without certificate | EMD-90010 |
| 4346020 | Data connection cable RS232C (2 m) | 2000 r |
| 4346023 | 2000 USB data connection cable USB (2 m) | 2000 USB |

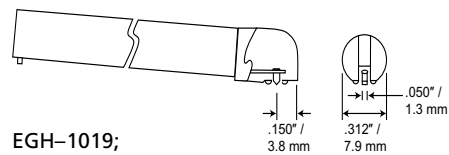

EGH-1019;
EGH-1026



EAS-2421



EAS-2584



EAS-2739



EAS-2839

PS 10 – Mobile measuring made easy

The MarSurf PS 10 is the ideal entry level instrument for surface metrology: Its extraordinarily simple and intuitive operation, along with numerous safety functions including the automatic cutoff, make the device as easy to control as a cellphone. Due to its minimal size, it is also perfect for location-independent measurements – vertical, horizontal and even overhead if necessary. And thanks to the removable drive unit, the MarSurf PS 10 can be used flexibly in production.

The measuring instrument boasts three order options for increased flexibility: with stylus tip 2 µm, 5 µm and also a variant with a transverse drive unit (MarSurf PS 10 C2).

- Intuitive operation: As easy as using a smartphone with a rotatable display
- Creates complete PDF measuring records right in the measuring instrument and data backup as TXT, X3P, CSV and PDF files
- Customized comments for the PDF measuring record entered directly into the MarSurf PS 10
- Error-free operation thanks to an integrated, removable roughness standard
- Automatic cutoff selection, ensuring that even non-specialists get the correct measuring results

9

other optional
probes

Always at hand

The calibration standard stays in the instrument and can be checked at any time.

500 g
lightweight



Extremely easy to operate with detailed profile display

The large 4.3" high-resolution and backlit TFT touch display allows intuitive operation and precise representation of the measuring profile.

Perfect evaluation and documentation

Measuring records are automatically created in the instrument without the need for additional software.

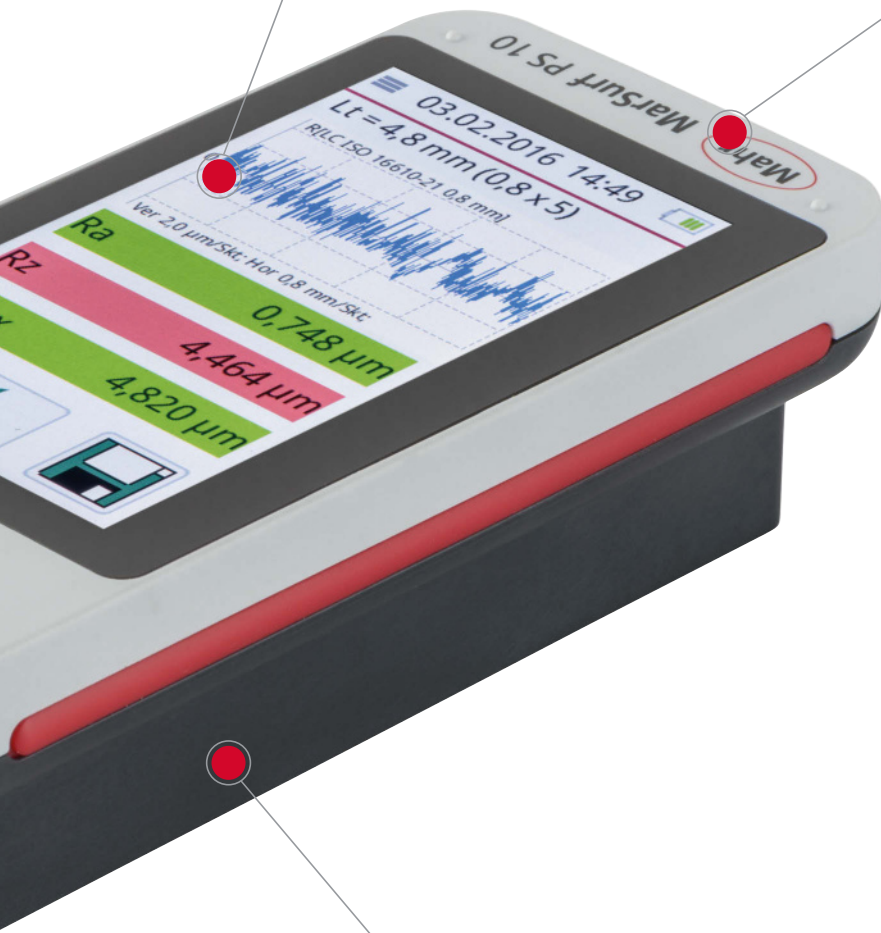

up to

500,000

measurements

can be stored in the instrument

31

parameters

same range of functions as a laboratory instrument

4.3"

TFT touch display

similar to a smartphone

Flexible use

The removable drive unit, in conjunction with the optional handheld support, lends this instrument added versatility where space is limited, e.g. in holes or when measuring small parts.

at least

1,200

measurements

without power supply



FEATURES

MarSurf PS 10 – simple, smart and mobile

- Compact roughness measuring instrument for mobile use
- Simple and intuitive to use: as easy as using a smart phone
- Large, illuminated 4.3" TFT touch display
- Adjustable display
- Data backup as TXT, X3P, CSV or PDF file
- Create complete PDF measuring records directly in the measuring instrument
- Customized comments for the PDF measuring record can be entered directly into the MarSurf PS 10
- Mains-independent operation: Over 1200 measurements without having to recharge the instrument
- An all-in-one solution. Small and lightweight (approx. 500 g)
- Instrument flexibility: removable drive unit
- 31 surface parameters: offer the same range of functions as a laboratory instrument
- Roughness standard stored within housing aids in reducing errors
- Quick access to your frequently used functions via the Favorites list in the display
- Automatic cutoff selection, so even non-specialists can be sure of getting the correct measuring results
- Additional version with transverse drive unit available as MarSurf PS 10 C2 (item number 6910235)

Package contents:

- MarSurf PS 10 unit
- Drive unit (detachable)
- 1 standard probe conforming to standards
- Built-in rechargeable battery
- Roughness standard integrated into housing (detachable), including Mahr calibration certificate
- Probe protection
- Power source with 3 adapters
- Operating instructions
- Carry case with shoulder strap
- USB cable
- Extension cable for drive unit (length 1.2 m)
- Height adjustment (integrated)
- **Software:** MarCom Professional free download: www.mahr.com/marcom (only for Mahr data cables and wireless systems with USB and RS-232 interface)



Applications:

- For shafts and housing components
- For large machines
- For large workpieces
- For milled and turned parts
- For ground and honed workpieces
- On the production line or directly on the machine; ideal for rapid testing of the surface roughness of a workpiece

TECHNICAL DATA

| Order no. | 6910230 | 6910232 |
|--|---|------------------------|
| Type | PS 10 | |
| Parameters | Ra, Rq, Rz (Ry (JIS) is equivalent to Rz), Rz (JIS), Rmax, Rp, RpA (ASME), Rpm (ASME), Rpk, Rk, Rvk, Mr1, Mr2, A1, A2, Vo, Rt, RPl, Rmr (tp (JIS, ASME) is equivalent to Rmr), RSm, RSk, RS, CR, CF, CL, R, Ar, Rx, R3z | |
| Stylus | 2 µm | 5 µm |
| Calibration function | Dynamic; Ra, Rz, Rsm | |
| Storage capacity | Min. 3900 profiles, min. 500,000 results, min. 1500 PDF records, expandable to 32 GB with Micro SD card | |
| Languages | German, English, French, Italian, Spanish, Portugese, Dutch, Swedish, Russian, Polish, Czech, Japanese, Chinese, Korean, Hungarian, Turkish, Romanian | |
| Other | Lock/password protected, date/time | |
| Data interface | USB, MarConnect (RS-232), Micro SD slot for SD / SDHC cards up to 32 GB | |
| System of protection | IP 40 | |
| Rechargeable batteries | Lithium-ion battery, min. 1200 measurements | |
| Wide range power supply | 100 to 264 V | |
| H x W x D | mm | 160 mm x 77 mm x 50 mm |
| Measuring principle | Stylus method | |
| Probe | Inductive skidded probe | |
| Measuring range | mm | 0.350 |
| Profile resolution | 8 nm | |
| Filter according to ISO/JIS | Gaussian filter as per ISO 16610-21 (formerly ISO 11562), special filter as per DIN EN ISO 13565-1, Lambda s filter as per DIN EN ISO 3274 (can be switched off) | |
| Cutoff lc according to ISO/JIS | 0.25 mm, 0.8 mm, 2.5 mm, automatic filter detection | |
| Number n of sampling length according to ISO/JIS | Selectable: 1 to 16 | |
| Short stroke under ISO/JIS | Selectable | |
| Traversing length Lt according ISO/JIS | 1.5 mm, 4.8 mm, 15 mm, N x Lc, variable, automatic | |
| Traversing length according ISO 12085 (MOTIF) | 1 mm, 2 mm, 4 mm, 8 mm, 12 mm, 16 mm | |
| Evaluation length ln according to ISO/JIS | 1.25 mm, 4.0 mm, 12.5 mm | |
| Measuring force | N | 0,00075 |
| Positioning speed | 0.5; 1.0 | |

ACCESSORIES

| Order no. | Description | Type |
|-----------|---|-----------------------------|
| 6850540 | PHT pick-up extension 80 mm | PHT (80 mm) |
| 6111520 | Standard probe 2 μm | PHT 6–350 |
| 6111526 | Standard probe 5 μm | PHT 6–350/ 5 μm |
| 6111527 | Standard probe 10 μm | PHT 6–350/ 10 μm |
| 6111521 | Probe for bores with a diameter larger than 3 mm | PHT 3–350 |
| 6111524 | Probe for grooves | PHT 11–100 |
| 6111525 | Probe for concave and convex surfaces | PHTR–100 |
| 6111522 | Probe for gear tooth flanks | PHTF 0.5–100 |
| 6111523 | Probe for metal sheets | PT 150 |
| 6850715 | Pick-up protection with header V-block, steel | PHT-ts4 |
| 7028530 | Pick-up protection header V-block, plastic | PHT-ts3 |
| 6910209 | Mount PS 10/M310 on measuring stand ST | ST-a3 |
| 6910435 | RD 18 C / PS 10 upright holder for cylindrical drive unit, \varnothing 8 mm | ST-a2 |
| 6710803 | Measuring stand 300 mm with cast iron base | ST-D |
| 6710806 | Measuring stand 300 mm with granite plate | ST-F |
| 6710807 | Measuring stand 300 mm with granite plate and T-slot | ST-G |
| 2247086 | Adjustable mounting bracket to connect to 814 SR | 814 Sh |
| 4426100 | Height measuring and scribing instrument, 0 –350 mm | 814 SR |
| 4426101 | Height measuring and scribing instrument, 0 –600 mm | 814 SR |
| 4102357 | 16 EXu data connection cable USB (2 m) (hardware Revision 1) | 16 EXu |
| 4102603 | Data cable USB bi-directional (2 m) (hardware Revision 2) | DK-U1 |
| 6710401 | V-block | PP |
| 6710604 | Parallel vice | PPS |
| 6710529 | XY Table | CT 120 |
| 4246819 | Set of miniature precision vises, set contents: mini-vises, jaw widths 15 / 25 / 35 mm, with tripod and V-blocks and miniature dividing attachments | 109 PS |
| 6820420 | Roughness standard with Mahr calibration certificate, profile depth 10 μm | PRN 10 |
| 4413000 | Measuring tripod with triangular pedestal 300 mm | 815 GN |
| 4413001 | Measuring tripod with triangular pedestal 500 mm | 815 GN |
| 4413005 | Measuring tripod with triangular pedestal 750 mm | 815 GN |
| 4416000 | Measuring tripod with magnetic base | 815 MA |
| 6299054 | Evaluation software | SW XR 20 |
| 6910240 | Protective films for LCD, real glass (3 pieces) | SF LCD |
| 680000DKS | Geometric standard, sinusoidal profile | MGs 1 |
| 680000KAL | Geometric standard, sinusoidal profile | MGs 1 |
| 680001DKS | Geometric standard, sinusoidal profile | MGs 3 |
| 680001KAL | Geometric standard, sinusoidal profile | MGs 3 |
| 680002DKS | Geometric standard, sinusoidal profile | MGs 10 |
| 680002KAL | Geometric standard, sinusoidal profile | MGs 10 |

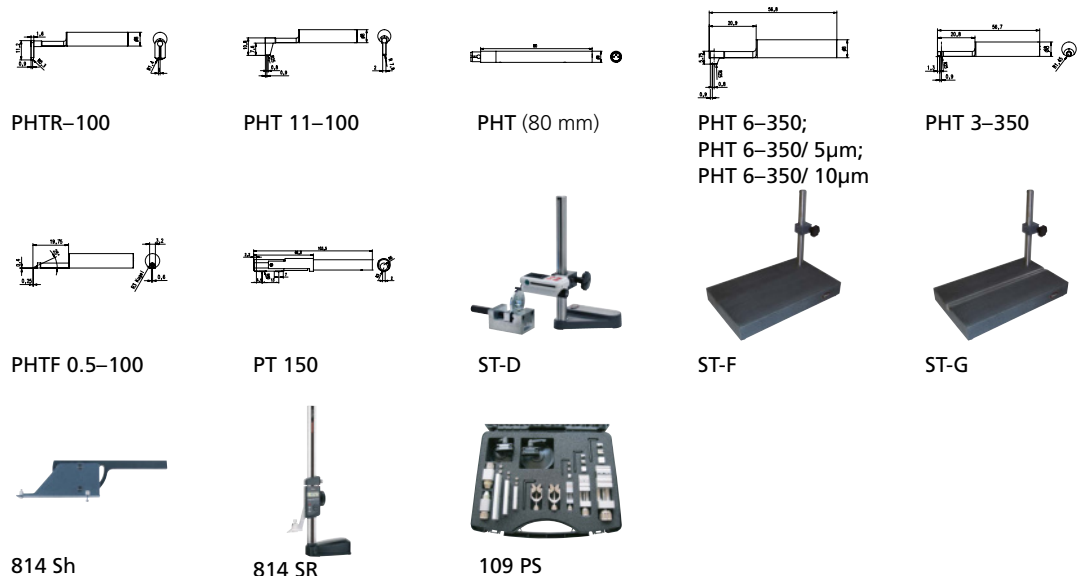

M 310 – Brings added value for mobile roughness measurement

Are you used to using your smartphone to access your data anytime, wherever you are? That is exactly what Mahr's MarSurf M 310 provides you with: A versatile device for the mobile recording and evaluation of measuring data. Simple operation and a robust design

make this Mahr product perfectly suited for use in production, where dirt and dust can clog the instrument and it is often users with little prior knowledge performing the quality control.

For all those who need more

The **MarSurf M 310** has the same functions as the PS 10 but has even more crucial added benefits for you:

- 1 Print directly, document easily**
Measuring results in paper form? Sometimes still the fastest way! The mobile printer allows you to save data on thermal paper, which can then be added directly to the workpiece.
- 2 Preprogrammed measuring functions for immediate measuring success**
A variety of measuring parameters can be defined, saved and then called up on the workpiece in the device settings. Additionally, it works using a barcode scanner, which simply connects to the MarSurf M 310. This allows even workers without expert knowledge or training to determine reliable roughness parameters.
- 3 Robot ready: Integrate instrument directly in the production line**
The MarSurf M 310 and its interfaces can be directly integrated into your production lines, such as for measuring tasks on the robot arm. They control the measuring instrument remotely – conveniently from your computer, for example.

Status at a glance

Instrument status at a glance thanks to two easily visible status LEDs. Depending on the signal color, a measurement is underway, data is being transferred or an error has been detected. Standby mode shows the charging status.

Robust in every respect

Equipped for virtually any environment: The robust skidded probe system means that the measuring instrument is less sensitive to vibrations. The PHT probe is easy to clean due to its open skid.

Modern optics, perfect display

A high resolution, backlit 4.3" TFT display ensures precise display of your measuring results. It is operated directly via the touchscreen – just as you are used to with your smartphone.

IATF compliant

The MarConnect duplex interface enables the transmission of a measuring equipment ID with each measurement. This makes measuring results traceable at any time.

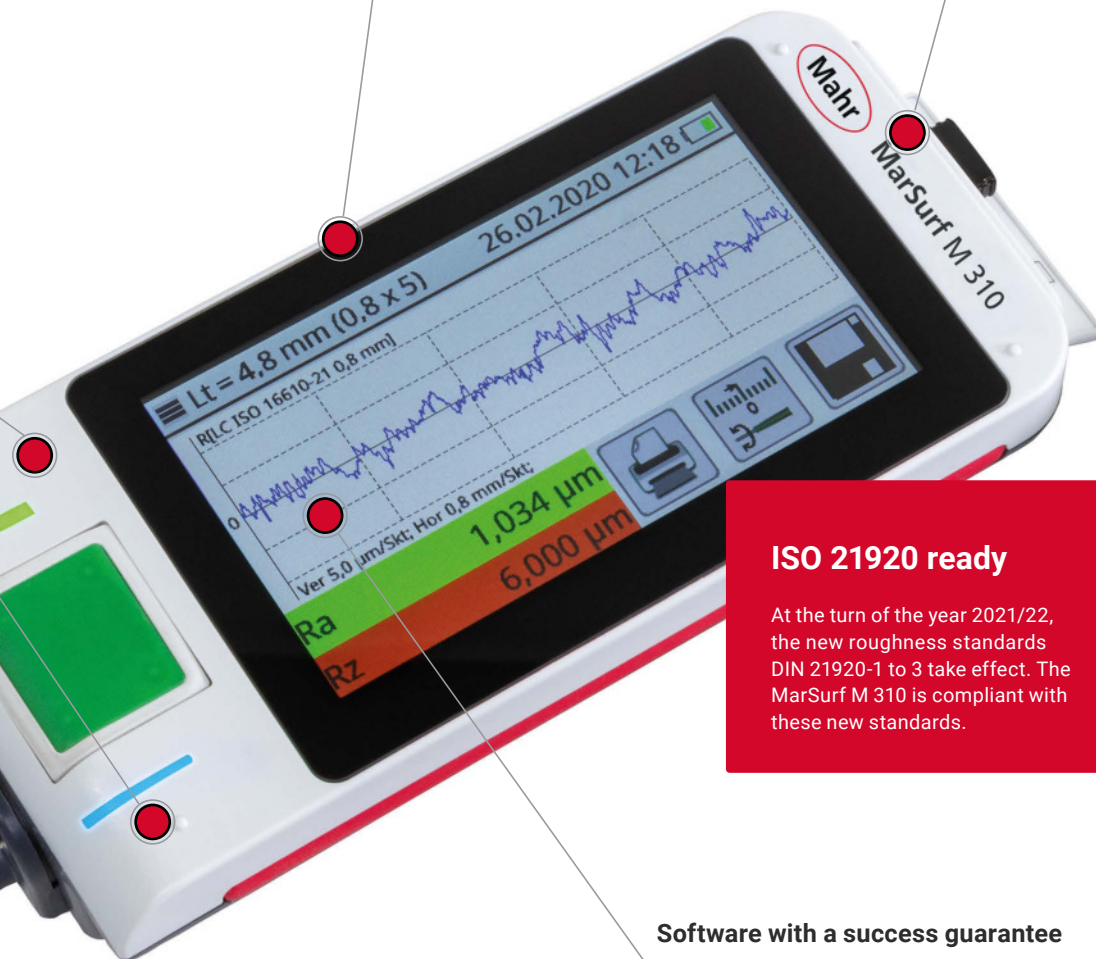

ISO 21920 ready

At the turn of the year 2021/22, the new roughness standards DIN 21920-1 to 3 take effect. The MarSurf M 310 is compliant with these new standards.

Software with a success guarantee

With this measuring instrument, you can reliably determine roughness parameters even without expert knowledge or training – due to intuitive software, clear menu structures and preprogrammed measuring functions.



MarSurf M 310 / M 310 C2 for transverse measurement / M 310 with printer

Mobile roughness measuring instrument

FEATURES

Mobile roughness measurement – guaranteed success!

- Compact roughness measuring instrument for mobile use
- Simple and intuitive to use: as easy as using a smartphone
- Large, illuminated 4.3" TFT touch display
- Adjustable display
- Micro USB interface for remote control using ASCII commands, e.g. using software for statistical process control
- USB-A interface - for connection of e.g. a USB Bluetooth adapter or the USB/Bluetooth printer
- Wireless transmission of measurement results via Bluetooth stick to the free MarCom software
- Remote start of measurement via cable or Bluetooth
- Connection of a scanner for automatic start of the measuring programs or reading of protocol texts via barcode or QR code
- Specification of the intersection line C in μm or in % of Rz for the parameters Rmr and tp
- Data backup as TXT, X3P, CSV or PDF file
- Transfer of measuring records and data optionally via Bluetooth or cable
- IATF 16949 compliant – safe traceability with MarConnect
- Print directly on mobile printer (as option or directly in set with printer)
- Create complete PDF measuring records directly in the measuring instrument
- Customer-specific comments for the PDF measuring record can be entered directly into MarSurf M 310
- Display and printout of the MRC and ADC diagram
- Storage of measuring programs (quick and easy)
- **Mains-independent operation:** Over 1200 measurements without having to recharge the instrument
- An all-in-one solution. Small and lightweight (approx. 500 g)
- Instrument flexibility: removable drive unit
- **31 thread parameters:** offer the same range of functions as a laboratory instrument.
- Roughness standard stored within housing aids in reducing errors
- Quick access to your frequently used functions via the Favorites list in the display
- Automatic cutoff selection, so even non-specialists can be sure of getting the correct measuring results
- Additional versions with transverse drive unit available as MarSurf M 310 C2 or MarSurf M 310 set without probe
- Free software "MarWin Easy



Applications:

- For shafts and housing components
- For large machines
- For large workpieces
- For milled and turned parts
- For ground and honed workpieces
- On the production line or directly on the machine, ideal for rapid testing of the surface roughness of a workpiece in or on the machine

TECHNICAL DATA

| Order no. | 6910260 | 6910264 | 6910265 | 6910267 | 6910268 |
|---|---|-------------------------------------|-----------------|--------------------|-----------------|
| Type | M 310 | M 310 C2 for Transverse measurement | M 310 | M 310 with printer | |
| Parameters | A1, A2, Ar, CF, CL, CR, Mr1, Mr2, R, R3z, R _{Pc} , R _S , R _{Sk} , R _{Sm} , Ra, Rk, R _{max} , R _{mr} (tp (JIS, ASME) is equivalent to R _{mr}), R _p , R _{pA} (ASME), R _{pk} , R _{pm} , R _{pm} (ASME), R _q , R _t , R _{vk} , R _x , R _z , R _z (JIS), R _z (Ry (JIS) is equivalent to R _z), V _o | | | | |
| Stylus | 2 μm | | 5 μm | 2 μm | 5 μm |
| Calibration function | Dynamic; Ra, Rz, R _{sm} | | | | |
| Storage capacity | Min. 3900 profiles, min. 500,000 results, min. 1500 PDF measuring records, expandable to 32 GB with microSD card (320x memory capacity) | | | | |
| Languages | German, English, French, Italian, Spanish, Portugese, Dutch, Swedish, Russian, Polish, Czech, Japanese, Chinese, Korean, Hungarian, Turkish, Romanian | | | | |
| Other | Lock/password protected, date/time | | | | |
| Data interface | USB A, USB B, MarConnect (bidirectional), Micro SD slot for SD / SDHC cards up to 32 GB | | | | |
| System of protection | IP 40 | | | | |
| Rechargeable batteries | Lithium-ion battery, 3.7 V, nominal capacity 11.6 Wh, min. 1200 measurements | | | | |
| Wide range power supply | 100 to 264 V | | | | |
| H x W x D | mm | 160 mm x 77 mm x 50 mm | | | |
| Measuring principle | Stylus method | | | | |
| Probe | Inductive skidded probe | | | | |
| Measuring range | 0.350 | | | | |
| Profile resolution | 8 nm | | | | |
| Filter according to ISO/JIS | Gaussian filter as per ISO 16610-21 (formerly ISO 11562), special filter as per DIN EN ISO 13565-1, Lambda s filter as per DIN EN ISO 3274 (can be switched off) | | | | |
| Cutoff l _c according to ISO/JIS | 0.25 mm, 0.8 mm, 2.5 mm, automatic filter detection, variable | | | | |
| Number n of sampling length according to ISO/JIS | Selectable: 1 to 16 | | | | |
| Short stroke under ISO/JIS | Selectable | | | | |
| Traversing length l _t according ISO/JIS | 1.5 mm, 4.8 mm, 15 mm, N x l _c , variable, automatic | | | | |
| Traversing length according ISO 12085 (MOTIF) | 1 mm, 2 mm, 4 mm, 8 mm, 12 mm, 16 mm | | | | |
| Evaluation length l _n according to ISO/JIS | 1.25 mm, 4.0 mm, 12.5 mm | | | | |
| Measuring force | N | .00075 | | | |
| Positioning speed | 0.5; 1.0 | | | | |

Roughness Viewer" for further documentation (statistics, multiple profiles and results on one page etc.) available for download on the Mahr website.

Package contents:

- MarSurf M 310 basic device
- Drive unit (detachable)
- 1 standard probe PHT6-350,

conforming to standards

- Built-in rechargeable battery
- Roughness standard integrated into housing (detachable), including Mahr calibration certificate
- Probe protection / V-block holder
- Charger / 3 adapters
- Height adjustment (integrated)
- Carry case with shoulder strap

• USB cable

- Hand-held support with height adjustment (pair)
- Roughness standard integrated into housing (detachable), including Mahr calibration certificate
- Extension cable for drive unit (length 1.2 m)
- Operating instructions

MarSurf M 310

Mobile roughness measuring instrument

ACCESSORIES

| Order no. | Description | Type |
|------------|---|-----------------------|
| 6910271 | Printer set for MarSurf M 310 | DP-B1 |
| 4102603 | Data cable USB bi-directional (2 m) | DK-U1 |
| 3028620 | USB 2D scanner Honeywell Xenon 1900 | Handset scanner cable |
| 3003856 | USB Bluetooth adapter | USB BT |
| 3028820 | 2D scanner Bluetooth Zebra DS2278 | Handset scanner BT |
| 6850540 | PHT pick-up extension 80 mm | PHT (80 mm) |
| 6111520 | Standard probe 2 µm | PHT 6-350 |
| 6111526 | Standard probe 5 µm | PHT 6-350/ 5µm |
| 6111527 | Standard probe 10 µm | PHT 6-350/ 10µm |
| 6111521 | Probe for bores with a dia. larger than 3 mm | PHT 3-350 |
| 6111524 | Probe for grooves | PHT 11-100 |
| 6111525 | Probe for concave and convex surfaces | PHTR-100 |
| 6111522 | Probe for gear tooth flanks | PHTF 0.5-100 |
| 6111523 | Probe for metal sheets | PT 150 |
| 6850715 | Pick-up protection with header V-block, steel | PHT-ts4 |
| 7028530 | Pick-up protection header V-block, plastic | PHT-ts3 |
| 6910209 | Mount PS 10/M310 on measuring stand ST | ST-a3 |
| 6910435 | RD 18 C / PS 10 upright holder for cylindrical drive unit, Ø 8 mm | ST-a2 |
| 6710803 | Measuring stand 300 mm with cast iron base | ST-D |
| 6710806 | Measuring stand 300 mm with granite plate | ST-F |
| 6710807 | Measuring stand 300 mm with granite plate and T-slot | ST-G |
| 2247086 | Adjustable mounting bracket to connect to 814 SR | 814 Sh |
| 4426100 | Height measuring and scribing instrument, 0 -350 mm | 814 SR |
| 4426101 | Height measuring and scribing instrument, 0 -600 mm | 814 SR |
| 6710401 | V-block | PP |
| 6710604 | Parallel vice | PPS |
| 6710529 | XY Table | CT 120 |
| 4246819 | Set of miniature precision vises, set contents: mini-vises, jaw widths 15 / 25 / 35 mm, with tripod and V-blocks and miniature dividing attachments | 109 PS |
| 6820420 | Roughness standard with Mahr calibration certificate, profile depth 10 µm | PRN 10 |
| 4413000 | Measuring tripod with triangular pedestal 300 mm | 815 GN |
| 4413001 | Measuring tripod with triangular pedestal 500 mm | 815 GN |
| 4413005 | Measuring tripod with triangular pedestal 750 mm | 815 GN |
| 4416000 | Measuring tripod with magnetic base | 815 MA |
| 6299054 | Evaluation software | SW XR 20 |
| 6910240 | Protective films for LCD, real glass (3 pieces) | SF LCD |
| 6850500 | Magnetic fixture PS 10 / M 310 | MH |
| 6820521 | PS 10 Gage / Geometric Standard incl. Mahr Calibration Certificate | PS 10 KN Mahr |
| 6299436 | Software MarWin 13 EasyRoughness mobile | M 310 PC |
| 6800000DKS | Geometric standard, sinusoidal profile | MGs 1 |
| 6800000KAL | Geometric standard, sinusoidal profile | MGs 1 |
| 6800001DKS | Geometric standard, sinusoidal profile | MGs 3 |
| 6800001KAL | Geometric standard, sinusoidal profile | MGs 3 |
| 6800002DKS | Geometric standard, sinusoidal profile | MGs 10 |
| 6800002KAL | Geometric standard, sinusoidal profile | MGs 10 |

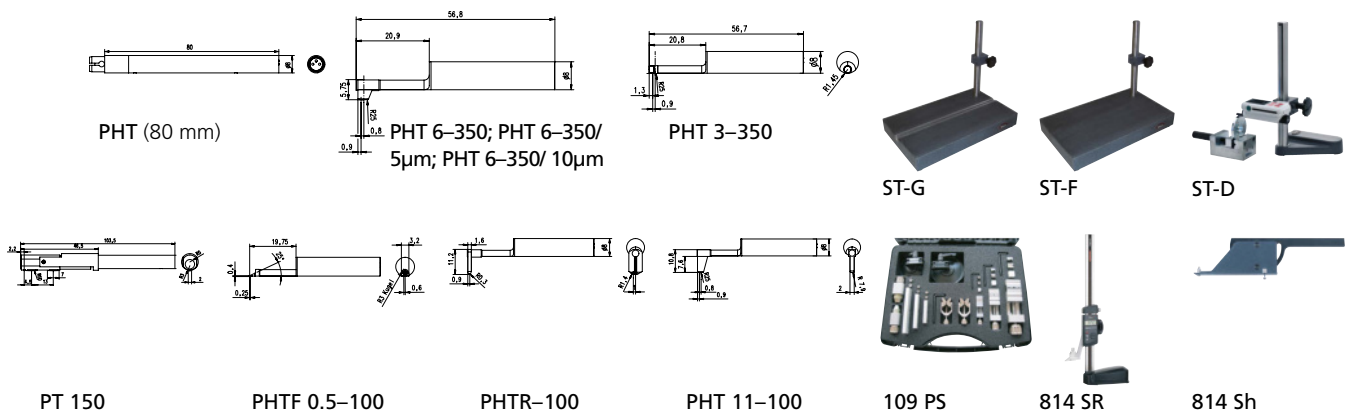

MarSurf M 310 PC

Mobile roughness measuring instrument

FEATURES

- Over 80 parameters for R-, P- and W-profiles according to current ISO/JIS or MOTIF standards (ISO 12085)
- Bandpass filter Ls in accordance with current standard; Ls can also be switched off or varied as required
- Comprehensive measuring records
- Quick and easy measuring programs can be created fast using teach-in methods
- Automatic function for choosing cut-off and traversing length in accordance with standards
- Support for various calibration methods (static and dynamic) by specifying the Ra or Rz parameter
- Adjustable maintenance and calibration intervals
- Multiple measuring station configurations for custom applications
- Range of options provide system flexibility
- Various user levels protect the device against misuse and prevent unauthorized people from using it
- Profile processing
- User-defined parameters
- QS-STAT
- QS-STAT Plus
- Dominant waviness
- ISO 13565-3 parameter
- Digital I/O
- MarSurf M 310 PC
- **Clever combination:**
The MarSurf M 310 & MarWin
- The MarSurf M 310 can be used as a drive unit together with MarWin Easy Roughness software. It can be easily connected to the computer by cable or Bluetooth wireless technology. This use combines the handiness of the Mahr M 310 with the wider range of functions of the software. It allows you to evaluate even more parameters and optimally analyze your measuring results without compromising on flexibility and ease of use. The PC-based instrument delivers all common thread parameters and profiles in accordance with international standards, both in the measuring room and in production. MarSurf M 310 PC from Mahr stands for innovative roughness evaluation software.

Package contents:

- Software MarWin Easy Roughness mobile incl. Mahr license key with standard license
- MarSurf M 310 Set, 2 µm probe tip

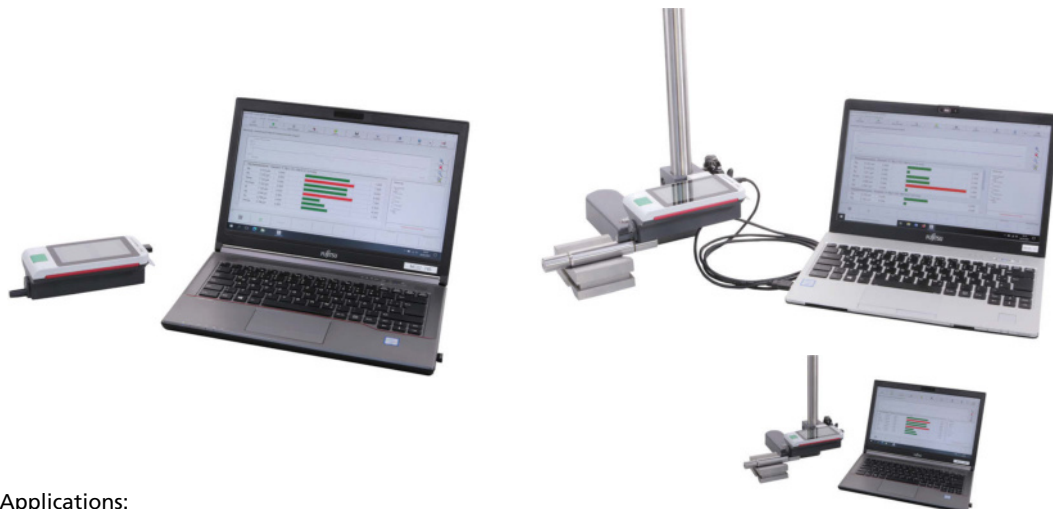

Applications:

Mechanical engineering

Bearings, shafts, racks, valves, various components from the engineering and precision engineering industry

Automotive industry

Steering, brake system, gearbox, crankshaft, camshaft, cylinder head, cylinder block, turbocharger

Medicine

Surface roughness measurement for hip and knee endoprostheses

Aerospace

Turbine components

Optics

Various optical components

TECHNICAL DATA

| Order no. | 6910295 | |
|--|--|--|
| Type | M 310 PC | |
| Measuring principle | Stylus method | |
| Probe | Inductive skidded probe | |
| Filter according to ISO/JIS | Gaussian filter as per ISO 16610-21 (formerly ISO 11562), special filter as per DIN EN ISO 13565-1, Ls filter as per DIN EN ISO 3274 (can be switched off) | |
| Cutoff f_c according to ISO/JIS | 0.25 mm, 0.8 mm, 2.5 mm, automatic filter detection, variable | |
| Number n of sampling length according to ISO/JIS | Selectable: 1 to 16 | |
| Short stroke under ISO/JIS | Selectable | |
| Traversing length according to ISO 12085 (MOTIF) | 1 mm, 2 mm, 4 mm, 8 mm, 12 mm, 16 mm | |

MarSurf M 310 PC

Mobile roughness measuring instrument

ACCESSORIES

| Order no. | Description | Type |
|------------|---|-----------------------|
| 3028620 | USB 2D scanner Honeywell Xenon 1900 | Handset scanner cable |
| 3028820 | 2D scanner Bluetooth Zebra DS2278 | Handset scanner BT |
| 3003856 | USB Bluetooth adapter | USB BT |
| 6910271 | Printer set for MarSurf M 310 | DP-B1 |
| 4102603 | Data cable USB bi-directional (2 m) | DK-U1 |
| 6850540 | PHT pick-up extension 80 mm | PHT (80 mm) |
| 6111520 | Standard probe 2 µm | PHT 6-350 |
| 6111526 | Standard probe 5 µm | PHT 6-350/ 5µm |
| 6111527 | Standard probe 10 µm | PHT 6-350/ 10µm |
| 6111521 | Probe for bores with a dia. larger than 3 mm | PHT 3-350 |
| 6111524 | Probe for grooves | PHT 11-100 |
| 6111525 | Probe for concave and convex surfaces | PHTR-100 |
| 6111522 | Probe for gear tooth flanks | PHTF 0.5-100 |
| 6111523 | Probe for metal sheets | PT 150 |
| 6850715 | Pick-up protection with header V-block, steel | PHT-ts4 |
| 7028530 | Pick-up protection header V-block, plastic | PHT-ts3 |
| 6910209 | Mount PS 10/M310 on measuring stand ST | ST-a3 |
| 6910435 | RD 18 C / PS 10 upright holder for cylindrical drive unit, Ø 8 mm | ST-a2 |
| 6710803 | Measuring stand 300 mm with cast iron base | ST-D |
| 6710806 | Measuring stand 300 mm with granite plate | ST-F |
| 6710807 | Measuring stand 300 mm with granite plate and T-slot | ST-G |
| 2247086 | Adjustable mounting bracket to connect to 814 SR | 814 Sh |
| 4426100 | Height measuring and scribing instrument, 0 -350 mm | 814 SR |
| 4426101 | Height measuring and scribing instrument, 0 -600 mm | 814 SR |
| 6710401 | V-block | PP |
| 6710604 | Parallel vice | PPS |
| 6710529 | XY Table | CT 120 |
| 4246819 | Set of miniature precision vises Set contents: mini-vises, jaw widths 15 / 25 / 35 mm, with tripod and V-blocks and miniature dividing attachments | 109 PS |
| 6820420 | Roughness standard with Mahr calibration certificate, profile depth 10 µm | PRN 10 |
| 4413000 | Measuring tripod with triangular pedestal 300 mm | 815 GN |
| 4413001 | Measuring tripod with triangular pedestal 500 mm | 815 GN |
| 4413005 | Measuring tripod with triangular pedestal 750 mm | 815 GN |
| 4416000 | Measuring tripod with magnetic base | 815 MA |
| 6299054 | Evaluation software | SW XR 20 |
| 6910240 | Protective films for LCD, real glass (3 pieces) | SF LCD |
| 6850500 | Magnetic fixture PS 10 / M 310 | MH |
| 6820521 | PS 10 gage / Geometric Standard incl. Mahr Calibration Certificate | PS 10 KN Mahr |
| 6800000DKS | Geometric standard, sinusoidal profile | MGs 1 |
| 6800000KAL | Geometric standard, sinusoidal profile | MGs 1 |
| 6800001DKS | Geometric standard, sinusoidal profile | MGs 3 |
| 6800001KAL | Geometric standard, sinusoidal profile | MGs 3 |
| 6800002DKS | Geometric standard, sinusoidal profile | MGs 10 |
| 6800002KAL | Geometric standard, sinusoidal profile | MGs 10 |

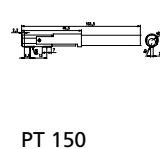
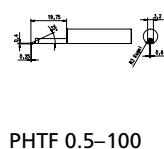
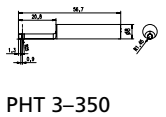
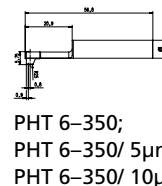
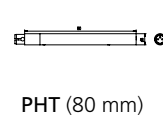
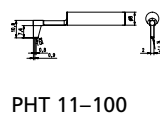
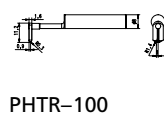

Twin pack with unlimited possibilities

Together with the BFW 250 probe system, the MarSurf M 400 evaluation instrument makes up an unbeatable twin pack: In addition to roughness profiles, highly accurate, standard waviness measurements can be carried out – location-independent in production or in measuring rooms. The reason for this is the integrated skidless probe system that allows a special depth depending on the probe arm – up to 30 mm in grooves, for example.

In addition, the handy tool can also be quickly combined with a number of probe arms without the use of tools thanks to the magnetic probe arm holder. The large selection also ensures that the broad measuring range is tripled from 500 μm to up to 1.500 μm .



Always keep track

With vibrant color display and simple user guidance, you can allocate your results anytime.

On-site documentation

Use the integrated thermal printer for profiles and results to print out your evaluations on site.

Flexible and mobile handling

Select the system that works for you: either wireless with Bluetooth connection or the wired version. Whatever you decide, you can always choose between plugging in to a power supply or using the battery, which means you never lose mobility.

Reliable metrology, reliable results

The highly precise probe system ensures that any skidless tracing as per ISO, JIS or ASME works. Complies with standard measuring point density at all times.



Short setup time, quick change

Due to the motorized height adjustment of the drive unit with automatic zero setting, all you need is a few seconds for setup. It is equally fast to change the probe arm thanks to the magnetic holder.

Scope of delivery (both sets):

- MarSurf M 400 evaluation instrument
- MarSurf SD 26 drive unit including BFW 250 probe system
- Standard probe arm (6852403)
- Thermal paper
- Wide-range power supply unit with 3 adapters
- 2 x USB cables (for connecting to the PC and for use with cable)
- Operating instructions
- Delivery in easy-to-handle transport case

MarSurf M 400

Mobile surface measuring instrument

FEATURES

MarSurf M 400. The best of the "mobiles"

- Surface evaluation using skidless tracing is not only needed in the measuring room but is required more and more in production as well.
- This usually means higher demands on operator qualities, more time, more adjustment work.
- In the line of "mobile surface metrology", MarSurf M 400 offers this required scope of performance and at the same time simple and fast operability.
- Mobile and stationary measuring instrument
- Roughness and waviness measurements
- Traversing lengths up to 26 mm
- Over 50 R, W and P surface parameters
- Automatic choice of cut-off and traversing length in accordance with international standards
- Dynamic calibration function
- Cable and Bluetooth connection between drive unit and evaluation instrument (4 m) (MarSurf M 400 C is only with cable connection)
- Magnetic probe holder (break away probe) BFW 250
- Motorized probe zero setting (max. 7.5 mm)

Supplied with:

- MarSurf M 400 evaluation instrument
- MarSurf SD 26 drive unit including BFW 250 probe system
- Standard probe arm (6852403)
- 1 roll of thermal paper
- Wide-range power supply unit with 3 adapters
- 2 USB cables (for connecting to the PC and the M 400)
- Operating instructions
- Case

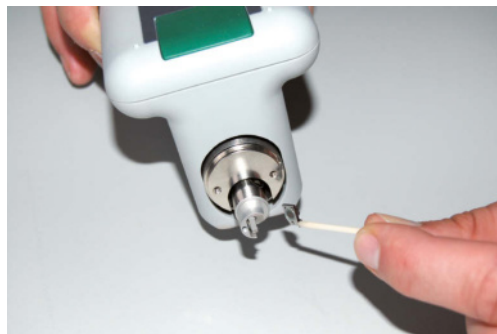
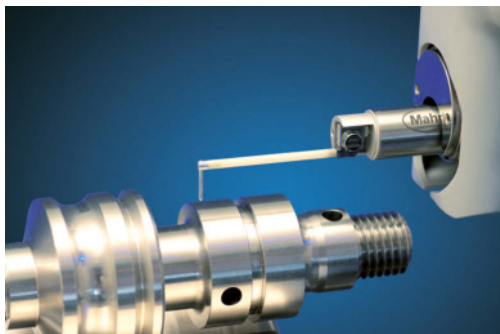

TECHNICAL DATA

| | |
|--|--|
| Measuring principle | Stylus method |
| Probe | BFW skidless system |
| Measuring range | +/-250 µm (up to +/-750 µm with 3x probe arm length) |
| Profile resolution | Measuring range +/-250 µm: 8 nm Measuring range +/-25 µm: 0.8 nm |
| Filter according to ISO/JIS | Gaussian filter as per ISO 11562 Filter as per ISO 13565 |
| Cutoff l_c according to ISO/JIS | 0.08 mm, 0.25 mm, 0.8 mm, 2.5 mm, automatical, variable |
| Number n of sampling length according to ISO/JIS | 1-5 |
| Contacting speeds | 0.2 mm/s; 1.0 mm/s |
| Measuring force | 0.75 mN |
| Positioning speed | 0.5; 1.0 |
| Surface parameters | Over 50 surface parameters for R, P and W profiles according to current ISO/JIS or MOTIF standards (ISO 12085) |

APPLICATIONS

Mechanical engineering

Bearings, shafts, racks, valves

Automotive industry

Steering, brake system, gearbox, crankshaft, camshaft, cylinder head, cylinder block, turbocharger

Steel industry

Measurement of sheet metal surfaces
Measurement of roller surface

Medicine

Surface roughness measurement for hip and knee endoprostheses

Aerospace

Turbine components

ACCESSORIES

Measuring stand

ST-D, ST-F and ST-G
Holder on measuring stand

Other accessories

CT 120 XY table, parallel vise, V-block
Assorted probe arms for the BFW probe system



For more information, please visit our website: www.mahr.com

MarSurf | PC-based stationary surface measuring stations

Versatile and powerful in measuring rooms and laboratories

PC-based surface measuring instruments represent the cutting edge in surface measurement and evaluation incorporating international standards, versatile evaluation methods, comprehensive documentation, large storage capacity, data export/import and networking with other systems. Extensive Quality Assurance procedures guarantee the highest quality and stability of software and hardware.



MarSurf CD 140 AG 11: Versatile with intelligent probe system

Mahr has launched a new contour measuring machine on the market – the MarSurf CD 140 AG 11. Its probe system has a measuring range of up to 70 mm and the stylus tips can be replaced quickly and without any tools – without having to recalibrate the system.

The new contour measuring machine MarSurf CD 140 AG 11 enables the user to complete fast and precise measurements. Its flexible workpiece holder makes it particularly easy to handle, while users are also convinced by its extreme versatility – it can also be used to measure roughness. The intelligent probe system and magnetic stylus tip holder ensure the process to replace stylus tips without any tools is the most straightforward process to date. Operators can also choose from a comprehensive range of clamps and workpiece holders. The new MarSurf CD 140 AG 11 can be used in a static position or directly at the location of the workpiece.

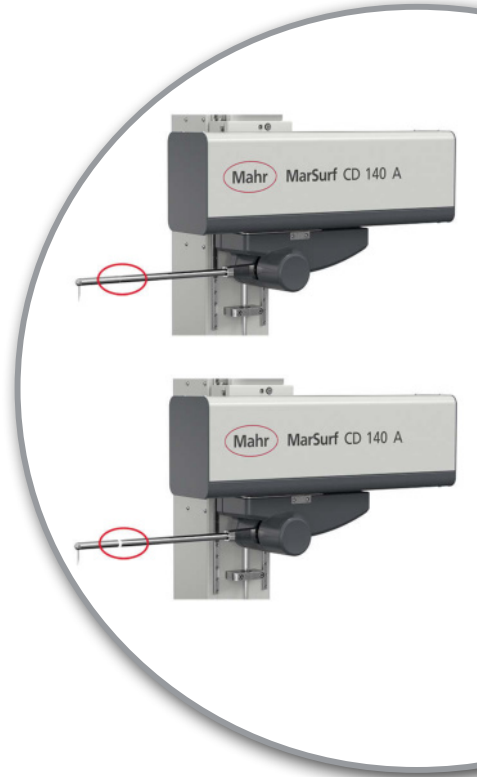

Advantages

- Comprehensive contour measurement functions – fast and simple
- Quick adjustment of the Z-axis with handles that are simple to operate
- Replacement of the stylus tip without any tools
- Travel speed in the X-axis of up to 200 mm/s
- Simple program creation or single measurement using MarWin
- Automatic evaluation, best adjustment of contours, CAD contour comparison, and a lot more
- Flexible support plate with 50 mm bore grid for KMG workpiece holder, amongst other
- Optionally expandable with option of roughness measurements ($R_z > 2 \mu\text{m}$)
- Measurement with double stylus

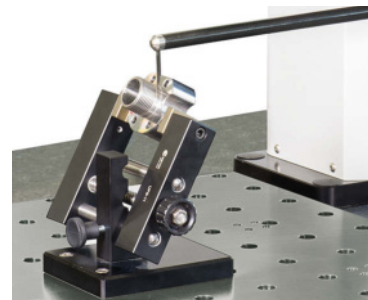
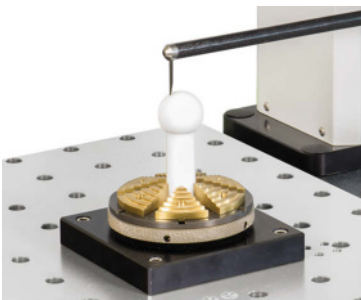

Plug-in guide stops and a wide range of standardized clamping devices as well as workpiece holders enable flexible positioning of your testpiece.

Manual quick adjustment

The fine adjustment is located in the Z-axis and moves the X-axis up and down.

Unique probe system

The probe system with a probe arm length of 350 mm enables a quick change of stylus tips without any tools and without having to recalibrate. The automatic tracing force selection guarantees the correct tracing force is selected when replacing several stylus tips.

X-axis with maximum measuring range

The high-speed X-axis is designed for a large measuring range of 140 mm.

Mahr MarSurf CD 140 A

Support plate also for large components

The 390 mm x 450 mm large plate with 50 mm matrix of holes is also suitable for large-volume workpieces. This provides a variety of flexible clamping options.

Generous traverse path

The Y-axis can be adjusted manually with a traverse path of 60 mm.

Ergonomic carrying handles

The handles on the side make it easy to transport the device.

MarSurf XR 1

Roughness measuring station

FEATURES

MarSurf XR 1 is the ideal instrument for a low-cost introduction to user-friendly surface metrology.

- The PC-based instrument delivers all common surface parameters and profiles in accordance with international standards, both in the measuring room and in production. MarSurf XR 1 from Mahr stands for innovative roughness evaluation software.
- Over 80 surface parameters for R-, P- and W-profiles according to current ISO/JIS or MOTIF standards (ISO 12085)
- Bandpass filter Ls in accordance with current standard; Ls can also be switched off or varied as required
- Comprehensive measuring records
- Teach-in methods for the rapid creation of Quick&Easy measuring programs
- Automatic functions for choosing cut-off and traversing length in accordance with standards
- Support for various calibration methods (static and dynamic) by specifying the Ra or Rz parameter
- Adjustable maintenance and calibration intervals
- Multiple measuring station configurations for custom applications
- Range of options provide system flexibility
- Various user levels protect the device against misuse and prevent unauthorized people from using it

Drive units and probe options:

- Skidded or skidless tracing
- Drive units MarSurf GD 26 and/or MarSurf SD 26 and/or MarSurf RD 18

Supplied with:

- MarSurf XR 1, MarWin EasyRoughness Software, Mahr license key with standard license
- Drive unit adapter
- All-in-one PC optional
- MarSurf SD 26 and/or RD 18 drive unit set including probe system
- MFW 250 B probe system set
- MarSurf ST-G measuring stand
- CT 120 XY table



TECHNICAL DATA

| XR 1 | |
|--|---|
| Type | XR 1 |
| Measuring principle | Stylus method |
| Probe | BFW skidless system with MarSurf SD 26 drive unit and/or PHT skidded system with MarSurf RD 18 drive unit |
| Measuring range | +/-250 µm (up to +/-750 µm with 3x probe arm length) applies to BFW system 350 µm applies to PHT probe system |
| Filter according to ISO/JIS | filter as per ISO 16610-21(replaced Gaussian filter as per ISO 11562), robust Gaussian filter a per ISO 16610-31 |
| Number n of sampling length according to ISO/JIS | 1 to 50 (default: 5) |
| Traversing lengths | MarSurf GD 26 / SD 26: Automatic; 0.56 mm*; 1.75 mm; 5.6 mm; 17.5 mm, 56 mm, Measurement up to stop, variable * Traversing length dependent on drive unit RD 18: Automatic; 1.75 mm; 5.6 mm; 17.5 mm |
| Measuring force | 0.75 mN |
| Surface parameters | Over 80 surface parameters for R, P and W profiles according to current ISO/JIS or MOTIF standards (ISO 12085) |

APPLICATIONS

Mechanical engineering

Bearings, shafts, racks, valves, various components from the engineering and precision engineering industry

Automotive industry

Steering, brake system, gearbox, crankshaft, camshaft, cylinder head, cylinder block, turbocharger

Medicine

Surface roughness measurement for hip and knee endoprostheses

Aerospace

Turbine components

Optics

Various optical components

ACCESSORIES

General software options:

- Dominant waviness (WDc) for MarWin
- ISO 13565-3 surface parameters
- QS-STAT / QS-STAT Plus
- Profile processing
- User defined parameters between operator and authorized personnel
- Contour 1 for MarSurf XR 1 / XR 20 (in conjunction with MarSurf SD 26 drive unit)
- Digital I/O set
- All options on one MLK



For more information, please visit our website: www.mahr.com

MarSurf GD 140 / GD 280

Roughness measuring station

FEATURES

Innovative technologies:

Fast axes

- Positioning speeds up to 200 mm/s in X
- 40 x faster than its predecessor MarSurf GD 120
- The Z-axis is fully CNC-capable by default
- The Z-axis is approx. twice as fast as previous Mahr Z-axes
- Up to 5 times faster than standard Z-axes on the market
- Contacting and zeroing via the Z-axis
- **New flexible probe system mount with BFW probe system**
- Simple probe arm change and probe arm protection by means of magnetic probe arm holder
- Probe arm holder allows the change from standard to transverse measurement without tools or adapters
- Extensions for the touch probe are possible
- **Innovative workpiece clamping system**
- Mounting plate 390 x 430 mm with bore dimension 50 mm
- Integrated 60 mm TY adjustment
- The combination of mounting plate and integrated TY adjustment makes an additional XY table superfluous
- Low workpiece setup supports a favorable short measurement loop, which has a positive effect on the measurement results

MarSurf GD: The new reference measuring station for roughness and waviness measurements

- The new Mahr measuring stations from the MarSurf GD series are setting new standards. In addition to surface roughness evaluations, profile, and waviness evaluations can also be performed. The new MarSurf GD series is enabling production companies to achieve a new dimension to reliably ensure and improve the production quality of workpieces in the measuring room or close to the production area.
- The new measuring station concept combines speed, security, and flexibility. The aim is to increase the cost-effectiveness of the system for your company.
- The measuring stations are operated with the user-friendly MarWin software (MarWin EasyRoughness or MarWin ProfessionalRoughness).



Applications:

Mechanical engineering

Bearings, threads, threaded bars, ball screws, shafts, racks

Production metrology

Contour measurement in a semi-automatic process

Automotive industry

Steering, brake system, gearbox, crankshaft, camshaft, cylinder head

Medical technology

Contour of hip and knee endoprosthesis, contour of medical screws, contour of dental implants

TECHNICAL DATA

| Order no. | 6269010 | 6269011 | 6269012 | 6269013 |
|--------------------|-----------------------------------|--|------------------|---------|
| Type | GD 140 | | GD 280 | |
| Probe | Roughness probe system (skidless) | | | |
| Measuring range | mm | 500 µm (±250 µm) for probe arm length 45 mm 1500 µm (±750 µm) for probe arm length 135 mm | | |
| Traversing lengths | | 0.1 mm to 140 mm | 0.1 mm to 280 mm | |
| Measuring force | N | 0.7 mN | | |
| Resolution | | Measuring range 1: 7.6 nm Measuring range 2: 0.76 nm | | |
| Measuring speed | | 0,02 mm/s to 10 mm/s | | |
| Positioning speed | | X: 0.02 mm/s to 200 mm/s Z: 0.02 mm/s to 50 mm/s | | |

ACCESSORIES

| Order no. | Description | Type |
|------------|--|-----------|
| 6821000 | Manual control panel | |
| 6710700 | Option motorized TY axes for basement | |
| 6820000 | Calibration standard with 2 balls | Contour B |
| 7003717 | Shock and vibration absorbing system for basement | |
| 6851345 | Control unit for standard shock and vibration absorbing system | |
| 6830144 | Instrument desk 1710 mm x 870 mm x 750 mm | Table |
| 7003789 | Table for absorbing system for basement | |
| 5356103 | Control panel with monitor | |
| 9026049 | Table top 740 x 430 set | |
| 6852551 | Probe system extension for BFW probe system length 150 mm | |
| 6852552 | Probe system extension for BFW probe system length 300 mm | |
| 6852553 | Probe system extension for BFW probe system length 500 mm | |
| 9000682 | Depth extension MarSurf GD/VD 140/280 | |
| 6820020 | Case of DK fixtures | DK |
| 6820001 | V-pieces set | AF 25 |
| 6820002 | Delta block set | AF 25 |
| 6820003 | Hold down set | AF 25 |
| 6820004 | Screw-jack set | Alufix |
| 6820005 | Three-jaw chuck set | Alufix |
| 680000KAL | Geometric standard, sinusoidal profile | MGs 1 |
| 680000DKS | Geometric standard, sinusoidal profile | MGs 1 |
| 680001KAL | Geometric standard, sinusoidal profile | MGs 3 |
| 680001DKS | Geometric standard, sinusoidal profile | MGs 3 |
| 680002KAL | Geometric standard, sinusoidal profile | MGs 10 |
| 680002DKS | Geometric standard, sinusoidal profile | MGs 10 |
| 6820901KAL | Roughness standard | MRS 1.5 |
| 6820901DKS | Roughness standard | MRS 1.5 |
| 6820903KAL | Roughness standard | MRS 3 |
| 6820903DKS | Roughness standard | MRS 3 |



For more information, please visit our website: www.mahr.com

The new MarSurf product family

Best performance and precise results in every sprint

With their extremely fast CNC axes and a highly dynamic probe system, machines from the MarSurf CD, MarSurf GD and MarSurf VD series break all speed records. Even when it comes to handling, the instruments are optimized to save your valuable time.

Easy changeover

The **magnetic mount** and **one-time calibration** mean that probe arms can be changed quickly and easily. This saves time when switching to a different measuring task.

Time-saving positioning

Just a few hand movements are required for flexible positioning of workpieces on the large support plate. Thanks to the 50 mm bore grid, the integrated TY-axis and the plug-in guide stops, your workpiece is in the correct position in a flash. **Set up your measuring station in half the time!**

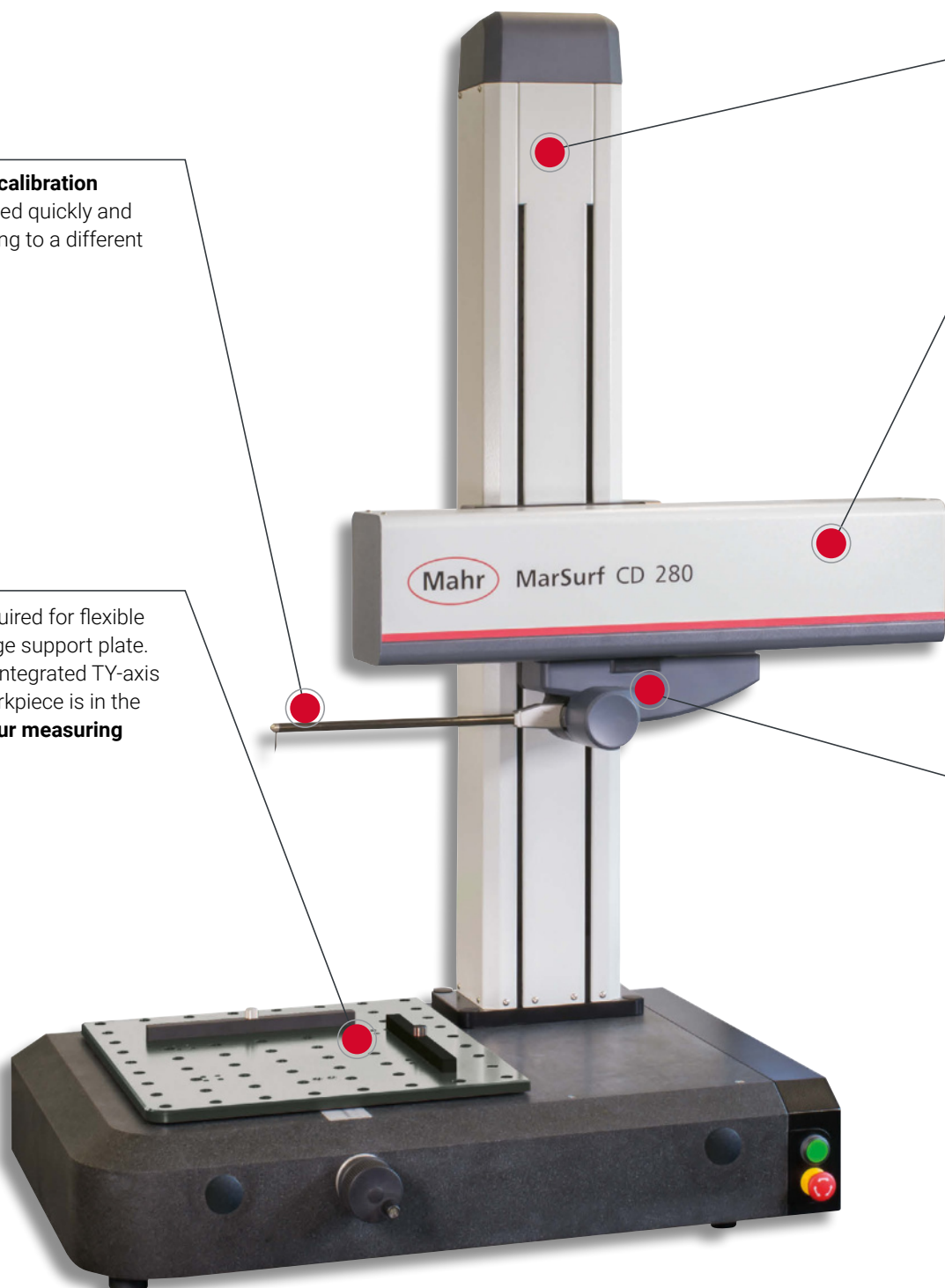

Quick axes

Z-axes with full CNC-capability and high-speed X-axes enable **positioning speeds of up to 50 mm/s in Z-direction and up to 200 mm/s in X-direction**. This means that the MarSurf instruments are particularly fast at getting to the start point of any measurement.

Short measuring times

The highly-dynamic probe system finds the perfect balance between rigidity and dynamics. **Which means you benefit from maximum accuracy at high measuring speeds of up to 10 mm/s.**

PERSONAL BEST!

Contour and surface measurement has never been as speedy as now. Our MarSurf CD 140 leads the way:

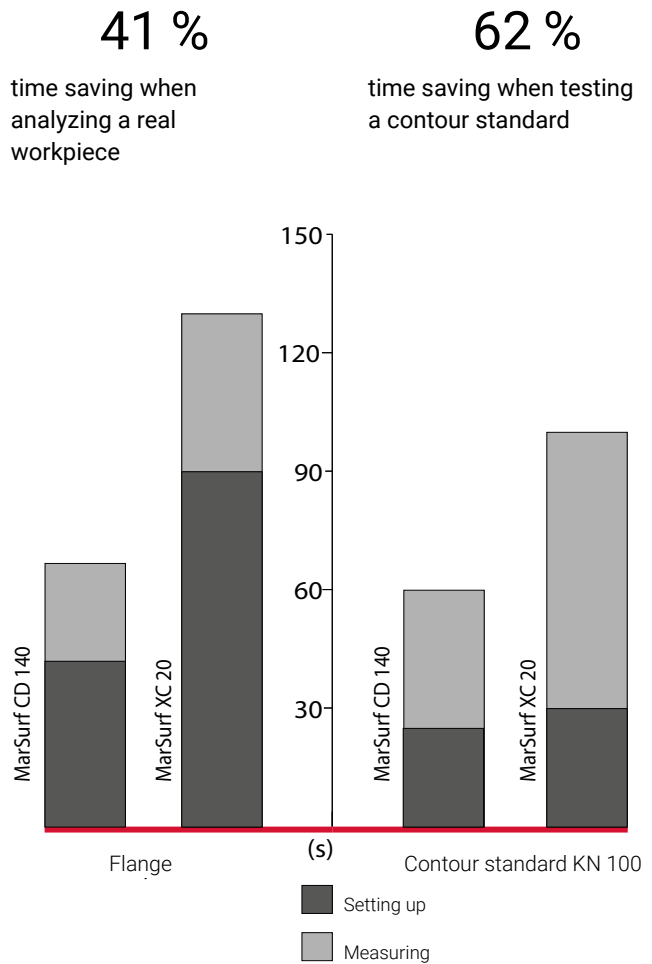

Ground-to-ground time of the new MarSurf CD 140 compared to a similar device.

MarSurf CD 140 A

Contour measuring station

FEATURES

- Traversing speed up to 200 mm/s in the x direction
- Quick adjustment of the Z-axis with easy-to-use handle
- Unique adjustment lock secures the adjusted measuring setup
- Fine adjustment for optimal alignment
- High speed measuring X-axis with 140 mm measuring range
- Integrated, manual 60 mm TY axis
- **Unique probe system**
- Tool-free quick change of probe tips saves time when changing over to another measuring task --> no recalibration required
- Magnetic probe holder
- Standard measuring range up to 70 mm
- Automatic measuring force selection guarantees the correct probe force when used in multiple stylus tip changes
- The low measuring force, starting at 4 mN, means that particularly "delicate" probe arms can be used, for example for small holes.
- Optional: Upgrade for roughness value determination
- **Innovative workpiece clamping system**
- Flexible support plate with 50 mm bore grid
- Integrated 60 mm TY adjustment
- The combination of support plate and integrated TY adjustment omits the need for an additional XY table
- A low workpiece setup supports an advantageous short measuring circuit, which has a positive effect on the measuring results
- A large support plate allows the workpiece to be positioned as required. This makes it easier to pick up larger parts.
- versatile with intelligent touch probe system
- Mahr has launched a new contour measuring machine on the market – its probe system has a measuring range of up to 70 mm and the stylus tips can be replaced quickly and without any tools – without having to recalibrate the system
- its enables the user to complete fast and precise measurements, its flexible workpiece holder makes it particularly easy to handle, while users are also convinced by its extreme versatility

Package contents:

- incl. 350 mm Z axis, 140 mm X axis, machine base with 50 mm hole grid and 60 mm Y adjustment
- Contact element PG A 36–350–25
- Software MarWin EasyContour



Applications:

Mechanical engineering

Bearings, threads, threaded rods, ball screws, shafts, racks

Measurement close to production

Contour measurement in a semi-automatic process

Automotive industry

Steering, brake system, transmission, crankshaft, camshaft, cylinder head

Medicine

Contour measurement for hip and knee endoprotheses, contour measurement for medical screws, contour measurement for dental implant

TECHNICAL DATA

| Order no. | 6269200 | 6269201 |
|-------------------|-------------------------|--|
| Type | CD 140 A | |
| H x W x D | mm | 572 x 905 x 822 mm |
| Probe | Contour probe system | |
| Measuring range | mm | 70 mm with probe arm length 350 mm |
| Measuring force | N | 4 mN to 30 mN, adjustable using software |
| Resolution | 19 nm | |
| Measuring speed | 0.1 mm/s to 10 mm/s | |
| Positioning speed | X: 0.1 mm/s to 200 mm/s | |

ACCESSORIES

| Order no. | Description | Type |
|-----------|---|-----------------------|
| 6820001 | V-pieces set | AF 25 |
| 6820002 | Delta block set | AF 25 |
| 6820003 | Hold down set | AF 25 |
| 6820004 | Screw-jack set | Alufix |
| 6820005 | Three-jaw chuck set | Alufix |
| 6820020 | Case of DK fixtures | DK |
| 6820021 | Quick release bracket with adapter plate | Alufix 25–50 |
| 6820022 | Quick release bracket swivel unit | +90°/–55° |
| 6820023 | Precision three-jaw chuck | 50 mm |
| 6820024 | Precision vise | 35 mm |
| 6820026 | Spring compressor with attachment for Vee block | 4 –50 mm |
| 6820027 | Quick release bracket angle element | 45° |
| 6820028 | Vee block 120°, 60 mm Vee block length | V-block |
| 6820010 | MarSurf standard holder | CD/GD/VD |
| 6830144 | Instrument desk 1710 mm x 870 mm x 750 mm | Table |
| 6710604 | Parallel vice | PPS |
| 6710401 | V-block | PP |
| 3028620 | USB 2D scanner Honeywell Xenon 1900 | Handset scanner cable |
| 3028820 | 2D scanner Bluetooth Zebra DS2278 | Handset scanner BT |

plus mobile

- Calibration standard contour B with two balls (45 mm and 6 mm) including Mahr calibration certificate



For more information, please visit our website: www.mahr.com

MarSurf CD 140 / CD 280

Contour measuring station

FEATURES

- Positioning speeds up to 200 mm/s in X
- 25x faster than the predecessors MarSurf PCV and MarSurf CD 120
- All measuring stations of this series have a fully CNC-capable Z-axis
- The Z-axis is approx. twice as fast as previous Mahr Z-axes
- Up to 5x faster than the X-axes usually found on the market
- **highly dynamic, intelligent probe system**
- Probe arm recognition via integrated chip
- Standard measuring range up to 70 mm; max. 100 mm with 490 mm probe arms
- Magnetic probe arm mount, probe arm change without tools
- The probe system combines robustness with dynamics
- Optional: Expansion for roughness evaluation
- **Innovative workpiece clamping system**
- Mounting plate 390 x 430 mm with bore size 50 mm
- Integrated 60 mm TY adjustment
- The combination of mounting plate and integrated TY adjustment omits the needs for an additional XY table
- Low workpiece set-up leads to an advantageously short measuring circuit, which positively affects the measuring results
- **Contour measuring in a new dimension**
- The new MarSurf CD series from Mahr sets new standards when it comes to contour testing. With the new MarSurf CD series, manufacturing companies are entering a new dimension in order to reliably secure and improve the manufacturing quality of workpieces in the measuring room or close to production.
- The new measuring station concept combines speed, reliability and flexibility. The aim is to increase the profitability of the system for your company



Applications:

Mechanical engineering

Bearings, threads, threaded rods, ball spindles, shafts, racks

Measurements close to production

Semi-automatic contour measurement

Automotive Industry

Steering, brake system, transmission, crankshaft, camshaft, cylinder head

Medical technology

Contour of the hip and knee endoprostheses, contour on medical screws, contour on dental implants

TECHNICAL DATA

| Order no. | 6269000 | 6269001 | 6269002 | 6269003 | 6269004 | 6269005 | 6269006 | 6269007 |
|--------------------|----------------------|--|---------|---------|------------------|---------|---------|---------|
| Type | CD 140 | | | CD 280 | | | | |
| Probe | Contour probe system | | | | | | | |
| Measuring range | mm | 70 mm with probe arm 350 mm long max. 100 mm with 490 mm long probe arm | | | | | | |
| Traversing lengths | | 0.1 mm to 140 mm | | | 0.1 mm to 280 mm | | | |
| Measuring force | N | 4 mN to 30 mN, adjustable via software | | | | | | |
| Resolution | | max. 6 nm (with 210 mm probe arm) | | | | | | |
| Measuring speed | | 0.02 mm/s to 10 mm/s | | | | | | |
| Positioning speed | | X: 0.02 mm/s to 200 mm/s Z: 0.02 mm/s to 50 mm/s | | | | | | |

ACCESSORIES

| Order no. | Description | Type |
|------------|--|-----------|
| 6821000 | Manual control panel | |
| 6710700 | Option motorized TY axes for basement | |
| 6820000 | Calibration standard with 2 balls | Contour B |
| 7003717 | Shock and vibration absorbing system for basement | |
| 6851345 | Control unit for standard shock and vibration absorbing system | |
| 6830144 | Instrument desk 1710 mm x 870 mm x 750 mm | Table |
| 7003789 | Table for absorbing system for basement | |
| 5356103 | Control panel with monitor | |
| 9026049 | Table top 740 x 430 set | |
| 6820020 | Case of DK fixtures | DK |
| 6820001 | V-pieces set | AF 25 |
| 6820002 | Delta block set | AF 25 |
| 6820003 | Hold down set | AF 25 |
| 6820004 | Screw-jack set | Alufix |
| 6820005 | Three-jaw chuck set | Alufix |
| 6820010 | MarSurf standard holder | CD/GD/VD |
| 6820125KAL | Contour standard | KN 100 |
| 6820125DKS | Contour standard | KN 100 |
| 6800001KAL | Geometric standard, sinusoidal profile | MGS 3 |
| 6800001DKS | Geometric standard, sinusoidal profile | MGS 3 |
| 6800002KAL | Geometric standard, sinusoidal profile | MGS 10 |
| 6800002DKS | Geometric standard, sinusoidal profile | MGS 10 |
| 6820903KAL | Roughness standard | MRS 3 |
| 6820903DKS | Roughness standard | MRS 3 |



For more information, please visit our website: www.mahr.com

MarSurf VD 140 / VD 280

Roughness and contour measuring station

FEATURES

- Positioning speeds up to 200 mm/s in X
- Contour measurements are 25x faster than with its predecessor MarSurf PCV or MarSurf CD 120
- Surface measurements are 40 x faster than with the MarSurf GD 120
- By default, the Z-axis is fully CNC-capable
- The Z-axis is approx. twice as fast as previous Mahr Z-axes
- Up to 5 times faster than standard Z-axes on the market
- **Two reference probe systems for your measuring tasks**
- **Contour probe system C 11**
- Probe arm recognition via integrated chip
- Standard measuring range up to 70 mm; Max. 100 mm with 490 mm probe arm length
- Magnetic probe arm holder, probe arm change without tools
- The touch probe combines robustness with dynamics
- Optional: Possibility to extend the roughness value determination to contours
- **Roughness probe system BFW**
- Easy probe arm change and probe arm protection by means of magnetic probe arm holder
- Probe arm mount allows the change from standard to transverse measurement without tools or adapter
- Extensions for the probe system possible
- **Innovative workpiece clamping system**
- Mounting plate 390 x 430 mm with hole dimension 50 mm
- Integrated 60 mm TY adjustment
- The combination of mounting plate and integrated TY adjustment makes an additional XY table superfluous
- Low workpiece setup supports a favorable short measurement loop, which has a positive effect on the measurement results
- **MarSurf VD Series - The MarSurf family is complemented:**
- The easy change between roughness and contour tracing system
- Depending on the measuring task, either the BFW roughness probe system for surface roughness or the C 11 contour probe system for contour measurements can be changed by the operator (hot-plug capable). The new system offers the advan-



TECHNICAL DATA

| Order no. | 6269020 | 6269021 | 6269022 | 6269023 |
|--------------------|---|--|------------------|---------|
| Type | VD 140 | | VD 280 | |
| Probe | Roughness probe system (skidless) Contour probe system | | | |
| Measuring range | mm | with roughness probe system 500 µm (±250 µm) for probe arm length 45 mm 1500 µm (±750 µm) for probe arm length 135 mm with contour probe system 70 mm with probe arm length 350 mm max. 100 mm with probe arm length 490 mm | | |
| Traversing lengths | | 0.1 mm to 140 mm | 0.1 mm to 280 mm | |
| Measuring force | N | with roughness probe system: 0.7 mN 4 mN to 30 mN, adjustable via software | | |
| Resolution | | with roughness probe system: Measuring range 1: 7.6 nm Measuring range 2: 0.76 nm with contour probe system: max. 6 nm (with 210 mm probe arm) | | |
| Measuring speed | | 0.02 mm/s to 10 mm/s | | |
| Positioning speed | | X: 0.02 mm/s to 200 mm/s Z: 0.02 mm/s to 50 mm/s | | |

- tages of combining the highly dynamic C 11 contour probe system with the high-precision BFW probe system, which is particularly suitable for fine surfaces.
- The new measuring station concept combines speed, reliability and flexibility.
 - The aim is to increase the profitability of the system for your company.
 - The measuring stations are operated with the user-friendly MarWin software (MarWin Easy Roughness & Contour or MarWin Professional Roughness & Contour).

APPLICATIONS

Mechanical engineering

Bearings, threads, threaded rods, ball screws, shafts, racks

Metrology close to production

Contour measurement in a semi-automatic process

Automotive industry

Steering, brake system, gearbox, crankshaft, camshaft, cylinder head

Medicine

Contour measurement for hip and knee endoprostheses, medical screws, dental implants

MarSurf VD 140 / VD 280

Roughness and contour measuring station

ACCESSORIES

| Order no. | Description | Type |
|------------|--|-----------|
| 6821000 | Manual control panel | |
| 6710700 | Option motorized TY axes for basement | |
| 6820000 | Calibration standard with 2 balls | Contour B |
| 7003717 | Shock and vibration absorbing system for basement | |
| 6851345 | Control unit for standard shock and vibration absorbing system | |
| 6830144 | Instrument desk 1710 mm x 870 mm x 750 mm | Table |
| 7003789 | Table for absorbing system for basement | |
| 5356103 | Control panel with monitor | |
| 9026049 | Table top 740 x 430 set | |
| 6852551 | Probe system extension for BFW probe system length 150 mm | |
| 6852552 | Probe system extension for BFW probe system length 300 mm | |
| 6852553 | Probe system extension for BFW probe system length 500 mm | |
| 9000682 | Depth extension MarSurf GD/VD 140/280 | |
| 6820020 | Case of DK fixtures | DK |
| 6820001 | V-pieces set | AF 25 |
| 6820002 | Delta block set | AF 25 |
| 6820003 | Hold down set | AF 25 |
| 6820004 | Screw-jack set | Alufix |
| 6820005 | Three-jaw chuck set | Alufix |
| 6820125KAL | Contour standard | KN 100 |
| 6820125DKS | Contour standard | KN 100 |
| 6800000KAL | Geometric standard, sinusoidal profile | MGS 1 |
| 6800000DKS | Geometric standard, sinusoidal profile | MGS 1 |
| 6800001KAL | Geometric standard, sinusoidal profile | MGS 3 |
| 6800001DKS | Geometric standard, sinusoidal profile | MGS 3 |
| 6800002KAL | Geometric standard, sinusoidal profile | MGS 10 |
| 6800002DKS | Geometric standard, sinusoidal profile | MGS 10 |
| 6820901KAL | Roughness standard | MRS 1.5 |
| 6820901DKS | Roughness standard | MRS 1.5 |
| 6820903KAL | Roughness standard | MRS 3 |
| 6820903DKS | Roughness standard | MRS 3 |



For more information, please visit our website: www.mahr.com

The universal contour and surface measuring system

Combined contour and roughness measurements can be excellently solved by the proven cutting-edge technology of Mahr metrology. The MarSurf LD 130 and MarSurf LD 260 measuring stations are characterized by consistent further development and integration of the experience gained from the first generation. Measuring tasks in the various applications increasingly demand the combination of contour and roughness determinations. In order to meet these requirements, the measuring instruments must demonstrate enormous metrological performance. Resolutions in the sub-nanometer range as well as residual noise of < 20 nm Rz are just some of the of the required ancillary conditions.

Innovative touch probe solution

Combined contour and roughness measurements, in one go, can be excellently solved by the proven top technology of Mahr metrology.

Easy change

The **magnetic mount** and **automatic stylus detection** allow a quick, easy change of stylus arms. This saves time when changing over to a different measuring task.

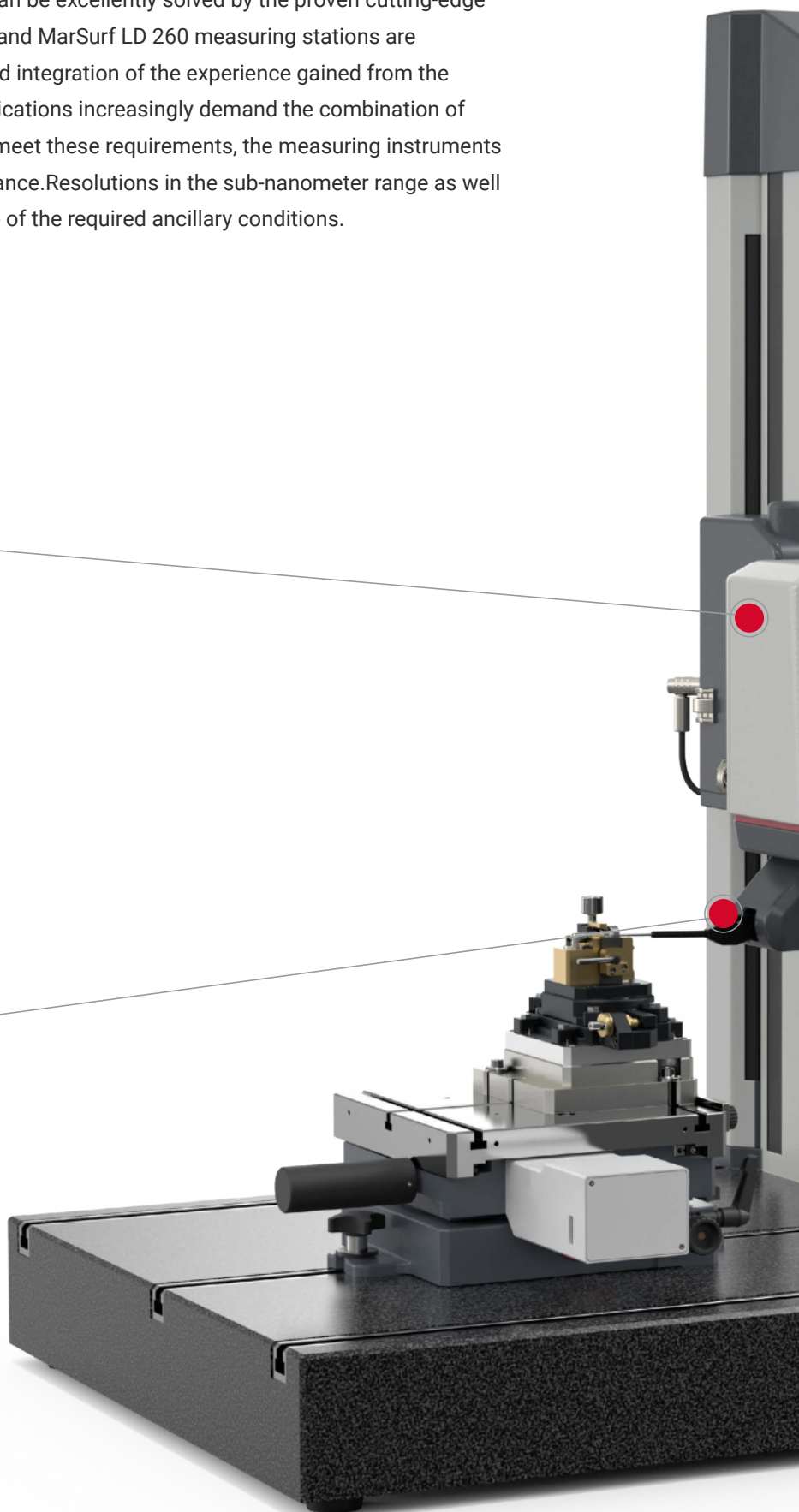



Fast axes

Fully CNC-capable axes allow positioning speeds of up to 200 mm/s. This enables the MarSurf devices to be particularly quickly positioned at the starting point of any measurement.

Reliable measurements

Bionic design of the probe arms and new materials ensure higher stiffness, lower vibration and higher dynamics.

MarSurf UD 130 / LD 130 / LD 260

Combined contour and surface measuring station

FEATURES

The MarSurf UD 130 closes the gap between the high-end solution MarSurf LD 130 / LD 260 and the new standard combination measuring station MarSurf VD 140 / 280 with two drive units. The technical specification of the MarSurf UD 130 is based on the high-quality interferometric probe system and the fast measuring and positioning speeds that have reduced the measuring times for each workpiece.

MarSurf LD 130 / LD 260. A step into a new dimension

- Combined contour and roughness measurements in just one step comes courtesy of proven cutting-edge technology from Mahr metrology. The MarSurf LD 130 and MarSurf LD 260 measuring stations have been systematically developed to draw on the experience from the first generation of equipment.
- Roughness and contour in just one step
- High measuring and positioning speed cuts measuring times dramatically
- Innovative probe system removal
- Quick and reliable probe arm exchange with simultaneous probe arm detection by magnetic holder
- Long measuring length up to 260 mm (MarSurf LD 260) with a measuring stroke of 13 mm (100 mm probe arm length) or 26 mm (200 mm probe arm length)
- Modular construction for ease of maintenance
- No need to fully dismantle the measuring stand for maintenance

Supplied with:

- MarSurf XCR 20 including midrange LD, MarWin software Easy Roughness & Contour, Mahr license key
- TFT monitor
- MCP 21 manual control panel
- MarSurf LD 130 or LD 260 drive unit including LP D 14–10–2/60 LP D 14–10–500 probe system and probe arms
- Calibration standard for contour 1, accuracy class 1
- MarSurf ST 500 CNC measuring stand with 700 mm x 550 mm granite plate (including control module)
- Dampening element set
- CT 300 XY table
- **MarSurf LD 130 / LD 260. A step into a new dimension**
- Combined contour and roughness measurements in just one step comes courtesy of proven

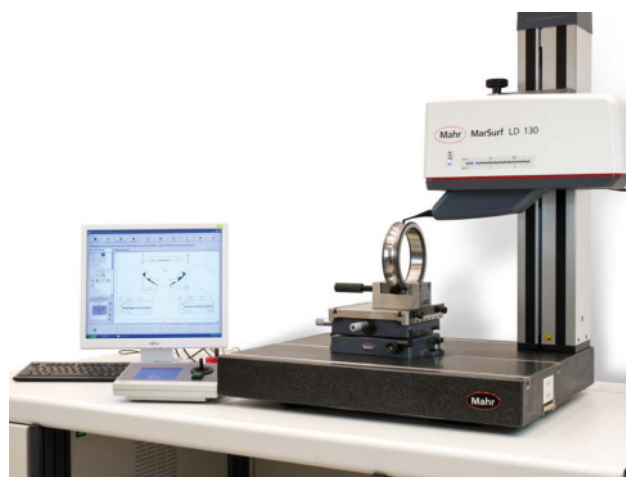

TECHNICAL DATA

| | UD 130 | LD 130 | LD 260 |
|--------------------|------------------------------------|--------------------------------------|--------------------------------------|
| Traversing lengths | 0.1 mm to 130 mm | 0.1 mm to 130 mm | 0.1 mm to 260 mm |
| Measuring force | 1 mN to 30 mN, software-adjustable | 0.5 mN to 30 mN, software adjustable | 0.5 mN to 30 mN, software-adjustable |
| Resolution | 2 nm | 0.8 nm | 0.8 nm |
| Measuring speed | 0.1 mm/s to 5 mm/s | 0.02 mm/s to 10 mm/s | 0.02 mm/s to 10 mm/s |
| Positioning speed | 0.1 mm/s to 30 mm/s | 0.02 mm/s to 200 mm/s | 0.02 mm/s to 200 mm/s |

APPLICATIONS

Mechanical engineering

Roller bearings, threads, threaded rods, ball screws, shafts, racks, ball heads, valves

Measurement close to the production area

Contour and surface roughness measurement in semi-automatic and fully automatic operation

Automotive industry

Engine parts including cylinder block, cylinder head, crankshaft, camshaft, valves, steering, gearbox, injection systems, turbocharger

Medicine

Contour and surface roughness measurement for hip and knee endoprostheses

Contour measurement for medical screws

Contour and surface roughness measurement for dental implants

Optics

Contour and surface roughness measurement of aspherical lenses

cutting-edge technology from Mahr metrology. The MarSurf LD 130 and MarSurf LD 260 measuring stations have been systematically developed to draw on the experience from the first generation of equipment.

- Roughness and contour in just one step
- High measuring and positioning speed cuts measuring times dramatically
- Innovative probe system removal
- Quick and reliable probe arm exchange with simultaneous probe arm detection by magnetic holder
- Long measuring length up to 260 mm (MarSurf LD 260) with a measuring stroke of 13 mm (100 mm probe arm length) or 26 mm (200 mm probe arm length)
- Modular construction for ease of maintenance
- No need to fully dismantle the measuring stand for maintenance

ACCESSORIES

- ST 750 measuring stand
- Parallel V-block
- V-block, equipment table
- Measuring cabinet
- Extensive range of probe arms
- Software options:
- Profile processing
- Dominant waviness (Wdc) for MarWin
- ISO 13565–3 surface parameters
- User defined parameters
- Topography
- Topography with MfM / MfM plus
- Thread Evaluation
- Chamfer evaluation (in accordance with Bosch standard)
- QS-STAT / QS-STAT Plus
- Digital I/O set

MarSurf CNC modular

FEATURES

The MarSurf CNC *modular* measuring stations are based on standard components. A standard surface measuring station can be expanded into a user-friendly, semi-automatic CNC measuring station simply by adding auxiliary table axes and possibly a measuring cabinet.



- Plug-and-play configuration of the control unit
- Easy to operate MarWin Software measuring wizard
- Universal concept for workpiece holder and clamp
- Minimal training required
- **Supplied with:**
- MarSurf LD 130 / LD 260 / UD 130 measuring station
- Including midrange CNC controller
- MarSurf ST 500 / 750 CNC measuring stand
- MCP 21 manual control panel

Optional table axes:

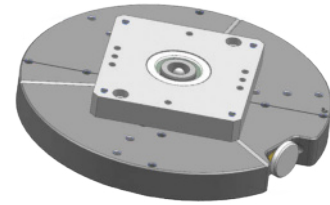
- T1S-L linear axis 200 mm
- T1S-R rotation axis
- T3S-LLR 3 table axes comprising 2 linear and one rotation axis
- **Optional measuring cabinet**



TECHNICAL DATA

| | |
|---|--|
|  | T1S-L Linear axis Complete with control module for midrange CNC Displacement path 200 mm Dimensions 510 mm x 200 mm x 200 mm Bearing strength 50 kg |
|  | T1S-R Rotation axis Complete with standard support plate and control module for midrange CNC For use as a TA or TC axis Dimensions 270 mm x 200 mm x 210 mm Bearing strength 30 kg |
|  | T3S-LLR 3 axis combination Complete with standard support plate and control module for midrange CNC Multiaxis, monolithic structure comprising axes TX, TY, TC Bearing strength 30 kg |

APPLICATIONS

Measurement close to the production area

- Pallet measurement
- Topography measurement
- Multiple measuring points on one part without reclamping
- Automatic X-axis alignment
- Universal measuring station for a wide variety of measuring tasks

ACCESSORIES

- Table plate with clamping sphere adapter and universal clamping plate
- Standard measuring station upgraded to MarSurf CNC *modular*



For more information, please visit our website: www.mahr.com

MarSurf | 3D surface metrology for industry and research

Optical analysis of surface topographies and geometries

Due to their versatility, MarSurf 3D measuring systems can be used in many areas of industry, from quality control to serial measurements. Within a few seconds, they deliver accurate and repeatable 3D measurements of almost any material – metals, glass, ceramics, semiconductors, polymers or organic materials.

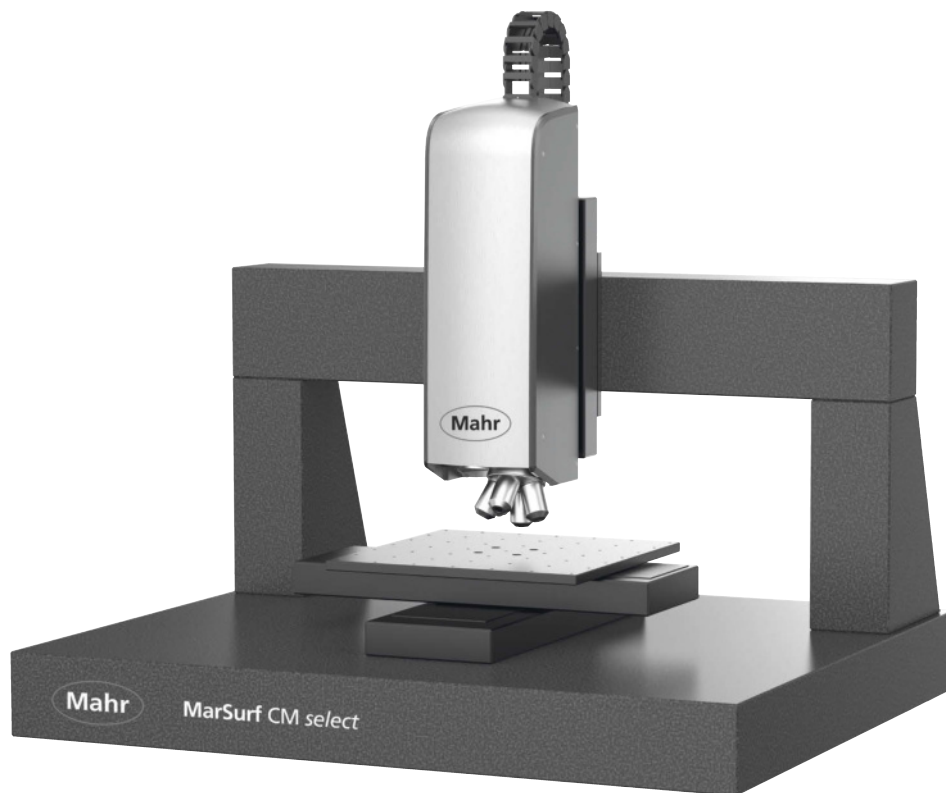

| | |
|---|------------|
| Overview MarSurf Surface measuring instruments | 552 |
| MarSurf CM <i>explorer</i> 3D surface measurement | 556 |
| MarSurf CM <i>expert</i> 3D surface measurement | 557 |
| MarSurf CM <i>mobile</i> 3D surface measurement | 558 |
| MarSurf CM <i>select</i> 3D surface measurement | 559 |
| MarSurf WI 50 M 3D surface measurement | 562 |
| MarSurf WI 50 3D surface measurement | 563 |
| MarSurf WI 100 3D surface measurement | 564 |
| MarSurf CP / CL <i>select</i> 3D profilometry | 568 |
| MarSurf 3D surface metrology - industries | 569 |

Optical or tactile?

Selecting the right measuring equipment

When should you rely on tactile metrology and when does it make more sense to measure using established optical devices? As both methods are equally precise, delivering results with 99 % accuracy, it always comes down to the surface structures you want to measure and which parameters are relevant for your production. Mahr offers you versatile solutions for both types of systems. The following criteria will help you make your selection:

1

Process values in accordance with ISO 4287, ISO 13565, ISO 25178 und ISO 21920

Tactile and optical devices identify the roughness and sometimes the waviness of surfaces – all the while in compliance with the standards DIN EN ISO 4287 and DIN EN ISO 13565. Optical devices also comply with the standard DIN EN ISO 25178 and in future with the standard DIN EN ISO 21920, which allow for an extensive description of a surface without contact.

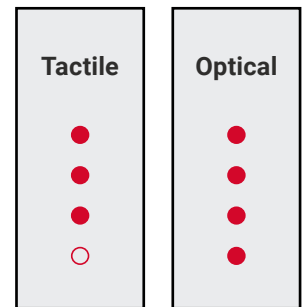

2

Get established process values in the blink of an eye

Roughness, waviness and primary profiles describe the surface and its properties. The parameters derived from that provide information about the quality of the surface. This guarantees reliability in the production process and makes it possible to carry out incoming goods checks quickly.

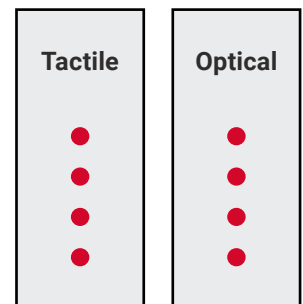

3

Statistical testing

When it comes to machined surfaces, structures are often no longer arranged in a certain direction but are distributed at random. A 2D section does not sufficiently describe them or, if it does, it is extremely time consuming. However, the extensive optical sampling of the surface provides more information and fast measuring results.

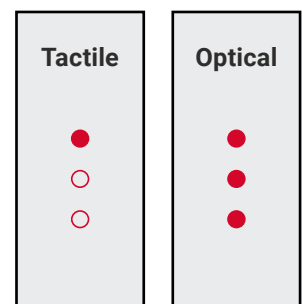



4

Measurement at the touch of a button

Simply place the probe arm on the surface, press the button and begin measurement – no need for complicated peripherals. Read the results directly on the display and print them out with the associated printer as desired. Enjoy all of this at an unbeatable price-performance ratio.

| Tactile | Optical |
|---------|---------|
| ● | ○ |
| ● | ○ |
| ● | ○ |
| ● | ○ |

5

Topological testing

When surfaces are extremely sensitive, soft, sticky or even discontinuous, non-contact and thus optical measurement is the method of choice. This applies equally to coated, inhomogeneous and complex surfaces as well as to surfaces without processing structures: It is best to scan and evaluate them optically.

| Tactile | Optical |
|---------|---------|
| ● | ● |
| ○ | ● |
| ○ | ● |
| ○ | ● |

6

Easy accessibility

Both optical and tactile mobile devices enable reliable surface testing directly on the workpiece in the production area. To examine surfaces, small depressions or drill holes that are difficult to access, the removable drive units in tactile tools also present a particular advantage.

| Tactile | Optical |
|---------|---------|
| ● | ● |
| ● | ● |
| ● | ○ |

Maximum signal quality thanks to multi-pinhole technology

Due to in-house developed and patented multi-pinhole technology, the powerful confocal microscopes in the MarSurf product line provide ultrafast image acquisition. This technology enables uniform random distribution as adjacent measuring points are not measured directly after one another. Beyond that, Mahr confocal microscopes set themselves apart due with their extremely low scatter and robust signaling at high light output. This allows you to achieve vertical resolutions into the nanometer range.

2_{nm}

Vertical optical resolution

99% CCF MAX

Maximum correlation to tactile measuring data

50,000_{MTBF}

LED light source

MPD technology

Artefact-free, quick, lowest noise figure, no preferential direction

TrueDetection technology

100-fold measuring point sampling, extremely stable measurements / repeatability

Piezo drive

for maximum vertical resolution

Objectives

Largest quadratic measuring fields, for roughness measurement in one measuring field / best homogenous lighting



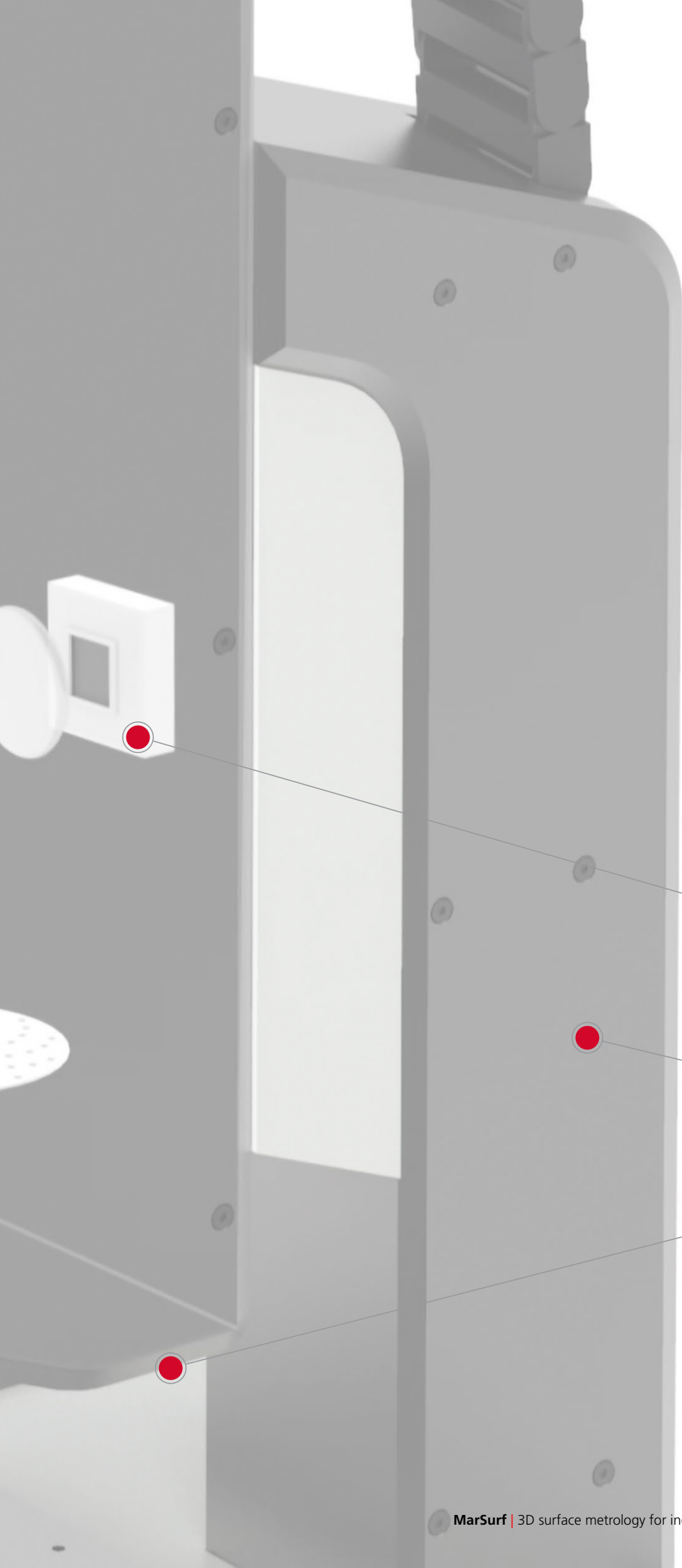

0.1 – 100 %

Reflectivity of all
sample surfaces

Measuring points per second

126,000,00

5_{sec}

Typical measuring time for 3D
roughness measurements

16-bit HDR camera

Optimal signal to noise ratio /
no increased noise with small
magnifications

Path length measuring system

Glass scales with path length
measuring system on all axes

Collision detection

in all directions – safe for
sample and system

MarSurf CM explorer

3D surface measurement

DESCRIPTION

The flexible, all-round measuring solution

The MarSurf CM *explorer* is a compact confocal microscope for the three-dimensional measurement and analysis of surfaces – **non-contact, material independent, and fast.**

The MarSurf CM *explorer* is suitable for use in test laboratories and equipped for quality assurance in production environments due to its robust construction and insensitivity to environmental influences.

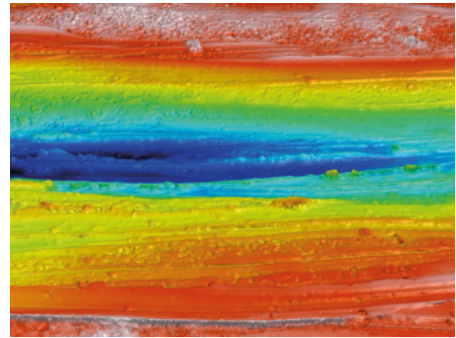

Key benefits:

- High measuring speed – even at full resolution
- User-friendly concept
- Safety through collision detection in all directions to protect your workpiece and measuring system
- High Dynamic Range (HDR) function, 16-bit
- Consistent high resolution output of large measuring surfaces due to HD stitching

This established optical measuring system is successfully used, for example, for:

- Roughness measurement according to DIN EN ISO 4287 / 25178
- Topography measurement (including volume, wear, isotropy)
- Measurement of microgeometry and layer thicknesses

Users value the MarSurf CM *explorer* as a reliable measuring system that provides quantitative traceable 3D characteristics for many industries.

TECHNICAL DATA

| CM explorer | |
|---------------------|---|
| Type | CM explorer |
| Measuring principle | Confocal High-performance LED (505 nm / white) |
| Resolution | up to 2 (nm) vertical |
| Measuring speed | up to 100fps |
| Surface parameters | ISO 4287, ISO 13565, ISO 25178, ... |

Supplied with: MarSurf CM *explorer*

- Confocal measuring head
 - HDR camera (B/W or color camera)
 - 4x lens revolver with identification
- L-tripod including control electronics
- Motorized XY table (50x50 mm) with glass scales for sample positioning and image field merging ("stitching")
- Motorized Z-axis (70 mm) with glass measuring scale
- Measuring system computer with 24" TFT monitor
- Objective lenses:
 - 5x to 100x selectable
- MarSurf MSW for intuitive data acquisition
- MarSurf MfM for professional evaluation, graphical representation and creation of measuring records (choice of Standard, Extended or Premium version)

APPLICATIONS

- **Mechanical engineering**
To qualify and quantify roughness, geometry and wear volume
- **Electronics and semiconductors**
Component inspection down to the sub-micrometer range for defect-free products
- **Medical technology**
Quality assurance of medical surfaces in production and laboratory
- **Material science**
Optimization of functional properties of new surfaces and products
- **Microsystems technology**
Measure complex surface geometries of smallest components with nanometer precision

MarSurf CM expert

3D surface measurement

DESCRIPTION

Automatable, high-end measuring system

The MarSurf CM *expert* is a powerful confocal microscope for the three-dimensional measurement and analysis of surfaces – **non-contact, material independent, and fast.**

The MarSurf CM *expert* is suitable for use in test laboratories and equipped for quality assurance in production environments due to its robust construction and insensitivity to environmental influences.

With additional manual Z positioning, a large x and y travel range and the possibility of automation, it offers excellent ease of use. The option of performing user-independent, fully automatic measurements makes this surface measuring system ideal for straightforward and efficient use in quality assurance.

Key benefits:

- User-independent serial measurements by automation software
- High measuring speed – even at full resolution
- User-friendly concept
- Safety through collision detection in all directions to protect your workpiece and measuring system
- High Dynamic Range (HDR) function, 16-bit
- Consistent high resolution output of large measuring surfaces due to HD stitching

This established optical measuring system is successfully used, for example, for:

- Roughness measurement according to DIN EN ISO 4287 / 25178
- Topography measurement (including volume, wear, isotropy)
- Measurement of microgeometry and layer thicknesses

Users value the reliability of this measuring system, which provides quantitative, traceable 3D characteristics for many industries.

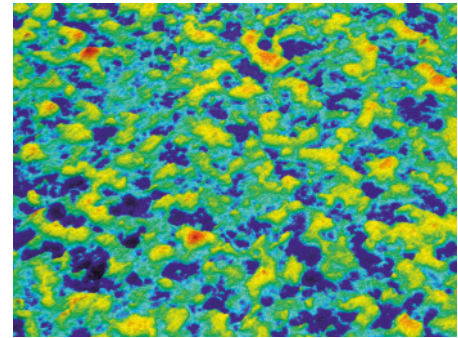

TECHNICAL DATA

| CM expert | |
|---------------------|--|
| Type | CM expert |
| Measuring principle | Confocal High-performance LED (505nm / white) |
| Resolution | up to 2 (nm) vertical |
| Measuring speed | up to 100fps |
| Surface parameters | ISO 4287, ISO 13565, ISO 25178, ... |

Supplied with: MarSurf CM expert

- Confocal measuring head
 - HDR camera (B/W or color camera)
 - 4x lens revolver with identification
- L-tripod including control electronics
- Motorized XY table (100x100 mm) with glass scales for sample positioning and image field merging ("stitching")
- Motorized Z-axis (70 mm) with glass measuring scale
- Measuring system computer with 24" TFT monitor
- Objective lenses:
 - 5x to 100x selectable
- MarSurf MSW for intuitive data acquisition
- MarSurf ASW for automation (optional)
- MarSurf MfM for professional evaluation, graphical representation and creation of measuring records (choice of Standard, Extended or Premium version)

APPLICATIONS

- **Mechanical engineering**
To qualify and quantify roughness, geometry and wear volume
- **Electronics and semiconductors**
Component inspection down to the sub-micrometer range for defect-free products
- **Medical technology**
Quality assurance of medical surfaces in production and laboratory
- **Material science**
Optimization of functional properties of new surfaces and products
- **Microsystems technology**
Measure complex surface geometries of smallest components with nanometer precision



For more information, please visit our website: www.mahr.com

MarSurf CM *mobile*

3D surface measurement

DESCRIPTION

Can be used everywhere

The compact MarSurf CM *mobile* is a portable confocal microscope for the three-dimensional measurement and analysis of surfaces – **non-contact, material independent, and fast.**

The low dead weight and operation via a laptop enable it to be used flexibly for measurement on large objects and difficult to move samples, such as rollers.

- Mobile use enables testing to be completed directly on the component/tool – even if the idle period is minimal
- Compact system (5kg) with motorized axes for HD stitching
- Robust and reliable for use in production
- High measuring speed – even at full resolution
- User-friendly concept
- Consistent high resolution output of large measuring surfaces due to HD stitching

This established optical measuring system is successfully used, or example, for:

- Roughness measurement according to DIN EN ISO 4287 / 25178
- Topography measurement (including volume, wear, isotropy)
- Measurement of microgeometry and layer thicknesses

Users value the MarSurf CM *mobile* as a reliable measuring system that provides quantitative traceable 3D characteristics for many industries .

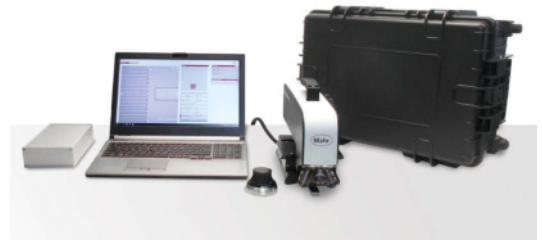

TECHNICAL DATA

| CM mobile | |
|---------------------|---|
| Type | CM <i>mobile</i> |
| Measuring principle | Confocal High-performance LED (505 nm) |
| Resolution | up to 2 (nm) vertical |
| Measuring speed | up to 100fps |
| Surface parameters | ISO 4287, ISO 13565, ISO 25178, ... |

Supplied with:
MarSurf CM *mobile*

- Confocal measuring head
 - B/W or Colour camera
 - 4x lens revolver
- Control electronics integrated in the system, HDR camera
- Motorized XY table (50x50 mm) with glass scales for positioning and image field merging ("stitching")
- Motorized Z-axis (35 mm)
- Laptop or measuring system computer with 24" TFT monitor selectable
- Objective lenses:
 - 5x to 100x selectable
- MarSurf MSW for intuitive data acquisition
- MarSurf MfM for professional evaluation, graphical representation and creation of measuring records (choice of Standard, Extended or Premium version)

APPLICATIONS

- **Mechanical engineering**
Qualification and quantification of the roughness, geometry, and wear volume
- **Tool technology**
Component inspection right in to sub-micrometer range for fault-free products
- **Medical technology**
Quality assurance of medical surfaces in production and the laboratory
- **Materials science**
Optimization of functional features on new surfaces and products
- **Microsystems technology**
Measurement of complex surface geometries of the smallest components with nanometer precision



For more information, please visit our website: www.mahr.com

MarSurf CM *select*

3D surface measurement

DESCRIPTION

Tailor-made measurement of surfaces

The MarSurf CM *select* is a powerful, configurable confocal microscope for the three-dimensional measurement and analysis of surfaces – **non-contact, material independent, and fast.**

Axes and isolation systems as well as software modules can be combined as needed. This allows the measuring system to be adapted to different measuring tasks.

As a multi-sensor system, the MarSurf CM *select* also offers the possibility of combining different sensor technologies in one measuring device. Depending on the measuring task, the optimal point sensor can also be flexibly selected.

The MarSurf CM *select* meets your individual requirements for automation, measuring comfort and accuracy – right up to the fully automated measuring solution.

Key benefits:

- Designed for continuous operation
- Automation software with industrial interfaces for transfer to QA systems
- High measuring speed – even at full resolution
- Individually configurable to your sample size
- Multi-sensor system
- User-friendly concept
- Safety through collision detection in all directions to protect your workpiece and measuring system
- High Dynamic Range (HDR) function, 16-bit
- Consistent high resolution output of large measuring surfaces due to HD stitching

This established optical measuring system is successfully used, for example, for:

- Roughness measurement according to DIN EN ISO 4287 / 25178
- Topography measurement (including volume, wear, isotropy)
- Measurement of microgeometry and layer thicknesses

Users value the reliability of this measuring system, which provides quantitative, traceable 3D characteristics for many industries.

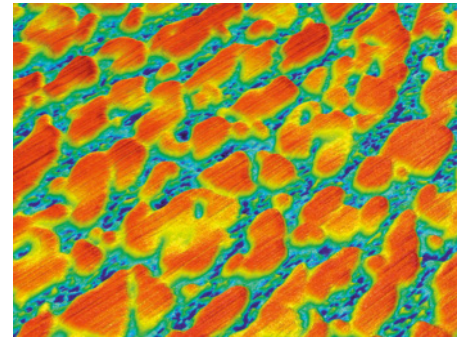

TECHNICAL DATA

| CM <i>select</i> | |
|---------------------|---|
| Type | CM <i>select</i> |
| Measuring principle | Confocal High-performance LED (505 nm / white) |
| Resolution | up to 2 (nm) vertical |
| Measuring speed | up to 100fps |
| Surface parameters | ISO 4287, ISO 13565, ISO 25178, ... |

Supplied with: MarSurf CM *select*

- Confocal measuring head
 - HDR camera (BW or color camera)
 - 4x lens revolver with identification (optional)
- Gantry design including control electronics
- Motorized XYZ axes available in different variants
- Industrial computer including two 24" TFT monitors
- Objective lenses:
 - 5x to 100x selectable
- Vibration damping system available
- Multi-sensor system (optional)
- Overview camera (optional)
- MarSurf MSW for intuitive data acquisition
- MarSurf ASW for automation (optional)
- MarSurf MfM for professional evaluation, graphical representation and creation of measuring records (choice of Standard, Extended or Premium version)

APPLICATIONS

- **Mechanical engineering**
To qualify and quantify roughness, geometry and wear volume
- **Electronics and semiconductors**
Component inspection down to the sub-micrometer range for defect-free products
- **Medical technology**
Quality assurance of medical surfaces in production and laboratory
- **Material science**
Optimization of functional properties of new surfaces and products
- **Microsystems technology**
Measure complex surface geometries of smallest components with nanometer precision



For more information, please visit our website: www.mahr.com

Measuring topographies in the sub-nanometer range

The Mahr white light interferometer series comprises three powerful tools: the MarSurf WI 50 M, the MarSurf WI 50 and the MarSurf WI 100. They score with a very large positioning volume and the intuitive user software that is known and highly esteemed by Mahr customers of optical.

Your advantages

- Use of both phase information and amplitude
- Minimal noise figure
- High precision
- Maximum stability

Powerful ICA technology

The white light interferometer by Mahr is based on a novel algorithm that combines the best properties of traditionally used methods like PSI and VSI in a singular broad range of applications.

This algorithm searches for the best correlation and for this purpose compares each individual pixel. The resulting height values are very precise and robust. This minimizes the noise, which in consequence leads to a uniquely high data quality.

Hereby laboratories and quality assurance can determine the smallest roughness values, step heights or flatness in the nanometer range – all within a matter of seconds.

VDI/VDE 2655 | ISO 25178

Certified system acceptance

Low SNR

Signal-to-noise-ratio as standard

Up to 5 MP

High lateral resolution with maximum number of pixels

ICA technology

Intelligent Correlation Algorithm as standard

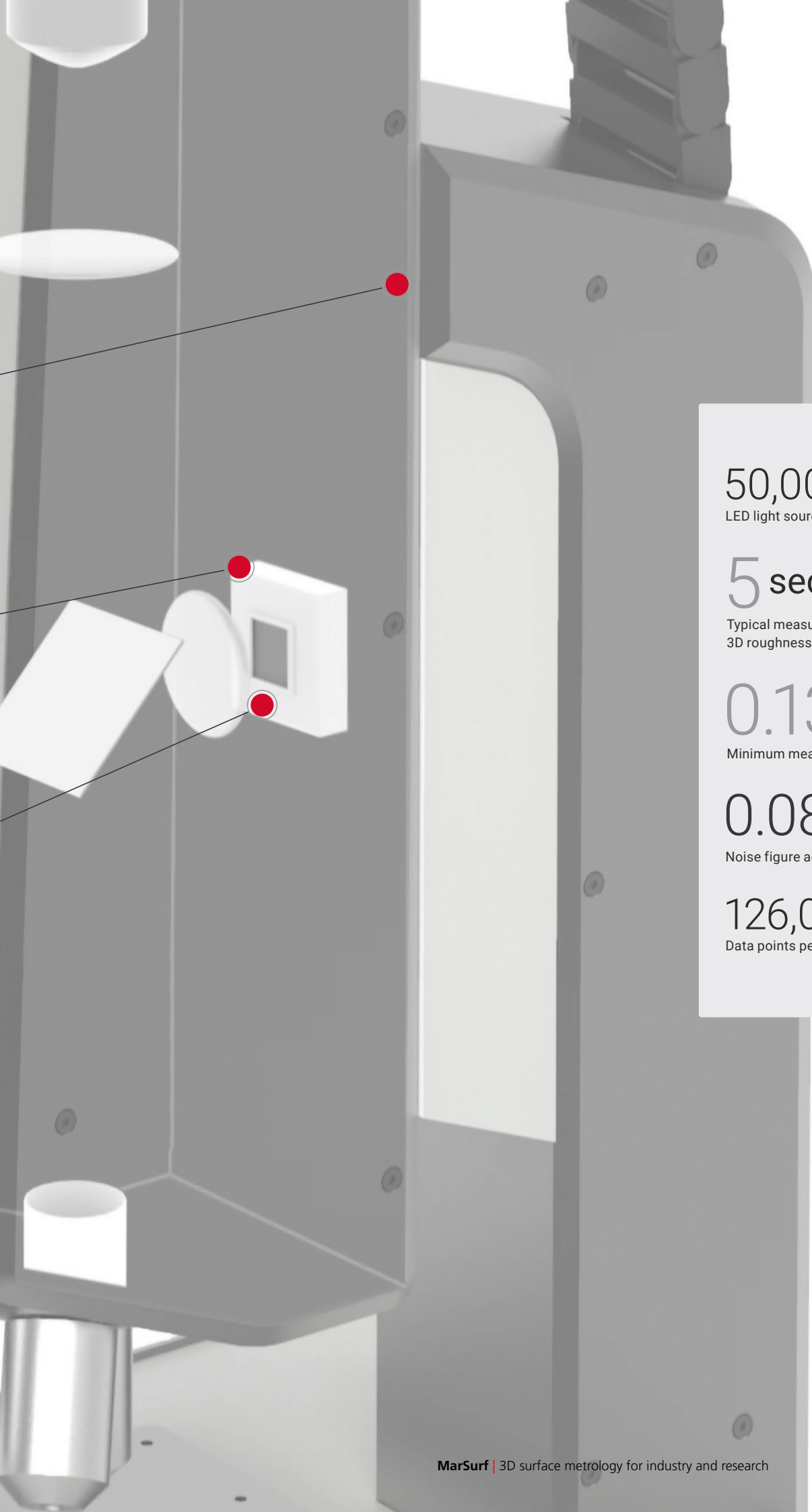

50,000 MTBF
LED light source

5 sec.
Typical measuring time for a
3D roughness measurement

0.13 μm
Minimum measuring point level

0.08 Nanometer
Noise figure according to STR

126,000,000
Data points per second

MarSurf WI 50 M

3D surface measurement

DESCRIPTION

High-performance entry-level solution

The MarSurf WI 50 M is a white light interferometer for the three-dimensional measurement and analysis of surfaces – **non-contact, material independent, and fast.**

Precise measurement in the sub-nanometer range – simple with the new MarSurf WI 50 M, the perfect entry-level solution. The system meets all the requirements of your measuring tasks in the nanometer range – offering maximum performance and outstanding value for money. Adjustment and focusing are child's play thanks to the functional tilting table and manual X-, Y- and Z-axes.

Key benefits:

- Simple technology without motorized axes
- Intuitive operation
- Fast measurements
- Cost-effective
- Robust and reliable
- Max. sample height 220 mm
- Control unit integrated in tripod

This new optical measuring system is successfully used, for example, for:

- Roughness measurement according to DIN EN ISO 4287 / 25178
- Topography measurement (including volume, wear, isotropy)
- Measurement of microgeometry and layer thicknesses

Users value the reliability of MarSurf series measuring systems as they provide quantitative, traceable 3D parameters for many industries.

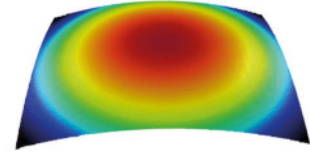

TECHNICAL DATA

| WI 50M | |
|---------------------|--|
| Type | WI 50 M |
| Measuring principle | White Light Interferometer High-performance LED (650 nm / white) White light interferometer High-power LED (650 nm / white) |
| Resolution | up to 0.2 (nm) vertical |
| Measuring speed | up to 140 fps |
| Surface parameters | ISO 4287, ISO 13565, ISO 25178 ... ISO 4287, ISO 13565, ISO 25178 ... |

Supplied with: MarSurf WI 50

- Interferometric measuring head – HDR camera (2 MP or 5 MP)
- L-tripod including control electronics
- Motorized XY table (105x220 mm)
- Manual Z-axis (220 mm)
- Measuring system computer with 24" TFT monitor
- Objective lenses: – 2.5x to 100x selectable
- MarSurf MSW for intuitive data acquisition
- MarSurf MfM for professional evaluation, graphical representation and creation of measuring records (choice of Standard, Extended or Premium version)

APPLICATIONS

- **Mechanical engineering**
Qualification and quantification of the roughness, geometry, and wear volume
- **Electronic system and semiconductors**
Component inspection right down to sub-nanometer range for fault-free products
- **Medical technology**
Quality assurance of medical surfaces in production and the laboratory
- **Materials science**
Optimization of functional features on new surfaces and products
- **Microsystems technology**
Measurement of complex surface geometries of the smallest components with nanometer precision



For more information, please visit our website: www.mahr.com

MarSurf WI 50

3D surface measurement

DESCRIPTION

The flexible, all-round measuring solution

The MarSurf WI 50 is a compact white light interferometer for the three-dimensional measurement and analysis of surfaces – **non-contact, material independent, and fast.**

Allrounder-measurement solutions, flexible at all times, exactly where it comes down to the sub-nanometer: this is what the new MarSurf WI 50 stand for. These high-precision measurement tools for research and quality assurance deliver reliable 3D measuring data – quickly and straightforward in very few steps.

Key benefits:

- High measuring speed – even at full resolution
- CNC-functionality for all axes
- Safety through collision detection in all directions to protect your workpiece and measuring system
- High Dynamic Range (HDR) function, 16-bit
- HD-stitching: Consistent high resolution output of large measuring surfaces

This established optical measuring system is successfully used, for example, for:

- Roughness measurement according to DIN EN ISO 4287 / 25178
- Topography measurement (including volume, wear, isotropy)
- Measurement of microgeometry and layer thicknesses

Users value the reliability of this measuring system, which provides quantitative, traceable 3D characteristics for many industries.

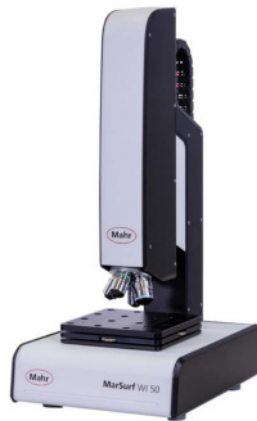

TECHNICAL DATA

| WI 50 | |
|---------------------|---|
| Type | WI 50 |
| Measuring principle | White light interferometer High-power LED (650 nm / white) |
| Resolution | up to 0.2 (nm) vertical |
| Measuring speed | up to 140 fps |
| Surface parameters | ISO 4287, ISO 13565, ISO 25178 ... |

Supplied with: MarSurf WI 50

- Interferometric measuring head
 - HDR camera (2 MP or 5 MP)
 - 4x lens revolver with identification
- L-tripod including control electronics
- Motorized XY table (50 x 50 mm) with glass scales for sample positioning and image field merging ("stitching")
- Motorized Z-axis (70 mm) with glass measuring scale
- Measuring system computer with 24" TFT monitor
- Objective lenses:
 - 2.5x to 100x selectable
- MarSurf MSW for intuitive data acquisition
- MarSurf MfM for professional evaluation, graphical representation and creation of measuring records (choice of Standard, Extended or Premium version)

APPLICATIONS

- **Mechanical engineering**
Qualification and quantification of the roughness, geometry, and wear volume
- **Electronic system and semiconductors**
Component inspection right down to sub-nanometer range for fault-free products
- **Medical technology**
Quality assurance of medical surfaces in production and the laboratory
- **Materials science**
Optimization of functional features on new surfaces and products
- **Microsystems technology**
Measurement of complex surface geometries of the smallest components with nanometer precision



For more information, please visit our website: www.mahr.com

MarSurf WI 100

3D surface measurement

DESCRIPTION

Automatable, high-end measuring system

The MarSurf WI 100 is a powerful white light interferometer for the three-dimensional measurement and analysis of surfaces – **non-contact, material independent, and fast.**

Allrounder-measurement solutions, flexible at all times, exactly where it comes down to the sub-nanometer: this is what the new MarSurf WI 100 stand for. These high-precision measurement tools for research and quality assurance deliver reliable 3D measuring data – quickly and straightforward in very few steps. With additional manual Z positioning, a large x and y travel range and the possibility of automation, it offers excellent ease of use. The option of performing user-independent, fully automatic measurements makes this surface measuring system ideal for straightforward and efficient use in quality assurance.

Key benefits:

- User-independent serial measurements by automation software
- High measuring speed – even at full resolution
- User-friendly concept
- Safety through collision detection in all directions to protect your workpiece and measuring system
- High Dynamic Range (HDR) function, 16-bit
- HD-stitching: Consistent high resolution output of large measuring surfaces

This established optical measuring system is successfully used, for example, for:

- Roughness measurement according to DIN EN ISO 4287 / 25178
- Topography measurement (including volume, wear, isotropy)
- Measurement of microgeometry and layer thicknesses

Users value the reliability of this measuring system, which provides quantitative, traceable 3D characteristics for many industries.

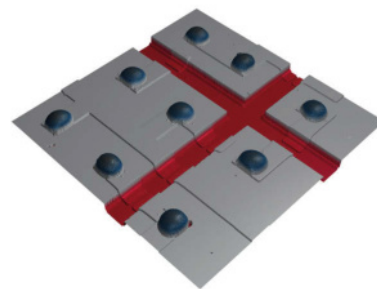

TECHNICAL DATA

| Order no. | Type | Other | Power supplied | Measuring principle | Resolution | Measuring speed |
|-----------|--------|--------------------------------------|----------------|---|-------------------------|-----------------|
| 6355002 | WI 100 | Collision detection in xyz direction | 100 –240 V | White light interferometer High-power LED (650 nm / white) | up to 0.2 (nm) vertical | up to 140 fps |
| 6355005 | WI 100 | Collision detection in xyz direction | 100 –240 V | White light interferometer High-power LED (650 nm / white) | up to 0.2 (nm) vertical | up to 140 fps |

Package contents: MarSurf WI 100

- Interferometric measuring head – HDR camera (2 MP or 5 MP) – 4x lens revolver with identification L-tripod including control electronics
- Motorized XY table (100 x 100 mm) with glass scales for sample positioning and image field merging ("stitching")
- Motorized Z-axis (70 mm) with glass measuring scale
- Additional manual Z-Axis (100 mm)
- Measuring system computer with 24"-TFT-monitor
- Objective lenses: – 2.5x to 100x selectable
- MarSurf MSW for intuitive data acquisition
- MarSurf ASW for automation (optional)
- MarSurf MfM for professional evaluation, graphical representation and creation of measuring records (choice of Standard, Extended or Premium version)

APPLICATIONS

- **Mechanical engineering**
Qualification and quantification of the roughness, geometry, and wear volume
- **Electronic system and semiconductors**
Component inspection right down to sub-nanometer range for fault-free products
- **Medical technology**
Quality assurance of medical surfaces in production and the laboratory
- **Materials science**
Optimization of functional features on new surfaces and products
- **Microsystems technology**
Measurement of complex surface geometries of the smallest components with nanometer precision



For more information, please visit our website: www.mahr.com

ACCESSORIES

| Order no. | Description | Type |
|------------|---|---------|
| 6820431 | Depth standard Pt 0.2–0.4 µm, 1 µm | MDS 1 |
| 6820431DKS | Depth standard Pt 0.2–0.4 µm, 1 µm | MDS 1 |
| 6820431KAL | Depth standard Pt 0.2–0.4 µm, 1 µm | MDS 1 |
| 6820430 | Depth standard Pt 1 / 4 / 9 µm | MDS 9 |
| 6820430DKS | Depth standard Pt 1 / 4 / 9 µm | MDS 9 |
| 6820430KAL | Depth standard Pt 1 / 4 / 9 µm | MDS 9 |
| 6820901 | Roughness standard | MRS 1.5 |
| 6820901DKS | Roughness standard | MRS 1.5 |
| 6820901KAL | Roughness standard | MRS 1.5 |
| 6820903 | Roughness standard | MRS 3 |
| 6820903DKS | Roughness standard | MRS 3 |
| 6820903KAL | Roughness standard | MRS 3 |
| 9040597 | Flatness standard incl. PTB certificate | FtS |
| 9040596 | Flatness standard | FtS |
| 9040594 | Line scale 10/25/100/250 µm | LS |
| 9040595 | Line scale 10/25/100/250 µm DAkkS | LS |

Flexible 3D profilometer for quality control

The MarSurf CP /CL select 3D profilometer has proven itself many times over when measuring topography, line roughness, height profiles or layer thickness in the production process. Its modular design and ability to combine with different sensors mean that it can adapt to many different measuring tasks. The manual Z-adjuster with fine adjustment guarantees extreme ease of use. Alternatively, there is also a motorized Z-axis. The setup on granite and the use of top-quality components guarantee high repeatability of measurements. It is also possible to measure large and heavy samples.

Point sensors

Sensors with vertical measuring ranges from 0.1 to 10 mm depending on the application as well as high vertical resolution with an optimized signal-to-noise ratio

X-Y axes

available in different sizes



Solid construction

for optimal measuring results / stability



Multi-sensor setup

e.g. for measuring roughness and contours in the millimeter range

Measuring range expansion

of large areas and structure heights in the millimeter range. Typical measuring tasks include flatness, deflection, line roughness, contour and height profile.

Bridge portals

can be individually configured in all sizes

Overview camera

for flexibly teaching measurements

2D and 3D

Measuring 2D and 3D parameters and structures

MarSurf CP / CL select

3D profilometry

DESCRIPTION

Optical 2D/3D profilometry

The MarSurf CP and MarSurf CL *select* are optical profilometers used to complete two- and three-dimensional measurement and analysis of surfaces – **non-contact, material independent, and fast.**

They stand out for extremely fast recording of large measuring surfaces while also ensuring high measuring precision.

Thanks to its modular design, the measuring systems can be adjusted to various measuring tasks and individual automation, measuring convenience, and accuracy requirements. Depending on the measuring task, different sensors can be selected flexibly. Axes systems as well as software modules can be combined individually.

The MarSurf CP and CL *select* meet your individual requirements for automation, measuring comfort and accuracy – right up to the fully automated measuring solution.

- Large scale 3D measurements
- Very high measuring speed
- User-independent serial measurements by automation software
- Excellent flank acceptability
- Layer thickness measurement und measurement of transparent materials
- Large height measurement range with large working distance
- Robust and reliable
- User-friendly concept

This established optical measuring system is successfully used, for example, for:

- Roughness measurement according to DIN EN ISO 4287
- Topography measurement (including volume, wear, isotropy)
- Measurement of macro and micro geometries
- Determination of flatness and coplanarity

Users value the MarSurf CP and CL *select* series as reliable measuring systems that provide quantitative, traceable 2D/3D characteristics for many industries.

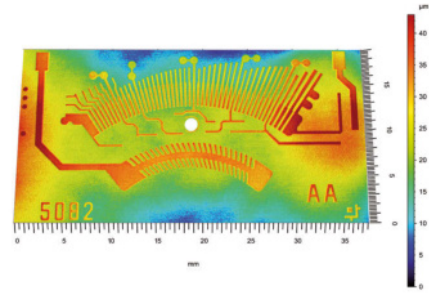

TECHNICAL DATA

| CP select | |
|---------------------|-------------------------------------|
| Type | CP / CL <i>select</i> |
| Measuring principle | Chromatic-confocal |
| Measuring speed | 4 kHz |
| Surface parameters | ISO 4287, ISO 13565, ISO 25178, ... |

Supplied with: MarSurf CP *select*

- Chromatic point sensors selectable
- Portal construction including control electronics, model selectable
- Motorized XYZ table selectable in different variants
- Industrial computer incl. two 24" TFT monitors
- Vibration damping selectable
- Overview camera selectable
- MarSurf MSW for intuitive data acquisition
- MarSurf ASW for automation (optional)
- MarSurf MfM for professional evaluation, graphic presentation and creation of measuring records (Standard, Extended, Premium version selectable)

MarSurf CL *select*

- Chromatic line sensors selectable
- Portal construction including control electronics, model selectable
- Motorized XYZ table selectable in different variants
- Industrial computer incl. two 24" TFT monitors
- Vibration damping selectable
- Overview camera selectable
- MarSurf MSW for intuitive data acquisition
- MarSurf ASW for automation (optional)
- MarSurf MfM for professional evaluation, graphic presentation and creation of measuring records (Standard, Extended, Premium version selectable)

APPLICATIONS

- **Mechanical engineering**
To qualify and quantify roughness, geometry and wear volume
- **Electronics and semiconductors**
Component inspection down to the sub-micrometer range for defect-free products
- **Medical technology**
Quality assurance of medical surfaces in production and laboratory
- **Material science**
Optimization of functional properties of new surfaces and products
- **Microsystems technology**
Measure complex surface geometries of smallest components with nanometer precision



For more information, please visit our website: www.mahr.com

MarSurf 3D surface metrology - industries

Automotive

- Powertrain
- Body-in-white
- Interior
- Electronics
- Glass components
- Coatings

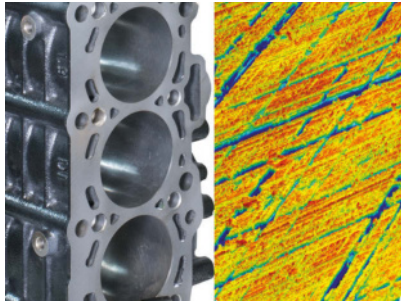

Medical technology

- Implants
- Microfluidics
- Sensors
- Stents
- Microtomes
- Smart materials

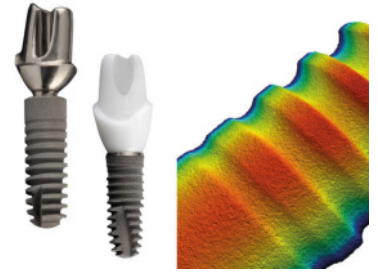

Energy

- Solar cells
- Fuel cells
- Batteries
- Gearbox and turbines

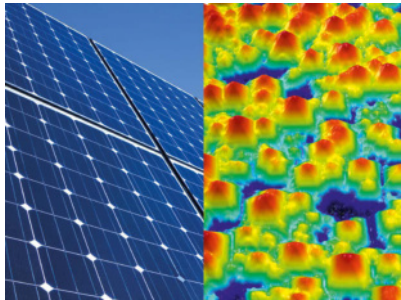

Microsystems

- MEMS
- LED
- High performance electronics
- BGA
- Micro-optics

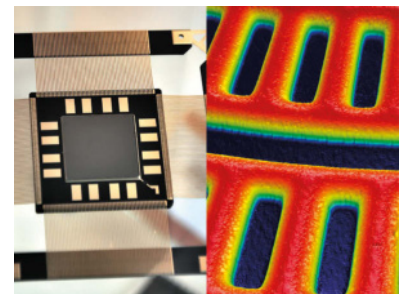

Printing and security

- Printing cylinder
- Printing plates
- Paper sieves
- Bank notes
- Security features
- Works of art
- Chip cards



Tools

- Cutting and milling tools
- Razor blades
- Sand paper
- Coatings
- Micro-tools



Electronic and semiconductor

- BGA
- MEMS
- High performance electronics
- Microelectronics
- Microvias
- Hybrid technology
- Conductor tracks and plates

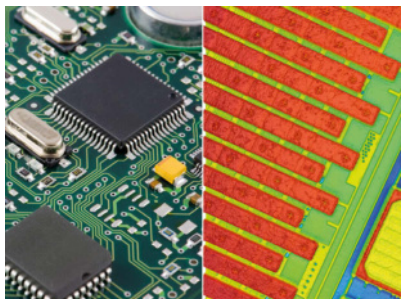

Optics

- Lenses
- Plane optics
- Freeform
- Aspheres
- Laser and x-ray mirrors

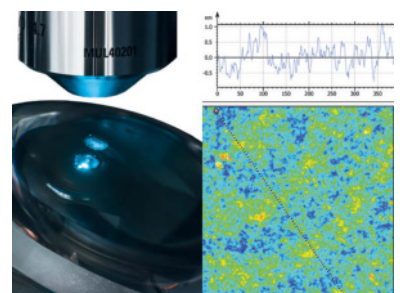

MarVision | Optical measuring instruments

Quality control is in a state of transition throughout the manufacturing industry: The pressure is on to measure workpieces more quickly, more accurately and yet at the same time, more cheaply. That is where measuring microscopes from Mahr come into their own. These instruments provide fast, contactless measurement of contours, distances, angles, radii as well as form and position features on your components, close to production. Even the smallest components can be measured very accurately by selecting appropriate zoom settings. Measuring microscopes from Mahr can be found in virtually every sector and deliver precision measuring results at an attractive price-performance ratio.

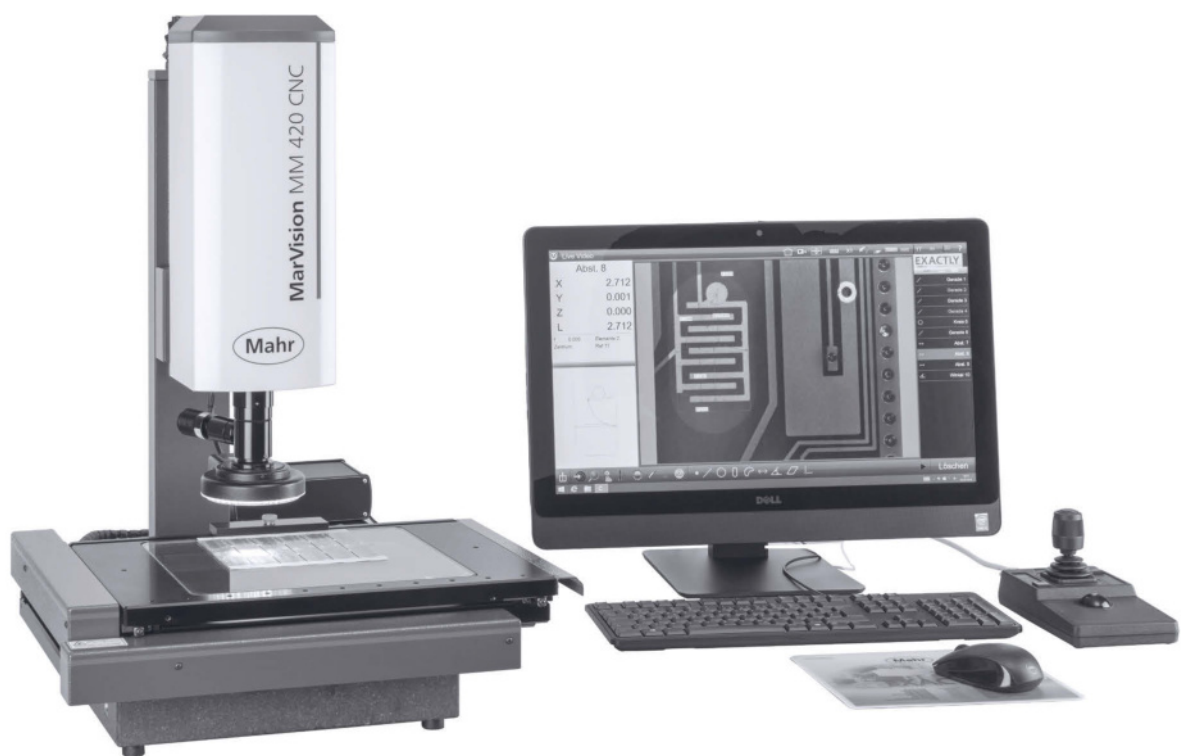

| | |
|---|------------|
| MarVision MM 420 | 572 |
| MarVision MM 420 CNC | 576 |
| Accessories for measuring microscopes | |
| MarVision 220 Set 2/1 / 220 Set 2/2 / 220 Set 2/3 Set of rack rails | 578 |
| MarVision 109 P / 109 Pst / 109 PS Miniature precision vises, set | 579 |

Workshop video

MM 420 measuring microscope

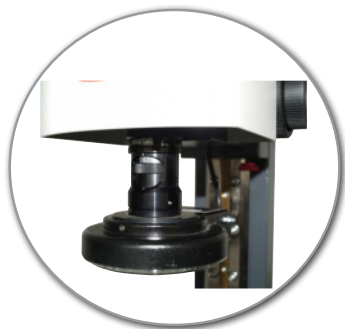

with 6-step
Navitar zoom lens

0.7-4.5x magnification

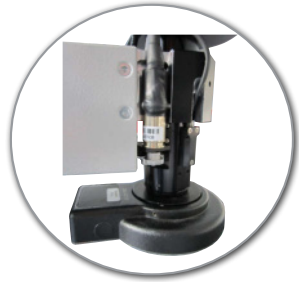

**Motorized
Navitar
zoom lens**

Stable Z-column

150 mm displacement path (can be optionally lengthened by 200 mm, also with measuring system)



Height adjustment

(fine/coarse; mounted on both sides) for sensitive focusing

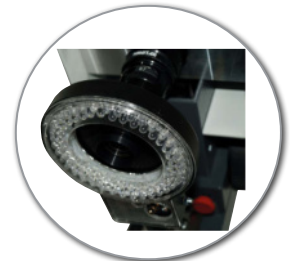

Quadrant LED ring light

(optional coaxial incident light for optimal illumination of plain surfaces)

LED transmitted light

(optional telecentric transmitted light for a sharp image of rotationally symmetrical parts)

Clamp



Quick adjustment

for covering large distances quickly

Solid granite

base

Fine adjustment

for exact positioning

MarVision MM 420 / MM 420 CNC

Configuration optics

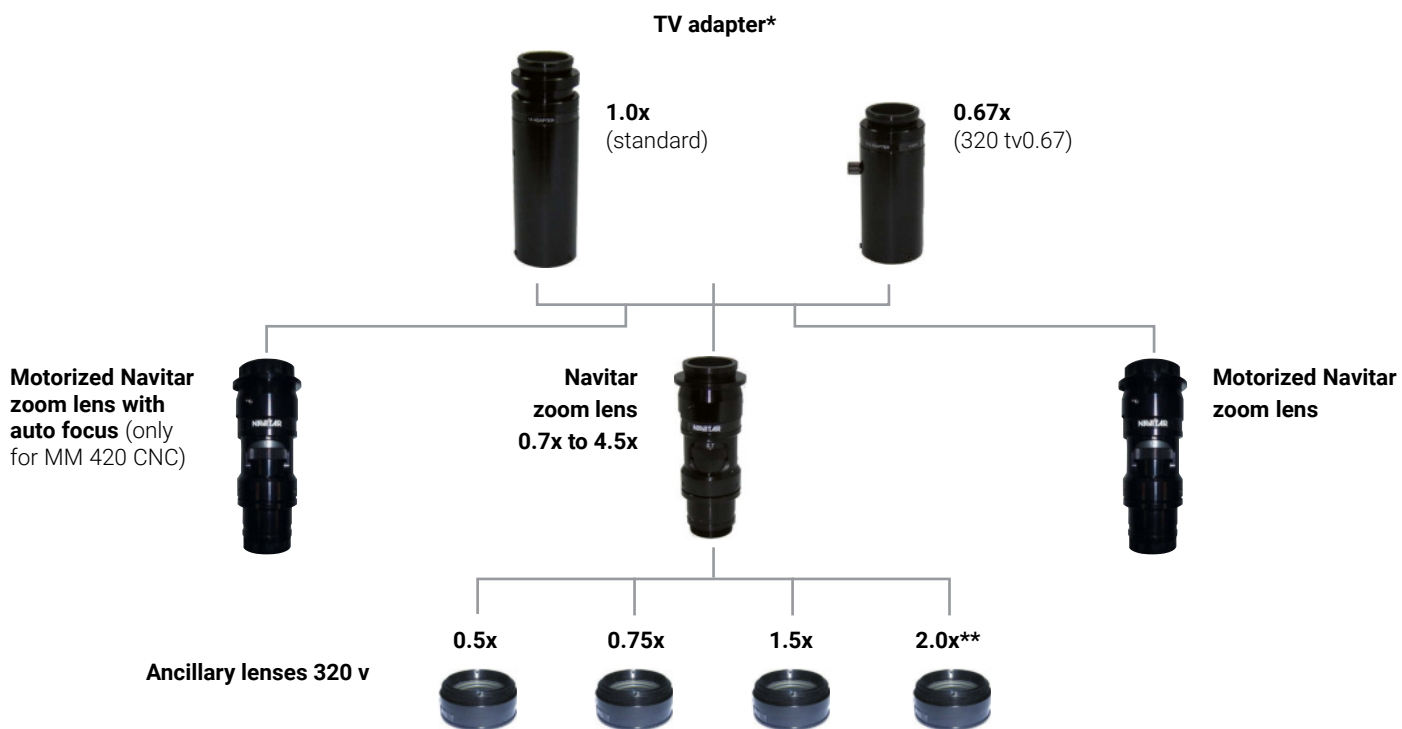

* please specify configuration when placing order

** ancillary lens 2.0x only upon request for MM 420 CNC instrument

TECHNICAL DATA ANCILLARY LENSES

| Order no. | | Magnification |
|-----------|-----------|---------------|
| 4247020 | 320 v0.5 | 0.5x |
| 4247021 | 320 v0.75 | 0.75x |
| 4247022 | 320 v1.5 | 1.5x |
| 4247023 | 320 v2.0 | 2.0x |

| Magnification / image sections | | Zoom magnification* | | | | | |
|--------------------------------|----------------|---------------------|-----------|-----------|-----------|-----------|-----------|
| TV adapter | Ancillary lens | 0.7x | 1.0x | 2.0x | 3.0x | 4.0x | 4.5x |
| | | 👁 / ○ | 👁 / ○ | 👁 / ○ | 👁 / ○ | 👁 / ○ | 👁 / ○ |
| 0.67 | — | 23 / 14.3 | 34 / 10.3 | 67 / 5.4 | 101 / 3.6 | 134 / 2.5 | 151 / 2.2 |
| 0.67 | 0.5 | 12 / 28.7 | 17 / 20.6 | 34 / 10.7 | 50 / 7.2 | 67 / 5.1 | 75 / 4.5 |
| 0.67 | 0.75 | 18 / 21.5 | 25 / 15.4 | 50 / 8.1 | 75 / 5.4 | 101 / 3.8 | 113 / 3.4 |
| 0.67 | 1.5 | 35 / 10.7 | 50 / 7.7 | 101 / 4.0 | 151 / 2.7 | 201 / 1.9 | 226 / 1.7 |
| 0.67 | 2.0 | 47 / 7.2 | 67 / 5.1 | 134 / 2.7 | 201 / 1.8 | 268 / 1.3 | 302 / 1.1 |
| 1.0 | — | 35 / 9.6 | 49 / 6.9 | 94 / 3.6 | 141 / 2.4 | 200 / 1.7 | 225 / 1.5 |
| 1.0 | 0.5 | 18 / 19.2 | 25 / 13.8 | 47 / 7.2 | 71 / 4.8 | 100 / 3.4 | 113 / 3.0 |
| 1.0 | 0.75 | 26 / 14.4 | 37 / 10.4 | 71 / 5.4 | 106 / 3.6 | 150 / 2.6 | 169 / 2.3 |
| 1.0 | 1.5 | 53 / 7.2 | 75 / 5.2 | 150 / 2.7 | 225 / 1.8 | 300 / 1.3 | 338 / 1.1 |
| 1.0 | 2.0 | 70 / 4.8 | 98 / 3.5 | 188 / 1.8 | 282 / 1.2 | 400 / 0.9 | 450 / 0.8 |

👁 Magnification on monitor

○ Image section in mm

* Circa values (mm x mm = mm²)

MarVision MM 420

Workshop measuring microscope with M3 software

FEATURES

- Integrated color camera
- Zoom lens (0.7x –4.5x), optionally motorized
- LED ring light: 1 ring and 4 segments, individually switchable and dimmable
- Dimmable LED transmitted light
- Laser pointer for position finding
- Solid granite base
- Sturdy steel XY table, precision-mounted
- Quick and fine adjustment of axes
- Optical incremental measuring system for outstanding accuracy and reliability

Control and display unit with M3 software and touchscreen PC

- 23" touchscreen with keyboard and mouse
- Windows 10 Pro operating system, additional software can be installed
- Operation via the multi-touch screen or with a mouse/keyboard
- Large video screen
- Reference/actual evaluation with tolerances
- Record output with company logo
- Graphical display with dimensioning
- Automatic edge detection, even on low contrast parts
- Stitching
- Statistics

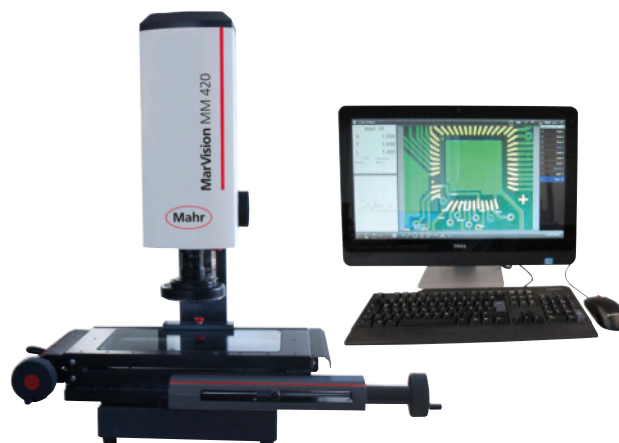

Application:

- Measurement or determination of geometric elements (point, straight line, circle, distance, intersection point, etc.) by automatic edge detection, e.g. on punched and bent components, plastic components, and circuit boards

TECHNICAL DATA

| Order no. | | 4247600 | 4247601 | 4247602 | 4247603 |
|--|---------------|---|-----------------|-----------------|------------------|
| Type | | MM 420 | | | |
| Measuring range X/Y | mm | 100 / 100 | 200 / 100 | 250 / 170 | 400 / 250 |
| Size of table | mm | 270 x 210 | 370 x 210 | 420 x 280 | 600 x 480 |
| Maximum table load | kg | 20 | | | |
| Measuring system | | Built-in incremental scale | | | |
| Measuring system - resolution | mm | 0,001 | | | |
| Measuring system - E1 X/Y in μm | μm | 1.9 + (L/100) | | 1.9 + (L/100) | 3.9 + (L/100) |
| Measuring system - E2 XY in μm | μm | 2.9 + (L/100) | | | 4.9 + (L/100) |
| Magnification | | 35 –225x | | | |
| Max. height of test piece | mm | | 115 | | 290 |
| Max. height of test piece / 0.5-fold | mm | | 20 | | 200 |
| Max. height of test piece with coax. | mm | | 115 | | 260 |
| 200 extension in Z | mm | | 315 | | |
| 200 extension in Z / 0.5-fold | mm | | 220 | | |
| Illumination | | LED back and front illumination, adjustable | | | |
| Energy supply: | | 230 V / 50 Hz | | | |
| H x W x D | mm | 700 x 480 x 430 | 700 x 650 x 550 | 700 x 700 x 600 | 800 x 1000 x 900 |

MarVision MM 420

Workshop measuring microscope with M3 software

ACCESSORIES

| Order no. | Description | Type |
|-----------|--|------------|
| 4246114 | Optional DXF file integration for M3 software | |
| 4247027 | Optional TV adapter, 0.67x (instead of 1.0x) | 320 tv0,67 |
| 4247028 | Optional Navitar zoom 6.5:1, motorized | 320 zmo |
| 4247029 | Optional Navitar zoom 6.5:1, motorized with coaxial light | 320 zmk |
| 4247035 | Optional Navitar 4 K motor-zoom 8x – 116x | |
| 4247050 | Optional telecentric transmitted light for measuring rotationally symmetrical parts | 200 ld |
| 4247039 | Optional telecentric transmitted light for Navitar 4 K motor zoom | 200 ldm |
| 4245300 | Optional coaxial LED incident light for zoom lens | 320 kaz |
| 4246050 | Optional Z axis with measuring system | 320 zm |
| 4246051 | Optional Z axis, extended by 200 mm | 320 Zv |
| 4246052 | Optional Z axis, extended by 200 mm, including measuring system | 320 zvm |
| 4247020 | Ancillary lens 0.5x (for Navitar objective lens only) | 320 v0.5 |
| 4247021 | Ancillary lens 0.75x (for Navitar objective lens only) | 320 v0.75 |
| 4247022 | Ancillary lens 1.5x (for Navitar objective lens only) | 320 v1.5 |
| 4247023 | Ancillary lens 2.0x (for Navitar objective lens only) | 320 v2 |
| 4246801 | Prisms, pair, for diameter 5–55 mm (measuring tables 100x100 mm, 200x100 mm) | 220 p |
| 4246802 | Center support, pair, center height 40 mm (measuring tables 100x100 mm, 200x100 mm) | 220 sp |
| 4246806 | Center support, pivoting, Ppair, center height 50 mm, distance between centers 130 mm (measuring table 200 x 100 mm) | 220 sps |
| 4246920 | Pivoting glass plate, Ø 100 mm (measuring table 200 x 100 mm) | 200 dk |
| 4246821 | 90° stop for MM 220 / MM 320 | 220 as90 |
| 4246901 | Calibration standard for circles, with calibration certificate for measuring microscope | 320 nkz |
| 4246071 | Protective cover for measuring tables 100x100 and 200x100 mm | |
| 4246115 | Upgrade M3-Software Version V1 to V2 | |
| 4246121 | Upgrade M3 software from version V2 to V3 | |
| 4246116 | DXF option and profiling package for MM 420 | |
| 4246117 | Upgrade from DXF to profiling for MM 420 / MM 420-CNC | |
| 4246118 | Thread measuring option for MM420 | |
| 4246119 | Optional cable insulation measurement for MM 420 | |
| 4246831 | Prisms, Pair, for diameter 5–55 mm (measuring table 250 x 170 mm) | 220 p |
| 4246833 | Center support, pair, center height 40 mm (measuring table 250 x 170 mm) | 220 sp |
| 4246807 | Center support, pivoting, Pair, center height 50 mm, distance between centers 130 mm (measuring table 250 x 170 mm) | 220 sps |
| 4246921 | Pivoting glass plate, Ø 100 mm (measuring table 250 x 170 mm) | 200 dg |
| 4246072 | Protective cover for measuring table 250x170 mm | |
| 4246054 | Option measuring system for extended Z-axis (350 mm) | 320 zvl |
| 4246832 | Prisms, Pair, for diameter 5–55 mm (measuring table 400 x 250 mm) | 220 p |
| 4246834 | Center support, Pair, center height 40 mm (measuring table 400 x 250 mm) | 220 sp |
| 4246808 | Center support, pivoting, Pair, center height 50 mm, distance between centers 130 mm (measuring table 400 x 250 mm) | 220 sps |
| 4246922 | Pivoting glass plate, Ø 100 mm (measuring table 400 x 250 mm) | 200 db |
| 4246825 | 90° stop for table 400x250 mm | 220 as90–1 |
| 4246073 | Protective cover for measuring table 400x250 mm | |

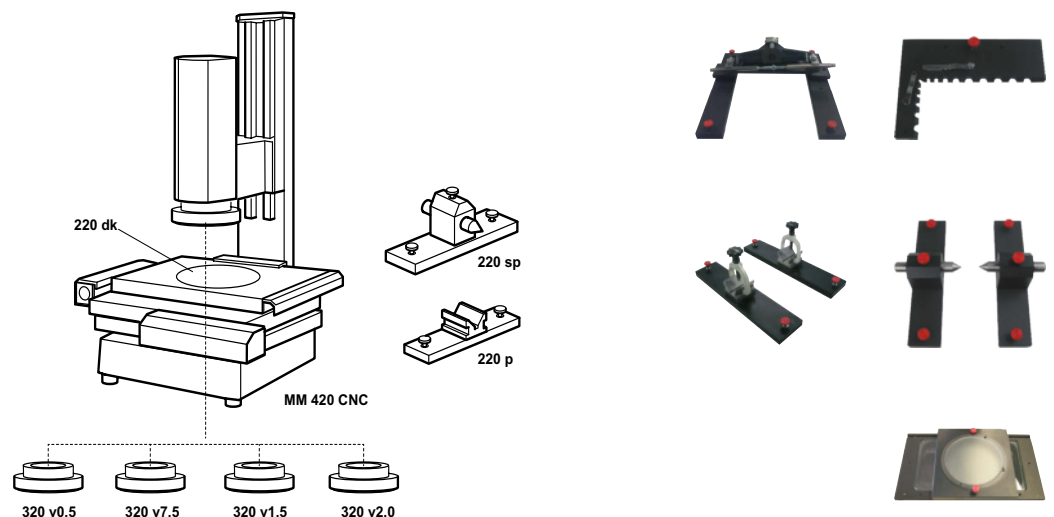

MarVision MM 420 CNC

CNC workshop measuring microscope

FEATURES

- 3-axes CNC control
- Axis movement and speed regulation controlled via the joystick
- Integrated color camera
- Motorized zoom lens (0.7x –4.5x) with autofocus
- LED ring light: 1 ring and 4 segments, individually switchable and dimmable
- LED transmitted light: dimmable
- Laser pointer for position finding
- Solid granite base
- Sturdy steel XY table, precision-mounted
- Optical incremental measuring system for outstanding accuracy and reliability

Operating and display unit M3 software with touchscreen PC

- 23" touchscreen with keyboard and mouse
- The operating system is Windows 10 Pro, so further software can be installed
- Operation via the Multi-Touch screen or with a mouse/keyboard
- M3 Software version 3
- Large video image
- Reference/actual evaluation with tolerances
- Record output with company logo
- Graphic display with dimensioning
- Automatic edge detection, even on low-contrast parts
- Stitching
- Statistics
- Palletizing of serial parts
- Optional hardware components
- Telecentric transmitted light
- Coaxial incident light
- Use of ancillary lenses 0.5x / 2x (additional magnification levels)
- Tactile measuring system Renishaw TP20
- Macro zoom Navitar 4 K motor zoom 8x–116x with 5MB camera
- 0.67x TV adapter for larger line of view

Software options

- Importing DXF data
- DXF and profiling package
- Thread measurement module
- Cable insulation module
- Upgrade of M3 versions V1 and V2
- QDAS converter program

Package contains:

M3 software with touchscreen PC, standard stop bar 220 as, instruction manual, Mahr calibration certificate



Application:

- Measurement or determination of geometric elements (point, straight line, circle, distance, intersection point, etc.) by automatic edge detection, e.g. on punched and bent components, plastic components, and circuit boards

TECHNICAL DATA

| Order no. | | 4247701 | 4247702 | 4247703 |
|---|---------------|---|---------------|-----------------|
| Type | | MM 420 CNC | | |
| Measuring range X/Y | mm | 200 / 100 | 250 / 170 | 400 / 250 |
| Size of table | mm | 370 x 210 | 420 x 280 | 600 x 480 x 200 |
| Maximum table load | kg | 20 | | |
| Measuring system | | built-in incremental scale | | |
| Measuring system - resolution | mm | 0,001 | | |
| Measuring system - E1 X/Y in μm | μm | 1.9 + (L/100) | 1.9 + (L/100) | 3.9 + (L/100) |
| Measuring system - E2 XY in μm | μm | 2.9 + (L/100) | | 4.9 + (L/100) |
| Magnification | | 35 –225x | | |
| Max. height of test piece | mm | 200 | | |
| Max. height of test piece / 0.5-fold | mm | 110 | | |
| Max. height of test piece with coax. | mm | 200 | | |
| Max. height of test piece with coax. / 0.5-fold | mm | 110 | | |
| Illumination | | LED back and front illumination, adjustable | | |
| Energy supply | | 230 V / 50 Hz | | |

MarVision MM 420 CNC

CNC workshop measuring microscope

ACCESSORIES

| Order no. | Description | Type |
|-----------|---|------------|
| 4247036 | Optional Navitar 4 K motor zoom 8x –116x for CNC-versions | |
| 4246114 | Optional DXF file integration for M3 software | |
| 4247027 | Optional TV adapter, 0.67x (instead of 1.0x) | 320 tv0,67 |
| 4247050 | Optional telecentric transmitted light for measuring rotationally symmetrical parts | 200 ld |
| 4247039 | Optional telecentric transmitted light for Navitar 4 K motor zoom | 200 ldm |
| 4245302 | Optional coaxial LED incident light for zoom lens | 320 kac |
| 4247020 | Ancillary lens 0.5x (for Navitar objective lens only) | 320 v0.5 |
| 4247021 | Ancillary lens 0.75x (for Navitar objective lens only) | 320 v0.75 |
| 4247022 | Ancillary lens 1.5x (for Navitar objective lens only) | 320 v1.5 |
| 4247023 | Ancillary lens 2.0x (for Navitar objective lens only) | 320 v2 |
| 4246801 | Prisms, Pair, for diameter 5–55 mm (measuring tables 100x100 mm, 200x100 mm) | 220 p |
| 4246802 | Center support, Pair, center height 40 mm (measuring tables 100x100 mm, 200x100 mm) | 220 sp |
| 4246806 | Center support, pivoting, Pair, center height 50 mm, distance between centers 130 mm (measuring table 200 x 100 mm) | 220 sps |
| 4246920 | Pivoting glass plate, Ø 100 mm (measuring table 200 x 100 mm) | 200 dk |
| 4246821 | 90° stop for MM 220 / MM 320 | 220 as90 |
| 4246901 | Calibration standard for circles, with calibration certificate for measuring microscope | 320 nkz |
| 4246071 | Protective cover for measuring tables 100x100 and 200x100 mm | |
| 4246834 | Center support, Pair, center height 40 mm (measuring table 400 x 250 mm) | 220 sp |
| 4246115 | Upgrade M3 software version V1 to V2 | |
| 4246121 | Upgrade M3 software from version V2 to V3 | |
| 4246116 | DXF option and profiling package for MM420 | |
| 4246117 | Upgrade from DXF to profiling for MM 420 / MM 420-CNC | |
| 4246118 | Thread measuring option for MM 420 | |
| 4246119 | Optional cable insulation measurement for MM420 | |
| 4247040 | Optional 3D tactile measuring system TP20, probe L=20 mm with ball diameter 2 mm | |
| 4247041 | Calibration standard ball Ø 20 mm and setting ring Ø 10 mm | |
| 4246831 | Prisms, pair, for diameter 5–55 mm (measuring table 250 x 170 mm) | 220 p |
| 4246833 | Center support, pair, center height 40 mm (measuring table 250 x 170 mm) | 220 sp |
| 4246807 | Center support, pivoting, pair, center height 50 mm, distance between centers 130 mm (measuring table 250 x 170 mm) | 220 sps |
| 4246921 | Pivoting glass plate, Ø 100 mm (measuring table 250 x 170 mm) | 200 dg |
| 4246072 | Protective cover for measuring table 250x170 mm | |
| 4246825 | 90° stop for table 400x250 mm | 220 as90–1 |
| 4246922 | Pivoting glass plate, Ø 100 mm (measuring table 400 x 250 mm) | 200 db |
| 4246832 | Prisms, pair, for diameter 5–55 mm (measuring table 400 x 250 mm) | 220 p |
| 4246808 | Center support, pivoting, pair, center height 50 mm, distance between centers 130 mm (measuring table 400 x 250 mm) | 220 sps |
| 4246073 | Protective cover for measuring table 400x250 mm | |

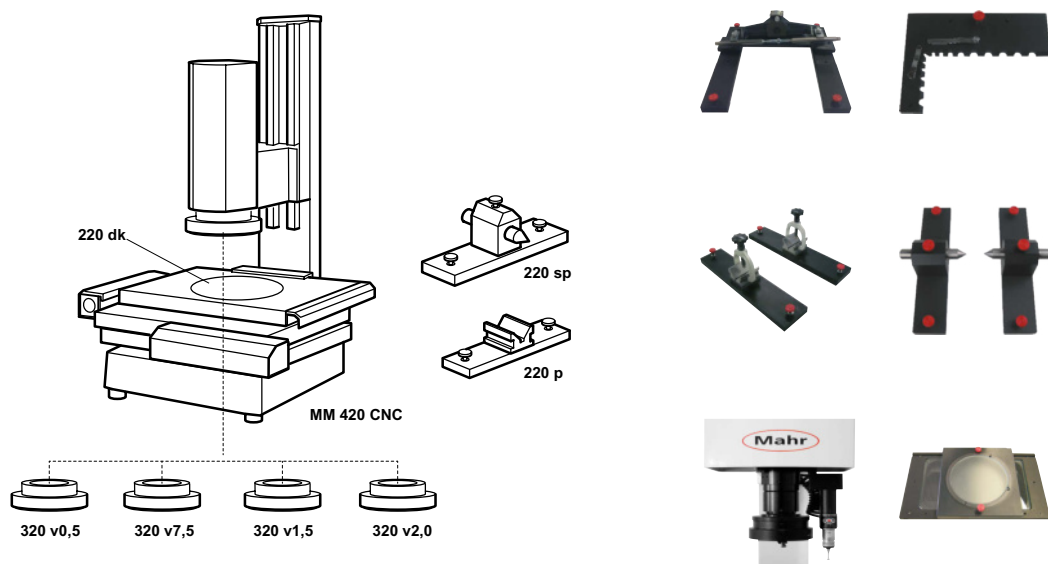

MarVision 220 Set 2/1 / 220 Set 2/2 / 220 Set 2/3

Set of rack rails for measuring range 200 x 100 mm

FEATURES

- Clamping elements

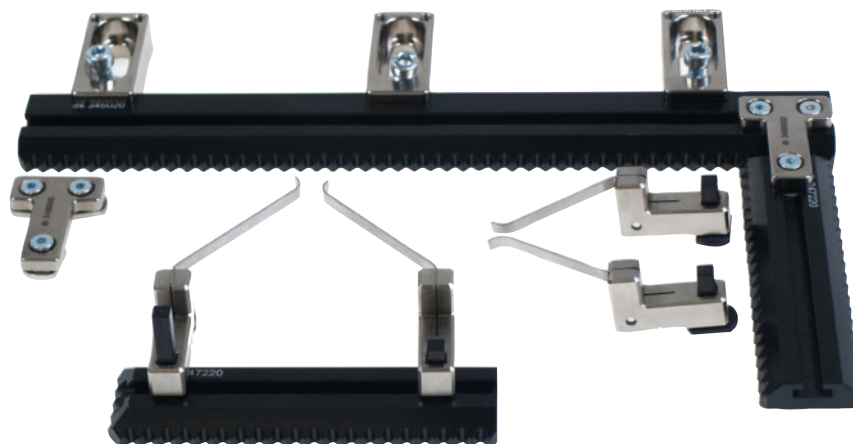

Application:

- For clamping workpieces on measuring microscopes

TECHNICAL DATA

| Order no. | Type | Set contents |
|-----------|-------------|---|
| 4246851 | 220 Set 2/1 | Rack rails for measuring range 200 x 100 mm |
| 4246852 | 220 Set 2/2 | Rack rails for measuring range 250 x 170 mm |
| 4246853 | 220 Set 2/3 | Rack rails for measuring range 400 x 200 mm |

ACCESSORIES

| Order no. | Description | Type |
|-----------|--|-----------|
| 4246850 | Set of clamping elements in wooden case | 220 Set 1 |
| 4246854 | V-supports, jaw chuck and tailstock | 220 Set 3 |
| 4246855 | Rotating swivel holder without jaw chuck rack rails | 220 ds |
| 4246856 | Precision jaw chuck for 0–3 mm for rotating swivel holder 220 ds | 220 pb03 |
| 4246857 | Precision jaw chuck for Ø 0–6.5 mm for rotating swivel holder 220 ds | 220 pb065 |

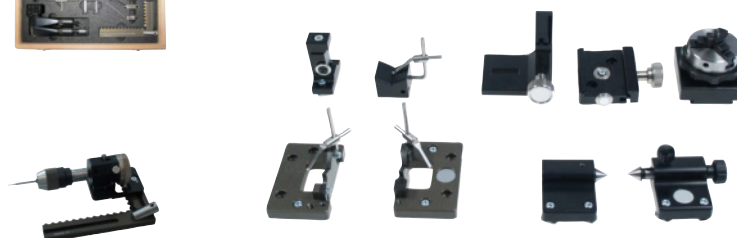

MarVision 109 P / 109 Pst / 109 PS

Vise with 15 mm jaw width

FEATURES

- Hard chrome plated or anodized construction (jaw width 15 mm)
- Exchangeable clamping jaws in hardened stainless steel and plastic



Application:

- For clamping small workpieces on measuring microscopes

TECHNICAL DATA

| Order no. | Type | Set contents |
|-----------|---------|---|
| 4246810 | 109 P | Mini vise, jaw width 15 mm |
| 4246811 | 109 P | Mini vise, jaw width 25 mm |
| 4246812 | 109 P | Mini vise, jaw width 35 mm |
| 4246813 | 109 Pst | Tripod for vise, jaw width 15 mm |
| 4246814 | 109 Pst | Tripod for vise, jaw width 25 mm |
| 4246815 | 109 Pst | Tripod for vise, jaw width 35 mm |
| 4246816 | 109 PS | Mini vises, jaw width 15 and 25 mm |
| 4246817 | 109 PS | Mini vises, jaw width 25 and 35 mm |
| 4246818 | 109 PS | Mini-vises, jaw widths 15 / 25 / 35 mm, with tripod and V-blocks |
| 4246819 | 109 PS | Mini-vises, jaw widths 15 / 25 / 35 mm, with tripod and V-blocks and miniature dividing attachments |

MarOpto | Measuring instruments for the optical industry

The role of metrology is changing, to keep pace with innovations in manufacturing processes. Given the continual stringent accuracy requirements and falling cycle times, rapid measurement directly at the manufacturing machine is absolutely essential. With MarOpto you can measure lenses, aspheres and freeforms at the point of origin of the product – with rapid feedback to the manufacturing process to avoid waste.



| | |
|---|------------|
| Metrology in lens production The close-to-production 3D measuring station | 582 |
| MarOpto MFU 200-3D Precision 3D measuring station | 584 |
| MarSurf LD 260 aspheric 2D and 3D Aspheric measuring station | 590 |
| MarSurf UD 130 aspheric 2D Aspheric measuring station | 591 |
| MarOpto FI 1040 Z Fizeau interferometer | 592 |
| MarOpto FI 1100 Z Fizeau interferometer | 593 |
| MarOpto MT 100 Measuring towers | 593 |



The latest information about MarOpto products can be found on our website:
www.mahr.com

MFU 200-3D – The close-to-production 3D measuring station – ultraprecise and universal

The MarOpto MFU 200-3D is a universal machine for measuring contour, roughness, axis offset, radial runout and tilt errors in lenses in one setup. It is ideal for spheres, aspheres, cylinder lenses and freeforms. Measurements are taken automatically, quickly and close to production in 2D and 3D. Due to the unique combination of optical and tactile probe arms, a reference surface of the component can be used to determine the form and position of the other surfaces. Mahr's tried and tested software platform MarWin provides the basis for various, modular evaluation options of the lenses. There is a new software package - AnyShape - available for this.

Users benefit from the following advantages:

- Increased productivity thanks to minimal calibration due to greater temperature stability
- Close-to-production option available thanks to measuring cabinet with attenuation
- Accuracy due to dynamic realtime compensation (measurement uncertainty < 100 nm [PV])
- Reference system on the component itself thanks to combination of optical and tactile sensors
- Flexibility thanks to measurable gradient angle of up to 45°
- Standard evaluation as per ISO 10110-5
- Universal thanks to automation of different measuring tasks on one machine

Shorter measuring times

The new quick-clamping device allows individual adjustment to the measuring object.

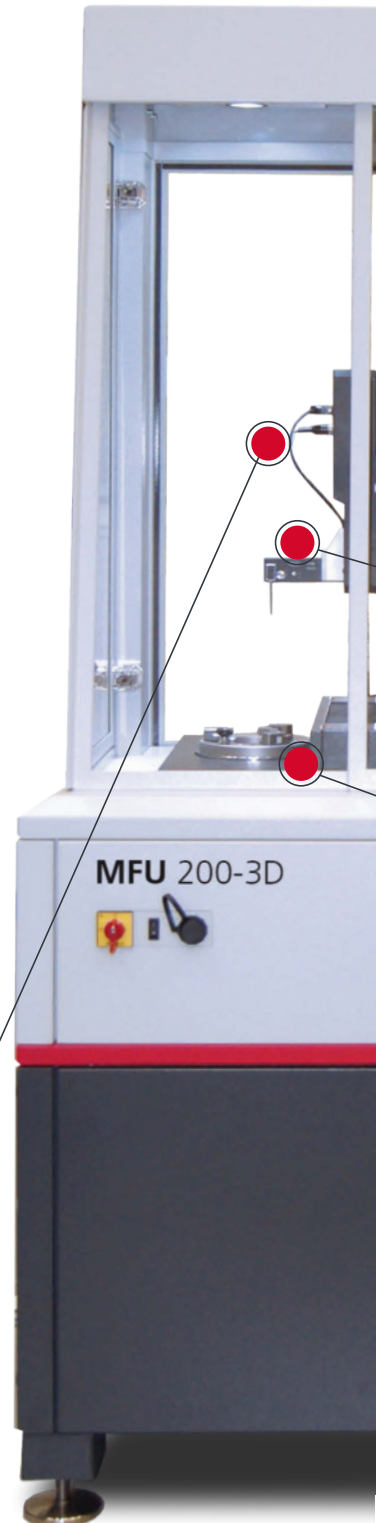

Maximum diameter

180 mm

X-axis

Noise figure

< 5 nm

Roundness deviation

< 20 nm

Measurement uncertainty

< 100 nm PV

Measurable gradient up to

45°

on rotationally symmetrical parts



Most reliable repeatability

Even better drives guarantee maximum reproducibility in the positioning range.

Flexible multisensor system

The flexible motorized probe measures alternately with the tactile probe arm or the optical sensor.

Automated measuring routine

The motorized centering and tilting means that user intervention is no longer required, ensuring process stability.

Unique precision

The MarOpto MFU 200-3D is the most accurate polar coordinate measuring machine in the nm range for lens components.

MarOpto MFU 200-3D

High-precision 3D measuring station for spheres, aspheres and freeforms

DESCRIPTION

The MFU 200-3D is a universal, highly accurate measuring machine for the automatic measurement of spheres, aspheres, freeforms, and special lenses and was developed by Mahr to enable optical components to be tested quickly in 2D and 3D close to the production area.

Accuracy

- With a measurement uncertainty of less than 100 nm PV, the measuring instrument is perfectly designed to meet your process optimization requirements.

Flexibility

- The MFU 200-3D can perform optical and tactile measurements of surfaces. An interferometric point sensor is used for the optical measurement. There is a wide range of probe arms for tactile measurements. Rotationally symmetrical objects with a kurtosis of up to 45°, off-axis and freeforms up to 28° can be measured.



TECHNICAL DATA

| Order no. | 5440581 |
|--------------------------------------|--|
| Type | MFU 200-3D |
| Monitor | 19" TFT monitor (touchscreen monitor) |
| Control panel | MCP 12 |
| Motorized measuring probe | T7W |
| Optical measuring probe | IPS |
| Probe arm | 90° angled, ruby ball ø 3mm, incl. connection for optical sensor |
| Pitch error | Pitch error of the C-/Z-/X-axis is calibrated |
| Calibration set and Basic clamp set | included |
| MFU 200-3D Aspheric software package | included |
| MFU 200-3D Anyshape software option | optional |

ACCESSORIES

| Order no. | Description |
|-----------|--|
| 5440468 | Hydraulic expansion chuck ø 25 mm for quick clamp system |
| 5440471 | Three-jaw chuck for quick clamp system |
| 5440472 | Vise for quick clamp system |
| 5440473 | Index plate for quick clamp system |
| 5440474 | Mounting plate |
| 3028108 | Adapter for hydraulic expansion chuck 25 mm – 12 mm |
| 9058047 | Clamps for 200 mm lenses |

Clamp set

Universal design for every purpose – the design ensures you are well equipped even if you have a broad range of components.

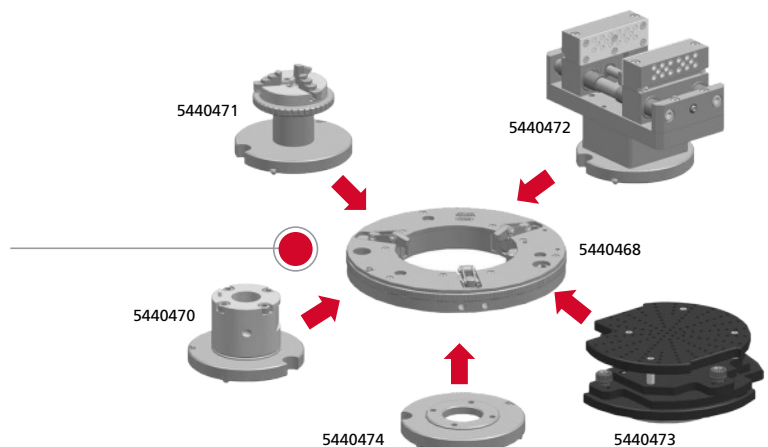

MarOpto MFU 200-3D

High-precision 3D measuring station for spheres, aspheres and freeforms

ADVANTAGES

- Automatic tilting and centering – user-independent positioning, centering, and alignment of measuring objects
- Active tracking – automatic measurement of unknown geometries; the sensor (optical and tactile) automatically follows the surface via the machine controller
- Probe combination – combination of optical sensors and tactile probes can be combined in one probe system; can be moved in space (360°)
- Closed loop integration in the production process (grinding/polishing) perfect for transmissive optics (tilt/centering error designation)

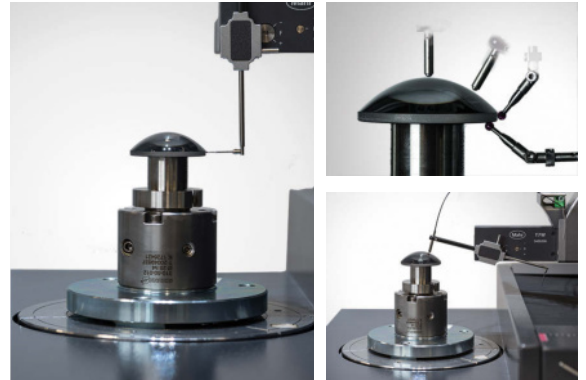

MEASURING TASKS & SOFTWARE

Flexible measuring tasks in one machine

- Form
- Contour
- Roughness
- Axis offset of lenses
- Radial runout error
- Tilt and centering error of the optics

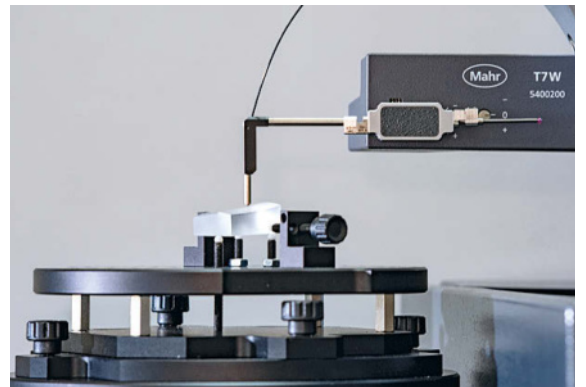

SOFTWARE

Special software package for your requirements

- AsphericLib software for measuring and evaluating spheres and aspheres
- SW analysis of the tool for the future – freeform measurement and evaluation

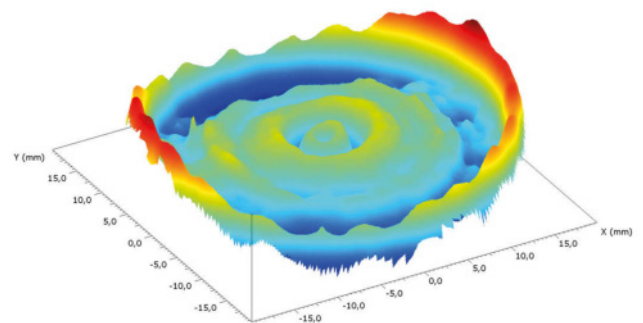

For more information, please visit our website: www.mahr.com

Contour and surface measuring station for production

MarSurf LD 260 Aspheric 2D / 3D

The MarSurf LD 260 Aspheric measuring station is a highly precise 2D / 3D surface measuring station for measuring contours on spheres, aspheres and optical components. Check and correct your individual production steps in closed loop operation. Mahr's tried and tested software platform MarWin provides the basis for flexible evaluation using Aspheric Lib.

Users benefit from the following advantages:

- Closed loop – Output the differential profile to correct the machine tool
- Check the surface in the first machining operations
- Operating concept for production control
- Electronic control of contacting force for different applications

Bionic-style LP D probe arm

Improved dynamics and optimized design, change probe arm without calibration

Measurement of diffractive structures

Determines the form deviation, zone height and distances and much more

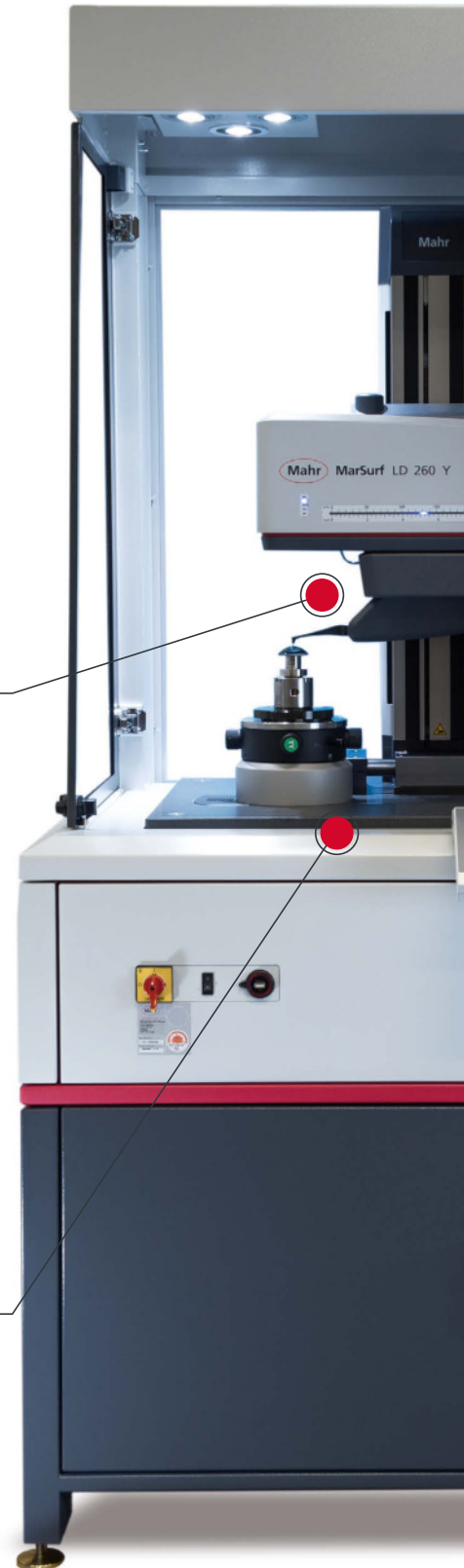

Max. measuring range

260 mm

X-axis

Vertical resolution

0.8 nm

Max. measuring speed

10 mm/s

Form deviation 2D

≤ 100 nm

Form deviation 3D

≤ 200 nm

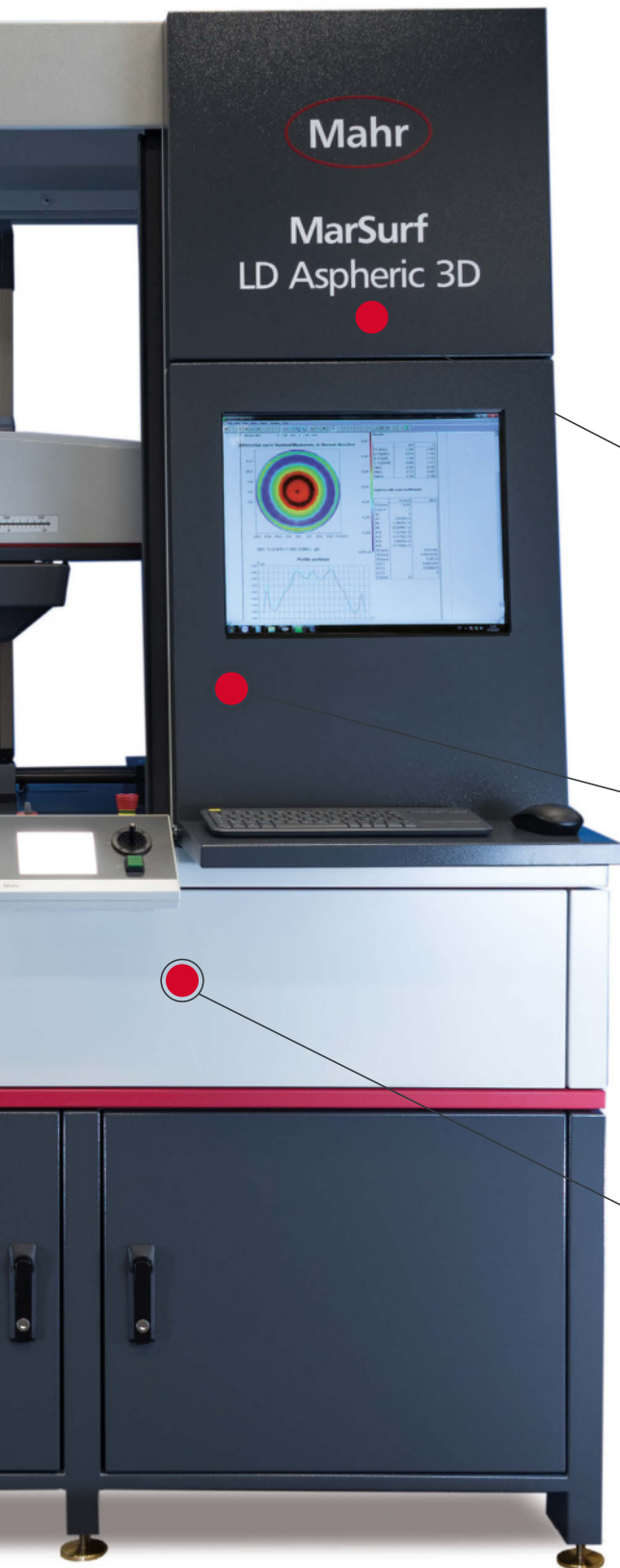

DIN ISO 10110

Evaluation as per DIN ISO 10110-5

Increased flexibility



Different types of rotationally symmetrical aspheres can be measured with one measuring system.

Measurement of bi-aspheres

Optical lenses can be measured on both sides in absolute reference to one another.

Powerful software for measuring tasks in lens production

Mahr not only offers universal hardware with the MarOpto MFU 200-3D, but also the perfectly compatible measuring and evaluation software based on the MarWin platform for the special applications of the optical industry. The user interface of the software is clearly laid out and easy to navigate.

|  AnyShape  AsphericLib | | Geometry of lens surface | |
|---|--------------|----------------------------------|------------------------------------|
| | | rotationally symmetrical | non-rotationally symmetrical |
| Outer aperture of the lens (reference measurement) | circular | asphere, sphere, optical flat... | cylinder lens, toroid, off axis... |
| | non-circular | asphere, sphere, optical flat... | cylinder lens, toroid, off axis... |

AsphericLib

The AsphericLib software package measures spheres, aspheres and mounting surfaces and evaluates the results. Users can benefit from the following options:

- Automated 2D and 3D measurement
- Define nominal geometries using a clear software interface
- Analyze and display the surface form deviation and the slope error in a graph in accordance with ISO 10110-5
- Reverse engineering and simulation: Determine the asphere coefficients of unknown geometries
- Export profiles for correcting machine tools in file formats
*.mod, *.txt, *.ascii, *.dat, *.xyz, *.zygo.dat, *.x3p
- Import geometry data from the machine tool
- Automatically create measuring records with ISO 10110-5 parameters

Sample applications for testing optical components

The software packages of the MarOpto MFU 200-3D enable the optimal testing of all the relevant optical components with regard to their relevant properties. The following measuring sequences are possible, for example:



Measuring aspheres with AsphericLib

The following measuring routine is specified for testing aspheres with AsphericLib:

- Enter the target parameters (R, k, Ai)
- Automatic alignment of testpiece
- Measure the topography using circular paths
- Evaluate as 3D differential topography and 2D difference profile
- Evaluation as per ISO 10110-5
- Information about power, irregularity, RMSi, R0 etc.

Measuring freeforms with AnyShape

The following measuring routine is specified for testing freeforms with AnyShape :

- Enter geometric parameters (Torus, Biconic, cylinder, off axis, free analytical description)
- Define mechanical fiducials
- Calibrate the workpiece position using fiducials
- Measure the topography using circular paths
- Evaluate as 3D differential topography (R, PV, RMS, Slope)
- Evaluate centering errors (optical axis against mechanical references)

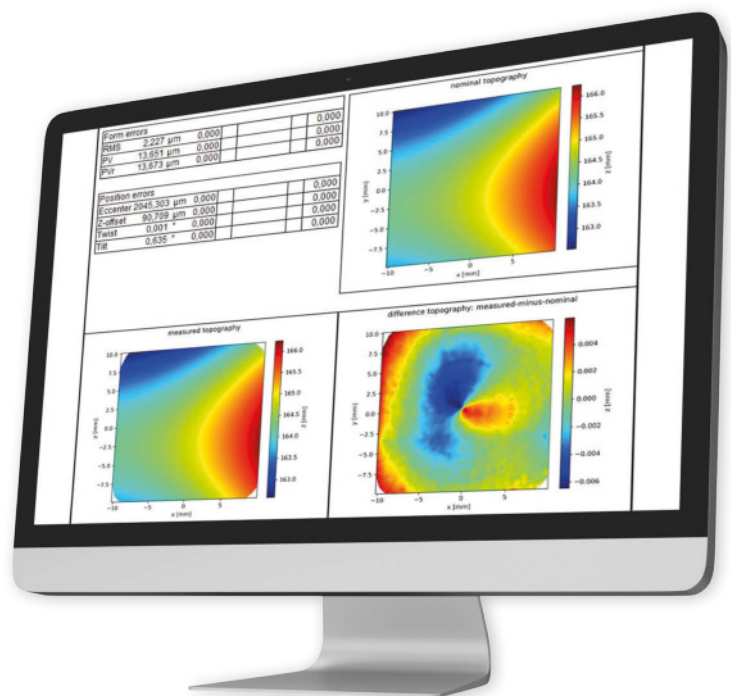

MarSurf LD 260 Aspheric 2D and 3D

Asphere measuring station

DESCRIPTION

MarSurf LD 260. The step into a new dimension

- MarSurf LD 260 Aspheric is a high-precision 2D / 3D surface measuring station for characterizing the contour and roughness of optical components. MarWin is the operating and evaluation software.

Checks the surface in the first machining operations

- Early detection of deviations, thus avoiding costly reworking
- Differential profile output in machine-readable format for controlling the machine tool (closed loop)

Increased flexibility

- Different types of rotationally symmetrical aspheres can be measured with one measuring system, no additional investment required
- Large measuring range up to 260 mm
- Maximum measuring speed and dynamics (up to 10 mm/s for large lenses / up to 0.02 mm/s for microlenses)
- Fully positionable stylus tip

Bionic-style LP D probe arm

- Improved probe system dynamics thanks to increased rigidity and attenuation as well as a lower moment of inertia:
 - Optimized overall design of the probe system
 - Innovative choice of materials
- Probe arm with integrated chip for:
 - Detecting and identifying the probe arm
 - Checking that the probe arm is inserted correctly
 - Providing information from probe arm

Your results will be right

- The high-precision MarSurf LD 260 is the basis for the accurate measurement of your workpieces. The vertical resolution of 0.8 nm and form deviations of < 100 nm guarantee the exact reproduction of your asphere.
- Probe arm change with no need to recalibrate
- Lenses with steep sides can be measured

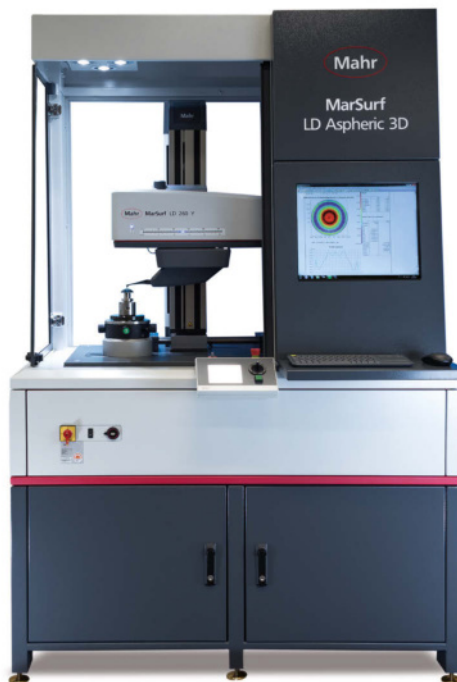

TECHNICAL DATA

| Type | MarSurf LD 260 2D-Aspheric | MarSurf LD 260 3D-Aspheric |
|---|---|-----------------------------------|
| Structure | Measuring cabin | |
| Operation | Control panel and 19" TFT monitor (touch screen) | |
| Measuring column | ST 500 CNC/HZ | ST 500 CNC/HZ/HB |
| Probe arm | LP D 14-10-2/60 LP D 14-10-500 LP D 1100-10-500 | LP D 14-10-2/20 LP D 14-10-500 |
| Formal error | ≤ 100 nm | ≤ 200 nm |
| Resolution | 0.8 nm | 0.8 nm |
| Calibration set and clamping device set | incl. | incl. |
| MarOpto Aspheric software package | incl. | incl. |

MarSurf UD 130 Aspheric 2D

Asphere measuring station

DESCRIPTION

MarSurf UD 130. A step into a new dimension

- MarSurf UD 130 Aspheric is a high-precision 2D surface measuring station for characterizing contour and roughness on optical components. MarWin is the operating and evaluation software.

Checks the contour in the first machining operations

- Early detection of deviations, thus avoiding costly reworking.
- Differential profile output in machine-readable format for controlling the machine tool.

Increased flexibility

- Different types of rotationally symmetrical aspheres can be measured with one measuring system. No additional investment required.
- Measuring range up to 130 mm
- High measuring speed and dynamics (up to 5 mm/s for large lenses / up to 0.1 mm/s for microlenses)
- Fully positionable stylus tip.

Innovative LP D probe arm

- Improved probe system dynamics by increased rigidity and attenuation as well as a lower moment of inertia:
 - optimized overall design of the probe system
 - innovative choice of materials
- Probe arm with integrated chip for:
 - detecting and identifying the probe arm,
 - checking that the probe arm is inserted correctly,
 - providing information from probe arm.

Your results will be right

- The high-precision MarSurf UD 130 is the basis for the accurate measurement of your workpieces. The vertical resolution of 2 nm and form deviations of < 300 nm guarantee the exact reproduction of your asphere.
- Probe arm change with no need to recalibrate.
- Lenses with steep sides can be measured.



TECHNICAL DATA

| | |
|---|---|
| Type | MarSurf UD 260 2D-Aspheric |
| Operation | Control panel and 24" TFT monitor (workstation) |
| Measuring column | ST 500 CNC/HZ |
| Probe arm | LP D 14-10-2/60 LP D 14-10-500 |
| Formal error | ≤ 300 nm |
| Resolution | 2 nm |
| Calibration set and clamping device set | incl. |
| MarOpto Aspheric software package | incl. |

MarOpto. Fizeau interferometer

Versatile and powerful in measuring rooms and production

Powerful MarOpto Fizeau interferometers can provide contactless measurements on flats and spherical surfaces and of transmitted wavefronts. MarOpto interferometers are ideal for measuring optical components such as flats, prisms and lenses or precision metal workpieces including bearings, sealing surfaces and polished ceramics.

Measurements can be performed by means of simple interference ring detection, IntelliPhase static spatial carrier analysis, or phase-modulated interferogram analysis. MarOpto Fizeau interferometers offer the flexibility and excellent performance that today's industrial applications demand.



MarOpto FI 1040 Z

Fizeau interferometer

DESCRIPTION

Powerful 40 mm Fizeau interferometer for flat and spherical surfaces

The MarOpto FI 1040 Z is a powerful interferometer that can provide contactless measurements on flats and spherical surfaces and of transmitted wavefronts. The MarOpto FI 1040 Z is ideal for measuring optical components such as flats, prisms and lenses or precision metal workpieces (bearings, sealing surfaces, and polished ceramics). Measurements can be performed by means of simple interference fringe detection, IntelliPhase static spatial carrier analysis, or phase-modulated interferogram analysis. The MarOpto FI 1040 Z offers the flexibility and excellent performance that today's industrial applications demand.

- 6x / 3x zoom for workpieces with a diameter of up to 1.5 mm
- 3 modes of interferogram analysis: Phase shifting, IntelliPhase – static spatial carrier analysis
- Small size allows easy integration into OEM systems
- Compact, rugged design
- Transmission spheres from F / 0.7 to F / 6.0

APPLICATIONS

- Transmission and surface testing of small optics
- Measurements on optics, machined parts, ceramics, semiconductors, and wafers
- Integrated radius of curvature measurements



For more information, please visit our website: www.mahr.com

MarOpto FI 1100 Z

Fizeau interferometer

DESCRIPTION

High accuracy measurement capability with unsurpassed flexibility and versatility

The MarOpto FI 1100 Z offers contactless measurements on flats and spherical lenses. In addition, wavefront measurements can be performed on optical components or assemblies in transmitted light. Measurements may be made by means of simple interference fringe analysis or phase-modulated interferogram analysis. The established IntelliWave software offers superior measurement and analysis capability. The MarOpto FI 1100 Z provides the versatility and reliability to handle today's advanced applications at unrivaled value for money.

- Total USB connectivity option (laptop or desktop) with 1k x 1k true spatial resolution
- Excellent versatility, stability and repeatability
- 1x to 6x zoom, focus and attenuation controls
- Vibration-insensitivity can be accomplished via Mahr's IntelliPhase™ Static Spatial Carrier Acquisition and Analysis Software
- Compact, lightweight and rugged design
- Compatible with all industry standard 4" (100 mm) reference optics and accessories
- High accuracy measurements at an affordable price
- Configurations include horizontal, vertical look up and vertical look down. Optional workstations for flats and for radius of curvature measurements



APPLICATIONS

- Measurement of flat, concave or convex surfaces
- Prism, corner cube, wedge angle and homogeneity measurements
- Measurement of machined, ceramic, and wafer surfaces
- Wavefront analysis of optical systems and components
- Integration into OEM systems

MarOpto MT 100

Measuring towers

DESCRIPTION

The MarOpto MT series provides various versions of modern workshop interferometer towers for use in the production environment. The vertical tower solutions offer simple lens handling, include vibration damping, and require minimal floor space. In addition to yoke testing, the towers with a scale ensure highly accurate radii measurements can be completed. Motorized axes help to complete tasks quickly and easily.

The **MarOpto MT 100** is a highly accurate Fizeau interferometer measuring tower used to test spherical and flat glass surfaces. The stable and vibration-resistant design make this 4" interferometer measuring tower the perfect tool for the production of high-performance lenses. It is also available as an inverse measuring tower – the **MarOpto MT 100i**.

- Highest precision in the production environment:
- Rigid granite tower with passive vibration isolation by four shock absorbers
- Measuring table with clearance-free bearings on linear slides
- Measuring table positioner via a servo motor and ball screw
- Fine selection of speed using joystick
- Manual fine adjustment of the measuring table with fine thread screw via backlash-free preloaded precision cross-roller guides
- 3-axes table: Z-axis in the basic unit and cross table for lenses up to 100 mm
- High-precision glass scale for the absolute measurement of radii, mounted close to the optical axis (Abbe comparator principle)

Options:

- The interferometer measuring tower MarOpto MT 100 can optionally be expanded with a lens extension, lens protection and lens holder.
- Remote control for focus and zoom
- Tilting table 120 mm



For more information, please visit our website: www.mahr.com

Mar4D | Cylinder coordinate measuring machines

The cylinder coordinate measuring machines from the Mar4D PLQ 4200 product range measure rotationally symmetrical workpieces with more flexibility and more conveniently than ever before. They also operate at the highest speed and level of precision providing fast and reliable measuring results.

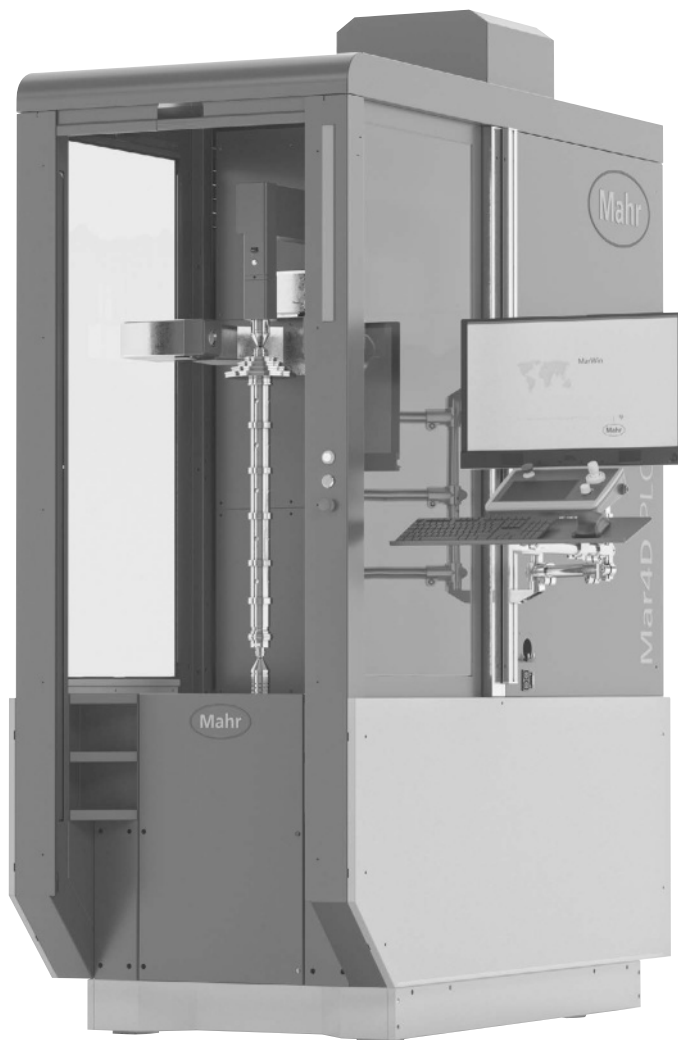

Overview Mar4D PLQ

Cylinder coordinate measuring machines

596

Mar4D PLQ 4200

Cylinder coordinate measuring machine

598

Mar4D PLQ 4200: Fast and precise measurement during production

The cylinder coordinate measuring machines from the Mar4D PLQ 4200 product line measure rotationally symmetrical workpieces with more flexibility and more conveniently than ever before. They operate at the highest speed and level of precision providing fast and reliable measuring results.

With the Mar4D PLQ 4200, Mahr provides its customers with a high-performance measurement solution for complex rotationally symmetrical workpieces. The multisensor system covers a particularly broad range of dimensional measuring tasks. The new machine also has a particularly sturdy design enabling 3D measurements to be completed directly during production, as well as offering shorter processing times and thus increased throughput and excellent productivity rates.



Advantages

- Future-proof due to combined measuring technology: optical and tactile solution in one machine
- Versatile: Measure several features such as the length, diameter, form, position, contour, roundness, roughness, or 3D geometries, such as the symmetry, during a single measuring run
- Fast and precise: Unique speed and optimum axis accuracy even as the tolerances become smaller, achieved thanks to specially developed control architecture
- Flexible for workpieces with a diameter up to 200 mm, a length of up to 1000 mm and a weight of up to 50 kg
- Ergonomic operation and unique safety concept

Fast alignment

The motorized tailstock with clamping force monitor secures the workpieces perfectly without operator intervention.

Process reliability when measuring

Monitoring systems in the machine record and compensate for external influences, such as temperature, vibrations and position in real-time.

Ergonomic design

The sophisticated design of the machine guarantees easy and safe operation.

Reliable software

Thanks to its clearly structured user interface, the MarWin platform software is very user friendly: learn once, apply again and again.

Universally applicable

The multisensor technology of the Mar4D PLQ 4200 enables measurement of various rotationally symmetrical workpieces directly in production.



Detailed information can be found on our website:
<https://metrology.mahr.com/en/mar4d-plq>

Mar4D PLQ 4200

Cylinder coordinate measuring machine

FEATURES

- Fast and precise measurement on the production line
- Simple operation
- Process reliability during measurement
- Ergonomic design
- Reliable software
- Universally applicable
- Telecentric precision optics



TECHNICAL DATA

| Order no. | | 5554200/5554250 | 5554201/5554251 | 5554202/5554252 |
|---|---------------|--|-------------------------|--------------------|
| Type | | PLQ 4200-T2 Z=450 | PLQ 4200-T2 Z=730 | PLQ 4200-T2 Z=1000 |
| Dimensions W/H/D | mm | 800 / 2200 / 1800 | 800 / 2500 / 1800 | 800 / 2500 / 1800 |
| Workpiece weight | kg | | max. 20 kg / max. 50 kg | |
| Workpiece dimension | mm | 450 | 730 | 1000 |
| Max. diameter | mm | 200 | | |
| Measured value resolution | | adjustable | | |
| Lengths/Diameters | mm | 0.01...0.0001 | | |
| Angle | | 0.01...0.0001 degrees (decimal) or degrees, minutes, seconds | | |
| Error limit diameter only, $E_{BXZ,MPE}^*$ | μm | $\leq (1 + L/150)$ L in mm | | |
| Error limit only length parallel Z, $E_{BXZ,MPE}^*$ | μm | $\leq (2 + L/200)$ L in mm | | |
| Traversing speed Z | | max. 200 mm/s | | |
| Traversing speed X1 | | max. 200 mm/s | | |
| Traversing speed X2 | | max. 50 mm/s | | |
| Traversing speed C | | max. 720°/s / 125°/s | | |
| Traversing speed Y | | max. 50 mm/s | | |

* Tempered workpiece at $t=20 \pm 2^\circ\text{C}$, on smooth surfaces ($R_z < 1 \mu\text{m}$) Din EN ISO 10360-7

Subject to technical changes

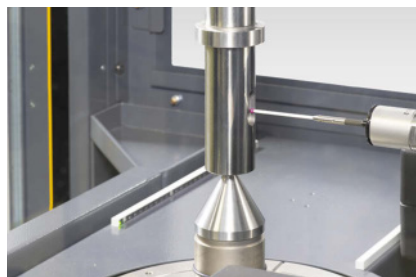

Tactile measurements with SP25

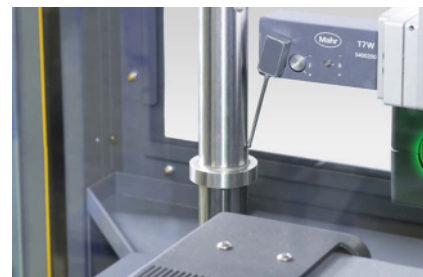

Tactile measurements with T7W

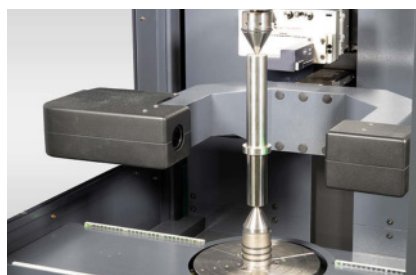

Optical measurements



Control panel

Mar4D PLQ 4200

Cylinder coordinate measuring machine

ACCESSORIES

| Order no. | Description | Type |
|-----------|--|-------|
| 5361112 | Center point 60°, Ø 2–5 mm, height 35 mm | |
| 5361223 | Center point 60°, Ø 2–44mm, height 46 mm | |
| 5361105 | Center point 60°, Ø 3–15 mm, height 25 mm | |
| 5361106 | Center point 60°, Ø 2–19 mm, height 44 mm | |
| 9056631 | Center point 60°, Ø 2–35 mm, height 46 mm | |
| 5361104 | Hollow point 90°, Ø 6–20 mm, height 56 mm | |
| 3026166 | USB keyboard German | |
| 3026167 | USB keyboard English | |
| 5550400 | Tactile probe motorized | T7W |
| 5400211 | Probe set | T7W |
| 5550250 | Tactile probe Renishaw | SP25M |
| 5550251 | Probe set 1 for SP25 | |
| 5550252 | Probe set 2 for SP25 | |
| 5550083 | MarControl manual control panel | |
| 5550085 | Second monitor plus holder | |
| 5550080 | Case plus package | |
| 5550084 | Industrial PC | |
| 5550086 | Panel PC, included in the scope of delivery | |
| 5550091 | Passive, controlled vibration isolation system | |
| 5550100 | MarWin complete package | Mar4D |
| 5550460 | Option roughness measurement T7W for PLQ 4200 | |
| 5480638 | Software option roughness for AdvancedForm | |
| 5360581 | 3-D contour standard (without calibration certificate) | |
| 9964316 | Mahr calibration certificate for contour standard | |
| 6980110 | DAkkS / DKD - calibration for contour standard | |



Center point 60°
Ø 2–15 mm



Center point 60°
Ø 2–44 mm



Center point 60°
Ø 3–15 mm



Center point 60°
Ø 2–19 mm



Center point 60°
Ø 2–35 mm

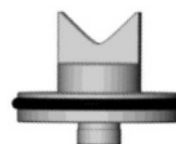

Hollow point 90°
Ø 6–20 mm

MarForm | Form measuring instruments

The error-free functioning and durability of a workpiece is determined not only by its dimensions but above all by its shape. Requirements are rising all the time, whether in terms of roundness, flatness, straightness, coaxiality or run-out - especially in the case of rotationally symmetrical workpieces. MarForm helps you to cut process costs, without driving up testing costs - by means of stable, innovative instruments offering a high degree of automation, flexibility and accuracy.



| | |
|--|------------|
| MarForm MMQ 100 Compact form measuring machine | 605 |
| MarForm MMQ 150 Compact form measuring machine | 606 |
| MarForm MMQ 200 Compact form measuring machine | 607 |
| MarForm MMQ 400 Universal form measuring machine | 608 |
| MarForm MMQ 500 Universal form measuring machine | 610 |
| MarForm MFU 200 Reference form measuring station | 611 |
| MarForm accessories | 612 |
| MarForm software MarWin | 617 |



The latest information about MarForm products
is available on our website: www.mahr.com

Precise measurement of form and position – MMQ 500

Based on the variety of precise measurement options, the MarForm MMQ 500 is the best when it comes to tabletop formtesters. The optimized design of the machine ensures that it can be implemented universally guaranteeing maximum utilization. The innovative design of the device makes it extremely easy and safe to operate. You can position all of the components perfectly for your measurement using just one hand. The measuring process itself boasts impressively high speeds. This is because the Z-axis allows movements of up to 100 millimeters/second, making it more than three times faster than conventional measuring machines. The integrated, high-performance MarWin software with its clearly structured user interface provides a user-friendly and secure working environment.

- Universally applicable: from small workpieces that are a few millimeters in size through to heavy components with a weight of up to 80 kg
- Recording the form, position, roughness, contour, and lead in one measuring sequence
- Accurate alignment of workpieces by the automatic centering and tilting table
- Highest axis accuracy even as the tolerances become smaller
- Reliable repeatability even for difficult measuring tasks
- Intuitive software

High load capacity

Even heavy workpieces with a weight of up to 80 kg can be measured safely using the particularly high-performance centering and tilting table.

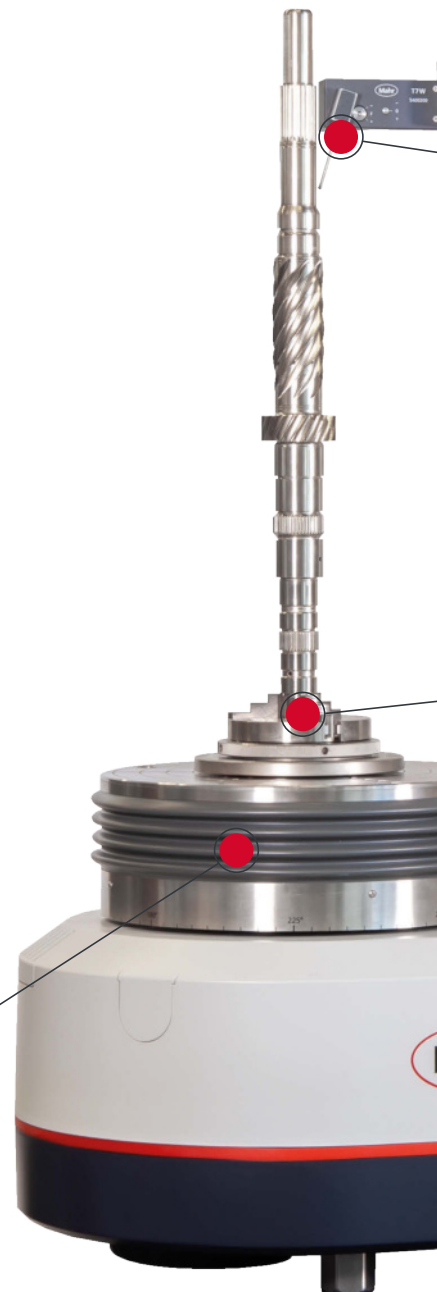

up to
100 mm/s
positioning speed

up to
80 kg
table load

0.01 μm
maximum accuracy
of the measuring axes

.5 μm
centering accuracy of the
centering and tilting table



Optimized base-to-base time

The Z-axis allows movements of up to 100 mm/s, making it more than three times faster than conventional form measuring instruments.

Fully automated probe arm replacement

The probe arm unit of the MarForm MMQ 500 holds up to four probe arms at once thus enabling the probe arm to be replaced quickly without any operator intervention.

More effective alignment

The centering and tilting table also enables complex workpieces to be aligned easily and quickly.

High measuring certainty

The mechanical bearing is up to 70 times stiffer than on comparable models making it insensitive to external influences.

MarForm. Form tester for a wide variety of applications

Form measuring instruments for workbenches or measuring rooms

In many aspects of our daily lives we put our faith in the reliable operation of technical components. From the ABS brakes, fuel injection system and gearbox in our car, to medical products such as prostheses, from the compressor in the air conditioning system to the blades on our razor, not to mention the landing flaps on our holiday airplane - the smooth interaction between moving parts is critical to their error-free function and durability. To guarantee this level of performance, rotationally symmetrical workpieces are manufactured under strict specifications for the permissible deviation from the ideal form. These tolerances can only be reliably tested with high-precision, specially optimized form testers. MarForm helps you to cut process costs, yet without driving up testing costs - by means of stable, innovative instruments offering the highest levels of accuracy. MarForm has the perfect combination for every need.

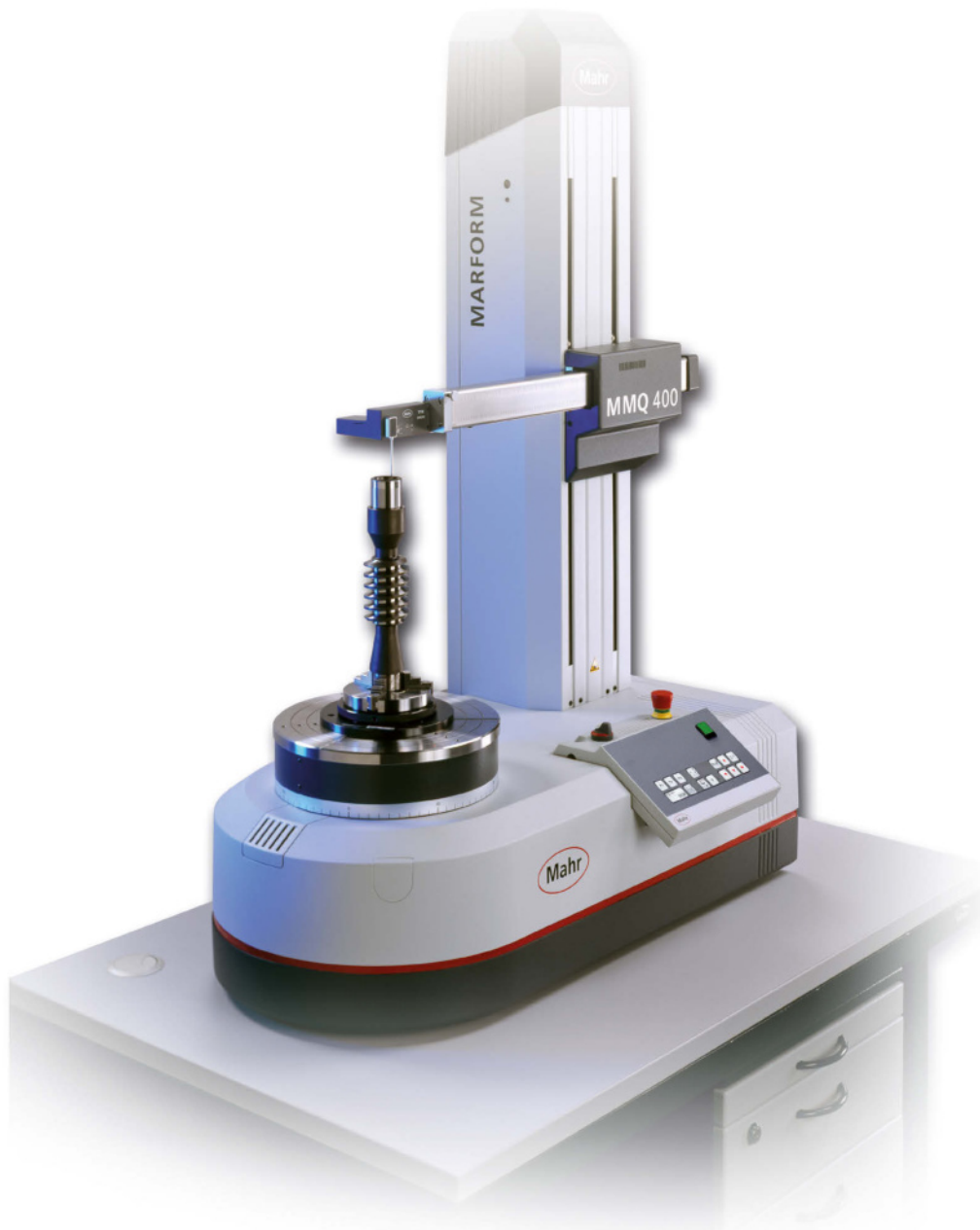
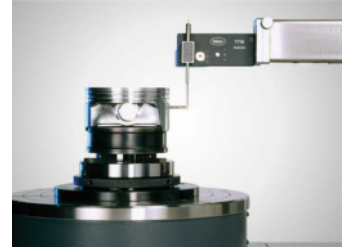
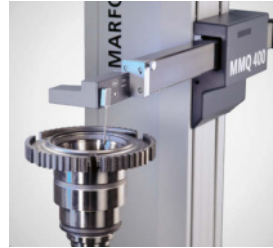

MarForm MMQ 100

Compact form measuring machine

FEATURES

The MarForm MMQ 100 form tester is the ideal solution for simple yet precise measuring tasks.

- Fast and accurate measuring results
- Mechanical bearings for reliability
- Large measuring volume
- Low weight and compact size for greater mobility
- Fast, computer aided workpiece alignment
- Centering and tilting knobs for coarse and fine adjustment
- Universal and reliable
- Workshop compatible, no compressed air connection required
- Touchscreen design eliminates the need for a keyboard or mouse
- Digital encoders in Z and X transfer the measuring position directly to the software

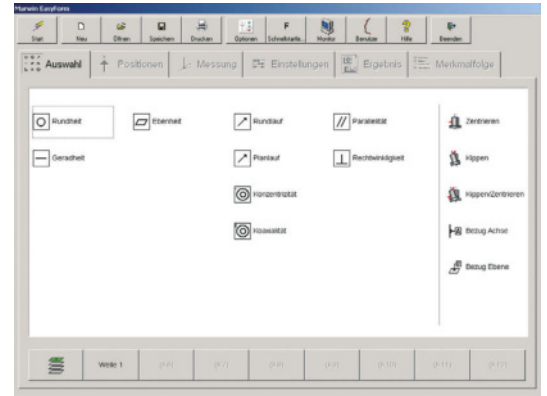

Options:

- AdvancedForm
- Mahr QE QS-STAT data export

VERSIONS

The **MMQ100** measuring station with EasyForm comes as a complete system, consists of the following:

- MarForm MMQ 100
- Digital encoders in X/Z
- T20W probe
- MarWin® EasyForm Software
- MarWin PC with WIN 10 operating system
- 24" TFT monitor
- Touch sensitive touch screen monitor (optional)



For more information, please visit our website: www.mahr.com

MarForm MMQ 150

Compact form measuring machine

FEATURES

MarForm MMQ 150 - Entry-level cylindricity measuring technology. The MMQ 150 is an automatic form tester for testing form and position tolerances:

- Use in production or in measuring rooms
- Fast and easy operation
- Measuring accuracy, optimized for cylindricity tolerances
- Less rejection, saves time, reduced production costs
- Maintenance-free, high-precision mechanical bearing

Options:

- Rim chuck Ø 100 mm
- Various additional clamps
- Commutator analysis
- Vibrational velocity analysis
- Upgrade to MarWin AdvancedForm
- 22" touch screen instead of 24" monitor
- Probe arms of various lengths and with various stylus ball geometries
- Various double probe arms
- Various calibration standards
- Various equipment tables, some with vibration compensation

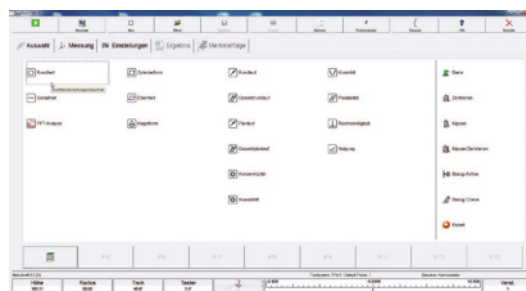

VERSIONS

The MMQ 150 measuring station, consists of the following:

- MarForm MMQ 150 form tester
- T20W length measuring probe with probe arm
- EasyForm Software for measuring and operating
- MarWin PC, Windows 10 operating system
- 24" monitor



For more information, please visit our website: www.mahr.com

MarForm MMQ 200

Compact form measuring machine

FEATURES

- Compact form measuring machine for manufacturing workshops and inspection rooms
- Proof of form and position deviations as per DIN/ISO 1101
- Fully automatic measuring sequences
- Precision roundness measuring axis (C)
- Motorized vertical measuring axis (Z)
- Motorized horizontal positioning axis (X)
- Manual centering and tilting table
- T20W manual length measuring probe or
- T7W motorized probe
- Ergonomic control panel, can also be used to start select measuring programs (P1, P2, P3)

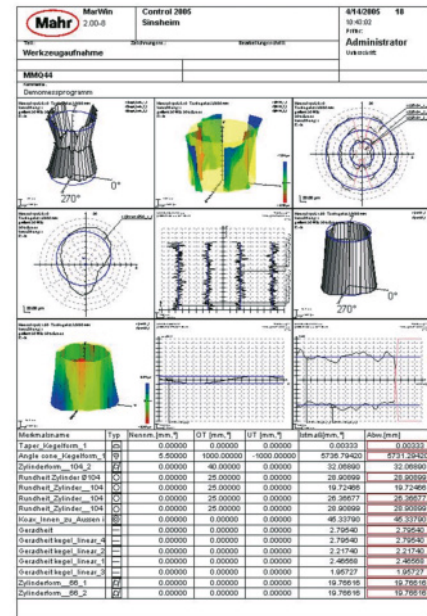

Options:

- 22" touchscreen TFT monitor instead of the 24" standard TFT
- Roughness measurement and evaluation with MMQ 200/T7W
- MarWin Software, diameter evaluation
- Various clamps
- Probe arms of various lengths and with various stylus ball geometries
- Various double probe arms
- Various calibration standards

VERSIONS

- The MarForm **MMQ 200** is available in two versions: As a measuring station with the universal measuring probe **T20W** and as a measuring station with the motorized measuring probe **T7W**, which takes automation another step forward with its unique motorization.
- The **MMQ 200** is operated with the **EasyForm** software. It is controlled by means of touchscreen technology, which also makes operation with the mouse exceptionally easy.

Form measuring station with T20W

- MarForm MMQ 200 form tester
- T20W length measuring probe, manual, with probe arm
- EasyForm measuring and operating software
- Intel-class PC, Windows 10
- 24" TFT monitor
- Rim chuck Ø 100 mm

Form measuring station with T7W

- MarForm MMQ 200 form tester
- T7W length measuring probe with probe arm
- EasyForm measuring and operating software
- Intel-class PC, Windows 10
- 24" TFT monitor
- Rim chuck Ø 100 mm



For more information, please visit our website: www.mahr.com

MarForm MMQ 400

Universal form measuring machine

FEATURES

- MarForm MMQ 400 is suitable for universal use for extensive workpiece evaluation according to DIN ISO 1101.
- High-precision measuring axes in Z and X make every form measuring task possible. There are MarForm MMQ 400 versions available for
- High-precision workpieces
- Unusually long workpieces
- Large and heavy workpieces
- Use in production or in inspection rooms
- Choose from a range of modules available to optimally customize the MarForm MMQ 400 to your requirements:
- Motorized or manual centering and tilting table
- Vertical axis (Z) with a 900 mm, 500 mm or 350 mm measuring length
- Horizontal axis (X) with a 180 mm or 280 mm measuring length and with digital linear scales in axes X and Z. For measurements where finding the exact, reproducible measuring position affects the result
- Manual or fully automatic probe with short measuring circle, high linearity, low measuring force.
- **Path control for quick measurement of a nominal contour**
- optionally with **motorized tailstock for shafts longer 200 mm**

Options:

- Roughness measurement
- Switch between form probe with ruby ball and roughness probe PHT 6–350
- Piston testing with MarWin Evaluation Software
- Shaft twist testing and analysis with MarWin
- Cam profile testing
- Bar to bar variation analysis at commutators
- Contour measurement and evaluation
- Path control (MCPC)
- Free form evaluation
- Vibrational velocity analysis
- Dominant roundness waviness (MBN 10455)

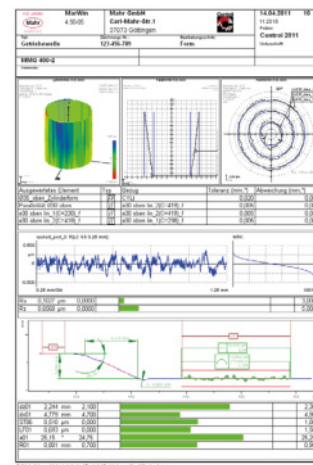

For more information, please visit our website: www.mahr.com

MarForm MMQ 100 / MMQ 150 / MMQ 200 / MMQ 400

Compact form measuring machine

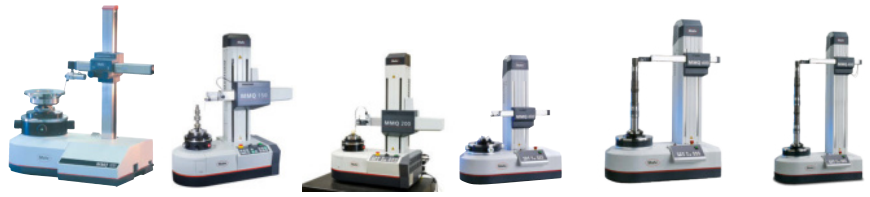

| Tabletop form tester overview | MMQ 100 | MMQ 150 | MMQ 200 | MMQ 400-2 Z = 350 mm X = 180 mm | MMQ 400-2 Z = 500 mm X = 280 mm | MMQ 400-2 Z = 900 mm X = 280 mm |
|--|----------------|----------------|----------------|---------------------------------------|---------------------------------------|---------------------------------------|
| Roundness measuring device, C-axis | | | | | | |
| Roundness deviation ($\mu\text{m}+\mu\text{m}/\text{mm}$ measuring height) ** | 0.05 + 0.0006 | 0.03 + 0.0006 | 0.03 + 0.0006 | 0.02 + 0.0005 | 0.02 + 0.0005 | 0.02 + 0.0005 |
| Roundness deviation ($\mu\text{m}+\mu\text{m}/\text{mm}$ measuring height) * | 0.025 + 0.0003 | 0.015 + 0.0003 | 0.015 + 0.0003 | 0.01 + 0.00025 | 0.01 + 0.00025 | 0.01 + 0.00025 |
| Axial runout deviation ($\mu\text{m}+\mu\text{m}/\text{mm}$ measuring radius) ** | 0.04 + 0.0006 | 0.04 + 0.0006 | 0.04 + 0.0006 | 0.04 + 0.0002 | 0.04 + 0.0002 | 0.04 + 0.0002 |
| Axial runout deviation ($\mu\text{m}+\mu\text{m}/\text{mm}$ measuring radius) * | 0.02 + 0.0003 | 0.02 + 0.0001 | 0.02 + 0.0001 | 0.02 + 0.0001 | 0.02 + 0.0001 | 0.02 + 0.0001 |
| Centering and tilting table | | | | | | |
| Centering and tilting table | manual | manual | manual | manual / automatic | manual / automatic | automatic |
| Table diameter | 160 | 160 | 160 | 285 | 285 | 285 |
| Table load capacity, centered (N) | 200 | 200 | 200 | 600 | 600 | 400 |
| Speed (rpm) 50 Hz / 60 Hz | 5 / 6 | 1–6 | 0.2–15 | 0.2–15 | 0.2–15 | 0.2–15 |
| Vertical unit, Z-axis | | | | | | |
| Positioning path (mm) Z axis | 300, manual | - | - | - | - | - |
| Z axis positioning | manual | - | - | - | - | - |
| Measuring path, motorized Z (mm) | - | 250 | 250 | 350 | 500 | 900 |
| Straightness deviation / 100 mm measuring path (μm)**, Z axis | - | 0.4 | 0.15 | 0.15 | 0.15 | 0.15 |
| Straightness deviation / total measuring path (μm)**, Z axis | - | 1 | 0.3 | 0.3 | 0.4 | 0.9 |
| Parallelism deviation Z-/C axis in tracing direction, measuring path (μm) | - | 1 | 0.5 | 0.5 | 0.8 | 2 |
| Measuring speed (mm/s), Z axis | - | 0.5–30 | 0.5–30 | 0.1–30 | 0.1–30 | 0.1–30 |
| Positioning speed (mm/s), Z axis | - | 0.5–50 | 0.5–100 | 0.5–100 | 0.5–100 | 0.5–100 |
| Horizontal unit, X axis | | | | | | |
| Positioning path (mm), X axis | 180, manual | 150, motorized | 150, motorized | - | - | - |
| Measuring path, motorized X (mm) | - | - | - | 180 | 280 | 280 |
| Straightness deviation / 100 mm measuring path (μm)**, X-axis | - | - | - | 0.4 | 0.5 | 0.5 |
| Straightness deviation / total measuring path (μm)**, X axis | - | - | - | 0.8 | 1.5 | 1.5 |
| Perpendicularity X/C axis, measuring path (μm) | - | - | - | 1 | 2 | 2 |
| Positioning speed (mm/s), X axis | - | 0.5–30 | 0.5–30 | 0.5–30 | 0.5–30 | 0.5–30 |
| Measuring speed (mm/s), X axis | - | - | - | 0.5–10 | 0.5–10 | 0.5–10 |

* Values as maximum deviation from LSC reference circle, filter 15 undulations/revolution.

** All values in accordance with DIN ISO 1101 at 20°C ±1°C in a vibration-neutral environment, filter 15 undulations/revolution LSC or 2.5 mm LSS, 5 rpm or 5 mm/s and standard probe arm with ball diameter 3 mm. Proof at the standard using error separation techniques. Given the number of different options available, only a few machines are described here by way of example. Technical data for "your" MMQ is available from Mahr on request



For more information, please visit our website: www.mahr.com

MarForm MMQ 500

Universal form measuring machine

FEATURES

The MarForm MMQ 500 is the best choice among tabletop form testers due to its wide range of options for high-precision measurement. Due to its optimized machine design, it can be used universally and enables maximum utilization.

- Universally applicable for small workpieces of a few millimeters in size up to heavy workpieces up to 80kg
- Intuitive to use software
- Highest axis accuracy even with decreasing tolerances
- Best repeatability even with difficult measuring tasks
- Measurement of form, position, roughness, contour and twist in one measuring sequence



TECHNICAL DATA

| MMQ 500 | |
|---|----------------|
| Diameter max.* (mm) | 530 |
| Measuring distance Z (mm) | 470 |
| Type | MMQ 500 |
| Roundness deviation ($\mu\text{m}+\mu\text{m}/\text{mm}$ measuring height)** | 0.02 + 0.0005 |
| Roundness deviation ($\mu\text{m}+\mu\text{m}/\text{mm}$ measuring height)* | 0.01 + 0.00025 |
| Axial run-out deviation ($\mu\text{m}+\mu\text{m}/\text{mm}$ measuring radius)** | 0.04 + 0.0002 |
| Axial run-out deviation ($\mu\text{m}+\mu\text{m}/\text{mm}$ measuring radius) | 0.02 + 0.0001 |
| Centering and tilting table | automatic |
| Table diameter | 300 |
| Table load capacity, centered (N) | 800 |
| Straightness deviation / total measuring path (μm)** | 0.3 |
| Parallelism deviation Z-/C-axis in tracing direction (μm) | 0.6 |
| Measuring speed (mm/s), Z axis | 100 |

* Values as maximum deviation from LSC reference circle, filter 15 undulations/revolution.

** All values in accordance with DIN ISO 1101 at 20°C \pm 1°C in a vibration-neutral environment, filter 15 undulations/revolution LSC or 2.5 mm LSS, 5 rpm or 5 mm/s and standard probe arm with ball diameter 3 mm. Proof at the standard using error separation techniques. Given the number of different options available, only a few machines are described here by way of example. Technical data for "your" MMQ is available from Mahr on request

MarForm MFU 200

Reference form measuring station

FEATURES

- Reference form measuring station in a new dimension
- The journey from high precision measuring axes to competent measurements is often a long one that the **MFU 200** has mastered completely. Only the **MFU 200** has integrated reference elements for the real-time spatial compensation of geometric deviations, recording all profiles as high precision 3D coordinates.
- For decades, **MarForm** measuring machines have been recognized for their accuracy and stability. The **MFU 200** was developed with the claims of testing the shape and position features of product parts in a one liter measuring volume close to the production area and at a reasonable cost. In doing so, it has taken our long experience into a new dimension.
- **MFU 200** is a precision reference form measuring center. Its exceptionally low measurement uncertainty increases the tolerance margin for your production processes, thereby lowering production costs.

The form measuring center consists of the following components:

- Circular roundness measuring axis (C)
- Motorized centering and tilting table (X, Y, A, B)
- Roundness measuring axis circular (C- high-speed, up to 200 U/min)
- Vertical straightness measuring axis (Z)
- Horizontal straightness measuring axis (X)
- Tangential multifunction axis (Y)
- Motorized length measuring probe T7W
- MarWin Evaluation Software for form and position features
- The consistent separation of control and evaluation makes **MFU 200** future-proof and expandable. New language versions can be implemented just as effectively as special evaluations and new standards. The **MFU 200** is also already prepared for the use of optical sensor technology, the MarForm IPS, and can thus also measure micro surface structures with high precision.
- In short: **MFU 200** brings form measuring machines for inspection rooms and production areas into a new dimension.



TECHNICAL DATA

| MFU 200 | |
|---------------------------|--|
| Type | MFU 200 |
| Monitor | 19" TFT monitor (touchscreen monitor) |
| Control panel | MCP 12 |
| Motorized measuring probe | T7W |
| Probe arm | 60 mm ø 1.0, ruby, M2, 60 degrees, prepared for the connection of the optical sensor IPS15 |
| Pitch error | Pitch error of the C-/Z-/X-axis is calibrated |

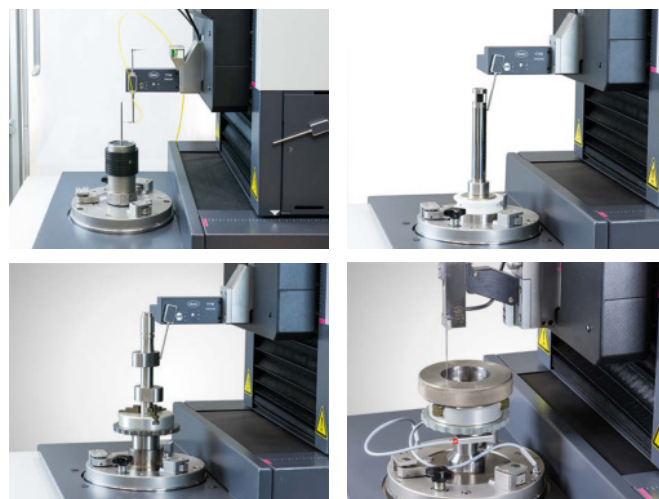

APPLICATIONS

- Checking product parts for form and position features
- Roundness, concentricity / coaxiality, cylindricity, concentricity, axial runout, radial runout, total runout, straightness, parallelism, squareness, inclination, flatness, conicity, diameter, taper, Fourier analysis (waviness analysis), line profile, area profile, cam shape
- Recording of all profiles as high-precision 3D coordinates with real-time
- Spatial compensation of geometric deviations
- Scanning of surfaces, roughness evaluation
- Scanning and evaluation of contours and shapes

Probe arms for T20W probe

Ident-Nr.: 5400160

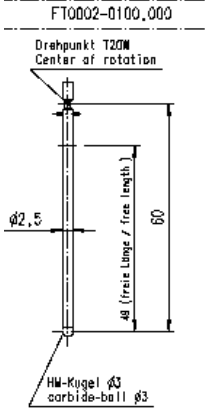

Ident-Nr.: 5400161

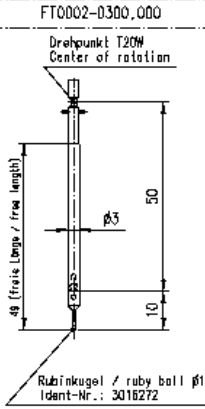

Ident-Nr.: 5400162

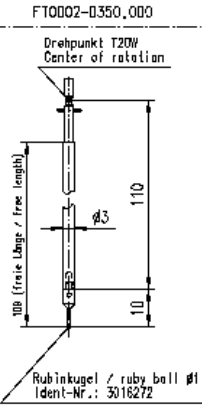

Ident-Nr.: 5400170

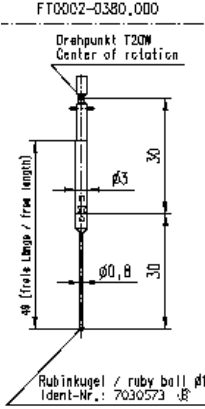

Ident-Nr.: 5400163

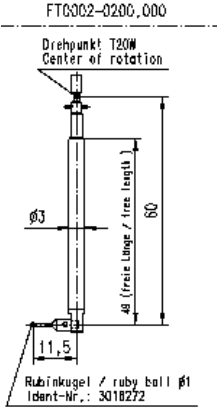

Ident-Nr.: 5400164

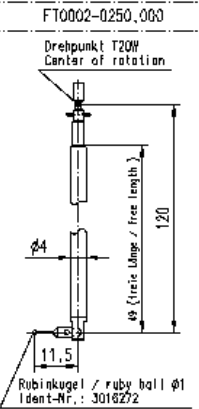

Ident-Nr.: 5400169

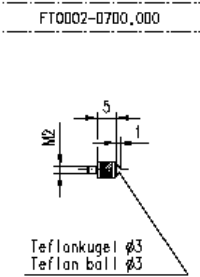

Ident-Nr.: 5400165

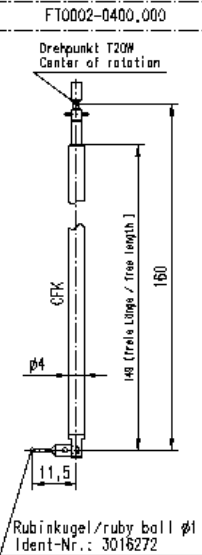

Ident-Nr.: 5400166

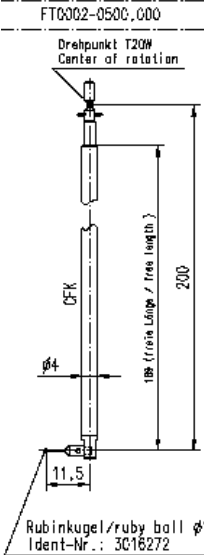

Ident-Nr.: 5400167

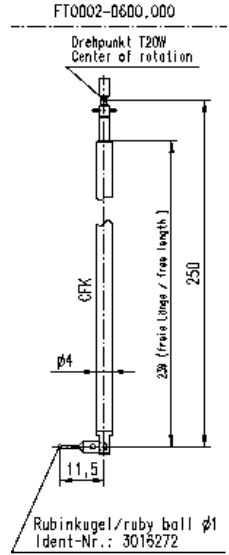

Taststifte / Stylus M2

| Ident-Nr. | Kugel- ϕ [mm] ball- ϕ [mm] | Material | Wirklänge [mm] operation length [mm] |
|-----------|---|------------|---|
| 4662093 | 0,3 | Ruby/ruby | 10 |
| 4662090 | 0,5 | Ruby/ruby | 10 |
| 3016272 | 1,0 | Ruby/ruby | 10 |
| 8156089 | 1,0 | Ruby/ruby | 20 |
| 8154125 | 1,5 | Ruby/ruby | 10 |
| 8154398 | 3,0 | Ruby/ruby | 10 |
| 8159402 | 5,0 | Ruby/ruby | 20 |
| 8162168 | 1,0 | HM/carbide | 10 |
| 8049415 | 1,5 | HM/carbide | 10 |
| 8162164 | 2,0 | HM/carbide | 10 |
| 8159618 | 3,0 | HM/carbide | 20 |
| 8049416 | 5,0 | HM/carbide | 20 |

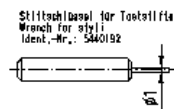

Ident-Nr.: 5400168

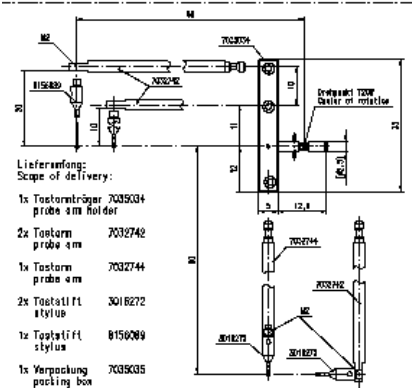

- Lieferumfang:
Scope of delivery:
- 1x Tastorträger 7035034 probe arm holder
 - 2x Tastarm 7032742 probe arm
 - 1x Tastarm 7032744 probe arm
 - 2x Taststift 3016272 stylus
 - 1x Taststift 8156089 stylus
 - 1x Verpackung 7035035 packing box

The optimal solution using accessories

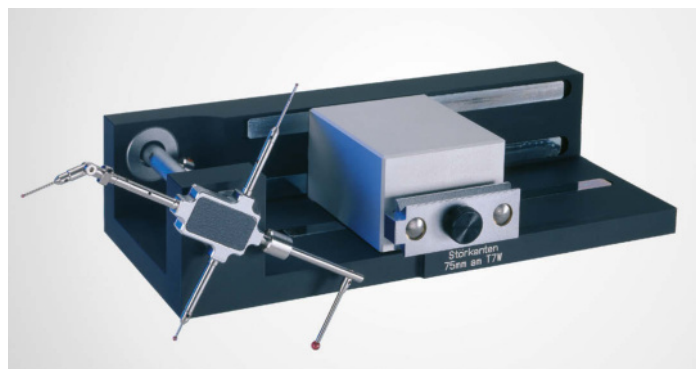

Device for balancing probe arms



Motor-driven T7W probe

The T7W probe is fitted with a motor-driven rotational axis. This makes it possible to move the probe arm gradually to the required contacting position. As a result, measurements can be performed on cylindrical surfaces and end faces. As a zero position probe, the T7W can also switch automatically between internal and external measurements or between end face measurements from above and below without operator intervention. Fully automatic measurement processes on complex workpieces can be carried out without operator intervention too. The probe arms of the T7W are exchangeable. Its motor-driven rotational axis enables the construction of „multi-point probe arms“ - i.e. probe arms with a variety of contacting elements - making it possible to switch between different stylus ball geometries within a single measurement run.

Motor-driven T7W probe with probe arm range of 360° for MMQ 400 and MMQ 400 CNC Order No. 5400200

- Total measuring range of 2.000 µm (0.079“)
- Zero probe with a working range of ± 500 µm (± 0.0197“)
- Measuring force adjustable from 0.01 to 0.2 N
- Two-way measuring direction
- Contacting angle freely selectable in 1° steps
- 360° adjustable (motor-driven)
- Probe arms easily exchangeable (magnetic mount)
- Flexible multi-point probe possible
- Mechanical and electrical overload protection

Accessories for motor-driven T7W probe

Probe arm module for T7W Order No. 5400221
in storage case, consisting of:

- | | |
|---|----------------------------------|
| Stylus arm dia. 0.5 mm, L=20 mm, M2a | Weight 5.0 g |
| Stylus arm dia. 1.0 mm, L=20 mm, M2a | Probe arm L=15 mm 2x M2 |
| Stylus arm dia. 1.0 mm, L=15 mm, M2a | Stylus arm extension 10 mm, M2 |
| Stylus arm dia. 1.5 mm, L=10 mm, M2a | Stylus arm extension 20 mm, M2 |
| Stylus arm dia. 3.0 mm, L=10 mm, M2a | Stylus arm extension 30 mm, M2 |
| Stylus arm dia. 3.0 mm, L=25 mm, M2a | Stylus arm extension 40 mm, M2 |
| Weight 1.5 g | Rotary swivel joint M2 |
| Weight 1.0 g | Hex head screwdriver A/V 1.5 |
| Weight 2.0 g | Hex head screwdriver A/V 0.9 |
| Weight 3.0 g | Rotary part M2, concentric |
| Weight 0.5 g | Wrench 1.0 |
| Weight 10.0 g | Stylus arm holder M2i transverse |
| | Stylus arm holder M2i axial |
| | Stylus M2i transverse |
| | Mount 2x M2i transverse |
| | Guide |
| | Adjuster |

ACCESSORIES

| Order no | Description |
|----------|--|
| | Hardware (mandatory item): |
| 9028023 | Calibration sphere Ø 15 mm with Mahr calibration certificate |
| 9064901 | with MarWin PC with WINDOWS 10, multi-lingual |
| 3026857 | Wireless keyboard K400 plus Logitec, German |
| 3026858 | Wireless keyboard K400 plus Logitec, English |
| 6710620 | Three-jaw chuck with flange, Ø 100 mm, not to be used with basic holder |
| 3017216 | Basic holder for quick clamp/retriever interface |
| 9004831 | Rim chuck with three jaws, Ø 50 with column and flange for MFU quick clamp |
| | Software (optional/mandatory item): |
| 5480312 | ProfessionalForm software |
| 5480311 | AdvancedForm software |
| | Optical sensor for MFU 200 plus: |
| 5400275 | Interferometric controller with IPS15, including rack to hold the IPS box |

Further, extensive accessories on request



Three-jaw chuck with column



Calibration sphere



Rim chuck

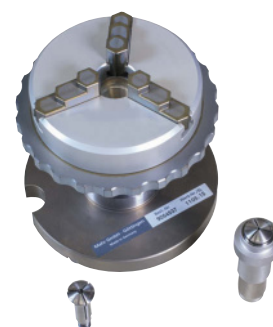

Rim chuck with collet chucks

MarGear | Gear measuring instruments

MarGear metrology allows you to carry out your measuring tasks on gears and gear cutting tools quickly, simply and accurately, in just one measuring process. The flexible systems, create the best possible conditions for gaining and retaining a competitive edge. With or without mechanical alignment and reclamping, and with a combination of gear metrology, form and position evaluation. By fully integrating metrology into production, you can achieve a closed quality control loop in transmission manufacturing.



| | |
|---|------------|
| MarGear GMX 400 W Universal gear measuring center | 622 |
| MarGear GRP1 Roughness probe system | 623 |



The latest information about MarGear products is available on our website: www.mahr.com

MarGear. GMX W series

Opening up a new dimension

The W series extends the MarWin® platform to Mahr gear measurement

- MarEcon control unit with tracking mode
- Gear testing software runs under MarWin (option)
- Intuitive GDE interface for gear data (option)
- MarForm Advanced and Professional (option)
- Easy program creation in teach-in mode
- Integration of data matrix code scanners (option)
- Uninterrupted movements
- High precision target positioning
- 3D visualization of gear geometry

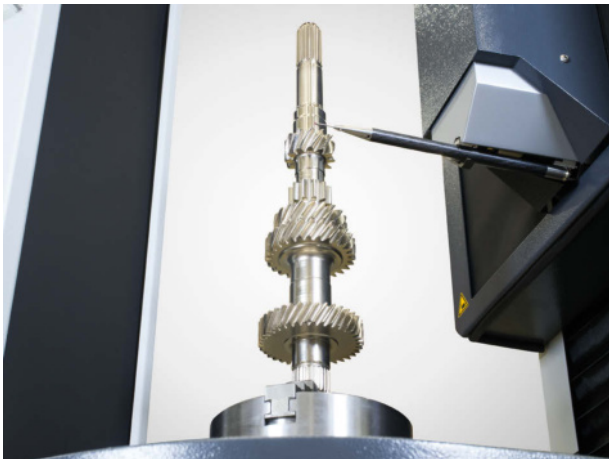
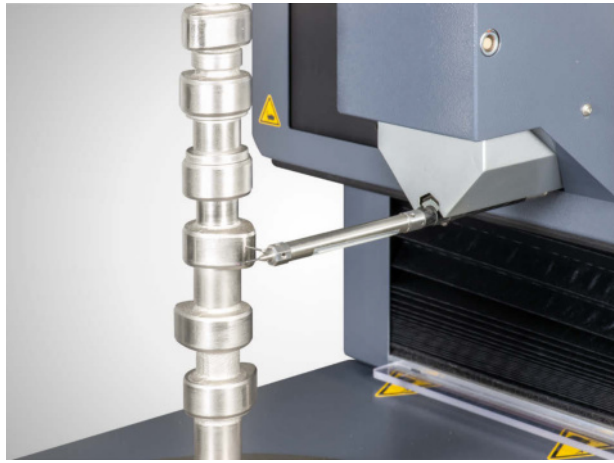
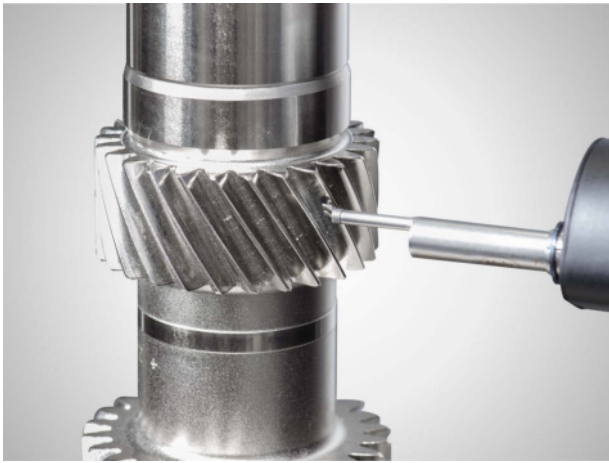

MarGear. GMX W series

Opening up a new dimension



MarGear GMX 400 W

Universal gear measuring center

FEATURES

- Precision, fully automatic testing of gears up to an outer diameter of 400 mm
- Combining gear measuring tasks with various form and position features has never been easier
- With over 6000 units sold, the MarWin environment is a clear and simple way of creating complete programs in teach-in mode
- Improves programming efficiency and reduces the possibility of incorrect use
- Proven GMX realtime machine error correction is also used for positioning movements with the new MarEcon control unit, guaranteeing maximum speed and precision throughout the entire measuring and movement sequence
- **Gear, form and 3D measurements** are performed on one measuring instrument
- **High-precision 3D scanning sensor** combined with directly driven C-axis for accuracy and efficiency
- GDE interface: "Closed loop" for cylindrical gears
- With tailstock option
- Gear measuring instrument, accuracy class 1, for gear measurements in accordance with VDI/VDE 2612/2613 Group 1 at 20°C ± 2 K (rotational axis in formtester accuracy)



TECHNICAL DATA

| GMX 400 W | |
|--|---|
| Measuring path X (mm) | 200 |
| Measuring path Y (mm) | 200 |
| Measuring path Z (mm) | 320 |
| Diameter max.* [mm] | 400 |
| Length | 1520 |
| Width | 621 |
| Height | 1920 |
| Mass [kg] | 760 |
| Max. workpiece weight [kg] | 60 |
| Accuracy | Accuracy class I for gear measurements in accordance with VDI/VDE 2612/2613 Group 1 at 20°C ± 2°C |
| Axial runout deviation ($\mu\text{m} + \mu\text{m}/\text{mm}$ measuring radius) | 0.11 μm + 0.0008 $\mu\text{m}/\text{mm}$ |
| Radial runout deviation (μm in table height) | $\leq 0.11 \mu\text{m}$ |

* Max. diameter of cylindrical gears

APPLICATIONS

Fully automatic testing of:

- Straight and helical toothed cylindrical gears
- Form and position measurements
- Diameters and lengths

ACCESSORIES

- Data matrix scanner
- Range of chucks for "clamping on the fly" and measurements on "virtually" aligned workpieces (wobble coordinate system)
- Roughness probe GRP1



For more information, please visit our website: www.mahr.com

MarGear GRP1

Roughness probe

FEATURES

- Expansion package for roughness measurement and analysis on gears
- In the field of gear metrology, Mahr already offers highly accurate reference systems that combine gear measurement with the measurement of diameters or form. Moreover in the field of surface metrology, we at Mahr have brought the worldwide styling method to perfection.
- So what could be more obvious than to measure and document roughness parameters such as Ra and Rz when testing your workpieces with a gear measuring device?
- As a specialist for inductive probes, Mahr combines the advantages of its self-developed universal 3D probe with the precision of the proven roughness probe PHT. Gear and roughness measurement grow together.
- Combine the gear analytical measurement with roughness characteristics monitoring on the MarGear GMX series gauging centers. Simultaneously document typical roughness parameters such as Ra and Rz during inspection without reclamping the workpiece on another measuring station. The superior positioning accuracy of the MarGear GMX combined with the new motorized swivel axis of the MarGear roughness probe ensures maximum reproducibility.

Your advantages:

- Miniaturized roughness probe for gears from module 0.8
- The MarWin platform allows the use of our known roughness software for surface metrology at the gear measuring center
- Automatic swivel axis of the roughness probe enables standard surface measurement even on helical gears
- Characteristic values e.g. according to ISO 4287 or ISO 13565-2



APPLICATIONS

- Roughness at teeth flanks
- Roughness at bearing positions



For more information, please visit our website: www.mahr.com

MarShaft | Shaft measuring instruments

The role of metrology is changing, to keep pace with innovations in manufacturing processes. Given the continual stringent accuracy requirements and falling cycle times, rapid measurement directly at the manufacturing machine is absolutely essential. Flexible MarShaft metrology from Mahr is the right solution for quick and accurate measurement in production.



| | |
|---|------------|
| Overview MarShaft | 626 |
| Shaft measuring instruments | |
| MarShaft SCOPE 250 plus | 631 |
| Universal, fully automatic optical shaft measuring system | |
| MarShaft SCOPE plus | 632 |
| Optical shaft measuring system | |
| MarShaft SCOPE 600 plus 3D | 633 |
| Optical shaft measuring system | |
| MarShaft accessories | 634 |
| MarShaft Software EasyShaft | 636 |



The latest information about MarShaft products
is available on our website: www.mahr.com

MarShaft SCOPE 600 plus 3D – Universal measuring machine in production

Best performance

also suitable for use in workshop environments, short paths, increase in measuring capacity, no wait times

Measurements without user intervention

The measuring sequences are fully automatic, completely free of user influences, reliable measuring results, avoidance of measurement errors

Quick and easy

Quick measurement and quality reading of the workpiece prevents waste and increases productivity in production

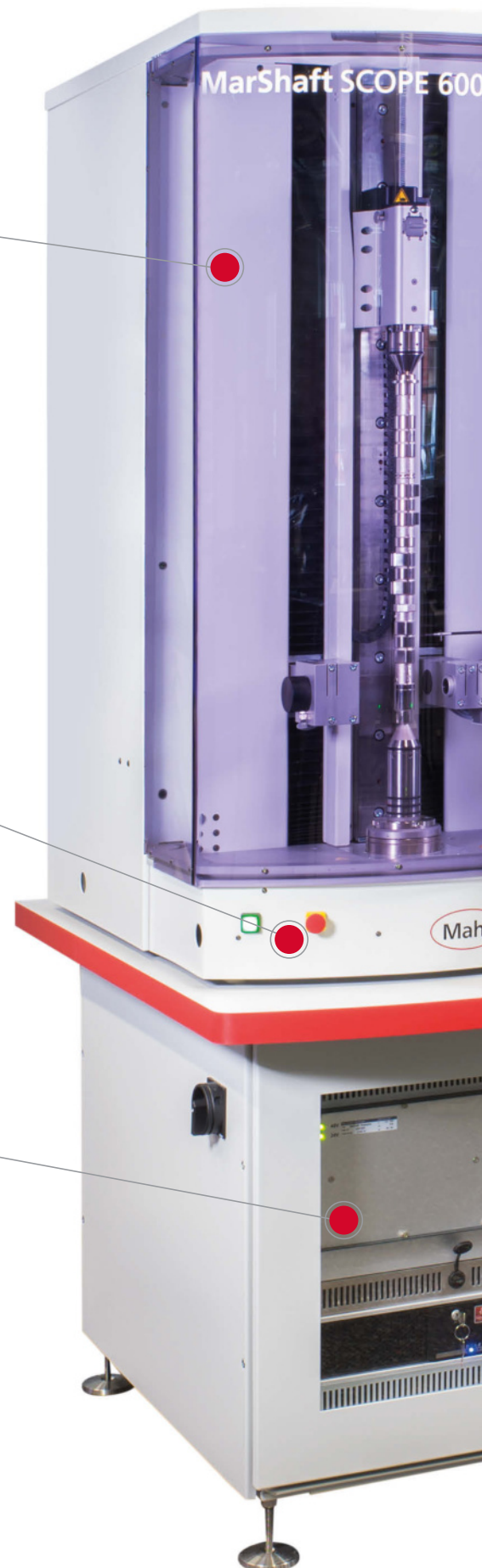



Flexible layout

9 different versions for maximum precision - through customized solutions

Flexible and universal measuring machine

5 measuring machines in one, shaft measuring machine, formtester, contour measuring instrument, 3D measuring machine and gear measuring instrument

Software platform

One user-friendly software, MarWin platform for shafts, form, gears, and contours

MarShaft

Shaft measuring instruments

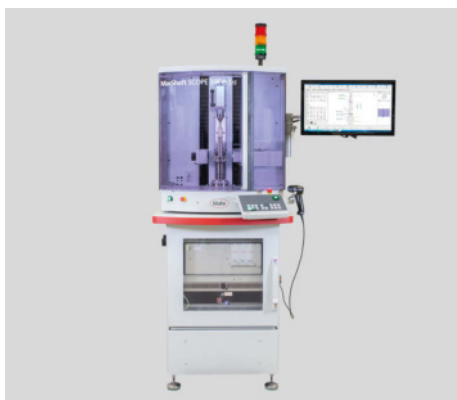

| Shaft measuring instruments overview | SCOPE 250 plus 5361802 | SCOPE 350 plus 5361507 | SCOPE 750 plus 5361508 |
|--------------------------------------|---|--|--|
| Order no. | | | |
| Measuring range length (Z) (mm) | 250 | 350 | 750 |
| Measuring range diameter (X) (mm) | 40 | 120 | 120 |
| Workpiece weight (max.) in kg | 5 | 15 (optional 30) | 15 (optional 30) |
| Length/diameter resolution (mm) | 0.01 to 0.0001 | 0.01 to 0.0001 | 0.01 to 0.0001 |
| Angle resolution (°) | 0.01 to 0.0001 | 0.01 to 0.0001 | 0.01 to 0.0001 |
| Length error limit (Z) (µm) | $\leq (3.0 + L/125)$ L in mm | $(2 + L/125)$ L in mm (at 20 °C ± 1 °C on reference standard) | $(2 + L/125)$ L in mm (at 20 °C ± 1 °C on reference standard) |
| Diameter error limit (X) (µm) | $\leq (1.5 + L/40)$ L in mm | $(1.0 + L/125)$ L in mm (at 20 °C ± 1 °C on reference standard) | $(1.0 + L/125)$ L in mm (at 20 °C ± 1 °C on reference standard) |
| Drives | Servo motors | Servo motors | Servo motors |
| Optics | Telecentric precision lens high-resolution CMOS camera | Telecentric precision lens high-resolution CCD array | Telecentric precision lens high-resolution CCD array |

MarShaft

Shaft measuring instruments



| Shaft measuring instruments overview | SCOPE 1000 plus | SCOPE 600 plus 3D |
|--------------------------------------|---|---|
| Order no. | 5361516 | 5361522 |
| Measuring range length (Z) (mm) | 1000 | 600 |
| Measuring range diameter (X) (mm) | 120 | 120 |
| Workpiece weight (max.) in kg | 15 (optional 30) | 15 |
| Length/diameter resolution (mm) | 0.01 to 0.0001 | 0.01 to 0.0001 |
| Angle resolution (°) | 0.01 to 0.0001 | 0.01 to 0.0001 |
| Length error limit (Z) (µm) | $(3 + L/125)$ L in mm (at 20 °C ± 1 °C on reference standard) | $(2 + L/125)$ L in mm (at 20 °C ± 1 °C on reference standard) |
| Diameter error limit (X) (µm) | $(1.50 + L/125)$ L in mm (at 20 °C ± 1 °C on reference standard) | $(1.0 + L/125)$ L in mm (at 20 °C ± 1 °C on reference standard) |
| Drives | Servo motors | Servo motors |
| Optics | Telecentric precision lens high-resolution CCD array | Telecentric precision lens, high-resolution CCD array |

MarShaft. Measurement of shaft-type parts in production.

MarShaft measuring instruments are mostly used in production. However, with their high measuring accuracy they can also be used in measuring laboratories. The instruments are available in various sizes, and their modular design allows them to be optimized to individual measuring tasks. Inline measurement directly in the manufacturing process saves the time and expense of measurements in the measuring room and increases productivity.

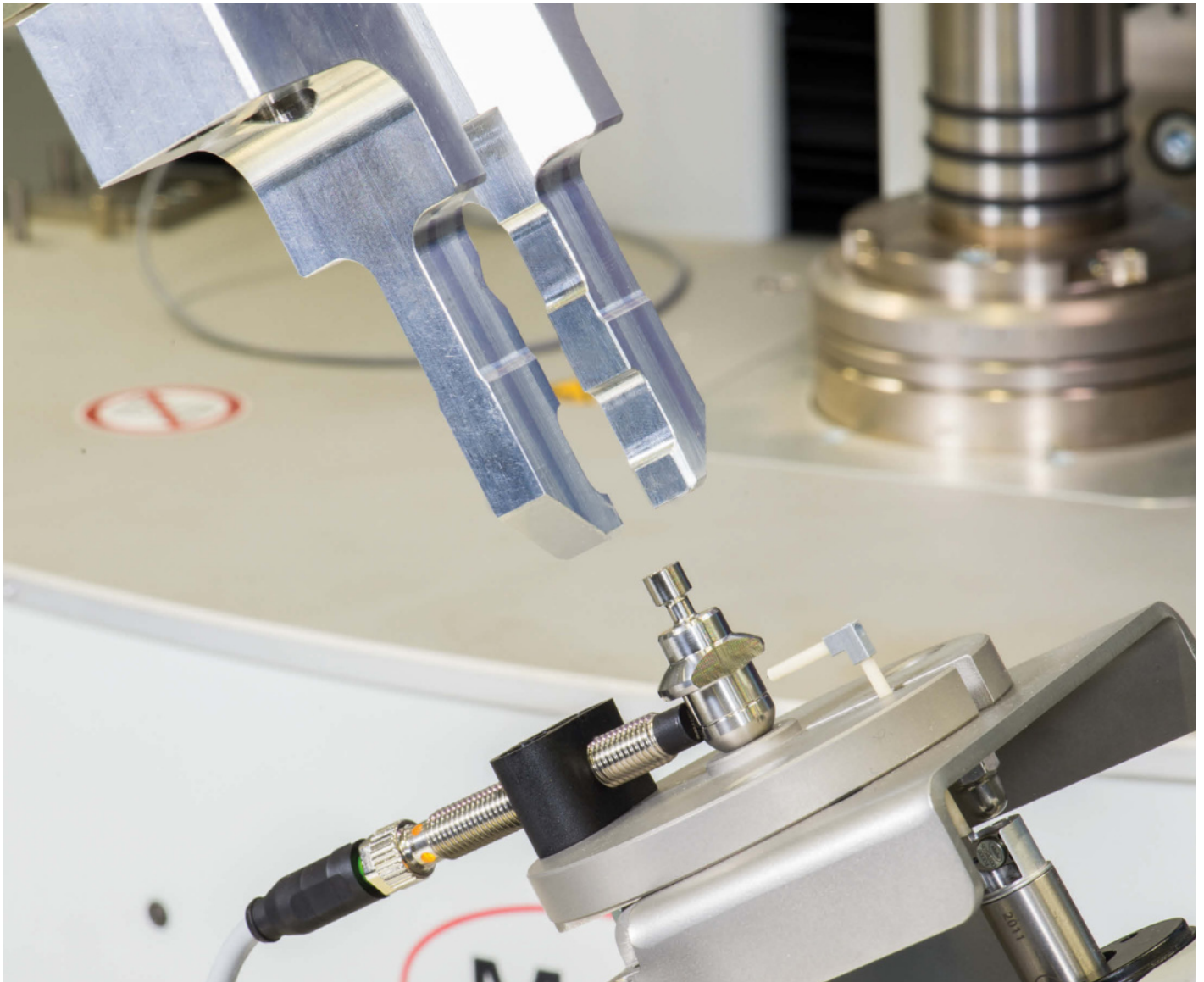

MarShaft SCOPE 250 *plus*

Fully automatic universal optical shaft measuring system

DESCRIPTION

The role of dimensional metrology is expanding at a dramatic rate, in parallel with innovations in manufacturing processes. Given the ever more stringent accuracy requirements and falling cycle times in production (turning, milling, grinding, etc.), rapid measurement directly at the manufacturing machine is absolutely essential. Measurement at the point of origin of the product, with rapid feedback to the manufacturing process to avoid waste. Mahr's flexible MarShaft SCOPE 250 *plus* shaft measuring machine offers the right measuring solution for the fast, precise and fully automatic measurement of rotationally symmetrical workpieces in production.

The MarShaft SCOPE 250 *plus* has a high precision roundness measuring axis (C) and a vertical measuring axis (Z) with a measuring range of 250 mm. At its heart is the state-of-the-art, high-resolution CMOS matrix camera (live image) with an image field of 1088 x 2048 mm. The extremely high image acquisition rate of over 120 images per second keeps measuring times to a minimum. Zoom functions allow the smallest details to be measured, which with conventional measuring methods are difficult if not impossible to test.

Performance features at a glance:

- New, high-resolution CMOS matrix camera with a 40 mm live image field allows fast scanning with over 120 images per second
- High accuracy for diameter and length measurement
- Measuring speeds of up to 200 mm/s result in extremely fast measuring times
- By using Mahr's MarWin software platform, you can benefit from our decades of experience in length, form, position and contour measurement
- Excellent entry level price into the small optical shaft measuring machine segment



TECHNICAL DATA

| Order no. | 5361802 |
|-----------------------------------|---|
| Measuring range length (Z) (mm) | 250 |
| Measuring range diameter (X) (mm) | 40 |
| Length/diameter resolution (mm) | 0.01...0.0001 |
| Angle resolution (°) | 0.01...0.0001 |
| Length error limit (Z) (µm) | ≤ (3.0+I/125) L in mm |
| Diameter error limit (X) (µm) | ≤ (1.5+I/40) L in mm |
| Lens | Telecentric precision optics High-resolution CMOS camera |
| Drives | Servo motors |
| Lens | Telecentric precision optics high-resolution CMOS camera |

APPLICATIONS

To measure:

- Length
- Diameter
- Form and position tolerances
- Offsets
- Recess width
- Bevel width
- Intersection points
- Position of intersection points
- Angles of rotation
- Radii
- Position of radii
- Taper lengths
- Angles
- Pitches
- Widths across flats
- Outer threads



For more information, please visit our website: www.mahr.com

MarShaft SCOPE plus

MarShaft SCOPE 350 / 750 / 1000 plus optical shaft measuring systems

DESCRIPTION

- The **MarShaft SCOPE plus** is a universal, fully automatic optical shaft measuring system for testing rotationally symmetrical workpieces.
 - The **MarShaft SCOPE plus** has a highly accurate roundness measuring axis (C), a vertical measuring axis (Z) and a horizontal measuring axis (X).
 - A tactile measuring system with an inductive measuring probe is available as an option, for measuring radial and axial runout, for example. The measuring device is calibrated to the optical measuring system, so it can perform tactile and optical measuring tasks in combination.
 - The new MarWin EasyShaft software provides a high level of flexibility and exceptionally user-friendly operation.
 - The measuring sequences are carried out fully automatically, free from operator influences.
 - The MarShaft SCOPE plus is suitable for use in both the workshop environment and in the inspection room. Zoom functions allow the smallest details to be measured, which with conventional measuring methods are difficult if not impossible to test.
 - Automatic measuring procedure
 - Matrix camera, 1280 x 1024 pixels
 - User-friendly touchscreen operation
 - One measuring instrument for multiple measuring tasks
 - Good workshop compatibility
 - MarWin EasyShaft software provides a high level of flexibility and user-friendly operation
- Options:**
- Tactile measuring unit for measuring radial run-out and axial run-out
 - Temperature compensation
 - Thread measurement
 - Turbocharger shaft measurement
 - Manual control panel
 - Signal lamp
 - Barcode scanner
 - MarWin Professional Shaft software
 - QS-Stat interface



TECHNICAL DATA

| Order no. | 5361507/5361508/5361516 |
|-----------------------------------|--|
| Measuring range length (Z) (mm) | 350 / 750 / 1000 |
| Measuring range diameter (X) (mm) | 80 or 120 |
| Workpiece weight (max.) in kg | 15 (optional 30) |
| Length/diameter resolution (mm) | 0.01 to 0.0001 |
| Angle resolution (°) | 0.01 to 0.0001 |
| Length error limit (Z) (µm) | (2 + L/125) L in mm / (3 + L/125) L in mm (at 20°C ± 1°C on reference standard) |
| Diameter error limit (X) (µm) | (1.0 + L/125) L in mm / (1,5 + L/125) L in mm (at 20°C ± 1°C on reference standard) |
| Drives | Servo motors |
| Lens | Telecentric precision lens high-resolution CCD array |

APPLICATIONS

Typical workpieces

- Turned parts
- Tripods
- Transmission shaft
- Rack
- Axle journal
- Hollow shaft
- Drive shaft
- Camshaft
- Turbocharger shafts
- Bone screws
- Worm gears
- Balance shafts
- Hydraulic parts
- Valves (diesel engine)
- and much more



For more information, please visit our website: www.mahr.com

MarShaft SCOPE 600 plus 3D

Optical and tactile measuring system

DESCRIPTION

As a specialist in camshaft applications and more recently (optional) in straight and helical cylinder gears, Mahr now offers a completely new measuring technique with the new MarShaft SCOPE 600 plus 3D measuring station: The combination of optical and tactile sensors enables 3D functionality for the first time and thus a complete inspection of the workpiece in one setup. To this end, Mahr has enhanced its already very successful MarShaft SCOPE 750 plus measuring station. It now has a new 2D probe system, a motorized tailstock and calibration for the linear axes. The matrix camera optically measures features such as diameters, lengths, radii, form, position features, cam angles and the cam pitch in just a few seconds. The additional 2D probe records features that cannot be measured optically: concave cam profile, all standard gear parameters on cylindrical gears, axial runouts, reference elements in an axial direction, such as axial grooves. The tactile and optical system are calibrated in one coordinate system. The measuring station uses the MarWin software platform to deliver complete 3D functionality.



TECHNICAL DATA

| Order no. | 5361522 |
|-----------------------------------|---|
| Measuring range length (Z) (mm) | 600 |
| Measuring range diameter (X) (mm) | 120 |
| Workpiece weight (max.) in kg | 15 |
| Length/diameter resolution (mm) | 0.01 to 0.0001 |
| Angle resolution (°) | 0.01 to 0.0001 |
| Length error limit (Z) (µm) | (2 + L/125) L in mm (at 20°C ± 1°C on reference standard) |
| Diameter error limit (X) (µm) | (1.0 + L/125) L in mm (at 20°C ± 1°C on reference standard) |
| Drives | Servo motors |
| Lens | Telecentric precision lens high-resolution CCD array |

Performance features at a glance:

- Complete measurement of camshafts, including the cam angle and all standard cam contours
- Measurement of the gears on cylindrical gears
- Measurement of contour elements
- Drive pins not used
- Direct measurement of references (e.g. 2-flat or feather key groove)
- Measurement of feather key grooves
- Measurement of blind holes
- 100% 3D function using new 2D probe
- Additional Y measurement axis
- Special calibration of linear axes (Z-X-Y)
- MarShaft Professional
- Manual control panel

Options:

- Barcode scanner
- Signal light (red, yellow, green)
- Coated tip (no driver required)
- Vibration isolation system
- Temperature compensation
- Thread measurement
- Turbocharger shaft measurement

APPLICATIONS

- Complete measurement of camshafts
- Complete measurement of gear shafts

Typical workpieces

- Camshaft
- Gear shafts
- Eccentric shafts
- Shafts with keyways or blind boreholes



For more information, please visit our website: www.mahr.com

ACCESSORIES

| Order no. | Description |
|-----------|--|
| 5361142 | DMC scanner set For MarShaft SCOPE <i>plus</i> (all models), incl. USB cable and holder |
| 5361140 | Signal lamp red/yellow/green To display the status of the measuring machine, Red=error, Yellow=measurement/calibration is running, Green=measuring machine is finished/available, incl. control unit for operating the signal lamps |
| 5362502 | Standing desk Sturdy, aluminum colored frame, screen consists of perforated plate, plate can be adjusted by tilting, Measurements (W/D/H): 70/50/109-126 cm |
| 5361804 | Keyboard with mouse / wireless German |
| 5361805 | English |
| 5361806 | Spanish |
| 5361807 | French |
| 5361808 | Hungarian |
| 5361514 | Tactile measuring unit with additional y-measuring axis (measuring path 60 mm) Version with 1D dial test probe, two friction clutches provide collision protection, measuring anvil with carbide ball - Ø 2 mm, 90° swivel device enables axial (axial run-out) and radial (roundness and radial run-out) measurements |
| 5361515 | Version with 2D form measuring probe (2 coordinates) Measuring range +/- 300 µm, measuring force at 100 µm deflection = 0.2 - 0.3 mN, protected from collision by probe arm magnet holder, default probe arm order no. 5367977 included in delivery, In addition to form and position tolerances, the 2D function also allows the scanning of radial bores, for example. In conjunction with MarShaft Professional, highly precise form measurements are possible. |
| 5367977 | Probe arm set default for probe system 1320/2B (MarShaft SCOPE 600/850 <i>plus</i> 3D) Functional length = 72 mm, carbide shaft 16 mm, ruby ball 0 = 2 mm |
| 5367978 | Probe arm set camshaft for probe system 1320/2B (MarShaft SCOPE 600/850 <i>plus</i> 3D) Functional lengths: Stylus 1 = 73 mm, stylus 2 = 75 mm, stylus 3 = 95 mm, 3 ruby balls 0 = 2 mm |
| 5367979 | Probe arm set FL83 for probe system 1320/2B MarShaft SCOPE 600/850 <i>plus</i> 3D) Functional length = 83 mm, carbide shaft = 25.3 mm, ruby ball 0 = 2 mm |
| 5367980 | Probe arm set FL95 for probe system 1320/2B (MarShaft SCOPE 600/850 <i>plus</i> 3D) Functional lengths: Stylus 1 = 75 mm, stylus 2 = 95 mm, 2 ruby balls 0 = 2 mm |
| 5367981 | Probe arm set FL72 for probe system 1320/2B (MarShaft SCOPE 600/850 <i>plus</i> 3D) Functional length = 72 mm, carbide shaft = 16 mm, ruby ball 0 = 2 mm |
| 5367982 | Probe arm set FL72 for probe system 1320/2B (MarShaft SCOPE 600/850 <i>plus</i> 3D) Functional length = 72 mm, carbide shaft = 12 mm, ruby ball 0 = 1 mm |

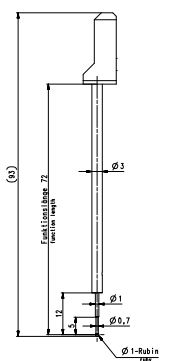
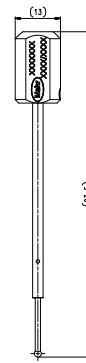
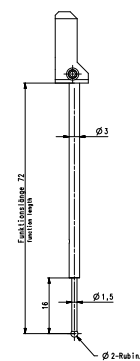
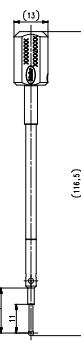
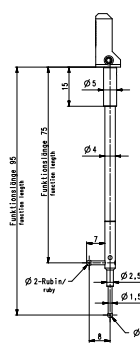
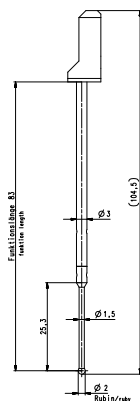
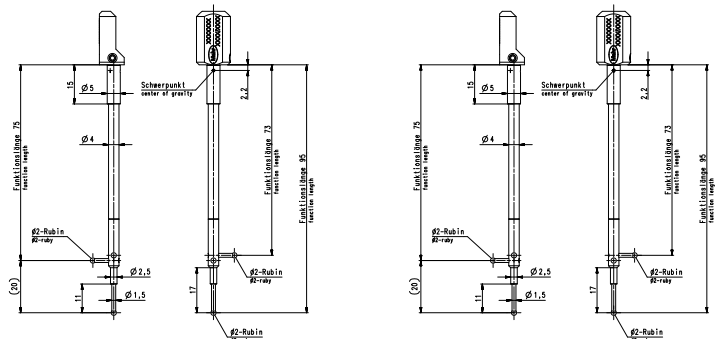

ACCESSORIES

| Order no. | Description |
|-----------|--|
| 5361513 | Manual control panel MarShaft SCOPE 350/750/1000 (MarShaft SCOPE 650 <i>plus</i> 3D series) The MarShaft Scope <i>plus</i> can also be operated using a manual control panel. The manual control panel consists of a keypad with 14 keys for controlling the machine axes, quick program start keys, an emergency stop key and a release key. |
| 5361552 | Temperature compensation for MarShaft SCOPE 350/750/1000 Temperature compensation is an approximate way of correcting temperature-based measurement errors. The process compensates firstly for deviations in the measuring machine and calibration elements and secondly for length expansion in the testpiece. Temperature sensors that record the machine temperature are located at important machine positions. The control software corrects the measuring machine to a reference temperature. A separate temperature sensor is available for measuring the temperature of the testpiece. |
| 5361112 | Centering tip 60° Ø 2-15 mm, height = 35 mm (lower end face to the upper edge of the tip) 2 units included in delivery of the MarShaft SCOPE 250 <i>plus</i> |
| 5361223 | centering tip 60° Ø 2-44 mm, height = 46 mm, (lower end face to upper edge of the tip) 2 units included in the scope of delivery of the MarShaft Scope 350/600/750/1000 <i>plus</i> |
| 5361105 | Centering tip 60° Ø 3-15 mm, height = 25 mm, (lower end face to upper edge of the tip) |
| 5361106 | Centering tip 60° Ø 2-35 mm, height = 44 mm, (lower end face to upper edge of the tip) |
| 9056631 | Centering tip 60° Ø 2-19 mm, height = 46 mm, (lower end face to upper edge of the tip), Carbidor coated (from Ø 36 mm) |
| 9052904 | Centering tip 60° Ø 2-35 mm, height = 46 mm, calibration collar, Carbidor coated, height = 56 mm (lower end face to upper edge of the tip), Carbidor coated (from Ø 36 mm), factory calibration of the calibration collar on request |
| 5361107 | Centering tip 120° Ø 8-40 mm |
| 5361104 | Centering tip 90° Ø 6-20 mm |
| 5360539 | Calibrating shaft for MarShaft SCOPE 250 <i>plus</i> Ø 5 - Ø 45 mm, length = 250 mm, diameter graduation: 5 mm, 16 lengths from 5 mm to 185.5 mm, 1 width across flats 8 mm, incl. DAkkS - calibration certificate, wooden case, delivery does not include measuring program |
| 5360532 | Calibrating shaft for MarShaft SCOPE 350 <i>plus</i> Ø 25 - 110 mm, length = 300 mm, graduation of the diameter: 25 mm, 40 mm, 60 mm, 80 mm, 110 mm, graduation of the lengths: 37 mm, 52 mm, 86 mm, 101 mm, 165 mm, 238 mm, 266 mm, 280 mm, 300 mm incl. DAkkS certificate, wooden case, scope of delivery does not include measuring program |
| 5360531 | Calibrating shaft for MarShaft SCOPE 600/750/850/1000 <i>plus</i> Ø 25 - 110 mm, length = 583 mm, graduation of diameter: 25 mm, 40 mm, 60 mm, 80 mm, 110 mm, graduation of the lengths: 37 mm, 52 mm, 112 mm, 127 mm, 165 mm, 201 mm, 216 mm, 312 mm, 419 mm, 521 mm, 549 mm, 563 mm, 583 mm, DAkkS certificate, wooden case, delivery without measuring program |

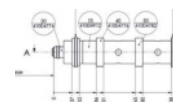

MarShaft Software EasyShaft

DESCRIPTION

- **MarWin EasyShaft software** is the measuring, control and evaluation system for the MarShaft SCOPE plus. It offers precision measurement of diameters, lengths, contour features and form and position tolerances in accordance with standards, along with many new evaluation and documentation options, all with a well-laid-out, intuitive user interface.
- The software runs entirely under the familiar Windows® operating system. The user interface is compatible with other Windows applications, reducing the familiarization time substantially. All Windows-compatible printers can be used for record output.

Performance features at a glance:

The familiar Windows user interface makes for a short learning curve

- The user interface is used as standard across all Mahr products (e.g. EasyForm or Contour 1)
- Clear, windows-based layout
- User-friendly, 100% touchscreen functionality
- Predefined macros for easy programming (e.g. diameter measurement at a mouse click)
- Many functions can be selected directly via obvious icons
- Touchscreen-controllable machine axes
- The live image from the matrix camera is permanently displayed during measurement, i.e. direct visual assessment of the workpiece condition (e.g. soiling) even during measurement
- For individual and serial measurements: the ideal operating strategy for every task
- User-friendly, state-of-the-art measuring program management
- Time-optimized measuring program sequence (shortest measuring times)
- Meaningful measuring records – in black-and-white or color – output to all Windows® printers
- Future-proof investment, runs under Windows 10
- Optional data export to statistics programs extends the range of functions of the EasyShaft software

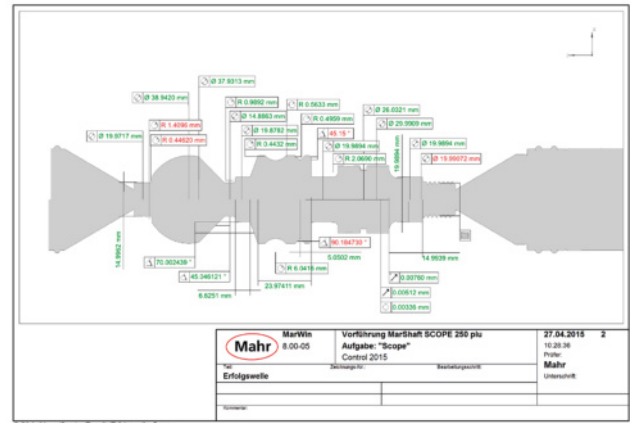
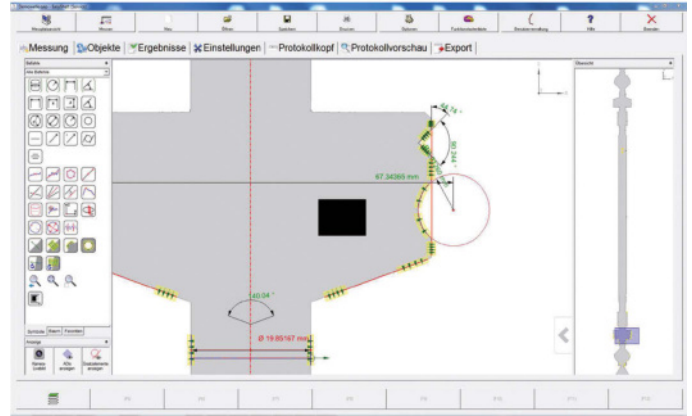

For more information, please visit our website: www.mahr.com

OPTIONS

EasyShaft program window

- The EasyShaft software gives you full control over the MarShaft SCOPE. The touchscreen gives you direct access to positioning, programming, measurement and documentation. The excellent, simple user interface helps you keep track of everything you need to know.
- Many functions, such as loading measuring results or adding feature measurements, can be selected simply by clicking an icon.

EasyShaft commands

- The clearly laid-out command bar contains all the commands required for measuring and evaluating features.
- Macros (composed sequences of evaluation actions, e.g. diameter, radius, distance or angle)
- Features which can be calculated (e.g. direct distance, distance in X and Z, angle, angle sector, radius, roundness, straightness, radial run-out, axial run-out, cylindricity, symmetry)
- Substitute elements which can be calculated (e.g. point, line, circle, point on straight line, intersection point, symmetry straight line, parallel straight line, extreme point, C-reference)

Display palette (touchscreen control of machine axes)

- Used to show or hide the display palette
- Used to select the zoom range
- Joystick for the C-axis
- Joystick for the X- and Z-axis
- Zoom in incrementally
- Zoom in or out continuously
- Zoom out incrementally

| № | Feature | Value | Unit | Status |
|---|----------|--------|------|--------|
| 1 | DIAMETER | 10.000 | mm | OK |
| 2 | RADIUS | 5.000 | mm | OK |
| 3 | DISTANCE | 10.000 | mm | OK |
| 4 | ANGLE | 90.000 | deg | OK |
| 5 | ... | ... | ... | ... |



For more information, please visit our website: www.mahr.com

Engineered Solutions | Customer-specific metrology

As modern production techniques develop, bringing with them growing demands in terms of flexibility and quality, conventional metrology faces new challenges. With Engineered Solutions, Mahr can offer you tailor-made solutions that take account of specific environmental conditions and requirements relating to handling, reliability and speed. Measuring solutions that are as individual as your measuring task: For us your requirements are the benchmark.

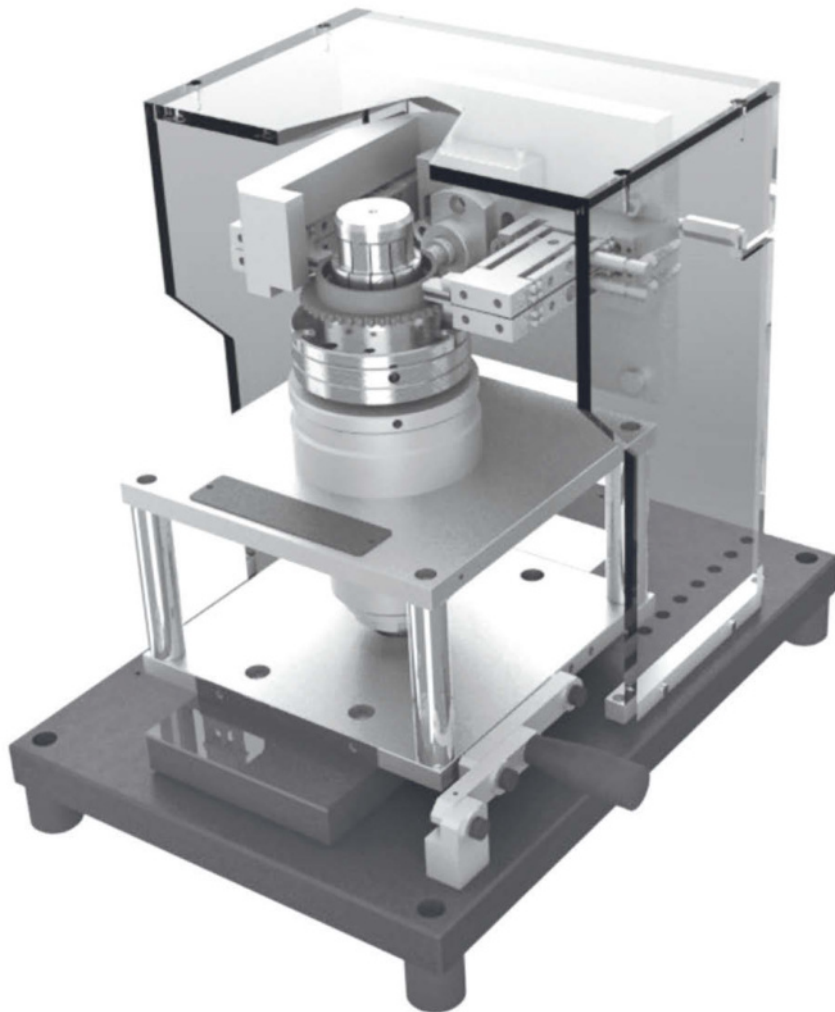

| | |
|--|------------|
| Engineered Solutions Customized measuring stations | 640 |
| Engineered Solutions Dimensional solutions | 641 |
| Engineered Solutions Contour and surface solutions | 642 |
| Engineered Solutions Automated solutions | 643 |
| Engineered Solutions MarSurf Engineered | 644 |



The latest information about Engineered Solutions can be found on our website:
www.mahr.com

Customized measuring stations

Complex measuring tasks, striving for maximum efficiency, prompt measuring results on site or the desire for maximum ease of use sometimes require solutions that have been individually designed with these requirements in mind. With Engineered Solutions, Mahr consolidates its extensive product expertise to design tailor-made measuring stations for customers around the world.

We are typically required to:

- Measure directly in production
- Come up with measurements that are easy for on-site personnel to carry out
- Provide measuring results within a few seconds
- Reliably complete complex and demanding measuring tasks
- Simplify measuring tasks that occur on a daily basis
- Have 100% inline control – solutions for integration in the production line
- Have measuring results that can be documented and traced

What challenge are you facing?

There are many reasons why an individual measuring solution may be required. There is generally one problem that cannot be solved at all or is very labor-intensive to solve with the usual standard measuring machines. We solve that problem.

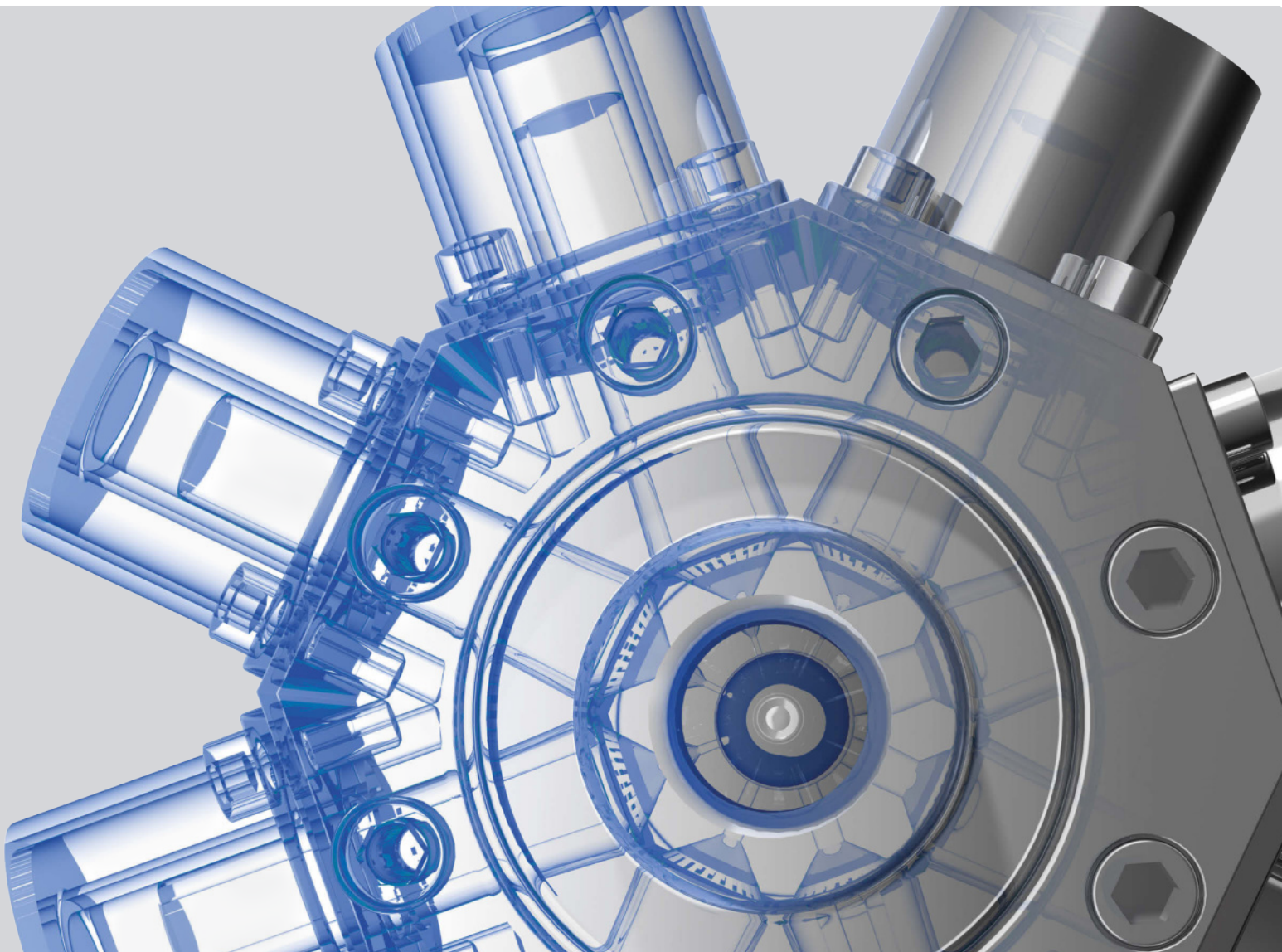

Clever measuring devices, excellent results

Dimensional solutions from Mahr Engineered Solutions



Manual solutions

Manual loading and measurement

- Measure directly in production
- Easy to handle
- Measuring result is available within a few seconds
- Reliable and safe measurements carried out by workshop personnel



Semi-automatic solutions

Manual loading and fully automatic measurement

- Dynamic measurements
- Complex measuring tasks
- Increased efficiency through automation of measuring sequences



Fully automatic machines

Fully automatic inline measurements

- Measuring cell for integration in the production line
- Automatic workpiece recognition and measuring program selection
- Workpiece feeding and alignment
- Workpiece classification



OEM solutions

Measuring modules for inline integration

- Integration of measuring heads in production and assembly lines
- Cooperation with integrators according to customer requirements
- Simple connection and integration
- High-precision metrology from the expert as part of a complete system

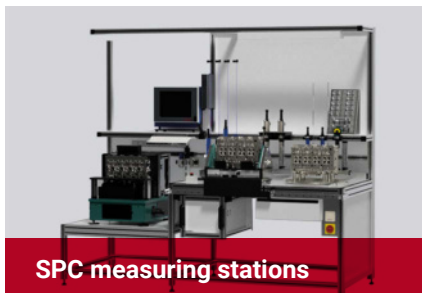

SPC measuring stations

Turnkey solutions for different measuring tasks

- Complete SPC measuring stations with a wide variety of measuring equipment for handling all pending measuring tasks in a manufacturing process
- Complete metrological equipment for production lines and/or workshops

Radius, angle, roughness – or chamfer?

Contour and surface solutions from Mahr Engineered Solutions



Manual auxiliary devices

Quick and easy help in your everyday work

- Elimination of time-consuming setup and alignment of workpieces
- Easy measurement of complex or difficult measuring tasks
- Error reduction through avoidance of incorrect operation



Mobile solutions

The measuring equipment comes to the workpiece

- Measurement directly at the production site
- Measurement directly in the production line, without ejection of the workpiece
- Surface measuring task as part of an SPC measuring station



Manual measuring stations

Positioning and recurring measuring tasks made easy

- Targeted and easy processing of individual measuring tasks
- Easy handling of large and heavy workpieces
- Efficiently process recurring measuring tasks, e.g. work sequence plans

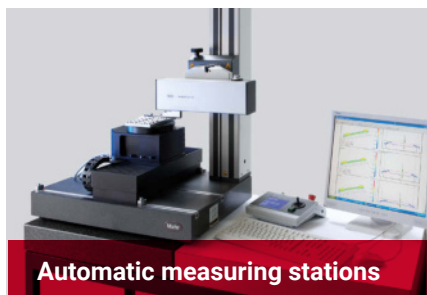

Automatic measuring stations

Automated measuring sequences without tying up personnel

- No operator influence on measuring results
- No staff need to be involved during measurement
- Automation and high-precision metrology combined across the entire measurement circuit



Fully autonomous measuring stations

Insert workpiece, start measurement and get result

- Fully autonomous inline processing of numerous and complex measuring tasks without staff involvement
- All-in-one measuring station: Automatic workpiece recognition and selection of measuring program, probe arm, etc.

Stand-alone machines – automated solutions



Autonomous measuring stations

Measurement without staff involvement

- Fully autonomous processing of multiple and complex measuring tasks
- Combination of several measuring sensors into one measuring station
- Automated measuring room
- Operation without metrology personnel

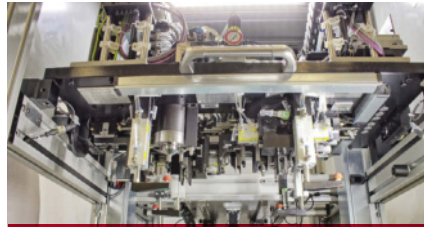

Inline solutions

Measuring stations for integration

- Complete measuring stations with workpiece feeding and output
- Automated workpiece handling in the measuring station
- Automatic workpiece recognition and measuring program selection
- Fully automatic measurement



Complete inline solutions

Measuring stations with peripherals

- Workpiece feeding and alignment
- Workpiece classification
- Laser marking of the workpiece
- Bulk material feeder
- Inspection tasks such as crack detection

For more information,
please visit our website

info-engineered@mahr.com



MarSurf Engineered – customized solutions

Starting with individual workpiece holders right down to fully automatic measuring stations, Engineered Solutions in the MarSurf sector make it possible to simplify surface measurement. Depending on customer requirements, the existing solution portfolio may be used or a new, customized design developed.

Mobile solutions

The measuring equipment comes to the workpiece

- Measure large and heavy workpieces directly at the production site
- Measurement in the production line, without ejection of the workpiece
- Surface measuring task as part of an SPC measuring station



Manual measuring stations

Positioning and recurring measuring tasks made easy

- Targeted & easy processing of individual measuring tasks
- Easy handling of large and heavy workpieces
- Efficiently process recurring measuring tasks, e.g. work sequence plans



The measuring stations displayed are a small selection of previously planned solutions. More information about Engineered Solutions at www.mahr.com

Automatic measuring stations

Automated measuring sequences without tying up personnel

- No operator influence on measuring results
- No staff need to be involved during measurement, which leads to increased efficiency and cost savings
- Automation and highly accurate metrology combined across the entire measurement circuit



Fully autonomous measuring stations

Insert workpiece, start measurement and get result

- Fully autonomous processing of numerous & complex measuring tasks without staff involvement
- Increased efficiency and cost reduction thanks to automatic workpiece recognition, easy selection of measuring programs etc.
- High-quality design for 24/7 operation in production
- Operation by workshop personnel



The right software for the machine

MarSurf Engineered measuring stations use specially developed, intelligent software solutions

- Measuring program creation targets the features to be measured
- No programming knowledge required
- Process-optimized measuring programs
- Simple duplication of measuring programs on structurally identical machines

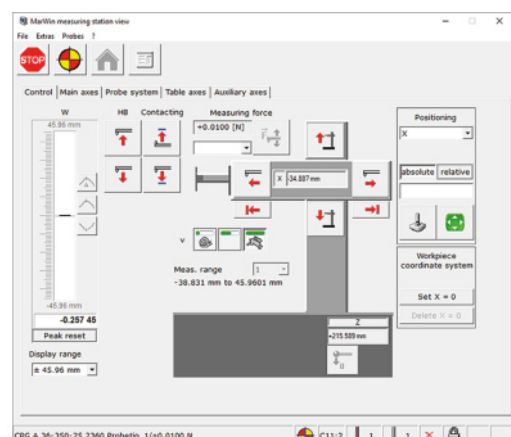

Mahr | Service

Mahr offers a worldwide service network, through its many branches and agencies. In addition to product-related services, we have additional resources available from some of our sites. Mahr is happy to help with any of your metrology questions, no matter how specific. Just ask us!



| | |
|--|------------|
| Mahr Academy | 648 |
| Application advice | 648 |
| Technical service | 649 |
| Service agreements | 649 |
| Measuring system calibration services | 650 |
| Handheld measuring tool calibration logistics | 651 |
| Gage management | 652 |
| Repair or exchange | 653 |
| Order and subcontract measurement | 654 |
| Capability testing | 655 |



The latest information about the MAHR SERVICE CENTER is available on our website:
www.mahr.com



In addition to product training, the Mahr Academy also provides technical content. We not only offer training and courses in metrology, but also in test equipment and quality inspection. Our instructors are one hundred percent in the subject and know from their own experience what it's all about.

Our topics are:

- Quality and test equipment management
- Practical application of production measurement technology
- New standards DIN / ISO / GPS
- AUKOM courses (AUKOM Level 1 - 3, AUKOM Measurement Technician, AUKOM Update, AUKOM Form and Position, AUKOM Management Workshop)
- Webinars and eLearnings

Practical relevance

Experience shows: Practice demands practice! That is why practical application is the focus of every Mahr offer.

Teamwork

Learning is effective in a group. Here you can exchange ideas and benefit from the experiences of the other participants.

Small groups

Due to small groups at our seminars, everyone gets a chance to speak and all questions are answered.

On site and online

All seminars can be booked on-site, online or as hybrid events – so you retain full flexibility.



Do you need help with designing solutions for metrological tasks? Do you need to create measuring programs for complex workpieces? Do your users need some basic product training?

Take advantage of the services offered by our application engineering specialists, with their extensive knowledge and many years of experience in dimensional metrology.

Our application engineering and technical service specialists also offer:

- Sample measurements
- Help with commissioning equipment
- Program creation
- Product training
- Measuring equipment capability testing
- User training

For more information, please visit our website: www.mahr.com

Technical service



Mahr quality guidelines set high standards in which **Mahr measuring instruments** are developed and manufactured, using the very latest technology available. This guarantees that consistently, all **Mahr measuring instruments** are of the highest quality.

To assure that your machine/measuring station receives the best possible care, Mahr operates an efficient worldwide service organization. The **Mahr Service Organization**, run by trained specialists, is equipped with cutting edge tools and instruments, many of which have been specially developed, and stocks an extensive range of spare parts.

Mahr works according to progressive, tried-and-tested guidelines and offers a range of complementary services. To ensure the best results from your **Mahr measuring equipment** at all times, we recommend you use only the services offered by the **Mahr Service Organization**. This is the only way of ensuring that only **original Mahr spare parts** and servicing procedures are used, reflecting the stringent **Mahr quality standard**.



You will find the right contact for your service request under:

www.metrology.mahr.com/en-int/service/mahr-service/service-contacts

Service agreements

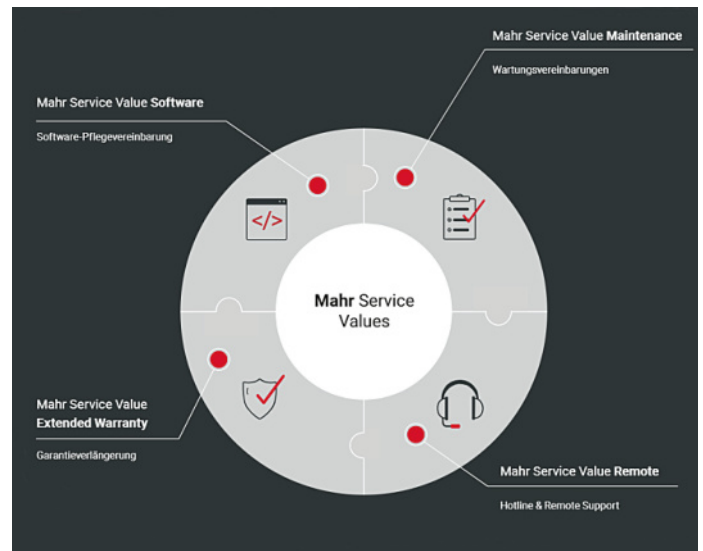

Our service agreements – packages with added value. Whether it's day-to-day business or an exceptional situation: when you call on our service, you want speedy, competent support – without having to worry about the costs. That's exactly what Mahr Service Values are for: our agreements for maintenance, software support, warranty extensions as well as hotline and remote support.

Conveniently secure the right service for your needs with Mahr Service Values - and retain full control over your budget. Depending on the package, we also guarantee you shorter response times or prioritized appointments. You can also put together your own individual service package according to the modular principle. Try it out!

Measuring system calibration services

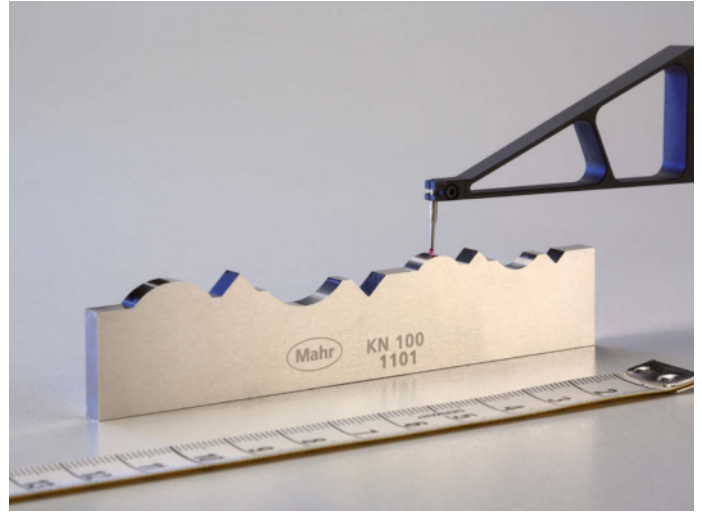

Mahr runs laboratories for various instruments and instrument sizes in the field of length metrology. These laboratories ensure high dimensional accuracy and very low measurement uncertainties. In principle, all measuring equipment can be calibrated. Specific core competencies are available for the following calibration services:

- Gage calibration (length) *
- Parallel gage blocks *
- Setting rings / setting plug gages / setting disks / pin gages *
- Geometry and roughness standards *
- Optical flats
- Inductive probes with/without display unit *
- Thread plug gages / thread ring gages *
- Incremental probes *
- Vertical length measuring devices / height measuring units *
- Calipers / outside micrometers *
- Dial gages / dial comparators / dial test indicators *
- Setting standards *
- Magnification standards (flicks) *
- Contour standards *
- Stylus instruments / roughness and contour measuring instruments *
- Testing cylinders / cylinder squares *
- Roundness standards *
- Length measuring devices *
- Multi-shaft standards *
- Dial comparator and dial gage testers *
- Super-fine roughness standards *
- Custom objects on request
- Depth measurement standards *

* Calibrations with officially recognized calibration certificates according to national and international standards, e.g. DAkkS/DKD (German Calibration Service).

DAkkS (German Calibration Service) is a signatory of the multilateral agreement by the European cooperation for Accreditation (EA) and the International Laboratory Accreditation Cooperation (ILAC) concerning the mutual recognition of calibration certificates.

Your Mahr contact will provide you with information on national and international recognition, e.g., as part of the multilateral agreements www.european-accreditation.org and www.ilac.org



Deutsche
Akkreditierungsstelle
D-K-15074-01-00



For more information, please visit our website: www.mahr.com

Handheld measuring tool calibration

Would you like to have your handheld measuring equipment calibrated by **Mahr**?

Mahr offers calibration also for **non-Mahr products**.



All manufacturers and brands

Our laboratories are accredited and work independently of manufacturers. The following applies to hand-held measuring instruments: No matter what brand your measuring equipment is, we calibrate it – for service from one source.



For more information, please visit our website: www.mahr.com

Gage management

Are you looking to cut your annual calibration costs and to optimize processes for managing and maintaining your gages? Our Service team can help! And that's not all. With the latest Mahr software you can reduce the time you spend on gage management by up to 70%.

Mahr can optimize your gage inventories

Gage management tends to be organized on an individual basis, with companies having very specific requirements. That is why we analyze your needs in detail and work with you to establish the right solutions. Services we can offer in this area include the following:

Record gage inventories

- Help with recording gages, measuring equipment and other tools
- Categorizing into gages and tools
- Defining appropriate inspection intervals

Manage gage inventories

- Organizing simple internal procedures for calibrating, servicing and maintaining gage inventories
- Software solution for gage management
- Measuring instruments and software solution for in-house calibration
- Logistics solutions (e.g., collection service)
- Staff training

Optimizing gage inventories

- **Selecting suitable gages**
- Evaluating and improving test processes
- "Decluttering" gage inventories

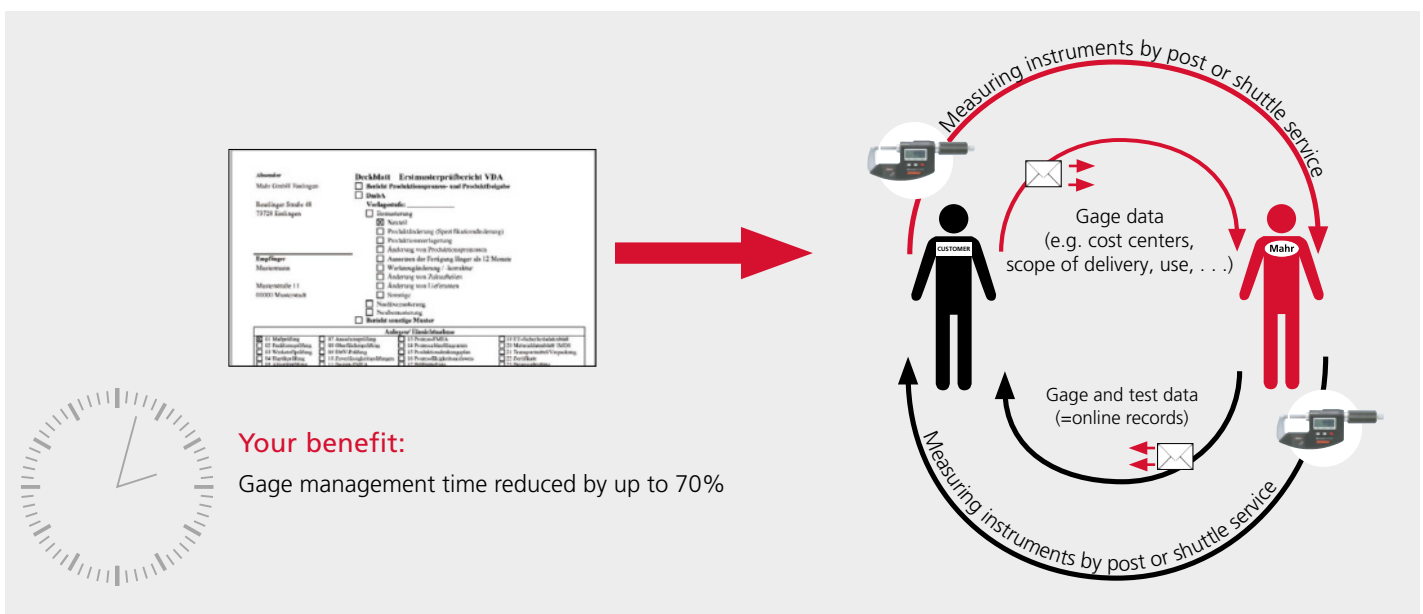

For more information, please visit our website: www.mahr.com

Repair or exchange

Replacement and rental service

Replace instead of repair - this is a simple solution for lots of measuring equipment and small devices. You receive a refurbished device or a corresponding component as a replacement for the defective technology quickly and easily. In this way you can keep downtimes to a minimum and get a 12-month warranty on the replacement unit.

Refurbished equipment & components as replacements (examples):

- Outside micrometers and digital calipers
- Indicating measuring instruments from the Marameter product group
- Mobile roughness measuring instruments, e.g. MarSurf PS 10 or MarSurf M 300
- Surface drive units and probe systems
- Probe arms for surface and form measurement

The choice is yours:

Exchange (Mahr instruments)

If you send in your faulty device you will receive in return a refurbished instrument from our exchange pool, repainted if necessary. We will also engrave your ID number on it if you wish.

Your benefit: Your downtime is kept to a minimum.

Repair

Of course you can also have your own device repaired. When we repair an instrument we fix any functional defects, rework the measuring surfaces and put right any cosmetic damage. The cost of replacement parts is already included in the repair price in this case too.

Your benefit: Thanks to our expertise as the original manufacturer, you have the certainty that after being repaired, your instrument will have the same specification and accuracy as a new unit.

Repair regardless of manufacturer

We can repair leading brands of length measuring instruments.

Your benefit: You have just one contact for all your instrument repairs

Refurbishment (Mahr instruments)

With refurbished instruments we not only fix any faults but also replace worn-out wear parts as a precaution and put right any cosmetic damage. This restores the instrument's metrological capabilities to those of a new device.

Your benefit: When your instrument is returned, its metrological capabilities are equivalent to those of a new device.

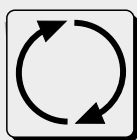

EXCHANGE

Delivery time: approximately 3 working days



REPAIR

Delivery time: depends on instrument

For more information, please visit our website: www.mahr.com

Subcontract measurement services from Mahr

Subcontract measurement and capability testing:

We measure what your measuring devices cannot.

Your benefit: You save money by not having to purchase expensive new equipment.

We help when your measuring capacities are overloaded.

Your benefit: You avoid the need for additional staff and machines.

We test the capability of your measuring systems and the suitability of your equipment for your applications.

Your benefit: When tolerances are tight, you can be sure you are using the right equipment.

Mahr offers the following subcontract measurement services:

1. Measurements on 3D coordinate measuring machines by one of the following methods:
 - a) tactile,
 - b) optical (non-contact), or
 - c) by 3D laser scanning
2. Form and position measurements
3. Roughness and surface
4. Contour measurement
5. Initial sample inspection according to the regulations of the Association of the German Automotive Industry (VDA) and other regulations

Measuring records

After sample inspection of your workpiece you will receive a professional measuring record from us, to which you can refer if any inspections should be required (e.g., in the event of production errors).

Digitization

We can also take care of digitization tasks for you, i.e., we can create CAD data sets to be read into production machines. In reverse engineering procedures, 3D laser scanners generate an exact map of a workpiece in the form of high-resolution point clouds. These point clouds then form the basis for the CAD data set that is created from it.

For more information, please visit our website: www.mahr.com

Capability testing

Mahr tests the capability of your measuring systems:

Are your measuring machines and measuring equipment accurate enough to meet the constantly increasing demands in relation to tolerated deviation?

When workpiece tolerance demands are high, measuring systems are often operating at the limit of their capabilities. Mahr can check whether your measuring machines and equipment are suitable for the tasks at hand. There are two possible methods of capability testing. The effects of various factors which lead to inaccurate measuring results can be more precisely limited in this way.

Method 1:

This method determines the general capabilities of the devices. This is usually carried out in our laboratory, but in exceptional cases it can also be done in your measuring room.

Method 2:

This method determines the influence of the operator on the measuring results. Here we test the devices at your premises under normal operating conditions. We also involve the staff who will be working with the devices later on. As with calibration, a certificate and/or record is issued after the capabilities of the measuring systems have been determined.

Method 3:

Here the test is carried out using automatic measuring equipment. The aim is to exclude the operator influence that is intentionally assessed with method 2. This method is usually carried out on 25 workpieces in two test cycles.

We can conduct these procedures either at our premises as a pre-inspection or at your site in the form of a final inspection. In this way you can be sure of achieving a high level of measuring accuracy on your own premises too. The specified measuring conditions must of course be adhered to.

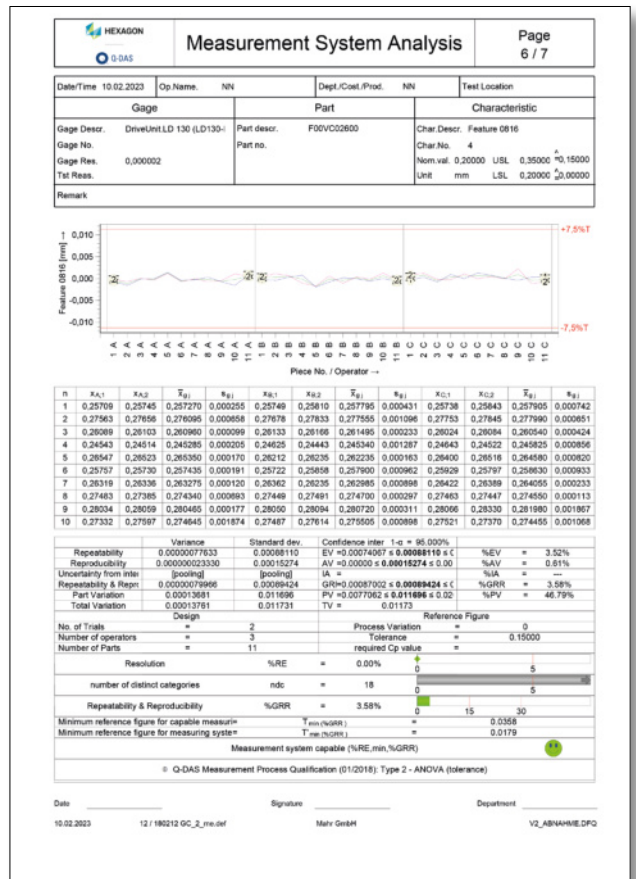

For more information, please visit our website: www.mahr.com

Mahr | Numerical Index

| Instrument | Page | Instrument | Page | Instrument | Page |
|------------|----------|-------------|----------|------------|---------|
| 1000 A | 209 | 16 EWR-SM | 47 | 26I | 170 |
| 1000 B | 209 | 16 EWR-V | 38 | 26IM-RC | 170 |
| 1002 | 206 | 16 EWR-VS | 48 | 26K | 168 |
| 1002 T | 206 | 16 EWri | 24 | 26K-RC | 168 |
| 1002 Z | 211 | 16 EWri-AA | 51 | 26Q | 168 |
| 1002 ZT | 211 | 16 EWri-AI | 53 | 26Q-RC | 168 |
| 1003 | 206, 208 | 16 EWri-AR | 44 | 27I | 168 |
| 1003 T | 206 | 16 EWri-BA | 49 | 27I-RC | 168 |
| 1003 XL | 207 | 16 EWri-C | 42 | 27O | 168 |
| 1003 XLT | 207 | 16 EWri-H | 43 | 27O-RC | 168 |
| 1003 Z | 211 | 16 EWri-LI | 55 | 28IM | 170 |
| 1003 ZT | 211 | 16 EWri-NA | 45 | 28IM-RC | 170 |
| 1004 | 207 | 16 EWri-RW | 54 | 28IN | 168 |
| 1004 T | 207 | 16 EWri-S | 46 | 28IN-RC | 168 |
| 1004 Z | 211 | 16 EWri-SA | 50 | 28IQN | 176 |
| 1004 ZT | 211 | 16 EWri-SI | 52 | 28ISN | 176 |
| 1010 | 210 | 16 EWri-SM | 47 | 29I | 176 |
| 1010 T | 210 | 16 EWri-V | 36 | 30 EWR | 56 |
| 1010 Z | 211 | 16 EWri-VS | 48 | 30 EWR-D | 58 |
| 1010 ZT | 211 | 16 EWd | 17 | 30 EWR-N | 59 |
| 107 G | 284–286 | 16 EXr | 16 | 30 EWri | 56–57 |
| 1075 R | 132 | 16 EXu | 15 | 30 EWri-D | 58 |
| 1086 R | 136–137 | 16 FN | 30 | 30 EWri-N | 59 |
| 1086 R-HR | 139 | 16 GN | 30 | 300P-1 | 305 |
| 1086 Ri | 133–134 | 16 U | 29 | 300P-1M | 306 |
| 1086 WR | 138 | 18 ESA | 34 | 300P-2 | 305 |
| 1086 WRi | 135 | 18 EWR | 33 | 300P-2M | 306 |
| 1086 ZR | 136 | 18 EWR-V | 40 | 300P-3 | 305 |
| 1087 BR | 144 | 18 EWri | 32 | 300P-3M | 306 |
| 1087 BRi | 143 | 18 NA | 35 | 300P-4 | 305 |
| 1087 R | 141 | 2000 USB | 83 | 300P-4M | 306 |
| 1087 R-HR | 142 | | 15 | 300P-5 | 305 |
| 1087 Ri | 140 | 2000 W | 188 | 300P-5M | 306 |
| 109 P | 579 | 2000 Wi | 188 | 300P-6 | 305 |
| 109 PS | 579 | 2000 d | 17 | 300P-6M | 306 |
| 109 Pst | 579 | 2000 r | 16 | 300P-7 | 305 |
| 12I | 164 | 2001 W | 190 | 300P-7M | 306 |
| 12I-RC | 164 | 2001 Wi | 190, 192 | 300P-8 | 305 |
| 12Q | 164 | 220 Set 2/1 | 578 | 300P-9 | 305 |
| 12Q-RC | 164 | 220 Set 2/2 | 578 | 301 P | 313 |
| 1301 | 248 | 220 Set 2/3 | 578 | 301P-1 | 312 |
| 1303 | 248 | 22I | 168 | 301P-2 | 312 |
| 1304 K | 249 | 22IN-RC | 168 | 301P-3 | 312 |
| 130B-16 | 493 | 22P-10M | 322 | 301P-4 | 312 |
| 130B-24 | 493 | 22P-11 | 321 | 301P-5 | 312 |
| 1318 | 250 | 22P-15 | 321 | 301P-6 | 312 |
| 1340 | 251 | 22P-15M | 322 | 301P-7 | 312 |
| 16 DN | 31 | 22P-20 | 321 | 301P-8 | 312 |
| 16 ER | 27–28 | 22P-20M | 322 | 301P-9 | 312 |
| 16 ESv | 16 | 22QN | 168 | 32I | 172 |
| 16 EWR | 25–26 | 22QN-RC | 168 | 32I-RC | 172 |
| 16 EWR-AA | 51 | 23I | 170 | 32Q | 172 |
| 16 EWR-AI | 53 | 23IM-RC | 170 | 32Q-RC | 172 |
| 16 EWR-AR | 44 | 23K | 168 | 355 E | 467–469 |
| 16 EWR-BA | 49 | 23K-RC | 168 | 36B-10 | 435 |
| 16 EWR-C | 42 | 23Q | 168 | 36B-10-VT | 436 |
| 16 EWR-H | 43 | 23Q-RC | 168 | 36B-19 | 438 |
| 16 EWR-LI | 55 | 23W | 168 | 36B-19M | 439 |
| 16 EWR-NA | 45 | 23W-RC | 168 | 36B-20 | 435 |
| 16 EWR-RW | 54 | 25 EWR | 411 | 36B-20-VT | 436 |
| 16 EWR-S | 46 | 25 EWri | 411 | 36B-9 | 438 |
| 16 EWR-SA | 50 | 25M | 168 | 36B-9M | 439 |
| 16 EWR-SI | 52 | 25M-RC | 168 | 390 | 470–471 |

Mahr | Numerical Index

| Instrument | Page | Instrument | Page | Instrument | Page |
|------------|-----------|---------------------|--------|-------------|------|
| 40 A | 70 | 44 EWR | 92, 94 | 810 S | 146 |
| 40 ER | 66 | 44 EWg | 98 | 810 SB | 151 |
| 40 EWR | 65, 67 | 44 F | 88 | 810 SM | 147 |
| 40 EWR-B | 83 | 45 T | 101 | 810 SRM | 147 |
| 40 EWR-K | 87 | 57B-11 | 330 | 810 SV | 146 |
| 40 EWR-L | 69 | 57B-11M | 331 | 810 SW | 149 |
| 40 EWR-R | 85 | 57B-12 | 330 | 814 G | 487 |
| 40 EWR-S | 81 | 57B-12M | 331 | 814 N | 485 |
| 40 EWR-V | 75, 77-78 | 57B-13 | 327 | 814 SR | 489 |
| 40 EWRI | 64 | 57B-13M | 328 | 815 GN | 270 |
| 40 EWRI-B | 82 | 57B-14 | 324 | 815 MA | 271 |
| 40 EWRI-K | 86 | 57B-14M | 325 | 815 MB | 272 |
| 40 EWRI-L | 68 | 57B-15 | 324 | 815 MF | 275 |
| 40 EWRI-R | 84 | 57B-15M | 325 | 815 MG | 274 |
| 40 EWRI-S | 80 | 6105 N | 263 | 815 P | 273 |
| 40 EWRI-V | 74, 76 | 6107 S | 264 | 815 XMA | 276 |
| 40 F | 71 | 6400 | 265 | 815 XMB | 276 |
| 40 FC | 71 | 800 EW | 119 | 815 XMS 285 | 276 |
| 40 SA | 70 | 800 EWL | 119 | 815 XMS 485 | 276 |
| 40 T | 72 | 800 EW _r | 16 | 815 XN | 276 |
| 40 TS | 73 | 800 EW _u | 15 | 815 XP | 276 |
| 400B-3 | 181 | 800 H | 118 | 816 CL | 477 |
| 400B-4 | 181 | 800 S | 106 | 817 CLT | 476 |
| 402 | 442 | 800 SA | 106 | 817 USB | 15 |
| 402 C | 448 | 800 SG | 106 | 818 | 287 |
| 404 | 442 | 800 SGA | 106 | 818 P | 288 |
| 404 C | 448 | 800 SGB | 107 | 818 R | 289 |
| 405 | 443 | 800 SGE | 109 | 820 FC | 278 |
| 405 C | 449 | 800 SGL | 107 | 820 FG | 279 |
| 406 | 443 | 800 SGM | 108 | 820 N | 277 |
| 406 C | 449 | 800 SL | 107 | 820 NC | 278 |
| 408 | 444 | 800 SM | 108 | 820 NG | 279 |
| 408 C | 450 | 800 SR | 106 | 821 FG | 280 |
| 409 | 444 | 800 SRM | 108 | 821 NG | 280 |
| 409 C | 450 | 800 V | 114 | 824 FT | 281 |
| 411 | 447 | 800 VGM | 115 | 824 GT | 281 |
| 412 | 446 | 801 S | 111 | 826 PC | 492 |
| 413 | 446 | 801 S1 | 111 | 827 b 14 | 282 |
| 415 | 447 | 801 SG | 111 | 827 b 16 | 282 |
| 417 C/0 | 456 | 801 SGE | 110 | 827 b 17 | 282 |
| 417 C/1 | 457 | 801 SGI | 111 | 827 b 18 | 282 |
| 417 C/2 | 458 | 801 SGL | 112 | 827 b 19 | 282 |
| 417/0 | 453 | 801 SGM | 110 | 827 b 31 | 283 |
| 417/1 | 454 | 801 SL | 112 | 827 b 32 | 283 |
| 417/2 | 455 | 801 SM | 110 | 827 b 33 | 283 |
| 418 C | 451 | 801 SR | 111 | 827 b 34 | 283 |
| 419 C | 452 | 801 SRM | 110 | 827 b 35 | 283 |
| 420 | 459 | 801 V | 117 | 827 b 36 | 283 |
| 421 | 461 | 801 VGM | 116 | 827 b 5 | 282 |
| 421 P | 462 | 802 EW | 126 | 837 | 161 |
| 421 PS | 463 | 802 NW | 127 | 838 EA | 334 |
| 424 | 460 | 803 A | 145 | 838 EI | 337 |
| 426 A | 464 | 803 AZ | 150 | 838 TA | 333 |
| 426 M | 465 | 803 S | 145 | 838 TAZ | 332 |
| 426 MS | 466 | 803 SB | 151 | 838 TI | 336 |
| 44 A | 90 | 803 SW | 149 | 838 TIZ | 335 |
| 44 AS | 91 | 805 A | 145 | 838 di (A) | 17 |
| 44 Ak | 100 | 810 A | 146 | 840 E | 302 |
| 44 Cm | 89 | 810 AG | 152 | 840 F | 294 |
| 44 Cms 1 | 89 | 810 AT | 146 | 840 FC | 295 |
| 44 Cms 2 | 89 | 810 AU | 146 | 840 FG | 298 |
| 44 Cms 3 | 89 | 810 AX | 148 | 840 FH | 296 |
| 44 Cms 4 | 89 | 810 AZ | 150 | 840 FM | 300 |

Mahr | Numerical Index

| Instrument | Page | Instrument | Page | Instrument | Page |
|------------|---------|----------------|---------|-------------|----------|
| 840 FS | 301 | 844 Ti | 422 | D5M | 172 |
| 844 A | 95 | 844 Tk | 431 | D5M-RC | 172 |
| 844 AS | 97 | 844 Tma | 419 | D6K | 172 |
| 844 Ag | 99 | 844 Tmi | 419 | D6K-RC | 172 |
| 844 D | 340 | 844 Tms | 420 | D6Q | 172 |
| 844 D-C | 343 | 844 Tp | 430 | D6Q-RC | 172 |
| 844 D-D | 349 | 844 Ts | 430 | D7I | 172 |
| 844 D-FD | 351 | 844 Tw | 418 | D7I-RC | 172 |
| 844 D-HR | 356 | 844 Tz | 426 | D7O | 172 |
| 844 D-M | 353 | 852 | 315–316 | D7O-RC | 172 |
| 844 D-R | 346 | 852 TS | 314 | D8I | 172 |
| 844 DR | 341 | 853 | 318–319 | D8I-RC | 172 |
| 844 DR-C | 344 | A1/2Q | 162 | D8IS | 176 |
| 844 DR-D | 350 | A3Q | 162 | D8IT | 176 |
| 844 DR-FD | 352 | A6Q | 162 | DK-D1 | 17 |
| 844 DR-HR | 357 | AAT–19 | 262 | DK-U1 | 15 |
| 844 DR-M | 354 | AAT–20 | 262 | DP20 | 255, 258 |
| 844 DR-R | 347 | B3K | 164 | DP50 | 255, 258 |
| 844 DR–3 | 361 | B3K-RC | 164 | DP60 | 255, 258 |
| 844 DS | 342 | B3Q | 164 | DR20 | 260 |
| 844 DS-C | 345 | B3Q-RC | 164 | DR20–3 | 261 |
| 844 DS-F | 359 | B3W | 164 | DR50 | 260 |
| 844 DS-HR | 358 | B3W-RC | 164 | DR50–3 | 261 |
| 844 DS-M | 355 | B5M | 164 | EDI–300P–1 | 303 |
| 844 DS-R | 348 | B5M-RC | 164 | EDI–300P–2 | 303 |
| 844 Dg | 362 | B6K | 164 | EDI–300P–3 | 303 |
| 844 Dg-XL | 362 | B6K-RC | 164 | EDI–300P–4 | 303 |
| 844 Dg-Z | 362 | B6Q | 164 | EDI–300P–5 | 303 |
| 844 Dga | 362 | B6Q-RC | 164 | EDI–300P–6 | 303 |
| 844 Dge | 363 | B7I | 164 | EDI–300P–7 | 303 |
| 844 Dgk | 362 | B7I-RC | 164 | EDI–300P–8 | 303 |
| 844 Dgk-Z | 362 | B7O | 164 | EDI–300P–9 | 303 |
| 844 Dt-B | 368 | B7O-RC | 164 | EDI–301P–1 | 309 |
| 844 Dt-R | 366 | B8I | 164 | EDI–301P–2 | 309 |
| 844 Dt-S | 367 | B8I-RC | 164 | EDI–301P–3 | 309 |
| 844 Dt–3 | 369 | C 1200 M | 218 | EDI–301P–4 | 309 |
| 844 Dv | 364 | C 1202 | 219 | EDI–301P–5 | 309 |
| 844 Dw | 365 | C 1750 PC | 222 | EDI–301P–6 | 309 |
| 844 D–3 | 360 | C1/2K | 168 | EDI–301P–7 | 309 |
| 844 K | 385 | C1/2K-RC | 168 | EDI–301P–8 | 309 |
| 844 KC | 382 | C1200 T | 218 | EDI–301P–9 | 309 |
| 844 Kck | 390 | C1K | 168 | EDI–36B–19 | 437 |
| 844 KM | 402 | C1K-RC | 168 | EDI–36B–9 | 437 |
| 844 KS | 388 | CD 140 | 543 | EMD–300P–1D | 304 |
| 844 KSk | 394 | CD 140 A | 542 | EMD–300P–2D | 304 |
| 844 Ke | 400 | CD 280 | 543 | EMD–300P–3D | 304 |
| 844 Kg | 397 | CIM 1000 CNC | 515 | EMD–300P–4D | 304 |
| 844 Kga | 397 | CM expert | 557 | EMD–300P–5D | 304 |
| 844 Kgz | 397 | CM mobile | 558 | EMD–300P–6D | 304 |
| 844 Kk | 392 | CM select | 559 | EMD–300P–7D | 304 |
| 844 Kt | 399 | CNC modular | 549 | EMD–300P–8D | 304 |
| 844 Kv | 398 | CP / CL select | 568 | EMD–300P–9D | 304 |
| 844 Kw | 399 | Cockpit 13 | 223 | EMD–301P–1D | 310 |
| 844 N | 404 | D1K | 172 | EMD–301P–2D | 310 |
| 844 NB | 403 | D1K-RC | 172 | EMD–301P–3D | 310 |
| 844 NH | 406 | D3K | 172 | EMD–301P–4D | 310 |
| 844 S | 432 | D3K-RC | 172 | EMD–301P–5D | 310 |
| 844 T | 416–417 | D3Q | 172 | EMD–301P–6D | 310 |
| 844 Ta | 421 | D3Q-RC | 172 | EMD–301P–7D | 310 |
| 844 Tb | 423 | D3W | 172 | EMD–301P–8D | 310 |
| 844 Tc | 424 | D3W-RC | 172 | EMD–301P–9D | 310 |
| 844 Td | 425 | D5G | 172 | EMD–36B–19D | 437 |
| 844 Te | 427–429 | D5G-RC | 172 | EMD–36B–9D | 437 |

Mahr | Numerical Index

| Instrument | Page | Instrument | Page | Instrument | Page |
|------------------------------|----------------------|---------------------------|------|---|-----------------------|
| EMD-57B-11 | 329 | N1/2O | 163 | P2010 UB | 240 |
| EMD-57B-11D | 329 | N3I | 163 | P2104 MA | 241 |
| GD 140 | 539 | N6I | 163 | P2104 MB | 242 |
| GD 280 | 539 | O1I | 166 | P2104 TA | 241 |
| GMX 400 W | 622 | O1I-RC | 166 | P2104 TB | 242 |
| GRP1 | 623 | O3I | 166 | P2104 UA | 241 |
| ICM 100 IP | 498 | O3I-RC | 166 | P2104 UB | 242 |
| ICM 25 | 495 | O6I | 166 | PLM 1000-E | 514 |
| LD 260 Aspheric 2D and 3D | 590 | O6I-RC | 166 | PLM 600-E | 514 |
| Linear 1200 | 505 | O8I | 166 | PS 10 | 524 |
| Linear 2000 | 505 | O8I-RC | 166 | Pocket Surf IV | 520 |
| Linear 800 | 505 | OMI-300P-1 | 308 | Precimar ICM 100 | 499 |
| M 310 | 528 | OMI-300P-2 | 308 | Q1I | 174 |
| M 310 C2 | 528 | OMI-300P-3 | 308 | Q1I-RC | 174 |
| M 310 PC | 530 | OMI-300P-4 | 308 | Q3I | 174 |
| M 310 | 528 | OMI-300P-5 | 308 | Q3I-RC | 174 |
| M 400 | 534 | OMI-300P-6 | 308 | Q6I | 174 |
| M36B-10 | 433 | OMI-300P-7 | 308 | Q6I-RC | 174 |
| M36B-20 | 433 | OMI-300P-8 | 308 | Q8I | 174 |
| MC-I | 15 | OMI-300P-9 | 308 | Q8I-RC | 174 |
| MFU 200 Aspheric 3D | 584 | OMI-301P-1 | 311 | Q8IT | 178 |
| MM 420 | 574 | OMI-301P-2 | 311 | S 1840 F | 220 |
| MM 420 CNC | 576 | OMI-301P-3 | 311 | S 1840 M | 220 |
| MMQ 100 | 605 | OMI-301P-4 | 311 | S 1840 PE/F | 221 |
| MMQ 100 | 609 | OMI-301P-5 | 311 | SCOPE 250 plus | 631 |
| MMQ 150 | 606 | OMI-301P-6 | 311 | SCOPE 600 plus 3D | 633 |
| MMQ 150 | 609 | OMI-301P-7 | 311 | SCOPE plus optical measuring instruments | 632 |
| MMQ 200 | 607 | OMI-301P-8 | 311 | SM 60 | 504 |
| MMQ 200 | 609 | OMI-301P-9 | 311 | SP6IS | 178 |
| MMQ 400 | 608-609 | Opto USB | 15 | SQ6IS | 178 |
| MSW 100 | 500 | P 1512 V | 252 | Software EasyShaft | 636 |
| MarCom Prof. | 10 | P 1530 V | 252 | Software MarWin | 617 |
| Maxµm III | 197-200, 202, 204 | P1/2I | 170 | UD 130 Aspheric 2D | 591 |
| Millimar - USB | 15 | P1/2I-RC | 170 | UD 130/LD 130/LD 260 | 548 |
| M-300P-1 | 307 | P1300 MA | 244 | ULM 1000 S-E | 509 |
| M-300P-2 | 307 | P1300 MA without cable | 244 | ULM 1000-E | 508 |
| M-300P-3 | 307 | P1300 MB | 245 | ULM 1500 L-E | 510 |
| M-300P-4 | 307 | P1300 MB without cable | 245 | ULM 1500-E | 508 |
| M-300P-5 | 307 | P1300 TA | 246 | ULM 300-E | 508 |
| M-300P-6 | 307 | P1300 TA ohne Kabel | 246 | ULM 520 S-E | 509 |
| M-300P-7 | 307 | P1300 TB | 247 | ULM 600-E | 508 |
| M-300P-8 | 307 | P1300 TB ohne Kabel | 247 | ULM 800 L-E | 510 |
| M-300P-9 | 307 | P1I | 170 | VD 140 | 544 |
| N 1701 PF-10000 | 227 | P1I-RC | 170 | VD 280 | 544 |
| N 1701 PF-2500/5000 | 227 | P2001 M | 234 | WI 100 | 564 |
| N 1701 | 227 | P2004 M | 235 | WI 50 | 563 |
| PF-2500/5000-4 | 227 | P2004 MA | 236 | WI 50 M | 562 |
| N 1701 PM-10000 | 227 | P2004 MB | 237 | XLI-22P-20 | 320 |
| N 1701 PM-2500 | 227 | P2004 T | 235 | XLI-57B-13 | 326 |
| N 1701 PM-5000 | 227 | P2004 TA | 236 | XLI-57B-15 | 323 |
| N 1701 PS | 230 | P2004 TB | 237 | XR 1 | 538 |
| N 1701 USB | 229 | P2004 U | 235 | e-Stick | 14 |
| N 1702 M | 224 | P2004 UA | 236 | i-Stick | 12 |
| N 1702 M-HR | 224 | P2004 UB | 237 | µDimensionair@II | 231 |
| N 1702 T | 224 | P2010 M | 238 | µMaxµm II | 194-196 |
| N 1702 U | 224 | P2010 MA | 239 | Dimentron | 372, 374, 376, 378 |
| N 1702 VPP | 226 | P2010 MB | 240 | | |
| N 1704 I/O | 228 | P2010 TA | 239 | | |
| N 1704 M | 224 | P2010 TB | 240 | | |
| N 1704 T | 224 | P2010 UA | 239 | | |
| N 1704 U | 224 | | | | |

Mahr | Alphabetical Index

| Product | Page | Product | Page | Product | Page |
|--|----------------------|--|---|---|---|
| 2 depth probes incl. carrier (rotatable) | 483 | Compact amplifier | 218–219 | Digital indicator | 132–144 |
| 2-jet air ring gage | 260 | Compact column amplifier | 220 | Digital inside micrometer | 92 |
| 2-jet blind hole air plug HCC | 255 | Compact column measuring instrument | 221 | Digital inside micrometer in set | 94 |
| A | | Compact form measuring machine | 605–607 | Digital inside quick probe | 337 |
| Adapter cable RS232-USB | 15 | Compact form measuring machine | 609 | Digital micrometer | 74–78, 80–87 |
| Adapter cable RS–232-USB | 15 | Conical contact point | 154 | Digital outer quick probe | 334 |
| Adapter for digital instruments und probes | 501 | Contour Measuring Station | 543 | Digital outside micrometers | 64 |
| Adaption cable (for foot swich via MarCom): jack plug Ø 3.5 mm/USB | 15 | Contour measuring station | 542 | Digital probe | 198–199 |
| Adjustable Stop | 283 | Cylindrical measuring pins | 426 | Digital special calipers | 42–55 |
| Adjustment pin | 265 | D | | Digital test indicator | 119 |
| Adjustment ring | 263–264 | Data Processing | 10, 12, 14–17 | Digital universal caliper | 36, 38, 40 |
| Angular holder | 159 | Data cable USB bidirectional | 15 | Digital universal calipers | 411 |
| Anvils for measuring arms | 430 | Data connection cable RS232C | 16 | Digital workshop caliper | 32–34 |
| Anvils with round measuring faces | 425 | Data connection cable USB | 15 | Display unit | 197 |
| Asphere measuring station | 590–591 | Depth micrometer | 101 | E | |
| Attachment Stand | 283 | Depth probe incl. holder | 483 | Electrical and Pneumatic Length Measuring Instruments | 218–224, 226–231, 234–242, 244–252, 255, 258, 260–265, 364, 398 |
| Außentaster | 266 | Depth stop | 399 | Extension for measuring depth | |
| B | | Depth stop with 3-point touching | 369 | F | |
| Ball anvil | 431 | Depth stops for 844 Tma, 844 Tmi, 844 Te | 418 | Fizeau interferometer | 592–593 |
| Ball contact | 79, 317 | Depth-Stop Bridge | 368 | Flat contact plates | 155 |
| Ball contact points | 155 | Depth-Stop Disc | 367 | Flat contact point | 154, 157 |
| Base with post | 282 | Depth-Stop Ring | 366 | Form measuring instruments | 584, 605–609, 617 |
| Basic Instrument Measuring Pistol | 99 | Dial Caliper | 29 | Fully automated dial indicator test bench | 498 |
| Basic software (V12) | 500 | Dial and Digital Indicators | 132–164, 166, 168, 170, 172, 174, 176, 178, 180–181 | G | |
| Basic unit | 98 | Dial comparator | 206–211 | Gage block comparator | 492–493 |
| Blind hole measuring probe | 394–395 | Dial indicator | 146–148, 150, 162–164, 166, 168, 170, 172, 174, 176, 178, 180 | Gage block holder and measuring jaws accessory set | 459 |
| C | | Dial indicator depth measuring bridge | 161 | Gage block maintenance accessories | 460 |
| CNC Workshop measuring microscope | 576 | Dial indicator with IP protection | 149 | Gear measuring instruments | 622–623 |
| Calibration measuring instruments | 508–510 | Digimar | 476–485, 487, 489 | H | |
| Caliper | 24–36, 38, 40, 42–59 | Digital 3D touch probe | 126 | Heavy measuring table | 281 |
| Caliper gage for external measurement | 332–333 | Digital Caliper | 24–28 | Height Gage | 476 |
| Caliper gage for internal measurement | 335–336 | Digital Micrometer | 64, 66–67, 69 | Height Measuring Instruments | 476–485, 487, 489 |
| Caliper with analog display | 30–31 | Digital Micrometer | 65, 68 | Height measuring and scribing instrument | 485, 487, 489 |
| Carrier for checking perpendicularity | 484 | Digital Micrometers | 65, 68 | Height measuring instrument | 477 |
| Carrier with a joint for a probe | 481 | Digital Micrometers | 69 | Holder | 121 |
| Center Bench with V-support | 288 | Digital and Dial Comparators | 188, 190, 192, 194–200, 202, 204, 206–211 | Holder for 2-point inner measuring devices | 502 |
| Center bench with roller support | 289 | Digital depth gage | 56–59 | Holder for Plug Gage | 362 |
| Combined contour and surface measuring station | 548 | | | Holder for indicator | 397 |

Mahr | Alphabetical Index

| Product | Page | Product | Page | Product | Page |
|---|--|--|---|--|---|
| I | | | | | |
| I/O module | 228 | Manual dial indicator testing position | 495 | Measuring computer | 222 |
| Incremental Probe | 252 | MarCal | 24–36, 38, 40, 42–59 | Measuring head | 100 |
| Indicating Measuring Instruments | 294–296, 298, 300–316, 318–337, 340–369, 372, 374, 376, 378, 382, 385, 388, 390, 392, 394–395, 397–400, 402–404, 406 | MarCator | 132–164, 166, 168, 170, 172, 174, 176, 178, 180–181 | Measuring instruments for the optical industry | 592–593 |
| Indicating bench snap gage | 314 | MarConnect | 10, 12, 14–17 | Measuring pistol | 95 |
| Indicating measuring instruments | 79, 317 | MarForm | 584, 605–609, 617 | Measuring pistol in set | 97 |
| Indicating plug gage | 340–361 | MarGage | 442–471 | Measuring rollers | 156 |
| Indicating plug gage for through hole | 372, 374, 376, 378 | MarGear | 622–623 | Measuring software | 223 |
| Indicating snap gage | 294–296, 298, 300–313 | MarOpto | 592–593 | Measuring spindle extension | 157 |
| Indicating thread snap gage | 315–316, 318–319 | MarShaft | 631–633, 636 | Measuring stand | 124, 402 |
| Indicator gage | 433–439 | MarShaft 600 plus 3D optical shaft measuring system | 633 | Measuring tables, measuring tripods, radial runout gages | 270–283, 287–289 |
| Inductive dial comparator | 188, 190, 192 | MarShaft SCOPE 350 / 750 / 1000 plus optical shaft measuring systems | 632 | Measuring tripod with magnetic base | 271–275 |
| Inductive digital comparator | 194–196, 200, 202, 204 | MarStand | 270–289 | Measuring tripod with triangular pedestal | 270 |
| Inductive probe | 234–242, 244–251 | MarSurf | 520, 524, 528, 530, 534, 538–539, 542–544, 548–549, 556–559, 562–564, 568, 590–591 | Mechanical 3D touch probe | 127 |
| Inside Micrometer Set | 89 | MarTest | 106–112, 114–127 | Micromar | 64–78, 80–92, 94–95, 97–101 |
| Inside measuring probe | 390, 392 | MarVision | 574, 576, 578–579 | Micrometer | 70 |
| Inside micrometer | 88, 90 | MaraMeter | 79 | Micrometer with integrated dial comparator | 71–72 |
| Inside micrometer in set | 91 | Marameter | 294–296, 298, 300–337, 340–369, 372, 374, 376, 378, 382, 385, 388, 390, 392, 394–395, 397–400, 402–404, 406 | Micrometers | 64–78, 80–92, 94–95, 97–101 |
| Inspection, testing and measuring equipment | 284–286 | Matched pair jet probes | 262 | Millimar | 218–224, 226–231, 234–242, 244–252, 255, 258, 260–265 |
| Interface Adapter with Data Cable Digimatic | 17 | Measuring Towers | 593 | Millimess | 188, 190, 192, 194–200, 202, 204, 206–211 |
| L | | | | | |
| Large dial indicator | 152 | Measuring and centering arm | 123 | Mobile Dial Calibrator | 181 |
| Large granite comparator stand | 280 | Measuring anvils | 430 | Mobile pneumatic length measuring instrument | 231 |
| Large granite comparator stand with fine adjustment | 280 | Measuring anvils with measuring blades | 423–424 | Mobile roughness measuring instrument | 520, 524, 528, 530 |
| Length measuring bench | 504 | Measuring arms | 427–429 | Mobile surface measuring instrument | 534 |
| | | Measuring attachment | 156 | Module for incremental sensors | 226 |
| | | | | Module for inductive probes | 224 |
| | | | | Module for pneumatic gages | 227 |
| | | | | Motorized dial indicator testing position | 499 |
| | | | | Mounting attachment | 419 |
| | | | | Mounting attachment offset by 90° | 420 |
| | | | | Mounting shaft | 120 |
| | | | | Multimar | 411, 416–439 |

Mahr | Alphabetical Index

| Product | Page | Product | Page | Product | Page |
|---|--|---------|------|---------|------|
| N | | | | | |
| Nozzle through-hole pin | 258 | | | | |
| O | | | | | |
| Optical Measuring Instruments | 579 | | | | |
| Optical flat | 461 | | | | |
| Optical parallel | 462 | | | | |
| Optical parallels | 463 | | | | |
| P | | | | | |
| Pin contact point | 157 | | | | |
| Plate for single measurement | 283 | | | | |
| Plate for sum measurement | 283 | | | | |
| Plug Gage Holder for inductive Probe | 363 | | | | |
| Portable thickness gages | 320–331 | | | | |
| Post and support assemblies | 276 | | | | |
| Power supply module | 230 | | | | |
| Precimar | 492–493, 495, 498–502, 504–505, 508–510, 514–515 | | | | |
| Precision 3D measuring station | 584 | | | | |
| Precision bench micrometer | 73 | | | | |
| Precision length measurement | 492–493, 495, 498–502, 504–505, 508–510, 514–515 | | | | |
| Precision length measuring machine | 514–515 | | | | |
| Probe carriers | 481 | | | | |
| Probe carriers 817 CLM | 482 | | | | |
| Probe holder | 282 | | | | |
| Probe set | 478–479 | | | | |
| R | | | | | |
| Radial runout gage with center supports | 287 | | | | |
| Receiver | 14 | | | | |
| Receiver for instruments with Integrated Wireless | 12 | | | | |
| Rectangular gage block set made of ceramic | 448–452 | | | | |
| Rectangular gage block set made of steel | 442–447 | | | | |
| Rectangular gage blocks made of ceramic | 456–458 | | | | |
| Rectangular gage blocks made of steel | 453–455 | | | | |
| Right Angle Attachment | 365, 399 | | | | |
| Ring gage | 467–469 | | | | |
| Roller blades, carbide | 79, 317 | | | | |
| Roughness Probe | 623 | | | | |
| Roughness and Contour Measuring Station | 544 | | | | |
| Roughness measuring station | 538–539 | | | | |
| S | | | | | |
| Safety dial indicator | 151 | | | | |
| Self-centering dial bore gage | 382, 385, 388, 403 | | | | |
| Self-centring dial bore gage | 404, 406 | | | | |
| Sensor level | 160 | | | | |
| Set of miniature precision vises | 579 | | | | |
| Set of rack rails for measuring range | 578 | | | | |
| 200 x 100 mm | | | | | |
| Set of rack rails for measuring range | 578 | | | | |
| 250 x 170 mm | | | | | |
| Set of rack rails for measuring range | 578 | | | | |
| 400 x 250 mm | | | | | |
| Setting and measuring instrument | 505 | | | | |
| Setting device | 432 | | | | |
| Setting disc | 470–471 | | | | |
| Setting rings in Set | 400 | | | | |
| Shaft measuring instruments | 631–633, 636 | | | | |
| Shoulder anvils | 421–422 | | | | |
| Single jet probe | 262 | | | | |
| Small ceramic comparator stand | 278 | | | | |
| Small ceramic comparator stand with fine adjustment | 278 | | | | |
| Small comparator stand, plate made of granite | 279 | | | | |
| Small dial indicators | 145 | | | | |
| Small steel comparator stand | 277 | | | | |
| Software interface | 10 | | | | |
| Spherical contact plates, steel | 156 | | | | |
| Spherical contact point | 153 | | | | |
| Stand for vise with 15 mm jaw width | 579 | | | | |
| Stand for vise with 25 mm jaw width | 579 | | | | |
| Stand for vise with 35 mm jaw width | 579 | | | | |
| Standard contact point | 153 | | | | |
| Standards and gage blocks | 442–471 | | | | |
| Straight holder | 158 | | | | |
| Support Arm with fine adjustment | 282 | | | | |
| Support Arm without fine adjustment | 282 | | | | |
| Support arm with dovetail guide | 282 | | | | |
| Surface Measuring Instruments | 520, 524, 528, 530, 534, 538–539, 542–544, 548–549, 556–559, 562–564, 568, 590–591 | | | | |
| Surface plate made from granite | 284–286 | | | | |
| T | | | | | |
| Test Indicators and Touch Probes | 106–112, 114–127 | | | | |
| Test indicator | 106–112, 114–118 | | | | |
| Thread pin gage | 464 | | | | |
| Thread pin gages set | 466 | | | | |
| Thread pin gages, holder pair | 465 | | | | |
| U | | | | | |
| USB connecting module | 229 | | | | |
| Universal Measuring Instruments | 411, 416–439 | | | | |
| Universal centering support frame | 125 | | | | |
| Universal form measuring machine | 608–609 | | | | |
| Universal gear measuring center | 622 | | | | |
| Universal holder with dovetail clamp | 122 | | | | |
| Universal measuring instrument | 416–417 | | | | |
| Universal probe set | 480 | | | | |
| Universal, fully automatic optical shaft measuring system | 631 | | | | |
| MarShaft SCOPE 250 plus | | | | | |
| V | | | | | |
| Vise with 15 mm jaw width | 579 | | | | |
| Vise with 25 mm jaw width | 579 | | | | |
| Vise with 35 mm jaw width | 579 | | | | |
| W | | | | | |
| Wedge shaped contact points | 154 | | | | |
| Workshop calipers | 35 | | | | |
| Workshop measuring microscope with M3 software | 574 | | | | |

America

United States

Mahr Inc. (local H. Q.)

1139 Eddy Street
Providence, RI 02905, USA
Phone: +1 401 784-3100
+1 800 343-2050 (toll-free)
Fax: +1 401 784-3246
information@mahr.com

Mahr Inc. - South Carolina Center of Excellence

4450 Olympic Blvd.
Erlanger, KY 41018, USA
Phone: +1 859 525-6116
Fax: +1 859 525-0481
information@mahr.com

Mahr Inc. - L.A. Center of Excellence

11135 Knott Avenue, Suite H
Cypress, CA 90630, USA
Phone: +1 714 379-7051
Fax: +1 714 379-0468
information@mahr.com

Mahr Inc. - Detroit Center of Excellence

48325 Alpha DRIVE, Suite 100
Phone: +1 (248) 560-6259
Fax: +1 (248) 924-2012
Wixom, MI 48393, USA
information@mahr.com

Mahr Inc. - South Carolina Center of Excellence

7001-A Pelham Road
Greenville, SC 29615, USA
Phone: +1 800-343-2050
Fax: +1 864-203-3275
information@mahr.com

Mahr Metering Systems Corporation

1415 A Cross Beam Dr.
Charlotte, NC 28217, USA
Phone: +1 704 525-7128
+1 800 459-7867 (toll-free)
Fax: +1 704 525-8290
information@mahrusa.com

Mexico

Mahr Corp. de México S.A. de C.V.

Francisco Garza Sada #690,
Col. Chepevera
64030 Monterrey,
Nuevo León, Mexico
Phone: +52 81 8333-2010
ventas_mexico@mahr.com

Brazil

Mahr do Brasil Ltda.

Av. João Pescarini
590 - Vinhedo, São Paulo
13280-144, Brazil
Phone: +55 (19) 3876-8600
Fax: +55 11 98203-9834
apoio.vendas@mahr.com

Europe

Germany

Mahr GmbH (Headquarters)

Carl-Mahr-Str. 1
D-37073 Göttingen, Germany
Phone: +49 551 7073-800
Fax: +49 551 7073-888
info@mahr.com

Mahr GmbH

Esslingen site
Reutlinger Straße 48
73728 Esslingen, Germany
Phone: +49 711 9312-600
Fax: +49 711 9312-725
info@mahr.com

Mahr GmbH

Jena site
Max-Grossmann-Str. 1
07745 Jena, Germany
Phone: +49 551 7073 800
Fax: +49 551 7073 808
info@mahr.com

Mahr GmbH South West Branch

Reutlinger Straße 48
73728 Esslingen, Germany
Phone: +49 711 9312-800
Fax: +49 711 9312-815
Niederlassung-Suedwest@mahr.com

Mahr GmbH Northern Branch

Hatzfelder Straße 161
42281 Wuppertal, Germany
Tel. +49 202 758187-0
Fax +49 202 758187-19
Niederlassung-Nord@mahr.com

Mahr GmbH South East Branch

Hopfenstraße 30
85283 Wolnzach, Germany
Phone: +49 8442 96266-0
Fax: +49 8442 96266-11
Niederlassung-Suedost@mahr.com

Mahr MWF GmbH

Melberstraße 9
63762 Grobostheim, Germany
Phone: +49 6026 9728-0
Fax: +49 6026 9728-20
info-mwf@mahr.com

Poland

Mahr Polska Sp. z o.o.

ul. Gimnazjalna 4
01-364 Warszawa, Poland
Phone: +48 22 862 39 97
mahr.polska@mahr.com

Czech Republic

Mahr, spol. S.r.o.

Ulice Kpt. Jaroše 552
41712 Proboštov,
Czech Republic
Phone: +420 417 816 735
info-cz@mahr.com

Slovakia

Mahr Metrológia, s.r.o.

Seberíniho 482/1
821 03 Bratislava, Slovakia
Phone: +421 2 321 212 16
info-sk@mahr.com

Hungary

Mahr Magyarország Kft.

Gyár utca 2
2040 Budaörs, Hungary
Phone: +36 1 414 0177
Fax: +36 1 414 0178
office.hungary@mahr.com

Austria

Mahr Austria GmbH

Hirschstettnerstraße 19-21
1220 Vienna, Austria
Phone: +43 1 204 36 73-0
Fax: +43 1 204 36 73-15
info-at@mahr.com

France

Mahr France SARL

6, rue Lavoisier - Z.I.
91430 Igny, France
Phone: +33 1 69351919
Fax: +33 1 69351900
info@mahr.com

Switzerland

Mahr AG Schweiz

Zürcherstrasse 68
8800 Thalwil, Switzerland
Phone: +41 44 723 39 99
Fax: +41 44 723 39 98
info-ch@mahr.com

Great Britain / Ireland

Mahr UK Ltd.

19 Drakes Mews
Crownhill, Milton Keynes
MK 8 0ER, Great Britain
Phone: +44 1908 563700
Fax: +44 1908 563704
salesuk@mahr.com

Spain

Mahr Metrologia, S.L.

Av. Vía Augusta, 15-25
Edificio @ Sant Cugat B-2 Pl. 1 Of. 13
08174 Sant Cugat del Vallés –
Barcelona, Spain
Phone: +34 (93) 534 22 83
info.es@mahr.com

Asia

China

Mahr Precision Metrology (Suzhou) Ltd.

No.399, Suhong Zhong Road,
Suzhou Industrial Park,
215122 Suzhou, China
Phone: +86 512 6258 5862
Fax: +86 512 6258 5816
infochina@mahr.com

Mahr Precision Metrology (Suzhou) Ltd.

Shanghai Branch

Room 304, No. 14, Lane 1401,
Jiangchang Road, Jing 'an District,
200435 Shanghai, China
Phone: +86 21 52385353
Fax: +86 21 52386012
infochina@mahr.com

Mahr Ltd.

Room 2101, Peninsula Tower,
538 Castle Peak Road, Lai Chi Kok,
Kowloon, Hong Kong, China
Phone: +852 2357 9683
Fax: +852 2763 9613
infochina@mahr.com

Korea

Mahr Korea Ltd.

#701-703, Ace Hitech City
Byeomgye 29 Simin-daero 109
Byeon-gil, Dongan-gu, Anyang City
14042 Gyeonggi-do, South Korea
Phone: +82 2 579 4981
Fax: +82 2 579 4986/7
sales-seo@mahr.com

Japan

Mahr Japan Co., Ltd.

712-4-1, Mamedo-cho, Kohoku-ku,
222-0032 Yokohama, Japan
Phone: +81 45 540-3591
Fax: +81 45 540-6251
info@mahr.jp

Malaysia

Mahr Malaysia Sdn. Bhd.

No. 130, Block B 1,
Leisure Commerce Square
No. 9, Jalan PJS 8/9,
46150 Petaling Jaya, Selangor
Malaysia
Phone: +60 3 7877-2060
Fax: +60 3 7877-2040
sales_msea@mahr.com

Thailand

Mahr S.E.A. Co. Ltd.

719 KPN Tower, 20th Floor
Rama 9 Rd., Bangkapi, Huaykwang
Bangkok 10310, Thailand
Phone: +66 2 717 1050-2
Fax: +66 2 717 1055
sales_msea@mahr.com

India

Mahr Metrology India Pvt. Ltd. Corporate Office, Chennai

B-6, Reddipalayam Road,
4th Street, Mogappair West Estate,
Chennai - 600 037, India
Phone: +91 (44) 4617 5555
Fax: +91 (44) 4617 5505
Sales: +91 91580 02282
Service: +91 80560 78681
Sales Support: mahrindia@mahr.com
Service Support: Service.India@mahr.com

Mahr Metrology India Pvt. Ltd. Bangalore Office

No.6 & 13, 5th 'C' Cross, 3rd Main Road,
St. Claret College Road,
Sharadambanagar, Jalahalli Village,
Bangalore - 560013, India
Sales: +91 78239 46909
Service: +91 95919 97818
Sales Support: mahrindia@mahr.com
Service Support: Service.India@mahr.com

Mahr Metrology India Pvt. Ltd. Pune Office

Bangalow no 10, Mahindra Society,
Shastrinagar, Pune
Maharashtra 411006, India

Mahr Metrology India Pvt. Ltd. Gurgaon Office

P806-P807 8th floor
JMD Megapolis Sohna Road
Sector 48 Gurgaon
Haryana 122001, India

Ahmedabad (Gujarat & MP)

Sales: +91 90990 94080
Service: +91 90990 05302

The addresses of our dealers around the world (outside of the Mahr Group) can be found on our website www.mahr.com

© by Mahr GmbH, Göttingen

We reserve the right to modify our products, especially in light of technical improvements and further developments. All illustrations, numerical values, etc. are therefore subject to change.

3766075 – 02.2023
Printed in Germany



Mahr GmbH
Carl-Mahr-Straße 1
D-37073 Göttingen
Germany

Phone: +49 551 7073 800
info@mahr.com
www.mahr.com



© Mahr GmbH

We reserve the right to make changes to our products,
especially due to technical improvements and further developments.
All illustrations, numerical values, etc. are therefore subject to change.

3766075 | 02.2023



New Products 2022



Content

| | |
|---|-----------|
| Digimar Overview | 4 |
| Height Measuring Instruments | |
| Digimar 817 CLT | 6 |
| Height Measuring Instrument | |
| Digimar Accessories | 7 |
| | |
| Millimes Overview | 14 |
| Comparators | |
| Millimes 2000 W / 2000 Wi | 16 |
| Inductive Comparators | |
| Millimes 2001 W / 2001 Wi | 18 |
| Inductive Comparators | |
| | |
| Mar4D PLQ | 22 |
| Cylinder Coordinate Measuring Machines | |
| Mar4D PLQ 4200 | 24 |
| Cylinder Coordinate Measuring Machine | |
| | |
| MarSurf Overview | 26 |
| Contour Measuring Instruments | |
| MarSurf CD 140 AG 11 | 28 |
| Contour Measuring Station | |
| | |
| Reference Form Tester Overview | 30 |
| Form Measuring Instruments and Measuring Instruments for the Optical Industry | |
| MarForm MFU 200 | 32 |
| Reference Form Measuring Station | |
| MarOpto MFU 200-3D | 34 |
| Precision 3D Measuring Station | |

Digimar 817 CLT: Easy measurements using intuitive touch control



Best connection for secure data

Data can be transferred wirelessly or via USB cable via the MarConnect interface. Quickly print out a series of measurements? A Bluetooth printer is available for this purpose. Simply choose between complete measuring records in PDF format or save your measuring records as a TXT file.



Interfaces for dial indicators

An interface integrated in the slide enables the error-free measurement of the perpendicularity and straightness using the new Millimes 2000/2001W dial comparators.



Ergonomics that can be measured

Ergonomics means that the methods, processes, and arrangement are designed for people and not the other way around. This is exactly what the new Digimar 817 CLT stands for: The simple moving and scrolling functions of the touchscreen work just like smartphone and tablet. The keys on the display are already arranged in such a way that frequently used functions are particularly easy to access. The measurements on the measuring slide can easily be started by hand via the touch display, the thumbwheel with integrated arrow keys, or using Quick mode. Two pushbuttons to actuate the air bearings are integrated into the handle enabling the device to be guided safely and sensitively by left- and right-handed operators. Regardless of whether you prefer to sit or stand while working: The touch display is always at eye level and can be rotated and tilted as required. This ensures the measuring process is particularly comfortable and relaxed.





Simple touch measurement

Intuitive operation via large, clearly defined keys to ensure the safe completion on measurements, setting and calculation of functions, and the creation of measuring programs via Drag & Drop.

Pivoting display

10-inch touch panel with turn/tilt joint so that it can be set individually for the work position, height of the operator, and lighting conditions.



Easy handling

The thumbwheel can be used to move the measuring slide quickly and easily start the measurement. The quick measurement function keys also automatically detect surfaces and bores.



Best ergonomics

Ergonomic handles on both sides have an integrated operating key for the air bearing ensuring the device can be moved accurately and effortlessly on the measuring plate.



Digimar 817 CLT

Height measuring instrument



FEATURES

Operating and display unit

- Large and clearly defined touch display with backlighting
- Operator guidance with self-explanatory icons
- Multilingual user guidance
- Option of setting additional zero points on the workpiece
- Additional measuring instrument can be connected via MarConnect USB port
- Future-proof thanks to software updates
- Automatic activation of standby mode
- Selectable auto-off function, without loss of measured values



Functions

- Top or bottom contacting
- Web width or distances between grooves, including center of web or groove
- Bore or shaft diameter, including center of bore or shaft
- Bore reversing point (up or down)
- Shaft reversing point (up or down)
- Calculating distances or symmetry
- Dynamic measuring functions
- Perpendicularity measurement
- Straightness measurement
- Measurement in 2D mode
- Measuring programs
- Measuring data processing

Measuring system

- Optical incremental measuring system for outstanding measuring accuracy and reliability
- Dynamic probe system enabling high repeatability
- Air bearing system for light and smooth movement
- Motorized measuring slide simplifies measurement runs
- Probe constant remains after the instrument is switched off
- Integrated rechargeable battery with a long operating life for mains-independent measurement
- Temperature compensation via internal temperature sensor

Scope of delivery

- Height measuring instrument incl. operating and display element
- Carrier 817 h1
- Measuring anvil K6/51
- Setting gage 817 eb
- USB cable
- Operating instructions
- Recharging unit
- Protective cover
- Calibration certificate

TECHNICAL DATA

| Order no. | 4429600 | 4429601 | 4429602 |
|----------------------------------|------------|---|----------|
| Product type | | 817 CLT | |
| Measuring range | mm 0 – 350 | 0 – 600 | 0 – 1000 |
| Application range from | mm | 170 | |
| Application range up to | mm 520 | 770 | 1170 |
| Resolution | mm | 0.01, 0.005, 0.001, 0.0005, 0.0001 | |
| Resolution | inch | .001", .0005", .0001", .00005", .00001" | |
| Error limit | µm | (1.8 + L/600) L in mm | |
| Repeatability bores | µm | 1 | |
| Repeatability planes | µm | 0.5 | |
| Perpendicularity error in µm | µm | 5 | 6 10 |
| Operating time max. | h | 14 | |
| Measuring force | N | 1.0 +/- 0.2 N | |
| Relative humidity non-condensing | % | 65 | |
| Working temperature | °C | 20 | |
| Operating temperature | °C | 10 – 40 | |
| Product weight | kg | 22 | 26 29 |
| Data interface | | USB, Wireless | |
| Standard | | Factory standard | |

ACCESSORIES

| Order no. | Product name | Product type |
|-----------|--|--------------|
| 6910271 | Printer set incl. Bluetooth USB adapter | DP-B1 |
| 4102220 | USB adapter for MarConnect Wireless | i-stick |
| 4221525 | Surface plate made from granite, 1000 x 630 mm | 107 G |
| 5450105 | Printer paper, 12 rolls | |
| 4221573 | Stand, 1000 x 630 mm | 107 Ug |
| 4221526 | Surface plate made from granite, 1200 x 800 mm | 107 G |
| 4221574 | Stand, 1200 x 800 mm | 107 Ug |

Software

- MarCom Professional can be downloaded free of charge from: www.mahr.com/marcom (only for Mahr data cable and wireless systems with USB and RS-232 interface)



i-Stick



107 G + 107 Ug



DP-B1

Digimar 817 ts1

Probe set

FEATURES

- Large accessory kit
- Packaged in a practical plastic case
- Consisting of:
 - Depth probe
 - Carrier with extended holder
 - Disc measuring probe for grooves, etc.
 - Conical measuring probe
 - Cylindrical measuring probe
 - Holder for test indicator styli with M2 thread
 - Carrier including 4 spherical probes with shaft diameter 8 mm
- Package contains: case

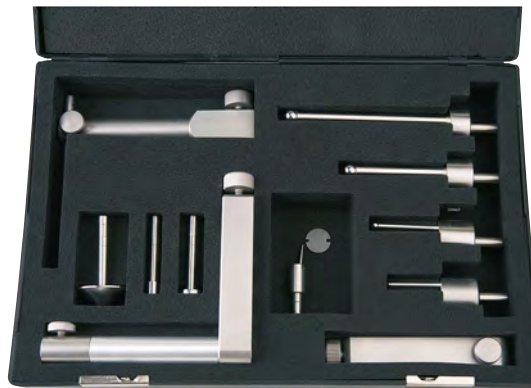

TECHNICAL DATA

| Order no. | Product type |
|-----------|--------------|
| 4429019 | 817 ts1 |

COMPONENTS INCLUDED IN SET

| Order no. | Product name | Product type |
|-----------|--|--------------|
| 4429219 | Carrier for a probe, mounting hole 6 mm, a = 100.5 mm, b = 119.5 mm, c = 84 mm | 817 h2 |
| 4429226 | Disc probe \varnothing 15 mm | S 15/31.2 |
| 4429227 | Cylindrical probe \varnothing 10 mm | Z 10/31.2 |
| 4429228 | Taper probe | MKe 30 |
| 4429221 | Depth probe incl. Holder | TMT 120 |
| 4429256 | Probe with M2 threads for 3 styli positions ($0^\circ/10^\circ/90^\circ$), incl. styli 800 ts \varnothing 2.0 mm | KM 2 |
| 4429220 | Carrier for probes 817 CLM, mounting hole 8 mm | 817 h4 |
| 7023813 | Probe with mount, \varnothing 4.0 mm | K 4/30 |
| 7023816 | Probes with mount, \varnothing 6 mm | K 6/40 |
| 7023810 | Probes with mount, \varnothing 10.0 mm | K 10/60 |
| 7023615 | Probes with mount, \varnothing 10.0 mm | K 10/100 |

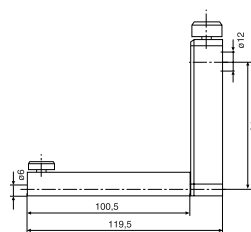

817 h2

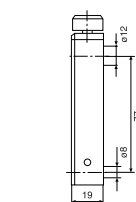

817 h4

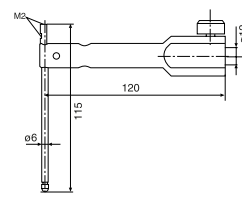

TMT 120

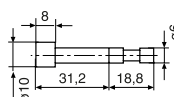

Z 10/31.2

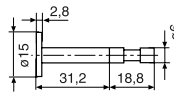

S 15/31.2

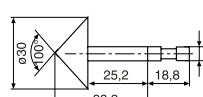

MKe 30

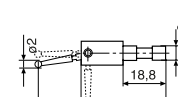

KM 2

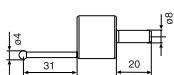

K 4/30



K 6/40

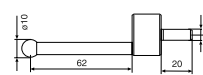

K 10/60

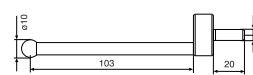

K 10/100

Digimar 817 ts2

Probe set

FEATURES

- Small accessory kit
- Packaged in a practical plastic case
- Consisting of:
 - Depth probe
 - Carrier with extended holder
 - Disc measuring probe for grooves, etc.
 - Conical measuring probe
 - Cylindrical measuring probe
 - Holder for test indicator styli with M2 thread
- Package contains: case

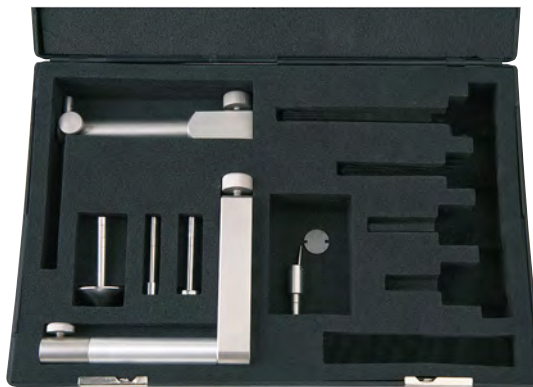

TECHNICAL DATA

| Order no. | Product type |
|-----------|--------------|
| 4429018 | 817 ts2 |

COMPONENTS INCLUDED IN SET

| Order no. | Product name | Product type |
|-----------|--|--------------|
| 4429219 | Probe carrier, mounting hole 6 mm, a = 100.5 mm, b = 119.5 mm, c = 84 mm | 817 h2 |
| 4429226 | Disc probe \varnothing 15 mm | S 15/31.2 |
| 4429227 | Cylindrical probe \varnothing 10 mm | Z 10/31.2 |
| 4429228 | Taper probe | MKe 30 |
| 4429221 | Depth probe including holder | TMT 120 |
| 4429256 | Probe incl. styli 800 ts \varnothing 2.0 mm | KM 2 |

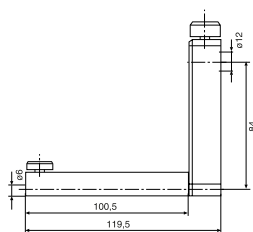

817 h2

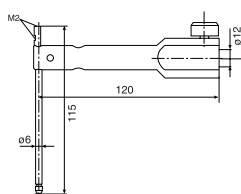

TMT 120

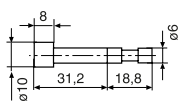

Z 10/31.2

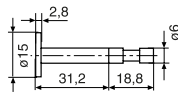

S 15/31.2

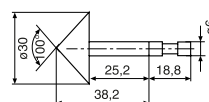

MKe 30

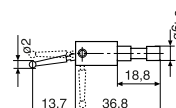

KM 2

Digimar 817 ts3

Universal probe set

FEATURES

- Accessory kit for small parts and delicate grooves, recesses and bores
- Packaged in a practical wooden case
- Suitable for 817 h4 carriers with 8 mm mounting bore
- Consisting of:
 - Base with 8 mm holding shaft
 - Depth probe
 - Probe shoe for grooves and recesses
 - Spherical measuring probe
 - Conical measuring probe
 - Extension
 - Adapter for M2.5 measuring anvils
- Package contains: case

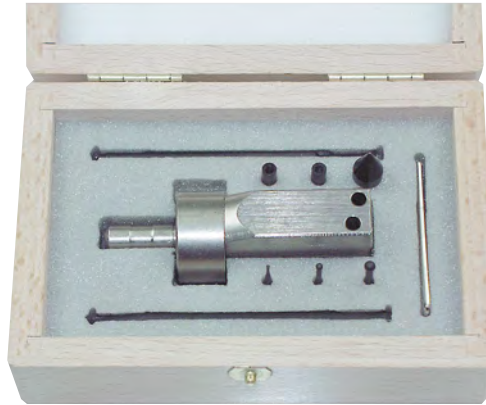

TECHNICAL DATA

| Order no. | Product type |
|-----------|--------------|
| 7034000 | 817 ts3 |

COMPONENTS INCLUDED IN SET

| Order no. | Product name | Product type |
|-----------|---|--------------|
| 3015917 | Probe carrier | GK/8 |
| 3015918 | Measuring crook, $d = 0.5 \text{ mm}$, $l = 78 \text{ mm}$ | TS 0.5/78 |
| 3015919 | Probe pin/tip, $d = 1.2 \text{ mm}$, $l = 75 \text{ mm}$, $l_s = 15.5 \text{ mm}$ | T 1.2/75 |
| 3015920 | Taper probe | MKe 8 |
| 3022000 | Spherical probe, $d_k = 3.0 \text{ mm}$, $l = 24 \text{ mm}$ | K 3/24 |
| 3022001 | Spherical probe, $d_k = 2.0 \text{ mm}$, $l = 24 \text{ mm}$ | K 2/24 |
| 3022002 | Spherical probe, $d_k = 1.0 \text{ mm}$, $l = 24 \text{ mm}$ | K 1/24 |
| 3015888 | Extension M3 - M2.5, $d = 4 \text{ mm}$, $l = 20 \text{ mm}$ | V/M 2.5 |
| 3015921 | Extension M3 - M3, $d = 4 \text{ mm}$, $l = 20 \text{ mm}$ | V/M 3 |

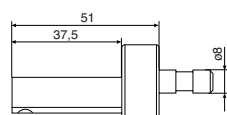

GK/8

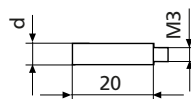

V/M2...M3

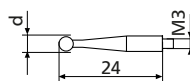

K 1...K3/24

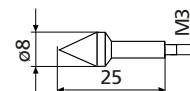

Mke 8

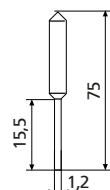

T 1.2/75

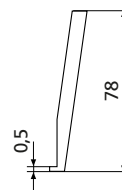

TS 0.5/78

Digimar 817 h1 / 817 h2 / 817 h5

Probe carriers

FEATURES

- Carrier for probes with 6 mm holding shaft
- Used for measurements at increased measuring depth (817 h2)
- Pivoting (817 h5) e.g. for aligning a cylindrical measuring probe



TECHNICAL DATA

| Order no. | Product type |
|-----------|--------------|
| 4429154 | 817 h1 |
| 4429219 | 817 h2 |
| 4429454 | 817 h5 |

| Order no. | a | b | c | Mounting hole |
|-----------|-------|-------|----|---------------|
| | mm | mm | mm | |
| 4429154 | 27.5 | 46.5 | 84 | 6 mm |
| 4429219 | 100.5 | 119.5 | 84 | 6 mm |
| 4429454 | 35 | 54 | 86 | 6 mm |

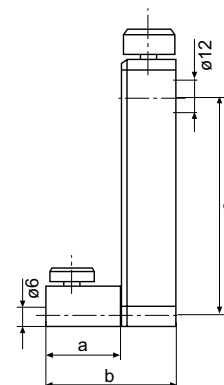

ACCESSORIES

| Order no. | Product name | Product type |
|-----------|--|--------------|
| 4301865 | Mounting shaft \varnothing 6 mm for touch probes | 800 a6 |
| 4429158 | Spherical probe, \varnothing 5.0 mm | K 5/51 |
| 4429226 | Disc probe \varnothing 15 mm | S 15/31.2 |
| 4429227 | Cylindrical probe \varnothing 10 mm | Z10/31.2 |
| 4429228 | Taper probe | MKe 30 |
| 4429254 | Spherical probe for 817 CLM, \varnothing 6 mm | K 6/51 |
| 4429256 | Probe including styli 800 ts \varnothing 2.0 mm | KM 2 |

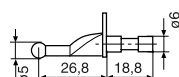

K 5/51

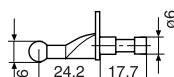

K 6/51

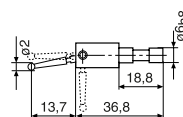

KM 2

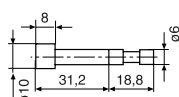

Z 10/31.2

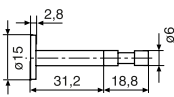

S 15/31.2

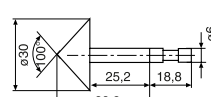

MKe 30

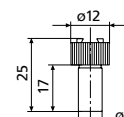

800 a6

Digimar 817 h4

Probe carriers 817 CLM

FEATURES

- Carrier for measuring anvils with 8 mm holding shaft and weighing 102 g
- Suitable for the CXt2 universal measuring probe set
- Compatible with Digimar CX1 and CX2 probes weighing 102 g



TECHNICAL DATA

| Order no. | Product type | Mounting hole |
|-----------|--------------|---------------|
| 4429220 | 817 h4 | 8 mm |

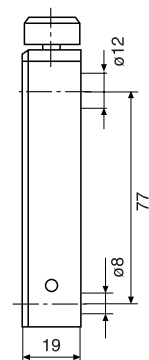

ACCESSORIES

| Order no. | Product name | Product type |
|-----------|---|--------------|
| 3015888 | Extension M3 - M2.5, d = 4 mm, l = 20 mm | V/M 2.5 |
| 3015917 | Probe carrier | GK/8 |
| 3015918 | Measuring crook, d = 0.5 mm, l = 78 mm | TS 0.5/78 |
| 3015919 | Probe pin/tip, d = 1.2 mm, l = 75 mm, ls = 15.5 mm | T 1.2/75 |
| 3015920 | Taper probe | MKe 8 |
| 3015921 | Extension M3 - M3, d = 4 mm, l = 20 mm | V/M 3 |
| 3022000 | Spherical probe, d _k = 3.0 mm, l = 24 mm | K 3/24 |
| 3022001 | Spherical probe, d _k = 2.0 mm, l = 24 mm | K 2/24 |
| 3022002 | Spherical probe, d _k = 1.0 mm, l = 24 mm | K 1/24 |
| 7023615 | Probes with mount, ø 10.0 mm | K 10/100 |
| 7023810 | Probes with mount, ø 10.0 mm | K 10/60 |
| 7023813 | Probe with mount, ø 4.0 mm | K 4/30 |
| 7023816 | Probes with mount, ø 6 mm | K 6/40 |

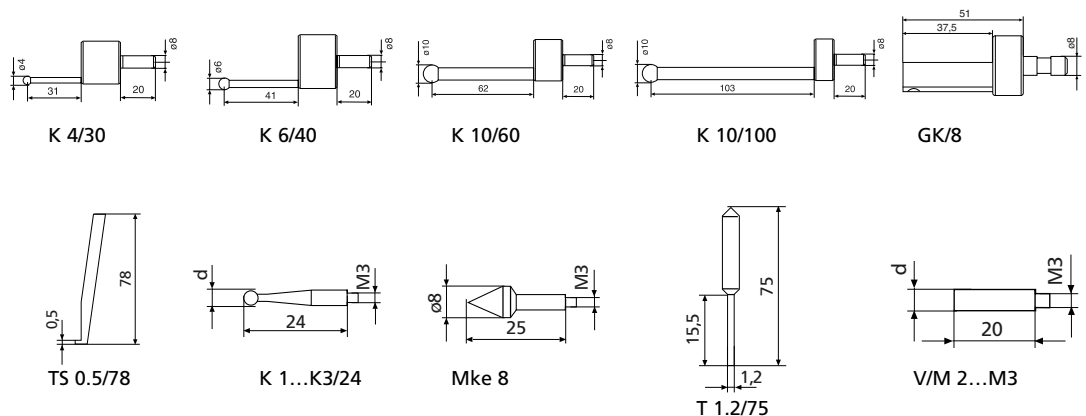

Digimar TMT 120 / TMT 120 S

Depth probe including holder

FEATURES

- Depth probe and carrier for measurements in vertical bores and recesses
- Interchangeable depth probe
- M2 and M2.5 connecting threads for measuring anvils
- M2.5 spherical contact point
- 901 H
- pivoting (TMT 120 S only)
- Second depth probe with probe shoe for groove measurement (TMT 120 S only)
- M2 stylus 800 ts with 2 mm ball (TMT 120 S only)

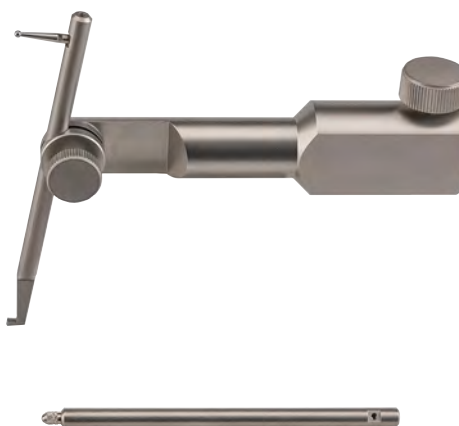

TECHNICAL DATA

| Order no. | Product type |
|-----------|--------------|
| 4429221 | TMT 120 |
| 4429421 | TMT 120 S |

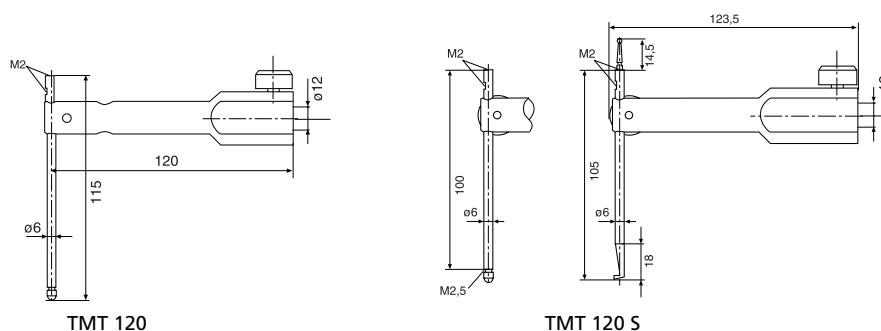

ACCESSORIES

| Order no. | Product name | Product type |
|-----------|---|--------------|
| 4305870 | Stylus \varnothing 1.0 mm, carbide, $l = 14.5$ mm | 800 ts |
| 4305850 | Stylus \varnothing 2.0 mm, carbide, $l = 14.5$ mm | 800 ts |
| 4305871 | Stylus \varnothing 3.0 mm, carbide, $l = 14.5$ mm | 800 ts |
| 4309051 | Stylus \varnothing 2.0 mm, ruby, $l = 14.5$ mm | 800 tsr |
| 4360001 | Standard contact point, steel, $r = 1.5$ mm | 901 |
| 4360002 | Standard contact point, carbide, $r = 1.5$ mm | 901 H |
| 4360003 | Standard contact point, ruby, $r = 1.5$ mm | 901 R |
| 4360241 | Pin contact point, carbide, $l = 11$ mm, measuring surface \varnothing 1.5 mm | 911 H2 |

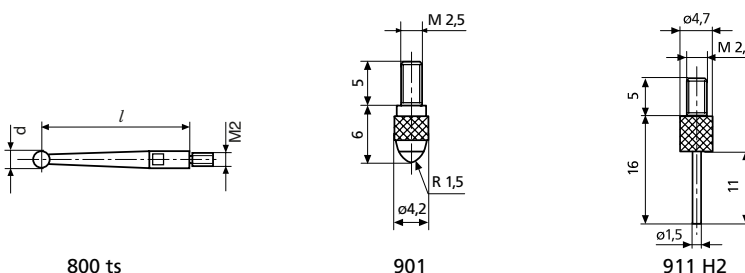

Digimar 817 h3

Carrier for checking perpendicularity

FEATURES

- Carrier for perpendicularity measurement
- Suitable for analog and digital dial indicators
- Ideal with P1514H measuring probe (817 CLM only)



TECHNICAL DATA

| Order no. | Product type |
|-----------|--------------|
| 4429206 | 817 h3 |

| Order no. | Mounting hole |
|-----------|---------------|
| 4429206 | 8 mm |

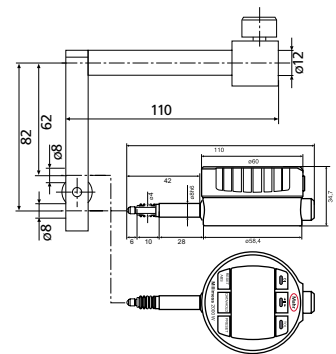

ACCESSORIES

| Order no. | Product name | Product type |
|-----------|------------------------------------|--------------|
| 4429610 | Data connection cable RS232C (2 m) | DK-M1 |
| 4346700 | Digital indicator 0.0001mm/±1mm | 2000 W |
| 4346800 | Digital indicator 0.0001mm/±1mm | 2001 W |



2001 W



2000 W



DK-M1

Millimes 2001 Wi: Everything under control! A digital dial comparator – highest level of precision thanks to inductive measuring system



Integrated Wireless

- Integrated wireless interface
- Sending and receiving measuring data and various parameters



Lock individual keys and functions

Remote-controlled settings can be configured easily using MarCom Professional software



Can be configured and controlled remotely using MarCom Professional software



First digital comparator indicator with touch operation



Unique touch operation – even works with gloves

Enormous advantages:

- Keys react even with the slightest touch
 - This prevents a measuring device from being adjusted or deformed
- **Maximum measuring certainty**

Hardened glass front

- Scratch and impact-resistant surface
- Excellent protection against scratches and penetrating liquids
- Wear-free keys react to the slightest touch



Protection rating IP 64

Excellent protection against dust and splash water from all directions ensures optimum workshop compatibility at all times



High-precision ball-bearing guide

Maximum sensitivity of the measuring system. long service life, and high loading capacity

Bi-directional data interface via USB

- Sending and receiving measuring data and various parameters
- Permanent power supply via data cable
- Possible to retrieve the device ID

#ID

Data interface via Digimatic

- To send measuring data



Convenient tolerance functions

- Clear tolerance symbols
- Colorful LED signals (red, green, yellow) to classify the measuring values
 - No go/Go/warning limit
 - No go/Go/rework

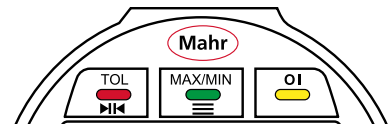

High precision inductive measuring system

Lowest measuring deviations thanks to linearization

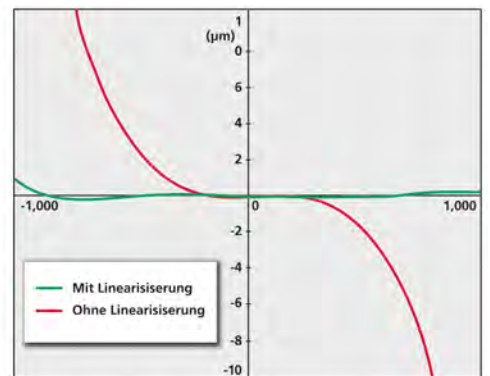

ABS system

Absolute measuring system

The reference to the electric zero point is not lost when the device is switched off

Millimes 2000 W / 2000 Wi

Inductive comparator



FUNCTIONS

- ON/OFF
- mm/inch
- RESET (set display to zero)
- PRESET (for entering a numerical value)
- ABS (reference to the electrical zero point)
- Selectable resolution
- TOL (Tolerance and Warning Limits Input)
- Factor (adjustable)
- Reversal of counting direction
- HOLD (storage of measured values)
- LOCK function (key lock)
- DATA (data transmission)
- Bi-directional data interface (external output and input option of characteristic values as well as setting of individual lock functions by software MarCom)

FEATURES

- **Tempered glass front with touch control panels with enormous advantages:**
 - scratch and impact resistant surface
 - excellent protection against dust, coolants and lubricants
 - wear-free touch operating keys
 - improved safety of measurement values in measuring stands, as only a light touch of the key – no keystroke is required, thus no adjustment or deformation of the measuring device
- High-contrast LCD display, thus very clear and safe to read
- Clear tolerance symbols and **colored LED signals (red, green, yellow) for measured value classification**
 - **with** warning limit input: No Go / Go / Warning Limit
 - **without** warning limit input: No Go / Go / Rework
- Operating and display unit (bezel) can be rotated through 280°
- Mounting shank and measuring spindle are both made of hardened stainless steel
- Measuring spindle is mounted in a high-precision ball guide for minimal hysteresis
- Linearized inductive absolute measuring system
- Measuring force spring is interchangeable
- Lower stop is adjustable
- Software: MarCom Professional free download: www.mahr.com/marcom (only for Mahr data cables and wireless systems with USB and RS-232 interface)

Application:

For static measuring tasks



TECHNICAL DATA

| Order no. | 4346700 | 4346701 |
|---|---------|--|
| Type | 2000 W | 2000 Wi |
| Measuring range | mm | ± 1 |
| Resolution | mm | 0.0001, 0.0002, 0.0005, 0.001, 0.002, 0.005, 0.01 |
| Resolution | inch | .000005", .00001", .00002", .00005", .0001", .0002", .0005" |
| Error limit | µm | ± (0.2 + 0.5 x L) L in mm |
| Measuring value hysteresis f _u | µm | 0.3 |
| Repeatability f _w | µm | 0.1 |
| Standard | | Factory standard |
| Free stroke | mm | 2.5 |
| Measuring force | N | 0.9±0.1 (Reference to absolute zero point of inductive measuring system) |
| IP protection category | | IP 64 |
| Supply voltage | | 100– 240 V |

- Digit height: 11.5 mm
- Data interface: USB, Digimatic
- Energy supply: Integrated rechargeable accumulator (up to 4 weeks) or powered by USB Data Cable
- Battery type: Lithium polymer battery 3.7 V
- Package contains: instruction manual, USB data and charging cable type DK-U1, plug-in power supply (with 4 interchangeable adapters) for USB, rubber bellows, screwdriver for pre-stroke adjustment (hexagon socket 0.9 mm), case

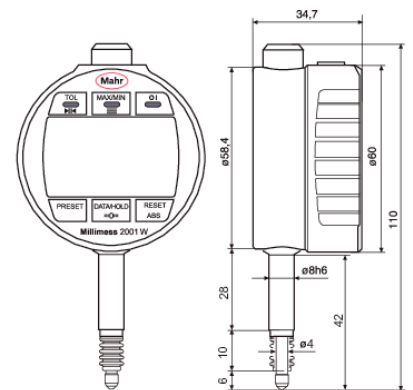

Millimess 2000 W / 2000 Wi

Inductive comparator

ACCESSORIES

| Order no. | Description | Type |
|-----------|---|---------|
| 4102603 | Data cable USB bi-directional (2 m) | DK-U1 |
| 4102606 | Interface adapter with data cable Digimatic (2 m) | DK-D1 |
| 4310103 | Adapter bushing (.375" / 8 mm) | 940 |
| 4346010 | Manual lifter with cable release | 2000 h |
| 4346011 | Pneumatic lifter | 2000 p |
| 4346012 | Measuring force adjuster | 2000 m |
| 4337421 | Lug back | 1086 b |
| 4346050 | Measuring force spring 0.25 N | |
| 4346051 | Measuring force spring 0.50 N | |
| 4882284 | Measuring force spring 0.75 N | |
| 4346052 | Measuring force spring 1.00 N | |
| 4346053 | Measuring force spring 1.50 N | |
| 4346054 | Measuring force spring 2.00 N | |
| 4346055 | Measuring force spring 2.50 N | |
| 4337900 | Display protection film, anti reflective frosted, made of extra hard hybrid glass, to protect against scratches and reflections | 1086 sf |
| 4346606 | Shock protection ring made of hard rubber for Millimess 2000 W(i) / 2001 W(i) | 1086 sr |
| 4102220 | Receiver for instruments with Integrated Wireless | i-Stick |

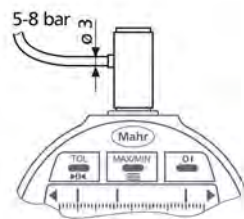

2000 p

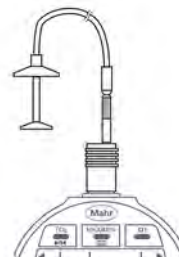

2000 h

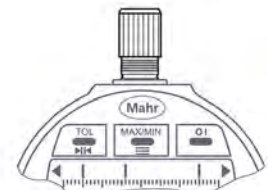

2000 m



1086 sf



1086 sr



i-stick

Millimes 2001 W / 2001 Wi

Inductive comparator



FUNCTIONS

- ON/OFF
- mm/inch
- RESET (set display to zero)
- PRESET (for entering a numerical value)
- ABS (reference to the electrical zero point)
- Selectable resolution
- TOL (Tolerance and Warning Limits Input)
- RANGE (switch the measuring range and resolution)
- MAX/MIN memory for searching the reversal point
- (MAX-MIN) for testing flatness and concentricity
- 0 (set the analog scale display to zero)
- Factor (adjustable)
- Reversal of counting direction
- HOLD (storage of measured values)
- LOCK function (key lock)
- DATA (data transmission)
- Bi-directional data interface (external output and input option of characteristic values as well as setting of individual lock functions by software MarCom)

FEATURES

- **Tempered glass front with touch control panels with enormous advantages:**
 - scratch and impact resistant surface
 - excellent protection against dust, coolants and lubricants
 - wear-free touch operating keys
 - improved safety of measurement values in measuring stands, as only a light touch of the key
 - no keystroke - is required, thus no adjustment or deformation of the measuring device
- Clear tolerance limits in the scale display and **colored LED signals (red, green, yellow) for measured value classification**
 - **with** warning limit input: No Go / Go / Warning Limit
 - **without** warning limit input: No Go / Go / Rework
- LED signals (red, green, yellow) in mode:
 - powered by Accumulator: flashing signal (1 sec.)
 - powered by data cable DK-U1: permanent
- High contrast LCD display, thus very clear and safe to read
- Analog scale display for visual recognition of the measuring movement during dynamic measurement tasks such as checking
- of concentricity or flatness as well as for reversal point search



Application:
For static and dynamic measuring tasks

TECHNICAL DATA

| Order no. | 4346800 | 4346801 |
|----------------------------------|---------------|--|
| Product type | 2001 W | 2001 Wi |
| Measuring range μm | mm | ± 1 |
| Resolution | mm | 0.0001, 0.0002, 0.0005, 0.001, 0.002, 0.005, 0.01 |
| Resolution | inch | .000005", .00001", .00002", .00005", .0001", .0002", .0005" |
| Error limit | μm | $\pm (0.2 + 0.5 \times L)$ L in mm |
| Measuring value hysteresis f_u | μm | 0.3 |
| Repeatability f_w | μm | 0.1 |
| Norm | | Factory standard |
| Free stroke | mm | 2.5 |
| Measuring force | N | 0.9 ± 0.1 (Reference to absolute zero point of inductive measuring system) |
| Range of analog display | mm | $\pm 0.002, \pm 0.004, \pm 0.01, \pm 0.02, \pm 0.04, \pm 0.1, \pm 0.2$ |
| IP protection category | | IP 64 |
| Supply voltage | | 100– 240 V |

- during bore measurements
- Operating and display unit (bezel) can be rotated through 280°
- Mounting shank and measuring spindle are both made of hardened stainless steel
- Measuring spindle is mounted in a high precision ball guide for minimal hysteresis
- Linearized inductive absolute measuring system
- Measuring force spring is interchangeable
- Lower stop is adjustable
- Software: MarCom Professional free download: www.mahr.com/marcom (only for Mahr data

- cables and wireless systems with USB and RS– 232 interface)
- Digit height: 9 mm
- Data interface: USB, Digimatic
- Energy supply: Integrated rechargeable accumulator (up to 4 weeks) or powered by USB Data Cable
- Battery type: Lithium polymer battery 3.7 V
- Package contains: instruction manual, USB data and charging cable type DK-U1, Plug-in power supply (with 4 interchangeable adapters) for USB, rubber bellows, Screwdriver for pre-stroke adjustment (hexagon socket 0.9 mm), case

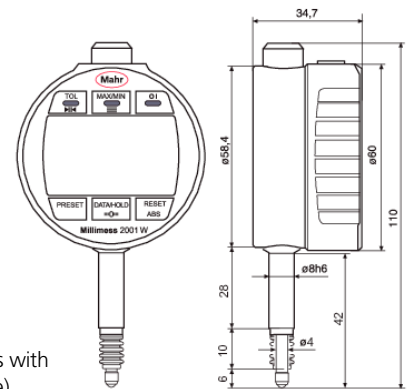

Millimess 2001 W / 2001 Wi

Inductive comparator

ACCESSORIES

| Order no. | Description | Type |
|-----------|---|---------|
| 4102603 | Data cable USB bi-directional (2 m) | DK-U1 |
| 4102606 | Interface adapter with data cable Digimatic (2 m) | DK-D1 |
| 4310103 | Adapter bushing (.375" / 8 mm) | 940 |
| 4346010 | Manual lifter with cable release | 2000 h |
| 4346011 | Pneumatic lifter | 2000 p |
| 4346012 | Measuring force adjuster | 2000 m |
| 4337421 | Lug back | 1086 b |
| 4346050 | Measuring force spring 0.25 N | |
| 4346051 | Measuring force spring 0.50 N | |
| 4882284 | Measuring force spring 0.75 N | |
| 4346052 | Measuring force spring 1.00 N | |
| 4346053 | Measuring force spring 1.50 N | |
| 4346054 | Measuring force spring 2.00 N | |
| 4346055 | Measuring force spring 2.50 N | |
| 4337900 | Display protection film, anti reflective frosted, made of extra hard hybrid glass, to protect against scratches and reflections | 1086 sf |
| 4346606 | Shock protection ring made of hard rubber for Millimess 2000 W(i) / 2001 W(i) | 1086 sr |
| 4102220 | Receiver for instruments with Integrated Wireless | i-Stick |

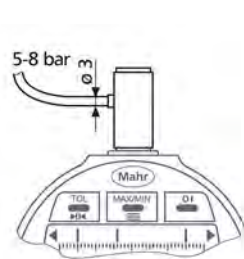

2000 p

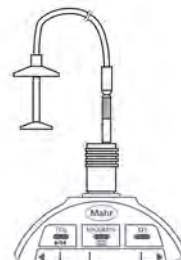

2000 h

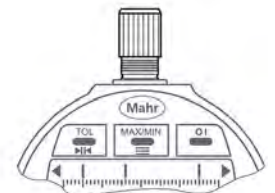

2000 m



1086 sf



1086 sr



i-stick

Millimes 2001 Wi

Inductive comparator



FUNCTIONS

- ON/OFF
- RESET (set display to zero)
- PRESET (for entering a numerical value)
- ABS (reference to the electrical zero point)
- Selectable resolution
- TOL (Tolerance and Warning Limits Input)
- RANGE (switch the measuring range and resolution)
- MAX/MIN memory for searching the reversal point
- (MAX-MIN) for testing flatness and concentricity
- 0 (set the analog scale display to zero)
- Factor (adjustable)
- Reversal of counting direction
- HOLD (storage of measured values)
- LOCK function (key lock)
- DATA (data transmission)
- Bi-directional data interface (external output and input option of characteristic values as well as setting of individual lock functions by software MarCom)

FEATURES

- Unit of measurement METRIC only (no INCH)
- Tempered glass front with touch control panels with enormous advantages:
 - scratch and impact resistant surface
 - excellent protection against dust, coolants and lubricants
 - wear-free touch operating keys
 - improved safety of measurement values in measuring stands, as only a light touch of the key
 - no keystroke - is required, thus no adjustment or deformation of the measuring device
- Clear tolerance limits in the scale display and colored LED signals (red, green, yellow) for measured value classification
 - with warning limit input: No Go / Go / Warning Limit
 - without warning limit input: No Go / Go / Rework
- LED signals (red, green, yellow) in mode:
 - powered by Accumulator: flashing signal (1 sec.)
 - powered by data cable DK-U1: permanent
- High contrast LCD display, thus very clear and safe to read
- Analog scale display for visual recognition of the measuring movement during dynamic measurement tasks such as checking of concentricity or flatness as



Application:

For static and dynamic measuring tasks

Version: Unit of measurement only METRIC (without INCH)

TECHNICAL DATA

| Order no. | | 4346811 |
|----------------------------------|---------------|--|
| Product type | | 2001 Wi |
| Measuring range μm | mm | ± 1 |
| Resolution | mm | 0.0001, 0.0002, 0.0005, 0.001, 0.002, 0.005, 0.01 |
| Error limit | μm | $\pm (0.2 + 0.5 \times L)$ L in mm |
| Measuring value hysteresis f_u | μm | 0.3 |
| Repeatability f_w | μm | 0.1 |
| Norm | | Factory standard |
| Free stroke | mm | 2.5 |
| Measuring force | N | 0.9 ± 0.1 (Reference to absolute zero point of inductive measuring system) |
| Range of analog display | mm | $\pm 0.002, \pm 0.004, \pm 0.01, \pm 0.02, \pm 0.04, \pm 0.1, \pm 0.2$ |
| IP protection category | | IP 64 |
| Supply voltage | | 100– 240 V |

- well as for reversal point search during bore measurements
- Operating and display unit (bezel) can be rotated through 280°
- Mounting shank and measuring spindle are both made of hardened stainless steel
- Measuring spindle is mounted in a high precision ball guide for minimal hysteresis
- Linearized inductive absolute measuring system
- Measuring force spring is interchangeable
- Lower stop is adjustable
- Software: MarCom Professional free download: www.mahr.com/marcom (only for Mahr data

- cables and wireless systems with USB and RS- 232 interface)
- Digit height: 9 mm
- Data interface: Integrated wireless, USB, Digimatic
- Energy supply: Integrated rechargeable accumulator (up to 4 weeks) or powered by USB Data Cable
- Battery type: Lithium polymer battery 3.7 V
- Package contains: instruction manual, USB data and charging cable type DK-U1, Plug-in power supply (with 4 interchangeable adapters) for USB, rubber bellows, Screwdriver for pre-stroke adjustment (hexagon socket 0.9 mm), case

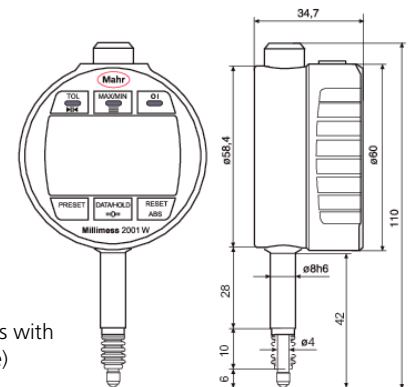

ACCESSORIES

| Order no. | Description | Type |
|-----------|---|---------|
| 4102603 | Data cable USB bi-directional (2 m) | DK-U1 |
| 4102606 | Interface adapter with data cable Digimatic (2 m) | DK-D1 |
| 4310103 | Adapter bushing (.375" / 8 mm) | 940 |
| 4346010 | Manual lifter with cable release | 2000 h |
| 4346011 | Pneumatic lifter | 2000 p |
| 4346012 | Measuring force adjuster | 2000 m |
| 4337421 | Lug back | 1086 b |
| 4346050 | Measuring force spring 0.25 N | |
| 4346051 | Measuring force spring 0.50 N | |
| 4882284 | Measuring force spring 0.75 N | |
| 4346052 | Measuring force spring 1.00 N | |
| 4346053 | Measuring force spring 1.50 N | |
| 4346054 | Measuring force spring 2.00 N | |
| 4346055 | Measuring force spring 2.50 N | |
| 4337900 | Display protection film, anti reflective frosted, made of extra hard hybrid glass, to protect against scratches and reflections | 1086 sf |
| 4346606 | Shock protection ring made of hard rubber for Millimess 2000 W(i) / 2001 W(i) | 1086 sr |
| 4102220 | Receiver for instruments with Integrated Wireless | i-Stick |

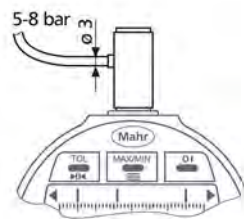

2000 p

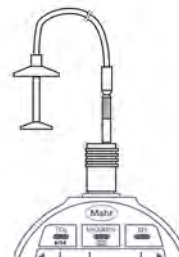

2000 h

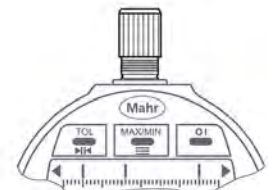

2000 m



1086 sf



1086 sr



i-stick

Mar4D PLQ 4200: Fast and precise measurement during production

The cylinder coordinate measuring machines from the Mar4D PLQ 4200 product line measure rotationally symmetrical workpieces with more flexibility and more conveniently than ever before. They operate at the highest speed and level of precision providing fast and reliable measuring results.

With the Mar4D PLQ 4200, Mahr provides its customers with a high-performance measurement solution for complex rotationally symmetrical workpieces. The multisensor system covers a particularly broad range of dimensional measuring tasks. The new machine also has a particularly sturdy design enabling 3D measurements to be completed directly during production, as well as offering shorter processing times and thus increased throughput and excellent productivity rates.



+ Advantages

- Future-proof thanks to combined measuring technology: optical and tactile solution in one machine
- Versatile: Check several features such as the length, diameter, form, position, contour, roundness, roughness, or 3D geometries, such as the symmetry, during a single measuring run
- Fast and precise: Unique speed and optimum axis accuracy even as the tolerances become smaller achieved thanks to specially developed control architecture
- Flexible for workpieces with a diameter up to 200 mm, a length of up to 1000 mm. and a weight of up to 50 kg
- Ergonomic operation and unique safety concept

Fast alignment

The motorized tailstock with clamping force monitor secures the workpieces perfectly without operator intervention.

Process reliability when measuring

Monitoring systems in the machine record and compensate for external influences, such as temperature, vibrations and position in real-time.

Ergonomic design

The sophisticated design of the machine guarantees easy and safe operation.

Reliable software

Thanks to its clearly structured user interface, the MarWin platform software is very user friendly: learn once, apply again and again.

Universally applicable

The multisensor technology of the Mar4D PLQ 4200 enables measurement of various rotationally symmetrical workpieces directly in production.



Detailed information can be found on our website.
<https://metrology.mahr.com/en/mar4d-plq>

Mar4D PLQ 4200

Cylinder coordinate measuring machine

FEATURES

Fast and precise measurement in production

- Easy to operate
- Process reliability when measuring
- Ergonomic design
- Reliable software
- Universally applicable
- Telecentric precision lens



TECHNICAL DATA

| Order no. | | 5554200 | 5554201 | 5554202 |
|--|---------------|--|-----------------------|--------------------|
| Type | | PLQ 4200-T2 Z=450 | PLQ 4200-T2 Z=730 | PLQ 4200-T2 Z=1000 |
| Dimensions W/H/D | mm | 800 / 2200 / 1800 | 800 / 2500 / 1800 | 800 / 2200 / 1800 |
| Workpiece weight | kg | | max. 20 (optional 50) | |
| Workpiece dimensions | mm | 450 | 730 | 1000 |
| Max. diameter | mm | 200 | | |
| Measurement resolution | | Adjustable | | |
| Lengths/diameters | mm | 0.01...0.0001 | | |
| Lengths/diameters | inch | 0.001...0.0001 | | |
| Angle | | 0.01...0.0001 degrees (decimal) or degrees, minutes, seconds | | |
| Error limit only diameter, $E_{BZX, MPE}^*$ | μm | $\leq (1 + L/150) L$ in mm | | |
| Error limit only parallel length Z, $E_{BZX, MPE}^*$ | μm | $\leq (2 + L/200) L$ in mm | | |
| Travel speed Z | | max. 200 mm/s | | |
| Travel speed X1 | | max. 200 mm/s | | |
| Travel speed X2 | | max. 50 mm/s | | |
| Travel speed C | | max. 2.0 1/s | | |
| Travel speed Y | | max. 50 mm/s | | |

* Tempered workpiece at $t=20 \pm 2^\circ\text{C}$, on smooth surfaces ($R_z < 1 \mu\text{m}$) DIN EN ISO 10360-7

Subject to change without notice.

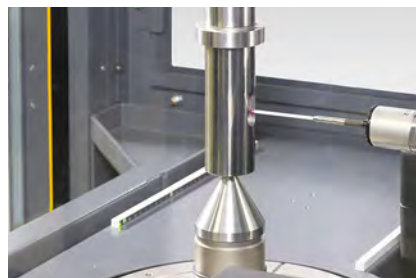

Tactile measurements with SP25



Tactile measurements with T7W



Optical measurements



Control panel

Mar4D PLQ 4200

Cylinder coordinate measuring machine

ACCESSORIES

| Order no. | Description | Type |
|-----------|---|-------|
| 5361112 | Centering tip 60°, Ø 2–15 mm, height 35 mm | |
| 5361223 | Centering tip 60°, Ø 2–44 mm, height 46 mm | |
| 5361105 | Centering tip 60°, Ø 3–15 mm, height 25 mm | |
| 5361106 | Centering tip 60°, Ø 2–19 mm, height 44 mm | |
| 9056631 | Centering tip 60°, Ø 2–35 mm, height 46 mm | |
| 5361104 | Hollow tip 90°, Ø 6–20 mm, height 56 mm | |
| 3026166 | USB keyboard - German | |
| 3026167 | USB keyboard - English | |
| 5550400 | Motorized tactile probe | T7W |
| 5400211 | Probe set | T7W |
| 5550250 | Renishaw tactile probe | SP25M |
| 5550251 | Probe set 1 for SP25 | |
| 5550252 | Probe set 2 for SP25 | |
| 5550083 | MarControl manual control panel | |
| 5550085 | Second monitor plus holder | |
| 5550080 | Housing plus package | |
| 5550084 | Industrial PC | |
| 5550086 | Panel PC included in measuring station scope | |
| 5550091 | Passive, controlled vibration isolation system | |
| 5550100 | MarWin complete package | Mar4D |
| 5550460 | OPTIONAL roughness measurement T7W for PLQ 4200 | |
| 5480638 | Optional roughness software for AdvancedForm | |
| 5360581 | 3D contour standard (without calibration certificate) | |
| 9964316 | Mahr calibration certificate for contour standard | |
| 6980110 | DAkkS / DKD calibration for contour standard | |



Centering tip 60°
Ø 2 – 15 mm



Centering tip 60°
Ø 2 – 44 mm



Centering tip 60°
Ø 3 – 15 mm



Centering tip 60°
Ø 2 – 19 mm



Centering tip 60°
Ø 2 – 35 mm

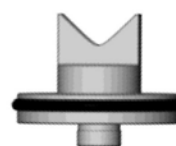

Hollow tip 90°
Ø 6 – 20 mm

MarSurf CD 140 AG 11: All-rounder with intelligent probe system

Mahr has launched a new contour measuring machine on the market – the MarSurf CD 140 AG 11. Its probe system has a measuring range of up to 70 mm and the stylus tips can be replaced quickly and without any tools – without having to recalibrate the system

The new contour measuring machine MarSurf CD 140 AG 11 enables the user to complete fast and precise measurements. Its flexible workpiece holder makes it particularly easy to handle, while users are also convinced by its extreme versatility – it can also be used to measure roughness. The intelligent probe system and magnetic stylus tip holder ensure the process to replace stylus tips without any tools is the most straightforward process to date. Operators can also choose from a comprehensive range of clamps and workpiece holders. The new MarSurf CD 140 AG 11 can be used in a static position or directly at the location of the workpiece.

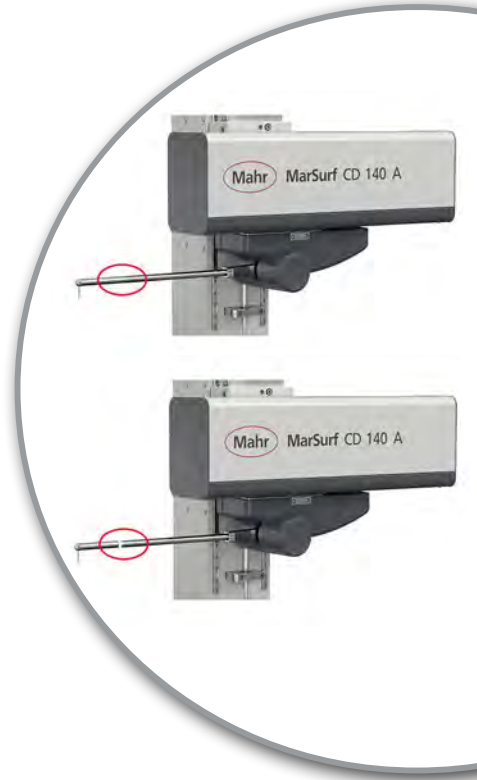

+ Advantages

- Comprehensive contour measurement functions – fast and simple
- Quick adjustment of the Z-axis with handles that are simple to operate
- Replacement of the stylus tip without any tools
- Travel speed in the X-axis of up to 200 mm/s
- Simple program creation or single measurement using MarWin
- Automatic evaluation, best adjustment of contours, CAD contour comparison, and a lot more
- Flexible support plate with 50 mm bore grid for KMG workpiece holder, amongst other
- Optionally expandable with option of roughness measurements ($R_z > 2 \mu\text{m}$)
- Measurement with double stylus

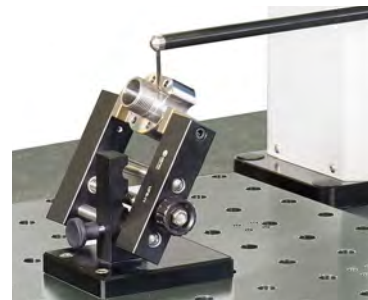

Plug-in guide stops and a wide range of standardized clamping devices as well as workpiece holders enable flexible positioning of your testpiece.

Manual quick adjustment

The fine adjustment is located in the Z-axis and moves the X-axis up and down.

Unique probe system

The probe system with a probe arm length of 350 mm enables a quick change of stylus tips without any tools and without having to recalibrate. The automatic tracing force selection guarantees the correct tracing force is selected when replacing several stylus tips.

X-axis with maximum measuring range

The high-speed X-axis is designed for a large measuring range of 140 mm.

Mahr MarSurf CD 140 A

Support plate also for large components

The 390 mm x 450 mm large plate with 50 mm matrix of holes is also suitable for large-volume workpieces. This provides a variety of flexible clamping options.

Generous traverse path

The Y-axis can be adjusted manually with a traverse path of 60 mm.

Ergonomic carrying handles

The handles on the side make it easy to transport the device.

MarSurf CD 140 AG 11

Contour measuring station

FEATURES

- Fast and precise measurements
- Easy to operate
- Use in a static position or directly at the location of the workpiece
- Manual fine adjustment of the drive unit in the Z-axis
- Stylus tip holder can be used without any tools
- A 390 mm x 450 mm support plate with 50 mm matrix of holes
- High-speed measuring X-axis (140 mm)
- Carrying handles for simple transport
- Quick adjustment of the Z-axis
- Unique adjustment lock secures the adjusted measuring setup
- 350 mm traverse path
- Fast change of stylus tips without tools and without having to recalibrate

Probe system

- Automatic measuring force selection of the correct tracing force when switching between several stylus tips
- Large measuring range – 70 mm
- Probe arm length – 350 mm
- Automated calibration routine for probe arms
- Simple calibration of standard and double probe arms possible
- Simple and repeatable calibration pattern positioning using 50 mm grid
- Magnetic probe arm holder enables probe arm change without tools
- Defined start position
- Aligned axis saving time during preparations

Software

- Simple and intuitive contour measurement and evaluation.
- The measuring assistant will guide you specifically to your measuring data.
- Many measuring tasks – for example for calculating radii, arc lengths, distances, angles etc. – are already pre-programmed for you.
- One particular highlight is the patented “tangential elements” function. This helps evaluate the tangential transitions between radii and straight lines easily and independently of the user.



TECHNICAL DATA

| | |
|------------------------------------|--|
| Order no. | 6269033 |
| Product type | CD 140 AG 11 |
| Positioning speed | 0.1 - 200 mm/s (in X) |
| Tracing distance (in X) end | 140 mm |
| Measuring speed | 0.1 - 10 mm/s |
| Guide deviation | 1 µm / 140 mm |
| Probe arm length | 350 mm |
| Resolution | 19 nm |
| Measuring range in Z | 70 mm |
| Measuring force (N) | 4 mN to 30 mN, in Z+ and Z-, adjustable via software |
| Dimensions (T x B x H) | 572 x 905 x 822 mm |

APPLICATIONS

Mechanical engineering

- Bearings, threads, threaded rods, ball spindles, shafts, racks

Measurements close to production

- Semi-automatic contour measurement

Automotive Industry

- Steering, brake system, transmission, crankshaft, camshaft, cylinder head

Medical technology

- Contour of the hip and knee endoprotheses, contour on medical screws, contour on dental implan



For more information, please visit our website: www.mahr.com

ACCESSORIES

| Order no. | Description | Type |
|-----------|--|------|
| 6820020 | DK accessory box including clamping elements | |
| 6820022 | Quick clamp swivel unit +90° / -55° | |
| 6820023 | Precision three-jaw chuck 50 mm | |
| 6820001 | Vee-block set AF 25 | |
| 6820002 | Delta block set AF 25 | |
| 6820004 | Screw jack set | |
| 9059081 | Precision clamp UZS 15 | |
| 6820000 | Contour standard – contour B for support plate with 50 mm bore dimension | |
| 6820010 | Universal standard holder | |
| 6820125 | Contour standard KN 100 | |
| 6980110 | DAkS/DKD calibration including calibration certificate | |
| 9964316 | Mahr calibration including calibration certificate | |
| 6820003 | Retainer set AF 25 | |
| 6820005 | Manual chuck set, Alufix | |
| 6820021 | Base plate for DK systems | |
| 6820024 | Precision vise 25 mm | |
| 6820025 | Vee-block 90° | |
| 6820026 | Spring compressor with attachment | |
| 6820027 | Quick clamp with 45° angle element | |
| 6820011 | Adapter plate for 50 mm | |
| 9000250 | Centric clamp with spread up to 45 mm | |
| 9000249 | Universal coupling including adapter plate | |
| 9000248 | Parallel vise with spread up to 40 mm | |
| 9026049 | Table plate 740 x 430 set | |



Vee-block set AF 25



Delta block set AF 25



Screw jack set



Precision clamp UZS 15



Contour standard KN 100

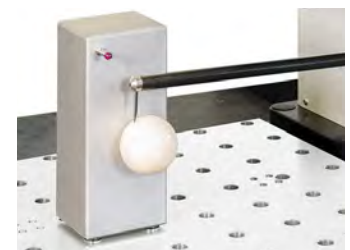

2-sphere calibration standard



For more information, please visit our website: www.mahr.com

Measuring system MFU 200: one machine – **two ultra precise versions**

The proven Mahr MFU measuring system is available in two versions for different applications: MFU 200 for testing form and position of rotationally symmetrical workpieces and MFU 200-3D for measuring components in the optical industry.

MFU has stood for accuracy and stability for many years. Thanks to its universality and ultraprecision it has qualified as a highly precise reference measuring system. The highest measuring certainty increases the tolerance margin for production, optimizes processes, and ultimately reduces production costs.



Advantages of the MFU 200

- High precision thanks to nanometer machine accuracy for workpiece tolerances of 0.5 µm
- Simple to operate providing fast and simple access to the measuring result in just a few seconds – even for a new workpiece
- User-friendly software platform MarWin for form, gear, contour, shaft, roughness – learn once, apply again and again.
- Future-proof thanks to software upgrade options: lead, roughness, contour, chatter marks, Capto, commutators



Additional advantages of the MFU 200-3D

- Equipped with optical IPS sensor and MarOpto clamp set for the qualification of spheres, aspheres, and freeforms in the optical industry
- Clear and user-friendly software platform AsphericLib for measuring and evaluating spheres and aspheres
- Measure freeforms flexibly with the clearly laid-out Aspheric Lib software platform and evaluate them using the Anyshape software
- Optimum performance: Form deviations <100 nm (PV) in 2D and 3D

Maximum precision

The MFU 200 concept ensures accuracy in the nanometer range.

Most reliable repeatability

With an absolute positioning accuracy of 0.001 mm within the space, this provides the best possible reproducibility and process capability.

Measurements without user intervention

The fully automated measuring process with motorized centering and tilting means that user intervention is no longer required thus ensuring process stability.



Shorter measuring times

The high-speed C-axis accelerates the measurements considerably thus increasing productivity.

High-performance checks

The motorized T7W measuring probe and the probe arms arranged in the shape of a star combined tacitly and optically with the IPS sensor allows for flexible scanning and user-friendly operation.

MFU 200

Reference form measuring station

DESCRIPTION

- Reference form measuring station in a new dimension
- The journey from high precision measuring axes to competent measurements is often a long one that the **MFU 200** has mastered completely. Only the **MFU 200** has integrated reference elements for the real-time spatial compensation of geometric deviations, recording all profiles as high precision 3D coordinates.
- For decades, **MarForm** measuring machines have been recognized for their accuracy and stability. The new **MFU 200** was developed with the claims of testing the shape and position features of product parts in a one liter measuring volume close to the production area and at a reasonable cost. In doing so, it has taken our long experience into a new dimension.
- **MFU 200** is a precision reference form measuring center. Its exceptionally low measurement uncertainty increases the tolerance margin for your production processes, thereby lowering production costs.

The form measuring center consists of the following components:

- Circular roundness measuring axis (C)
- Motorized centering and tilting table (X, Y, A, B)
- Roundness measuring axis circular (C- high-speed, up to 200 U/min)
- Vertical straightness measuring axis (Z)
- Horizontal straightness measuring axis (X)
- Tangential multifunction axis (Y)
- Motorized length measuring probe T7W
- MarWin Evaluation Software for form and position features
- The consistent separation of control and evaluation makes **MFU 200** future-proof and expandable. New language versions can be implemented just as effectively as special evaluations and new standards. The **MFU 200** is also already prepared for the use of optical sensor technology, the MarForm IPS, and can thus also measure micro surface structures with high precision.
- In short: **MFU 200** brings form measuring machines for inspection rooms and production areas into a new dimension.



TECHNICAL DATA

| | |
|---------------------------|--|
| Order no. | 5440580 |
| Type | MFU 200 |
| Monitor | 19" TFT monitor (touchscreen monitor) |
| Control panel | MCP 12 |
| Motorized measuring probe | T7W |
| Probe arm | 60 mm ø 1.0, ruby, M2, 60 degrees, prepared for the connection of the optical sensor IPS15 |
| Pitch error | Pitch error of the C-/Z-/X-axis is calibrated |

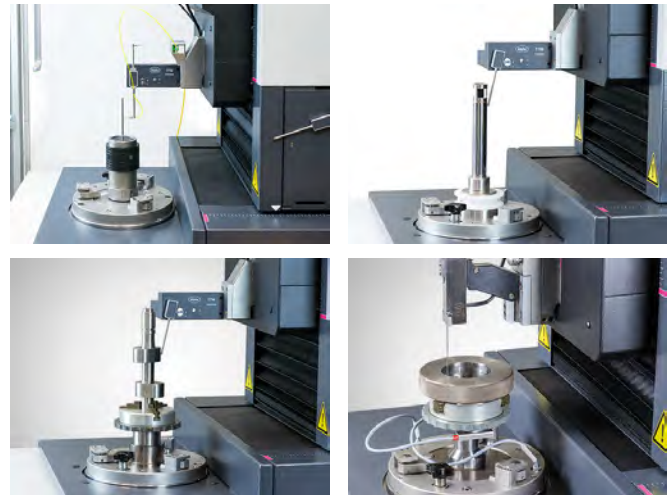

APPLICATIONS

- Checking product parts for form and position features
- Roundness, concentricity / coaxiality, cylindricity, concentricity, axial runout, axial runout, total runout, straightness, parallelism, squareness, inclination, flatness, conicity, diameter, taper, Fourier analysis (waviness analysis), line profile, area profile, cam shape
- Recording of all profiles as high-precision 3D coordinates with real-time
- Spatial compensation of geometric deviations
- Scanning of surfaces, roughness evaluation
- Scanning and evaluation of contours and shapes

ACCESSORIES

| Order no. | Description |
|-----------|--|
| | Hardware (mandatory position):: |
| 9028023 | Calibration sphere Ø 15 mm with Mahr calibration certificate |
| 9064901 | with MarWin PC with WINDOWS 10, multi-lingual |
| 3026857 | Wireless keyboard K400 plus Logitec, German |
| 3026858 | Wireless keyboard K400 plus Logitec, English |
| 6710620 | Three-jaw chuck with flange, Ø 100 mm (NEW VERSION!). not to be used with basic holder |
| 3017216 | Basic holder for quick clamp/retriever interface |
| 9004831 | Rim chuck with three jaws, Ø 50 with column and flange for MFU quick clamp |
| | Software (optional/mandatory position): |
| 5480312 | ProfessionalForm software |
| 5480311 | AdvancedForm software |
| | Optical sensor for MFU 200 plus: |
| 5400275 | Interferometric controller with IPS15, including rack to hold the IPS box |



Three-jaw chuck with column



Calibration sphere



Rim chuck



Rim chuck with collet chucks



For more information, please visit our website: www.mahr.com

MFU 200-3D

High-precision 3D measuring station for spheres, aspheres and freeforms

DESCRIPTION

- The MFU 200-3D is a universal, highly accurate measuring machine for the automatic measurement of spheres, aspheres, freeforms, and special lenses and was developed by Mahr to enable optical components to be tested quickly in 2D and 3D close to the production area.

Accuracy

- With a measurement uncertainty of less than 100 nm PV, the measuring instrument is perfectly designed to meet your process optimization requirements.

Flexibility

- The MFU 200-3D can perform optical and tactile measurements of surfaces. An interferometric point sensor is used for the optical measurement. There is a wide range of probe arms for tactile measurements. Rotationally symmetrical objects with a kurtosis of up to 45°, off-axis and freeforms up to 28° can be measured.



TECHNICAL DATA

| Order no. | 5440581 |
|--------------------------------------|--|
| Type | MFU 200-3D |
| Monitor | 19" TFT monitor (touchscreen monitor) |
| Control panel | MCP 12 |
| Motorized measuring probe | T7W |
| Optical measuring probe | IPS |
| Probe arm | 90° angled, ruby ball ø 3mm, incl. connection for optical sensor |
| Pitch error | Pitch error of the C-/Z-/X-axis is calibrated |
| Calibration set and Basic clamp set | included |
| MFU 200-3D Aspheric software package | included |
| MFU 200-3D Anyshape software option | optional |

ACCESSORIES

| Order no. | Description |
|-----------|--|
| 5440468 | Hydraulic expansion chuck ø 25 mm for quick clamp system |
| 5440471 | Three-jaw chuck for quick clamp system |
| 5440472 | Vise for quick clamp system |
| 5440473 | Index plate for quick clamp system |
| 5440474 | Mounting plate |
| 3028108 | Adapter for hydraulic expansion chuck 25 mm – 12 mm |
| 9058047 | Clamps for 200 mm lenses |

Clamp set

Universal design for every purpose – the design ensures you are well equipped even if you have a broad range of components.

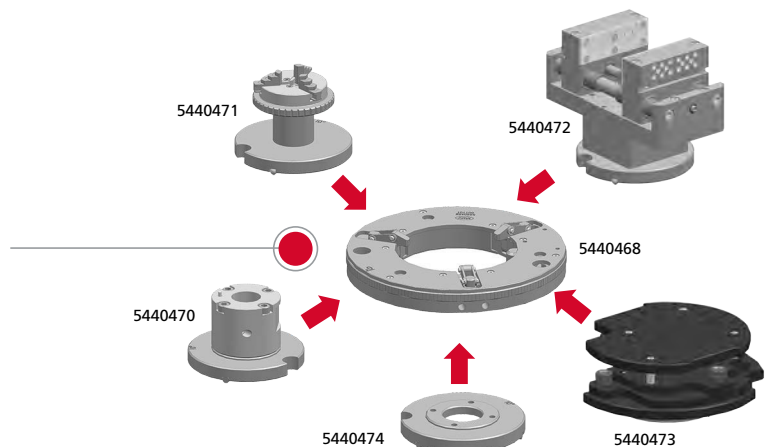

MFU 200-3D

High-precision 3D measuring station for spheres, aspheres and freeforms

Advantages:

- Automatic tilting and centering – user-independent positioning, centering, and alignment of measuring objects
- Active tracking – automatic measurement of unknown geometries; the sensor (optical and tactile) automatically follows the surface via the machine controller
- Probe combination – combination of optical sensors and tactile probes can be combined in one probe system; can be moved in space (360°)
- Closed loop integration in the production process (grinding/polishing) perfect for transmissive optics (tilt/centering error designation)



MEASURING TASKS & SOFTWARE

Flexible measuring tasks in one machine

- Form
- Contour
- Roughness
- Axis offset of lenses
- Radial runout error
- Tilt and centering error of the optics

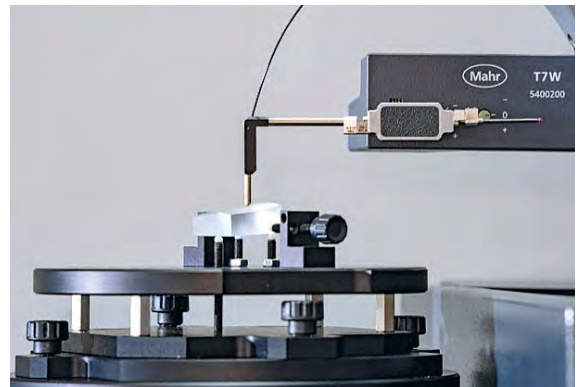

SOFTWARE

Special software package for your requirements

- AsphericLib software for measuring and evaluating spheres and aspheres
- SW analysis of the tool for the future – freeform measurement and evaluation

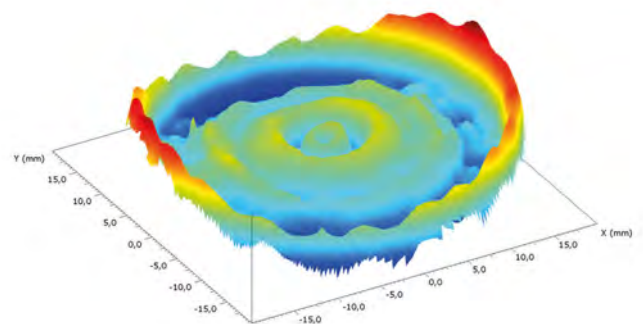

For more information, please visit our website: www.mahr.com



Mahr GmbH
Carl-Mahr-Straße 1
37073 Göttingen
Germany

Reutlinger Straße 48
73728 Esslingen
Germany

Tel.: +49 551 7073 800
info@mahr.com
www.mahr.com

© Mahr GmbH

We reserve the right to make changes to our products,
especially due to technical improvements and further developments.
All illustrations and technical data are therefore subject to change.

3765844 | 04.2022



Diverse and innovative – our new products for 2023



Contents

| | |
|---------------------------------------|-----------|
| Overview myMahr portal | 4 |
| myMahr Monitoring & Assets | 6 |
| Online shop | 8 |
| Overview MarCal | 10 |
| MarCal 30 EWri / 30 EWR | 12 |
| Digital depth gage | |
| MarCal 30 EWri-D / 30 EWR-D | 13 |
| Digital depth gage | |
| Overview Millimar | 14 |
| Millimar P2002 M / P2002 T | 15 |
| Inductive measuring probe | |
| Millimar P2002 MA / P2002 TA | 16 |
| Inductive measuring probe | |
| Millimar P2002 MB / P2002 TB | 17 |
| Inductive measuring probe | |
| Overview MarSurf M 410 | 18 |
| MarSurf M 410 | 22 |
| Mobile surface measuring instrument | |
| Overview MarSurf M 410 PC | 24 |
| MarSurf M 410 PC | 26 |
| Surface measuring station | |
| Overview Mahr Feeder | 28 |
| Overview Mar4D PLQ | 30 |

The new myMahr portal: Everything in one place

In the future, you as a Mahr customer will benefit from the new digital service platform: The myMahr portal centrally combines all of the interfaces between you and us in a clear and user-friendly way. The only prerequisites for accessing the personalized digital services are an Internet connection and an initial registration.

Our myMahr portal will make it considerably easier for you to complete all of the work relating to measuring tasks. This is because it combines all of the important information about the measuring technology in your production department. At a glance, you can thus quickly and accurately determine if the performance in the measuring room is correct and where you can make optimizations. In addition, you can simply and easily order products, spare parts, and accessories directly online. If you should ever require our support, you can contact Mahr quickly via the platform.

The myMahr portal has four functions for you:

- 1 Monitoring & Assets
- 2 Online Shop & Order Status
- 3 Services
- 4 Training

In the near future, we will be adding further convenient services to the myMahr portal, which will further simplify and support your quality assurance processes. Initially, the platform will be available to customers in Germany, Austria, and Switzerland before we make it available globally.

Contemporary online shopping

Our new online shop is available 24/7 providing you with a quick and clear overview of all of the required accessories and spare parts at a best price guarantee.

Your request – our job

Direct contact to our Service team, including the option of remote access, ensures you receive support quickly.

Quality assurance of the future

Here you can access your virtual measuring room including the measuring data and performance in real-time, and all of the relevant documents.

Metrology expertise

You can easily book your professional training, training courses, and seminars here and attend them online.



Services



Shop &
Order Status

myMahr



Trainings



Monitoring
& Assets



Advantages

- Intuitive to operate thanks to clear user guidance
- Measuring room performance at a glance
- Direct contact to the Mahr Service team
- Connection to our own online shop

Full control: All measurement solutions at a glance

We provide the Monitoring & Assets area in the myMahr portal to ensure you always know what and how everything is running in your measuring room. It is designed to be a control center for your measuring machines and as an archive for all of the relevant documents. This is an important step towards automating quality assurance processes.

The prerequisite for being able to use the full scope of Monitoring & Assets functions, is registering the machines at "myMahr ready". During this process, we will record the hardware and software status of all of your Mahr measurement solutions and integrate this data in the asset management feature. You can then organize and arrange your measurement solutions within the asset management in accordance with your individual requirements, for example, according to the different measuring rooms.



Advantages

- Automatic integration of your hardware and software data following registration on **myMahr ready**
- Status and performance machine data in real-time
- Condition monitoring and predictive maintenance will be available in the future
- Order accessories and spare parts quickly and easily in the online shop



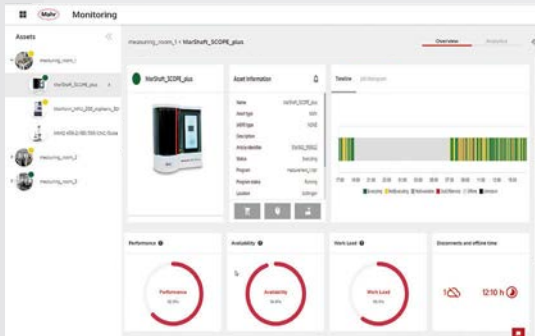

Live data: **Monitoring**

The heart of myMahr Monitoring & Assets is the monitoring function. It provides you with the opportunity to transfer and evaluate live data from measuring stations – an Internet connection is a prerequisite. A dashboard provides a clearly structured overview of the status and utilization of your measuring machines and includes the most important figures about the overall equipment effectiveness (OEE). This currently only applies to Mahr machines. However, in future the OPC UA interface standard should make it possible to also integrate machines from other manufacturers.

The screenshot shows a 'New Service Request' form. It contains input fields for 'Contact Name', 'Contact Number', and 'Email'. There is a 'Detailed Description*' text area and an 'Upload file' button. A 'Reason*' dropdown menu is set to 'Please choose'. A checkbox for data storage consent is present. At the bottom, there are 'Cancel' and 'Send request' buttons.

Machine status: **Service status**

In addition, myMahr Monitoring & Assets will in the future be able to offer you condition monitoring and predictive maintenance. This means you will automatically receive information about the status and service status of your measuring machines so that you can contact Mahr Service sufficiently in advance. You can also order any spare parts or accessories you require easily at any time via our online shop, which is also available in the myMahr portal.

| Document Name | Type | Language | Asset ID | Date | Status |
|---------------------|-------------------|----------|----------------------|------------------|------------------|
| Service_2020_01.pdf | Service documents | German | 10000000000000000000 | 01.01.2020 10:00 | Visible Document |
| Service_2020_02.pdf | Service documents | English | 10000000000000000000 | 01.01.2020 10:00 | Visible Document |
| Service_2020_03.pdf | Service documents | English | 10000000000000000000 | 01.01.2020 10:00 | Visible Document |
| Service_2020_04.pdf | Service documents | English | 10000000000000000000 | 01.01.2020 10:00 | Visible Document |
| Service_2020_05.pdf | Service documents | English | 10000000000000000000 | 01.01.2020 10:00 | Visible Document |
| Service_2020_06.pdf | Service documents | English | 10000000000000000000 | 01.01.2020 10:00 | Visible Document |
| Service_2020_07.pdf | Service documents | English | 10000000000000000000 | 01.01.2020 10:00 | Visible Document |
| Service_2020_08.pdf | Service documents | English | 10000000000000000000 | 01.01.2020 10:00 | Visible Document |
| Service_2020_09.pdf | Service documents | English | 10000000000000000000 | 01.01.2020 10:00 | Visible Document |
| Service_2020_10.pdf | Service documents | English | 10000000000000000000 | 01.01.2020 10:00 | Visible Document |
| Service_2020_11.pdf | Service documents | English | 10000000000000000000 | 01.01.2020 10:00 | Visible Document |
| Service_2020_12.pdf | Service documents | English | 10000000000000000000 | 01.01.2020 10:00 | Visible Document |

Digital archive: **Documents**

You can also access all of the documents relating to your measuring solutions in myMahr Monitoring & Assets, including operating instructions, calibration certificates, or sales documents such as quotations and delivery slips.

Contemporary online shopping for business customers

Start of our new online shop: With this innovative platform, we are offering you an efficient business-to-business solution to meet your specific requirements as a corporate client. The online shop comprises many practical functions and offers you a comprehensive range of benefits.

An intuitive and user-friendly design guarantees a pleasant shopping experience. You can easily select the right product from a very broad product portfolio that includes hand-held measuring tools, accessories, and spare parts for complex measurement solutions. They are easy to find using the high-performance faceted search function that filters products by their features or using the fast entry screen for the item number. A traffic light system indicates the availability of the relevant item. The online shop also provides important additional information about the individual products, including the measuring range, technical specifications, or drawings.

Customer focus, even for payments: Quick purchases, including payment by credit card or PayPal, can be processed as guest orders without having to register. Registered purchasers with a customer account benefit from many additional advantages. They can, for example, place recurring orders as the customer account saves previous purchases. As our online shop is also optimized for all mobile end devices, you or your measurement engineer can access it from anywhere and order the required products. Overall, we hope that our online shop will improve your purchasing processes and further increase your competitive position.



Advantages

- Simple online shopping with modern user interface
- Accurate and simple searches for required items
- Flexible payment options
- View order status and invoices online
- Additional services for registered customers

Select specific product area

The detailed dropdown menu enables purchasers to quickly access the right product category.



Quick order as a guest

Even without registering, you can make a purchase using a credit card or PayPal.

Logon for existing customers

Registered customers can log in and access their order history, for example.

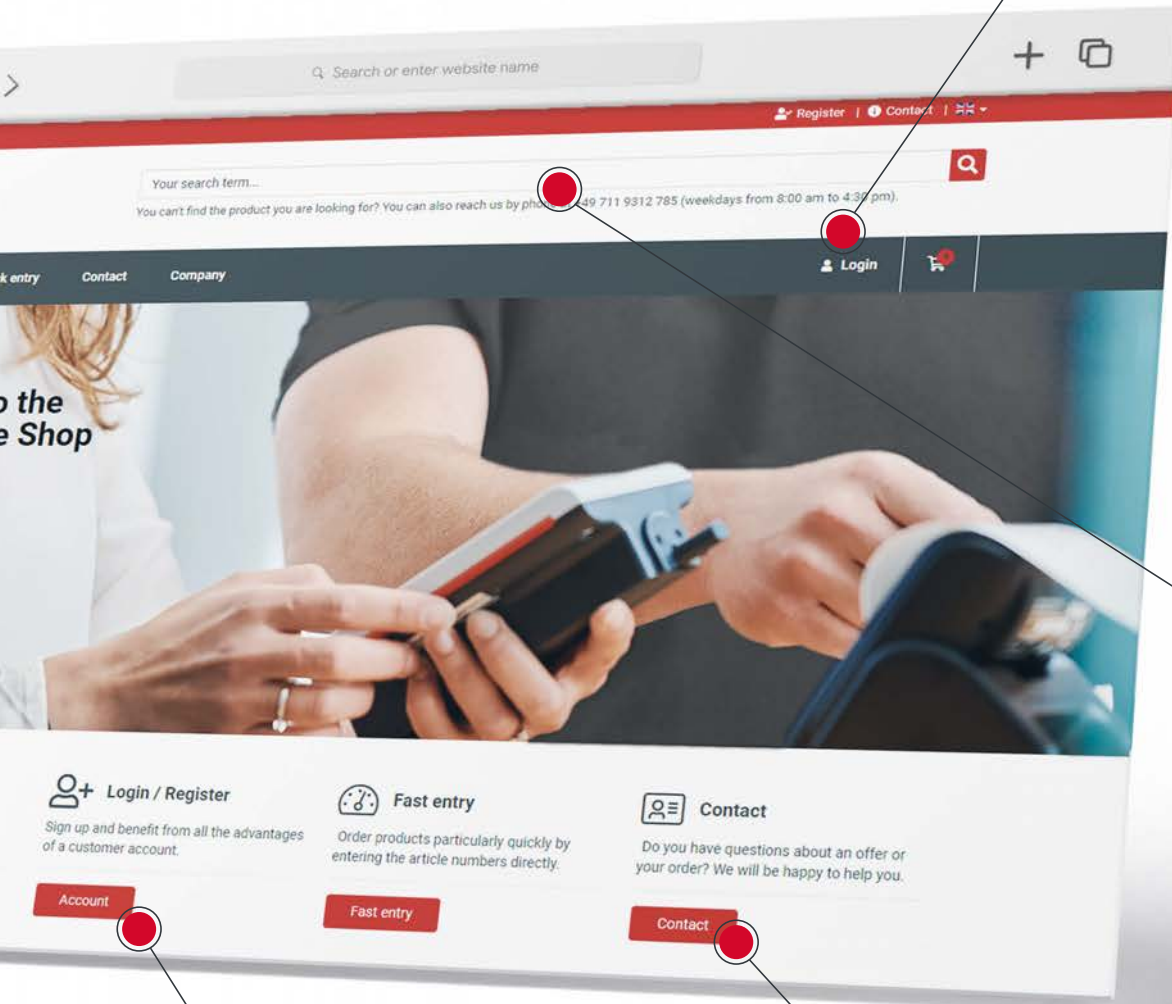

Efficient search

Products can be found very quickly using the search function.

Get in touch

If you have any questions, it is easy to contact MAHR.

Simply register

Anyone who wishes to benefit from all the advantages a user account has to offer, can simply register.

The new Mahr online shop is here:

<https://shop.mahr.com/DE-en/>



The new depth gage for maximum process safety

Measurements are even safer and more efficient using the MarCal 30 EWRI caliper that is more reliable than ever. Thanks to the Integrated Wireless function, you can also transfer your measurement results to all Windows applications at the touch of a button.

Reliable measuring equipment, that can be used flexibly, is essential in the production and quality assurance departments. Mahr has developed this new caliper to help you ensure your measurements achieve an even higher level of process safety and efficiency. In addition to our tried and tested features, such as the practical Integrated Wireless function for wireless measurements, we have focused on providing the best possible flexibility at the workstation. Practical accessories, as well as other useful special designs, offer you a variety of measurement equipment and tools with which you can increase your daily level of efficiency.

Ergonomic, workshop-focused design

Even in dirty environments or poor lighting conditions, you can still read off the numbers thanks to the high-contrast 11 mm font. The ergonomic housing makes it easy to handle thus providing safe measuring results.



Advantages

- Wireless data transfer and free MarCom Professional software
- Hardened stylus element for universal contact even in tight measuring points
- Measurements with a wide measuring surface
- Lapped guide rails ensure the slide runs evenly and smoothly
- Protection rating IP 67 for use in all workshop conditions
- Practical accessories, e.g. long measuring bridges to cover large distances
- Additional model type 30 EWRI-D with twin hook to measure depths, distances, and widths



Two measuring surfaces

Perfect for your measuring task, including universal stylus or wide transverse measuring surface – the stylus can be removed for this purpose.

3 Up to 3 years
battery life

Integrated Wireless

Take measurements completely autonomously without data cables getting in the way and benefit from recording data quickly and safely without the risk of incorrect manual entries. The displayed measured value is wirelessly transferred directly to your Windows application at the touch of a button.

Extra narrow rail cross-section

The particularly narrow rail cross-sections (12 x 3.5 mm) above all enable you to measure narrow measuring points in more detail, while the lightweight design of the caliper makes it easier to handle.

Practical accessories: long measuring bridges 30 EXm

If it does not fit, it can be adjusted. We provide long measuring bridges (300 and 400 mm) to place over and cover distances. Installation is simple and can be adjusted within the hole grid, ensuring you can reach your measuring point even if there are greater distances between the points.



MarCal 30 EWRI / 30 EWR

Digital depth gage

FUNCTIONS

Functions 30 EWRI:

- ON/OFF
- AUTO-ON / OFF
- RESET (set display to zero)
- mm/inch
- PRESET (for entering a numerical value)
- LOCK function (key lock)
- HOLD (storage of measured values)
- Reversal of counting direction
- DATA (data transmission)

30 EWRI



Functions 30 EWR:

- AUTO-ON / OFF
- DATA (data transmission via connection cable)
- ON/OFF
- PRESET (for entering a numerical value)
- RESET (set display to zero)
- mm/inch
- LOCK function (key lock)
- High contrast digit display
- Locking screw above
- Lapped guideway
- Measuring surfaces made of steel
- Slide and beam made of hardened stainless steel
- Immediate measurements due to the Reference System
- Raised guideway for the protection of the scale
- Excellent resistance against dust, coolants and lubricants
- Dirt wipers are integrated in the slide

30 EWR



FEATURES 30 EWRI:

- **Digit height:** 11 mm
- **Data interface:** Integrated Wireless
- **Energy supply:** Battery life approx. 3 years (approx. 0.5 in wireless mode)
- **Battery type:** CR 2032 (3V Lithium)
- **IP protection category:** IP 67
- **Package contains:** battery, test certificate, instruction manual, case

FEATURES 30 EWR:

- **Digit height:** 8.5 mm
- **Data interface:** USB, Opto RS-232C, Digimatic
- **Energy supply:** Battery life approx. 3 years
- **Battery type:** CR 2032 (3V Lithium)
- **IP protection category:** IP 67
- **Package contains:** battery, test certificate, instruction manual, case

TECHNICAL DATA

| Order no. | Type | Measuring range | Measuring range | Resolution | Error limit | Standard |
|-----------|---------|-----------------|-----------------|---------------|-------------|-------------|
| | | mm | inch | mm/inch | mm | |
| 4126671 | 30 EWRI | 0-150 | 0-6" | 0.01 / .0005" | 0.03 | ISO 13385-2 |
| 4126672 | 30 EWRI | 0-200 | 0-8" | 0.01 / .0005" | 0.03 | ISO 13385-2 |
| 4126673 | 30 EWRI | 0-300 | 0-12" | 0.01 / .0005" | 0.04 | ISO 13385-2 |
| 4126674 | 30 EWRI | 0-500 | 0-20" | 0.01 / .0005" | 0.05 | ISO 13385-2 |
| 4126651 | 30 EWR | 0-150 | 0-6" | 0.01 / .0005" | 0.03 | ISO 13385-2 |
| 4126652 | 30 EWR | 0-200 | 0-8" | 0.01 / .0005" | 0.03 | ISO 13385-2 |
| 4126653 | 30 EWR | 0-300 | 0-12" | 0.01 / .0005" | 0.04 | ISO 13385-2 |
| 4126654 | 30 EWR | 0-500 | 0-20" | 0.01 / .0005" | 0.05 | ISO 13385-2 |

| Order no. | a | b | Rail cross-section |
|-----------|-----|-----|--------------------|
| | mm | mm | mm |
| 4126671 | 230 | 100 | 12 x 3.5 |
| 4126672 | 280 | 100 | 12 x 3.5 |
| 4126673 | 382 | 150 | 12 x 3.5 |
| 4126674 | 586 | 150 | 12 x 3.5 |
| 4126651 | 230 | 100 | 12 x 3.5 |
| 4126652 | 280 | 100 | 12 x 3.5 |
| 4126653 | 382 | 150 | 12 x 3.5 |
| 4126654 | 586 | 150 | 12 x 3.5 |

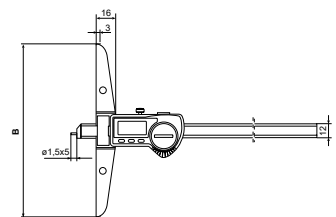

ACCESSORIES

| Order no. | For measuring instrument | Description | Quantity | unit | Type |
|-----------|--------------------------|---|----------|------|---------|
| 4102220 | 30 EWRI | Receiver for instruments with Integrated Wireless | | | i-Stick |
| 4102357 | 30 EWR | Data connection cable USB (2 m) | | | 16 EXu |
| 4102410 | 30 EWR | Data connection cable RS232C (2 m) | | | 16 EXr |
| 4102915 | 30 EWR | Interface adapter with data cable Digimatic (2 m) | | | 16 EWd |
| 4125611 | 30 EWRI, 30 EWR | Anvil (4 mm) | Piece | | 30 ESa |
| 4126510 | 30 EWRI, 30 EWR | Cross beam extension (300 mm) | | | 30 EXm |
| 4126511 | 30 EWRI, 30 EWR | Cross beam extension (200 mm) | | | 30 EXm |

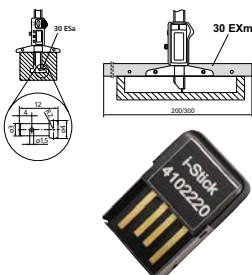

MarCal 30 EWri-D / 30 EWR-D

Digital depth gage

FUNCTIONS



Functions 30 EWR-D:

- High contrast digit display
- Locking screw above
- Lapped guideway
- Measuring surfaces made of steel
- Slide and beam made of hardened stainless steel
- Immediate measurements due to the Reference System
- Raised guideway for the protection of the scale
- Excellent resistance against dust, coolants and lubricants
- Dirt wipers are integrated in the slide



30 EWri-D



FEATURES 30 EWri-D:

- **Digit height:** 11 mm
- **Data interface:** Integrated Wireless
- **Energy supply:** Battery life approx. 3 years (approx. 0.5 in wireless mode)
- **Battery type:** CR 2032 (3V Lithium)
- **IP protection category:** IP 67
- **Package contains:** battery, test certificate, instruction manual, case



30 EWR-D

Application:

Measuring groove widths and distances between grooves

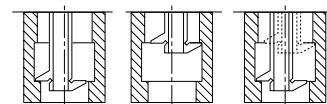

FEATURES 30 EWR-D:

- **Digit height:** 8.5 mm
- **Data interface:** USB, Opto RS-232C, Digimatic
- **Energy supply:** Battery life approx. 3 years
- **Battery type:** CR 2032 (3V Lithium)
- **IP protection category:** IP 67
- **Package contains:** battery, test certificate, instruction manual, case

TECHNICAL DATA

| Order no. | Type | Measuring range | | Resolution | Error limit | Standard |
|-----------|-----------|-----------------|---------|---------------|-------------|-------------|
| | | mm | inch | | | |
| 4126535 | 30 EWri-D | 0 – 200 | 0 – 8" | 0.01 / .0005" | 0.03 | ISO 13385-2 |
| 4126536 | 30 EWri-D | 0 – 300 | 0 – 12" | 0.01 / .0005" | 0.04 | ISO 13385-2 |
| 4126525 | 30 EWR-D | 0 – 200 | 0 – 8" | 0.01 / .0005" | 0.03 | ISO 13385-2 |
| 4126526 | 30 EWR-D | 0 – 300 | 0 – 12" | 0.01 / .0005" | 0.04 | ISO 13385-2 |

| Order no. | a | b | c | Rail cross-section |
|-----------|-----|-----|----|--------------------|
| | mm | mm | mm | mm |
| 4126535 | 289 | 100 | 12 | 12 x 3.5 |
| 4126536 | 391 | 150 | 12 | 12 x 3.5 |
| 4126525 | 289 | 100 | 12 | 12 x 3.5 |
| 4126526 | 391 | 150 | 12 | 12 x 3.5 |

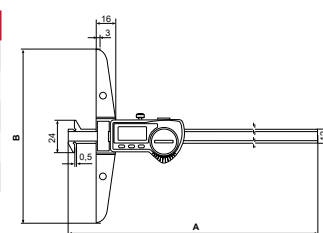

ACCESSORIES

| Order no. | For measuring instrument | Description | Type |
|-----------|--------------------------|---|---------|
| 4102220 | 30 EWri-D | Receiver for instruments with Integrated Wireless | i-Stick |
| 4102357 | 30 EWR-D | Data connection cable USB (2 m) | 16 EXu |
| 4102410 | 30 EWR-D | Data connection cable RS232C (2 m) | 16 EXr |
| 4102915 | 30 EWR-D | Interface adapter with data cable Digimatic (2 m) | 16 EWD |
| 4126510 | 30 EWri-D, 30 EWR-D | Cross beam extension (300 mm) | 30 EXm |
| 4126511 | 30 EWri-D, 30 EWR-D | Cross beam extension (200 mm) | 30 EXm |

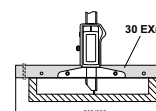

New addition with **best possible linearity and precision**

A new inductive probe has been added to the Millimar range: The P2002 will simplify your measurements, regardless of whether you are measuring the conicity, concentricity, radial runouts, thickness, or diameter. The measuring probe records measured values and deviations reliably and can be used for a variety of applications.

Usually, lengths cannot be recorded linearly over the entire measuring path using an inductive probe. This is not the case with our new all-rounder – the Millimar P2002 – that offers a high level of linearity because of its perfectly coordinated measurement system.

The probe provides a maximum level of measurement accuracy and minimal linearity deviations across the entire measuring range. A revised ball-bearing guide also offers a highly accurate and easy guide.

The excellent electromagnetic shielding provides a high level of protection against external magnetic fields. It can also be used in areas close to production and is available in all leading compatibilities.



Advantages

- Highly accurate, linear probe for diameters, radial runouts, thicknesses and much more
- Universal use in the measuring room or production
- New ball-bearing guide offers highly accurate and easy handling
- Reliable EMC shielding to protect against external magnetic fields



Millimar P2002

The new P2002 plays to its strengths in all applications where you need to check the length: From brake disks and mobile phone covers through to turbine blades, the new Millimar sensor is a real all-rounder.



FEATURES

- Variant without and with pneumatic lifter or load
- Measuring pin mounted in rotary stroke bearing
- High linearity over the entire measuring range
- Excellent electromagnetic shielding (EMC)
- All probes can be easily converted from axial to radial by mounting a slip on cap, included in the scope of supply
- Chemical resistance data: resistant to oil, gasoline, water and aliphatic compounds. Moderately resistant to acids, bases, solvents and ozone
- **Package contains:** test certificate, instruction manual, cap for radial cable output, spanner for preliminary stroke setting



TECHNICAL DATA

| | Order no. | 5323210 | 5323211 |
|----------------------------------|-----------|----------------------------|---------|
| Type | | P2002 M | P2002 T |
| Measuring range | mm | ± 1 | |
| Distance to upper stop | mm...mm | 1.2 . . . 2.4 | |
| Distance to lower stop | mm...mm | -1.2 . . . 0 | |
| Lifter / retraction | | Standard model | |
| Measuring force | N | 0.75 N +/- 0.15 N | |
| Sensitivity deviation | % | 0.3 | |
| Repeatability f_w | µm | 0.1 | |
| Measuring value hysteresis f_u | µm | 0.3 | |
| Error limit | µm | 0.1 + 0.8 x L ³ | |
| IP protection category | | IP 64 | |
| Cable length | m | 2.5 | |
| Temperature coefficient | µm/°C | 0.15 | |
| Compatibility | | Mahr-VLDT | Tesa |

| Order no. | a | b | c | d | e | f | h | Connection thread |
|-----------|------|----|------|----|-----|----|----|-------------------|
| 5323210 | mm | mm | mm | mm | mm | mm | mm | M 2.5 |
| 5323211 | 88.7 | 28 | 21.3 | 6 | 9.2 | 8 | 14 | M 2.5 |

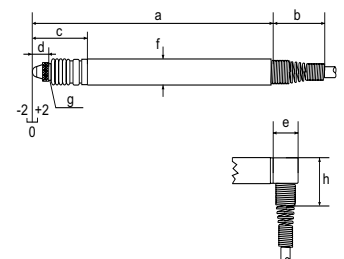

FEATURES

- Variant without and with pneumatic lifter or load
- Measuring pin mounted in rotary stroke bearing
- High linearity over the entire measuring range
- Excellent electromagnetic shielding (EMC)
- All probes can be easily converted from axial to radial by mounting a slip on cap, included in the scope of supply
- Chemical resistance data: resistant to oil, gasoline, water and aliphatic compounds. Moderately resistant to acids, bases, solvents and ozone
- **Package contains:** test certificate, instruction manual, cap for radial cable output, spanner for preliminary stroke setting



TECHNICAL DATA

| Order no. | 5323220 | 5323221 |
|----------------------------------|------------------------------|------------------------|
| Type | P2002 MA | P2002 TA |
| Measuring range | mm | ± 1 |
| Distance to upper stop | mm...mm | 1.2 . . . 2.4 |
| Distance to lower stop | mm...mm | -1.2 . . . 0 |
| Lifter / retraction | | Vacuum lifter |
| Measuring force | N | 0.75 N +/-0.15 N |
| Increase in measuring force | N/mm | 0.2 N/mm |
| Sensitivity deviation | % | 0.3 |
| Repeatability f_w | μm | 0.1 |
| Measuring value hysteresis f_u | μm | 0.3 |
| Error limit | μm | $0.1 + 0.8 \times L^3$ |
| IP protection category | | IP 64 |
| Cable length | m | 2.5 |
| Temperature coefficient | $\mu\text{m}/^\circ\text{C}$ | 0.15 |
| Compatibility | | Mahr-VLDT Tesa |

| Order no. | a | b | c | d | e | f | h | i | j | k | l | m | Connection thread |
|-----------|------|----|------|----|-----|----|----|------|-----|----|-----|------|-------------------|
| | mm | mm | mm | mm | mm | mm | mm | mm | mm | mm | mm | mm | |
| 5323220 | 88.7 | 28 | 21.3 | 6 | 9.2 | 8 | 14 | 26.5 | 3.6 | 9 | 8.3 | 12.5 | M 2.5 |
| 5323221 | 88.7 | 28 | 21.3 | 6 | 9.2 | 8 | 14 | 26.5 | 3.6 | 9 | 8.3 | 12.5 | M 2.5 |

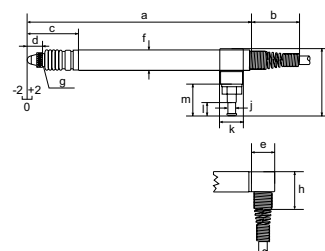

FEATURES

- Variant without and with pneumatic lifter or load
- Measuring pin mounted in rotary stroke bearing
- High linearity over the entire measuring range
- Excellent electromagnetic shielding (EMC)
- All probes can be easily converted from axial to radial by mounting a slip on cap, included in the scope of supply
- Chemical resistance data: resistant to oil, gasoline, water and aliphatic compounds. Moderately resistant to acids, bases, solvents and ozone
- **Package contains:** test certificate, instruction manual, cap for radial cable output, spanner for preliminary stroke setting



TECHNICAL DATA

| Order no. | 5323230 | 5323231 |
|----------------------------------|--|----------|
| Type | P2002 MB | P2002 TB |
| Measuring range | ± 1 | |
| Distance to upper stop | 1.2 ... 2.4 | |
| Distance to lower stop | -1.2 ... 0 | |
| Lifter / retraction | Compressed air retraction (max. 1 bar) | |
| Measuring force | Dependent on compressed air | |
| Sensitivity deviation | 0.3 | |
| Repeatability f_w | 0.1 | |
| Measuring value hysteresis f_u | 0.3 | |
| Error limit | 0.1 + 0.8 x L ³ | |
| IP protection category | IP 64 | |
| Cable length | 2.5 | |
| Temperature coefficient | 0.15 | |
| Compatibility | Mahr-VLDT | Tesa |

| Order no. | a | b | c | d | e | f | h | i | j | k | l | m | Connection thread |
|-----------|------|----|------|----|-----|----|----|------|-----|----|-----|------|-------------------|
| | mm | mm | mm | mm | mm | mm | mm | mm | mm | mm | mm | mm | |
| 5323230 | 88.7 | 28 | 21.3 | 6 | 9.2 | 8 | 14 | 26.5 | 3.6 | 9 | 8.3 | 12.5 | M 2.5 |
| 5323231 | 88.7 | 28 | 21.3 | 6 | 9.2 | 8 | 14 | 26.5 | 3.6 | 9 | 8.3 | 12.5 | M 2.5 |

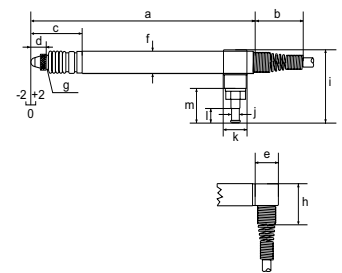

ACCESSORIES

| Order no. | For measuring instrument | Description | Type |
|-----------|--------------------------------------|--|---------|
| 5313419 | P2002 MA, P2002 TA | Pneumatic foot switch for max. 4 probes | 1340/1F |
| 5313420 | P2002 MA, P2002 TA | Pneumatic hand lifter for 1 probe | 1340/1 |
| 5323130 | P2002 MA, P2002 MB, P2002 M | Extension cable 2.5 m (Mahr VLDT) | C2025 M |
| 5323131 | P2002 T, P2002 TB, P2002 TA | Extension cable 2.5 m (Tesa) | C2025 T |
| 5323140 | P2002 MA, P2002 MB, P2002 M | Extension cable 5 m (Mahr VLDT) | C2050 M |
| 5323141 | P2002 T, P2002 TB, P2002 TA | Extension cable 5 m (Tesa) | C2050 T |
| 5323150 | P2002 MA, P2002 MB, P2002 M | Extension cable 7.5 m (Mahr VLDT) | C2075 M |
| 5323151 | P2002 T, P2002 TB, P2002 TA | Extension cable 7.5 m (Tesa) | C2075 T |
| 5323160 | P2002 MA, P2002 MB, P2002 M | Extension cable 10 m (Mahr VLDT) | C2100 M |
| 5323161 | P2002 T, P2002 TB, P2002 TA | Extension cable 10 m (Tesa) | C2100 T |
| 7021546 | P2002 T, P2002 MA, P2002 M, P2002 TA | Sealing bellows for probes with measuring spring | |
| 7025505 | P2002 T, P2002 MA, P2002 M, P2002 TA | Measuring spring 1.25 N | |
| 7025579 | P2002 T, P2002 MA, P2002 M, P2002 TA | Measuring spring 1.0 N | |
| 7026827 | P2002 T, P2002 MA, P2002 M, P2002 TA | Measuring spring 0.25 N | |
| 7026828 | P2002 T, P2002 MA, P2002 M, P2002 TA | Measuring spring 0.5 N | |
| 7026849 | P2002 T, P2002 MA, P2002 M, P2002 TA | Measuring spring 0.75 N | |
| 7028220 | P2002 TB, P2002 MB | Sealing bellows for probes with air retraction | |

Simple, innovative, flexible – modern surface metrology to be used by hand

Mobile recording and evaluation of measuring data has never been this easy. The MarSurf M 410 is convenient and flexible to use – just like a modern smartphone. It has a practical touch display, an integrated PDF memory, innovative accessories, and can transfer data via Bluetooth – all of which effectively simplify your workload.

Benefit from functions that only Mahr can offer you. In addition to the practical and efficient design and the flexibility this offers, the MarSurf M 410 also has an automatic filter setting by detecting the surface structure. This automatic contacting also guarantees the unmatched reliability of your measurements. The magnetic 3-point holder for the probe arm and the freely combinable accessories offer additional process security.

Possible to separate the display and probe system

Optionally, you can use the measuring instrument as a mini mobile measuring station, for example by simply attaching the display to the wall using the supplied pivoted docking station.



Advantages

- Increased efficiency thanks to large integrated memory: More than 500,000 measuring programs and 1,500 PDF reports, can be expanded by 32 GB (microSD)
- Skidless probes ensure that the roughness and waviness can be measured without an additional measuring station being required – determination of R-, W-, and P-parameters
- Safe measuring results thanks to automated cutoff option
- Automatic zeroing ensures process and material safety
- IATF ready – simply activate/deactivate in the menu by automatically transferring the item and serial number of the measuring instrument
- Free MarCom software to transfer data

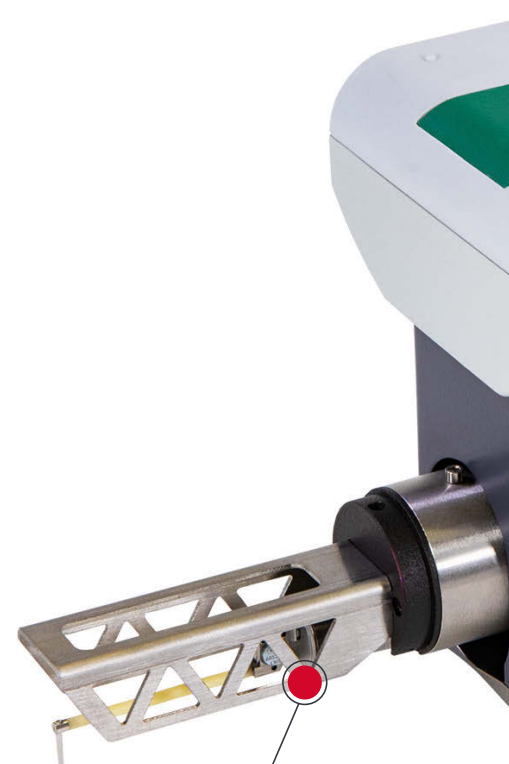

Magnetic probe holder

Probe arms can be changed quickly without tools and with additional protection: The magnetic 3-point holder ensures that the probe will not be broken in the event of a collision; it will simply be released by the magnetic holder.

Simple alignment of the probe system

The inclination is easy to correct via the menu-driven, graphic instructions.

Intuitive operation via touch display

Easy to operate just like a smartphone so that no training or introduction to the operating functions is required – you can just get started.

Creation of PDFs directly on the device

Practical: The device creates a complete PDF file without the need for additional software or transfer to a computer. Information can be added to the PDF files directly on the device.

Wireless data transmission

Connect your measuring instrument to a PC via Bluetooth and transfer your data wirelessly to Excel or another software application, for example.

Importing information using a scanner

Simply start your measuring program by scanning a QR or barcode. You do not need to enter any profile information as your saved measuring programs are linked with a corresponding code.



Flexible all-rounder **with various accessories**



Print directly, document easily.

Measuring results in paper form? Despite sounding a little outdated, even in the digital age it is sometimes the fastest way to simply transfer data or documents. In this case, a mobile Bluetooth printer is the perfect addition to your MarSurf M 410. It will enable you to save your work results directly on thermal paper.



Scan measuring programs quickly and reliably

Save measuring programs and link them directly to a QR or barcode. Or scan additional profile information into your program. The barcodes or QR codes can be easily mapped onto a drawing or workpiece for this purpose. Saves time and avoids errors during measurement – a real benefit for your quality assurance.

Scope of delivery

Remain flexible, especially when taking measurements. In addition to various practical accessories, the MarSurf M 410 already comes with a comprehensive scope of delivery that is tailored to your requirements.

- Docking station
- Probe protection
- Thermal paper
- Sturdy hard case
- Mains adapter with three adapters

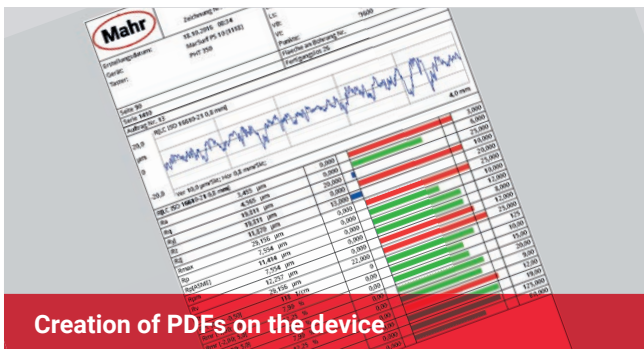

Creation of PDFs on the device

Avoid additional work steps. The practical PDF function enables the device to create a complete PDF file directly without the need for additional software or transfer to a computer. Information can be added to the PDF files directly on the device. This will not only save you time but will also eliminate any potential error sources (e.g., due to incorrect assignment).



External control via mini USB port

In production lines the M 410 can, for example, be controlled remotely by ASCII commands via the mini USB port. This ensures that the quality can be checked on a continuous basis by the external software, which in addition to increasing the flexibility also guarantees an increased level of process safety.



Hard case including thermal paper

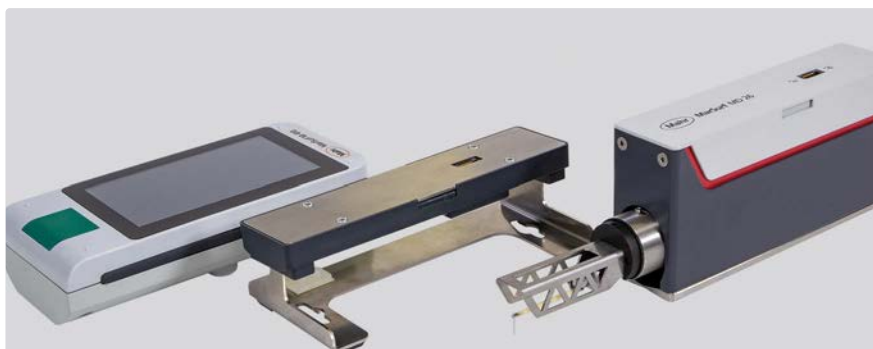

Docking station

MarSurf M 410

Mobile surface measuring instrument

FEATURES

Simple, innovative, flexible – modern surface metrology for handheld use

- Handy roughness tester for mobile use
- Simple and intuitive operation: As easy as operating a smartphone
- Large, backlit 4.3" TFT touch display
- Rotatable display
- Magnetic probe holder: Fast probe arm change without tools
- Thanks to skidless probe: measurements of roughness as well as waviness – no extra measuring station required, determination of R, W and P parameters
- Simple alignment of the probe system: The inclination can be easily corrected using the menu-guided graphic instructions.
- Process and material safety thanks to automatic zeroing
- Micro USB interface for remote control via ASCII commands, e.g. via software for statistical process control
- USB-A interface for connecting e.g. a USB Bluetooth adapter or the USB Bluetooth printer
- Wireless transmission of measurement results via Bluetooth stick to the free MarCom software
- Remote start of measurement via cable or Bluetooth
- Connection of a scanner for automatic start of the measuring programs or reading of protocol texts via barcode or QR code
- Specification of the profile section level C in μm or in % of Rz for the characteristic values Rmr and tp/li>
- Data backup as TXT, X3P, CSV and PDF file
- Transmission of measurement protocols and data optionally via Bluetooth or cable – IATF 16949 compliant secure traceability with MarConnect.
- Print directly to the mobile printer (as an option or directly in the set with printer)
- Creation of finished PDF protocols directly in the measuring device
- Customer-specific comments for the PDF log are entered directly on the MarSurf M 410
- MRK and ADK curve display and printing
- Measuring programs are saved (Quick & Easy)
- Mains-independent operation: over 1200 measurements without having to recharge the device
- Everything in the palm of your hand. Small size and low weight (approx. 500 g)
- Flexible device: Removable drive unit
- More than 50 parameters: Offer a performance range like a laboratory instrument.

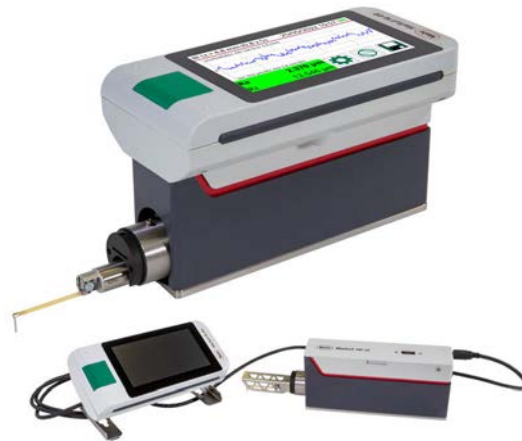

Application:

Mechanical engineering

Bearings, shafts, racks, valves, various components from the engineering and precision mechanics industries

Automotive

Steering, brake systems, transmissions, crankshafts, camshafts, cylinder heads, cylinder blocks, turbochargers

Medical

Roughness measurement on hip and knee endoprostheses

Aerospace

Turbine components

Optics

Diverse optical components

TECHNICAL DATA

| Order no. | 6910290 | 6910291 |
|--|--|--|
| IP protection category: | | IP 40 |
| Type | | M 410 |
| Parameters | Ra, Rq, Rz, Rz (JIS), Rz (Ry (JIS) entspr. Rz), Rmax, Rp, Rp (ASME), Rpm (ASME), Rv, R3z, Rk, Rpk, Rvk, Mr1, Mr2, A1, A2, Vo, Rt, RPC, Rmr (tp (JIS, ASME) entspr. Rmr), RSm, RS, Rdq, RSk, Rku, Rdc, RHtp, Pdc, Pa, Pt, PMr, Wa, Wq, WSm, WSk, Wt, CR, CF, CL, R, Ar, Rx, W, AW (MOTIF), Wx (MOTIF), Wte (MOTIF), NW (MOTIF), NR (MOTIF), NCRX (MOTIF), CPM (MOTIF) | |
| Stylus | 2 μm ; 5 μm | |
| Storage capacity | min. 3900 profiles, min. 500,000 results, min. 1500 PDF logs, expandable with microSD card up to 32 GB (increases storage capacity by a factor of 320) | |
| Languages | German, English, French, Italian, Spanish, Portugese, Dutch, Swedish, Russian, Polish, Czech, Japanese, Chinese, Korean, Hungarian, Turkish, Romanian | |
| Other | Lock/code word protection, date/time | |
| Data interface: | USB A, MarConnect (RS-232), Micro SD slot for SD / SDHC cards up to 32 GB | |
| Relative humidity | 30 % to 85 %, non-condensing! | |
| System of protection | IP 40 | |
| Rechargeable batteries | Li-Ion battery, 3.7 V, nominal capacity 11.6 Wh, min. 500 measurements | |
| Wide range power supply | 100 to 264 V | |
| H x W x D | mm | 198 mm x 77 mm x 97 mm |
| (L x W x H) for drive unit | mm | 194 mm x 38 mm x 72 mm |
| (L x W x H) for measuring instrument | mm | 162 mm x 77 mm x 35 mm |
| Measuring principle | tactile stylus method | |
| Probe | inductive skidless probe system | |
| Measuring range | mm | 500 μm ($\pm 250 \mu\text{m}$) for probe arm length 45 mm to 1500 μm ($\pm 750 \mu\text{m}$) for probe arm length 135 mm |
| Filter according to ISO/JIS | Gaussian filter according to DIN EN ISO 16610-21, robust Gaussian filter according to DIN EN ISO 16610-31, special filter according to DIN EN ISO 13565-1, Is filter according to DIN EN ISO 3274 (can be switched off) | |
| Cutoff lc according to ISO/JIS | 0.08 mm, 0.25 mm, 0.8 mm, 2.5 mm, automatic filter detection, variable | |
| Number n of sampling length according to ISO/JIS | selectable: 1 to 16 | |
| Short stroke under ISO/JIS | selectable | |
| Measuring force | N | 0.00075 |
| Measuring speed | 0.1 mm/s; 0.5 mm/s; 1.0 mm/s | |
| Positioning speed | 3 mm/s | |
| Weight drive unit | 1120 g | |
| Weight measuring instrument | 300 g | |

- Quick access to your desired functions through favorites storage in the display
- Automatic cutoff selection: ensures correct measurement results even for the non-measuring technician
- Free software "MarWin EasyRoughness Viewer" for further documentation (statistics, multiple profiles and results on one page

etc.) available for download on the Mahr website.

Package contents:

- MarSurf M 410 operating unit
- Drive unit MD 26
- 1 standard probe arm BFW A 10-45-2/90°, standardized
- Docking station for operating unit
- Probe protection

- Built-in rechargeable battery
- Charger / 3 mains adapters
- Height adjustment (integrated)
- USB cable
- Extension cable for drive unit (length 1.2 m)
- Operating instructions

MarSurf M 410

Mobile surface measuring instrument

ACCESSORIES

| Order no. | Description | Type |
|------------|---|-----------------------|
| 6910271 | Printer set for MarSurf M 310, MarSurf M 410 and Digmar 817 CLT | DP-B1 |
| 4102603 | Data cable USB bidirectional (2 m) | DK-U1 |
| 3028620 | USB 2D scanner Honeywell Xenon 1900 | Handset scanner cable |
| 3003856 | USB Bluetooth adapter | USB BT |
| 3028820 | 2D scanner Bluetooth Zebra DS2278 | Handset scanner BT |
| 6852403 | Probe arm | BFW |
| 6910294 | Measuring stand mount MD 26 | |
| 6710803 | Measuring stand 300 mm with cast iron base | ST-D |
| 6710806 | Measuring stand 300 mm with granite plate | ST-F |
| 6710807 | Measuring stand 300 mm with granite plate and T-slot | ST-G |
| 2247086 | Adjustable mounting bracket to connect to 814 SR | 814 Sh |
| 4426100 | Height measuring and scribing instrument, 0 –350 mm | 814 SR |
| 4426101 | Height measuring and scribing instrument, 0 –600 mm | 814 SR |
| 6710401 | V-block | PP |
| 6710604 | Parallel vice | PPS |
| 6710529 | XY table | CT 120 |
| 4246819 | Set of miniature precision vises Set contents: Mini-vises, jaw widths 15 / 25 / 35 mm, with tripod and V-blocks and miniature dividing attachments | 109 PS |
| 6820420 | Roughness standard with Mahr calibration certificate, profile depth 10 µm | PRN 10 |
| 4413000 | Measuring tripod with triangular pedestal 300 mm | 815 GN |
| 4413001 | Measuring tripod with triangular pedestal 500 mm | 815 GN |
| 4413005 | Measuring tripod with triangular pedestal 750 mm | 815 GN |
| 4416000 | Measuring tripod with magnetic base | 815 MA |
| 6299436 | software MarWin EasyRoughness mobile | M 310 PC |
| 6299443 | Software | Software |
| 6910240 | Protective films for LCD, real glass (3 pieces) | SF LCD |
| 6850500 | Magnetic fixture PS 10 / M 310 | MH |
| 680000DKS | Geometric standard, sinusoidal profile | MGS 1 |
| 680000KAL | Geometric standard, sinusoidal profile | MGS 1 |
| 680001DKS | Geometric standard, sinusoidal profile | MGS 3 |
| 680001KAL | Geometric standard, sinusoidal profile | MGS 3 |
| 680002DKS | Geometric standard, sinusoidal profile | MGS 10 |
| 680002KAL | Geometric standard, sinusoidal profile | MGS 10 |
| 6820901DKS | Roughness standard | MRS 1,5 |
| 6820901KAL | Roughness standard | MRS 1,5 |
| 6820903DKS | Roughness standard | MRS 3 |
| 6820903KAL | Roughness standard | MRS 3 |



ST-D

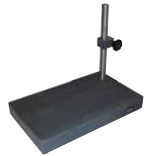

ST-F

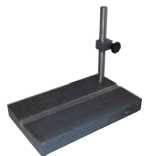

ST-G



814 Sh



814 SR



109 PS

Clever combination: High performer for surface measurements

Combine the new MarSurf M 410 with the tried and tested MarWin EasyRoughness software and use it as a drive unit for your surface measurements. This extends the measuring spectrum by many parameters enabling you to complete even more comprehensive evaluations.

This combines the handiness of the MarSurf M 410 with the wider range of software functions.

The measuring instrument can be easily connected to the computer by cable or Bluetooth wireless technology. The MarWin EasyRoughness software is your first choice for all MarSurf applications thanks to its versatile customization and design options, and comprehensive functions thus providing you with functions to cut profiles, export data, complete multiple measurements, and much more.



Advantages

- Numerous functions already included in the software, such as cutting profiles, exporting data, and completing multiple measurements
- Software can be expanded to include a variety of options, such as "OS-STAT", "Digital I/O", or "Profile processing"
- User administration for logging on and administering users with different rights
- Automatic export of profile files, results files, and records in PDF format
- Interactive zoom to specify a profile section to be evaluated and recalculate selected parameters



Highlights at a glance

Multiple measurement

Measurement of twin contours and multiple measurements with segmentations. Depending on the drive unit selected and the measuring stand, it is possible to perform an automatic zenith search, implement absolute and relative positioning, and program automatic processes. The software provides a measuring station view with operating messages and sometimes photos between measurements.

Profile processing

This function makes it possible to process profiles, such as cutting out valleys or peaks, simulating spheres, mirroring profiles, rotating profiles, adding ranges, or merging two or more profiles into a new one. In addition, edge filters hide topics that should not be evaluated.

Virtual rulers

Interactive setting of distances in X and Z direction in the profile field make it possible to view defined profile sections.

Start program sequences using function keys

Simply click to activate results, profiles, globally standardized parameters, and characteristic curves. They can then simply be output in the record. The entries can be selected directly from the "Surface parameters", "Evaluation", "Measuring record", and "Record preview" tabs, making the system quick and easy to use.

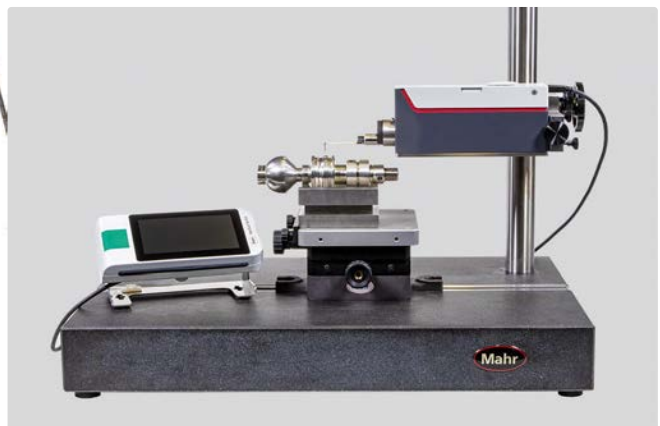

MarSurf M 410 / MD 26 with Software Easy Roughness

Mobile surface measuring instrument

FEATURES

- Handy roughness tester for mobile use
- Magnetic probe holder: Fast probe arm change without tools
- Thanks to skidless probe: measurements of roughness as well as waviness – no extra measuring station required, determination of R, W and P parameters
- Connection of a scanner for automatic start of the measuring programs or reading of protocol texts via barcode or QR code
- More than 80 parameters for R, P, W profiles according to current standard ISO/JIS or MOTIF (ISO 12085)
- Bandpass filter Ls according to current standard, Ls can also be switched off or freely varied
- Extensive logging
- Quick & Easy measuring programs can be created quickly in the learning procedure
- Automatic function for standard-compliant selection of cutoff and scanning distance
- Support of different calibration methods (static and dynamic) with presetting of the parameter Ra or Rz
- Adjustable maintenance and calibration intervals
- Many measuring station configurations are possible for individual applications
- Flexibility of the system through various options
- Different user levels protect against incorrect operation of the device and ensure that no unauthorized users can use the device

Package contents:

- MarSurf M 410 operating unit
- Drive unit MD 26
- 1 standard probe arm BFW A 10–45–2/90°, standardized
- Docking station for operating unit
- Probe protection
- Built-in rechargeable battery
- Charger / 3 mains adapters
- Height adjustment (integrated)
- USB cable
- Extension cable for drive unit (length 1.2 m)
- Software MarWin EasyRoughness mobile
- Operating instructions



TECHNICAL DATA

| Order no. | 6910290 + 6299436 | 6910292 + 6299436 |
|--|---------------------------------|---|
| Type | M 410 + Software Easy Roughness | MD 26 + Software Easy Roughness |
| Stylus | | 2 µm; 5 µm |
| Rechargeable batteries | | Li-Ion battery, 3.7 V, nominal capacity 11.6 Wh, min. 1200 measurements |
| (L x W x H) for drive unit | | 194 mm x 38 mm x 72 mm |
| Measuring principle | | skidless probe system |
| Probe | | inductive skidless probe system |
| Measuring range | mm | 500 µm (±250 µm) for probe arm length 45 mm to 1500 µm (±750 µm) for probe arm 135 mm |
| Filter according to ISO/JIS | | Gaussian filter according to DIN EN ISO 16610–21, robust Gaussian filter according to DIN EN ISO 16610–31, special filter according to DIN EN ISO 13565–1, Ls filter according to DIN EN ISO 3274 (can be switched off) |
| Cutoff lc according to ISO/JIS | | 0.08 mm, 0.25 mm, 0.8 mm, 2.5 mm, automatic filter detection, variable |
| Number n of sampling length according to ISO/JIS | | selectable: 1 to 16 |
| Short stroke under ISO/JIS | | selectable |
| Traversing length Lt according ISO/JIS | | variable |
| Measuring force | N | 0.0007 |
| Measuring speed | | 0.1 mm/s; 0.5 mm/s; 1.0 mm/s |
| Positioning speed | | 3 mm/s |
| Weight drive unit | | 1120 g |

Application:

Mechanical engineering

Bearings, shafts, racks, valves, various components from the engineering and precision mechanics industries

Automotive

Steering, brake systems, transmissions, crankshafts, camshafts, cylinder heads, cylinder blocks, turbochargers

Medical

Roughness measurement on hip and knee endoprostheses

Aerospace

Turbine components

Optics

Diverse optical components

MarSurf M 410 / MD 26 with Software Easy Roughness

Mobile surface measuring instrument

ACCESSORIES

| Order no. | Description | Type |
|------------|---|--------------------------|
| 6910271 | Printer set for MarSurf M 310, MarSurf M 410 and Digmar 817 CLT | DP-B1 |
| 4102603 | Data cable USB bidirectional (2 m) | DK-U1 |
| 3028620 | USB 2D scanner Honeywell Xenon 1900 | Handset scanner cable |
| 3003856 | USB Bluetooth adapter | USB BT |
| 3028820 | 2D scanner Bluetooth Zebra DS2278 | Handset scanner BT |
| 6852403 | Probe arm | BFW |
| 6910294 | Measuring stand mount MD 26 | |
| 6710803 | Measuring stand 300 mm with cast iron base | ST-D |
| 6710806 | Measuring stand 300 mm with granite plate | ST-F |
| 6710807 | Measuring stand 300 mm with granite plate and T-slot | ST-G |
| 2247086 | Adjustable mounting bracket to connect to 814 SR | 814 Sh |
| 4426100 | Height measuring and scribing instrument, 0 –350 mm | 814 SR |
| 4426101 | Height measuring and scribing instrument, 0 –600 mm | 814 SR |
| 6710401 | V-block | PP |
| 6710604 | Parallel vice | PPS |
| 6710529 | XY table | CT 120 |
| 4246819 | Set of miniature precision vises Set contents: Mini-vises, jaw widths 15 / 25 / 35 mm, with tripod and V-blocks and miniature dividing attachments | 109 PS |
| 6820420 | Roughness standard with Mahr calibration certificate, profile depth 10 µm | PRN 10 |
| 4413000 | Measuring tripod with triangular pedestal 300 mm | 815 GN |
| 4413001 | Measuring tripod with triangular pedestal 500 mm | 815 GN |
| 4413005 | Measuring tripod with triangular pedestal 750 mm | 815 GN |
| 4416000 | Measuring tripod with magnetic base | 815 MA |
| 6299443 | Software | Software |
| 6910240 | Protective films for LCD, real glass (3 pieces) | SF LCD |
| 6850500 | Magnetic fixture PS 10 / M 310 | MH |
| 6800000DKS | Geometric standard, sinusoidal profile | MGS 1 |
| 6800000KAL | Geometric standard, sinusoidal profile | MGS 1 |
| 6800001DKS | Geometric standard, sinusoidal profile | MGS 3 |
| 6800001KAL | Geometric standard, sinusoidal profile | MGS 3 |
| 6800002DKS | Geometric standard, sinusoidal profile | MGS 10 |
| 6800002KAL | Geometric standard, sinusoidal profile | MGS 10 |
| 6820901DKS | Roughness standard | MRS 1,5 |
| 6820901KAL | Roughness standard | MRS 1,5 |
| 6820903DKS | Roughness standard | MRS 3 |
| 6820903KAL | Roughness standard | MRS 3 |
| 6910205 | Software | SW PS1/ M300 Explorer |



ST-D

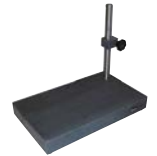

ST-F



ST-G



814 Sh



814 SR



109 PS

Automated measurements with robot loading

You requested and we have responded: Our department Mahr Engineered Solutions (MES) has developed a cost-effective solution to automate recurring measurements. A collaborative robot loads measuring stations into the measuring room or close to the production area without the need for an operator, thus significantly increasing the efficiency of your measuring station and drastically reducing the overall costs.

The new solution was first implemented on a MarSurf contour and roughness measuring station. It is particularly useful for you if you wish to check a high number of recurring workpieces on a continuous and prompt basis. The system has a workpiece store that comprises removable magazines which contain the parts to be measured. The MarSurf measuring station is positioned on the workpiece store, while a robotic arm is attached to the side so that it can easily access the magazines. The robotic arm then positions the removed component on the workpiece holder of the MarSurf device and the measurement starts automatically. Once the measurement has been completed successfully, the robot returns the part back to the workpiece store.

We are currently designing the robot for MarSurf configurations. However, in future it is also conceivable that it could be implemented for other measuring stations, such as form measurements using our MarForm MMQ range. By the way, the solution is not just suitable for new Mahr systems, you can also upgrade existing devices with it.



Advantages

- Cost-effective and standardized solution for pallet measurements
- Same amount of space required as a standard measuring station
- No personnel requirements, except to load the magazines
- Increased service life of the measuring instrument even with three-shift operation
- Simultaneous loading and measuring possible depending on the application
- Robot can simply be reprogrammed for other workpieces, ensuring it can be used flexibly

Automatic sequence

The robotic arm automatically positions a component for the measurement.





Automatic workpiece removal

The robot removes a component from the workpiece magazine using a gripper that was produced using a 3D printer to fit accurately.

Flexible applications

The robot is easy to reprogramme and can thus process a variety of workpieces.

Universal solution

Suitable for new or well-established MarSurf or MarForm: The Mahr Feeder is suitable for lots of measuring stations.

Time savings

Simultaneous measuring and loading is possible depending on the application.

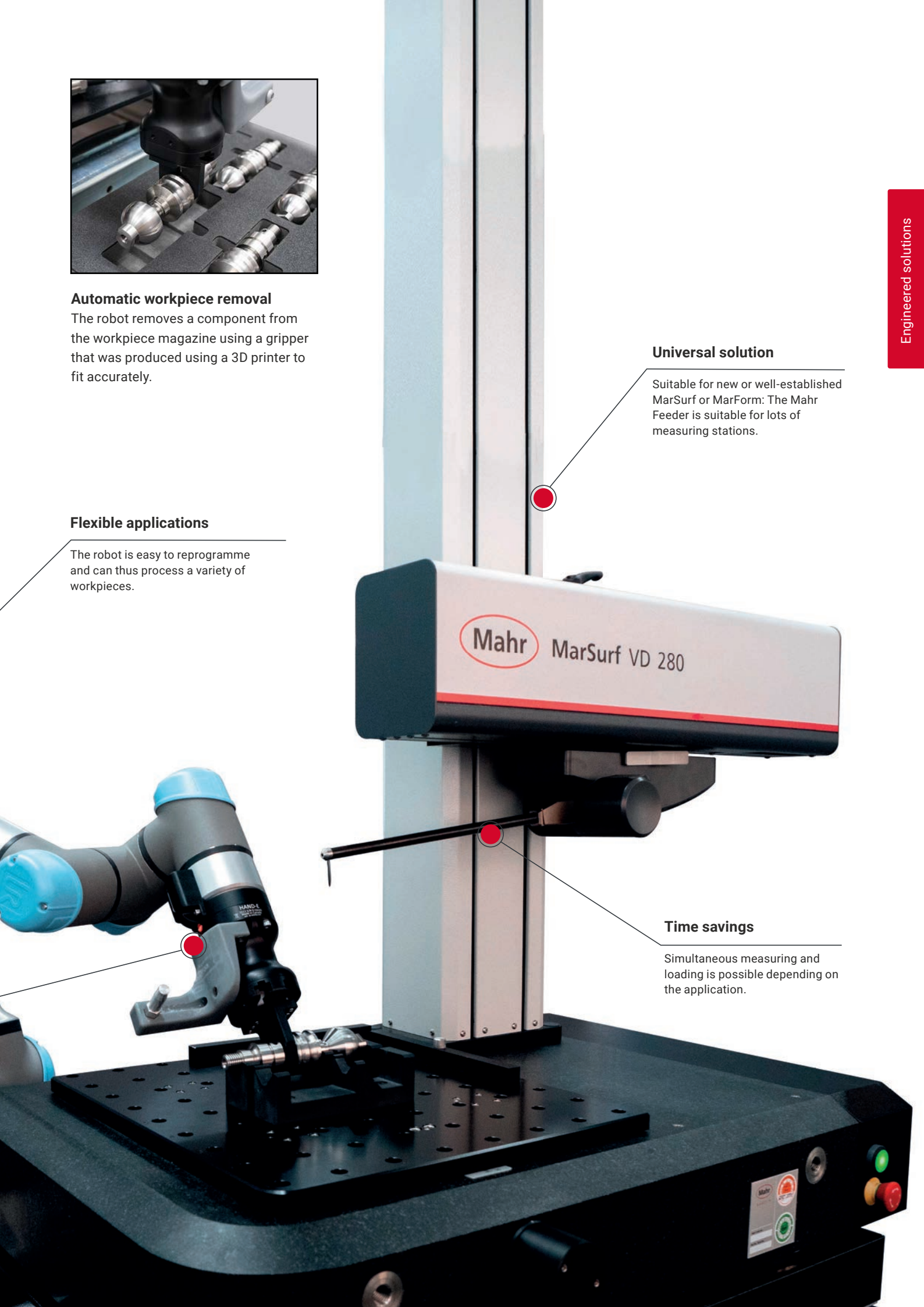

Fast and precise **measure- ment during production**

The cylinder coordinate measuring machines from the Mar4D PLQ product range measure rotationally symmetrical workpieces with more flexibility and more conveniently than ever before. They also operate at the highest speed and level of precision providing fast and reliable measuring results.

The Mar4D PLQ 4200-T2 and Mar4D PLQ 4200-T4 variants offer high-performance measurement solutions for complex rotationally symmetrical workpieces. The multisensor technology covers a particularly broad range of dimensional measuring tasks. The machines also have a particularly sturdy design enabling measurements to be completed directly during production, providing you with shorter processing times and thus increasing your throughput and productivity rates extraordinarily. They are also equipped with a motorized tailstock enabling them to also adjust workpieces between the centering tips. The equipment provided as standard includes a C-axis measuring machine. This machine guarantees highly accurate roundness and radial runout measurements with deviations of <40 nm.



Advantages

- Future-proof thanks to combined measuring technology: optical and tactile solution in one machine
- Versatile: Inspection of several features including the length, diameter, form, position, contour, roundness, roughness, or 3D geometries, such as the symmetry, during a single measuring run.
- Fast and precise: Unique speed and optimum axis accuracy even as the tolerances become smaller achieved thanks to specially developed control architecture
- Ergonomic operation and unique safety concept





Mar4D | PLQ 4200-T4

Unique centering and tilting table: A guarantee of precision and speed

The outstanding equipment feature of the Mar4D PLQ 4200-T4 model is the fully automated centering and tilting table that we have newly developed. It aligns workpieces, that are not manufactured and measured between two tips, in the shortest amount of time and with an accuracy of micrometers, for example from 4 mm to 1 μ m in just 30 seconds. This completely arithmetic method of correcting alignment errors is thus far superior.

Comparison of Mar4D PLQ models

| Model | Axes | Sensor technology | Motorized tailstock | Centering and tilting table | Workpiece size |
|-------------------|--------------|-------------------|---------------------|-----------------------------|---|
| Mar4D PLQ 4200-T2 | C, X1, X2, Z | optical, tactile | x | | Ø 200 mm length 730/1,000 mm 20/50 kg |
| Mar4D PLQ 4200-T4 | C, X1, X2, Z | optical, tactile | x | x | Ø 200 mm length 450 mm 20/50 kg |

Process reliability when measuring

Monitoring systems in the machine record and compensate for external influences in real time, such as temperature and vibration.

More secure

The motorized tailstock with clamping force monitor secures the workpieces mounted in the centering tips perfectly in alignment without operator intervention.

Versatile

The multisensor technology of the Mar4D PLQ 4200-T2/T4 enables the measurement of various rotationally symmetrical workpieces directly during production.

Reliable software

Thanks to its clearly structured user interface, the MarWin platform software is very user friendly: learn once, apply again and again.

Ergonomic design

The sophisticated mechanical engineering guarantees easy and safe operation.



<https://metrology.mahr.com/en/mar4d-plq>

A variety of products for numerous industries

For more than 160 years the name "Mahr" has stood for modern technology, maximum precision and pioneering inventions. Today, the Mahr Group is a global operation, supporting customers in a wide range of industrial segments. A long-term focus is key to reliable, high-quality products, and sustainable customer relations. Close cooperation with our customers leads to a comprehensive understanding of the special requirements and technical challenges associated with these industries.

7
Industries



Automotive



Aviation



Electronics



Machines &
Tools



Medical

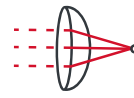

Optics

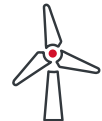

New Energies

More than

20

Product groups

Whatever the measuring task you are facing, the right measuring technology will help you tackle the most complex applications. Take advantage of Mahr's full range of measuring technology: We have everything you need in over 20 different product groups, from manual calipers to customized fully-automated, robot-controlled measuring stations.

For

160 years

premium quality by Mahr



Mahr GmbH
Carl-Mahr-Straße 1
37073 Göttingen
Germany

Tel.: +49 551 7073 800
info@mahr.com
www.mahr.com

© **Mahr** GmbH

We reserve the right to make changes to our products,
especially due to technical improvements and further developments.
All illustrations, numerical values, etc. are therefore subject to change.

3766205 | 09.2023