



**WILLRICH PRECISION
I N S T R U M E N T**

THINK MEASUREMENT... THINK WILLRICH

Ph 866-945-5742 email:sales@willrich.com

DEFINING THE AI ERA OF QUALITY DISCOVERY

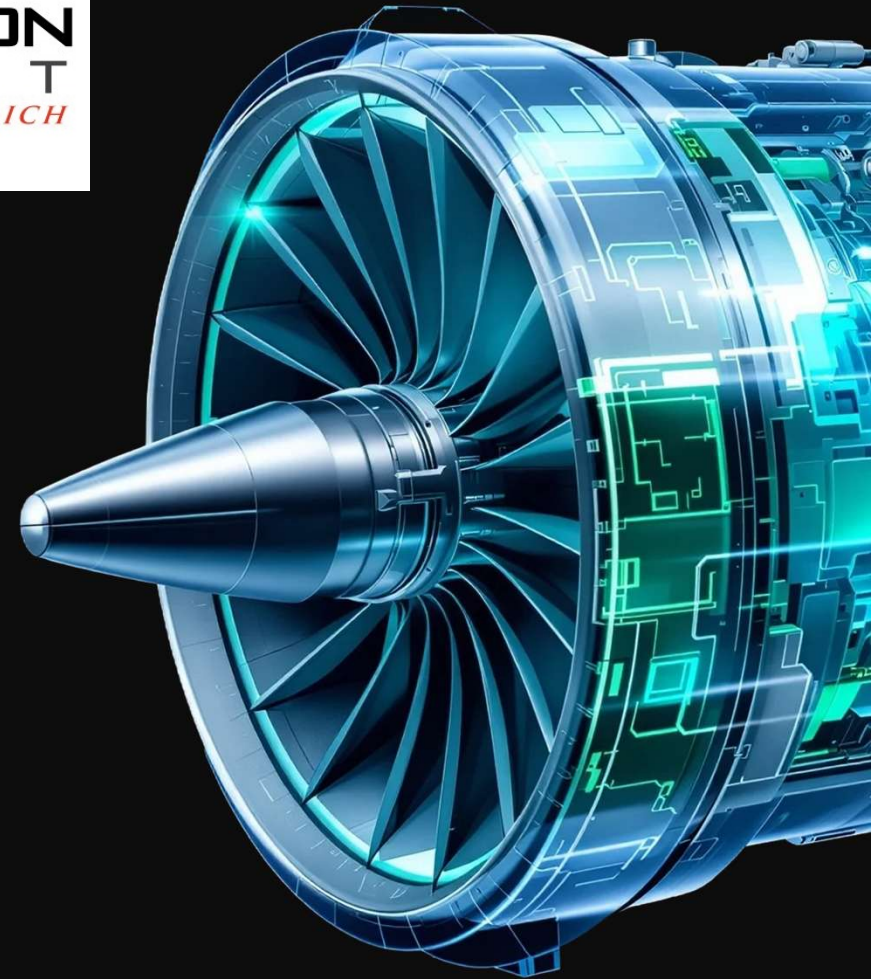

Mastering AI-Powered Visual Inspection for Industrial Manufacturing

AEROSPACE



AUTOMOTIVE



ELECTRONICS

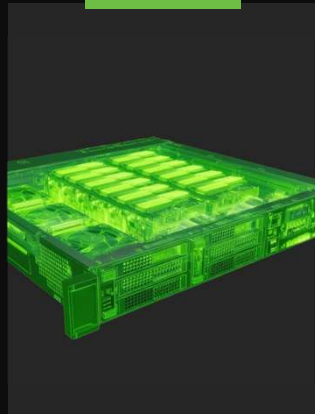

MEDICAL

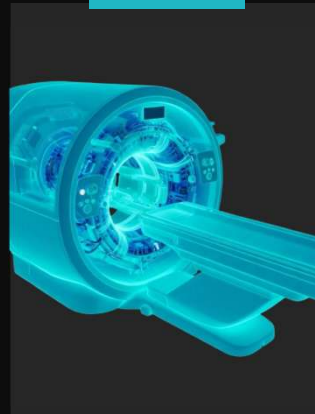

DEFENSE



MORE



Founded in 2015
Relaunch in
2025



HQ in Israel & USA



Global footprint and
distribution network

Empowering the World's Industry Leaders

LOCKHEED MARTIN



flex



RAFAEL



DENSO
Member of the TOYOTA Group

JABIL



YAMAHA

Mitutoyo



solar edge



preh

amazon Leo



Continental



100+
INSTALLATIONS

Introducing KITOV Quality Loop

3-Domain Workflow

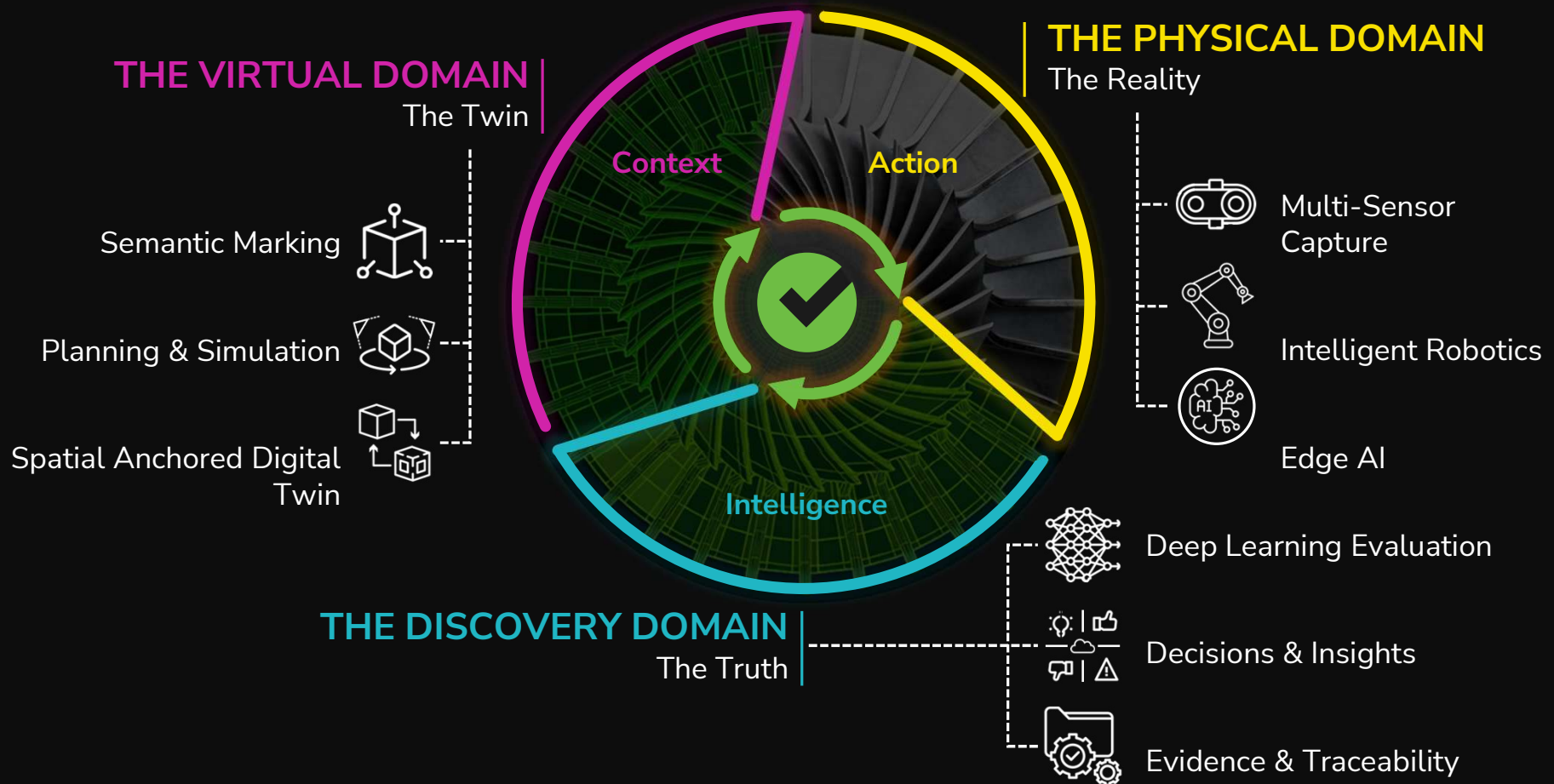

Designing Today's Most Intelligent Solution

AUTOMATED PLANNING

- Automated robotic systems
- Intuitive model-based marking
- Universal CAD & QIF support
- Optimized test-specific practices

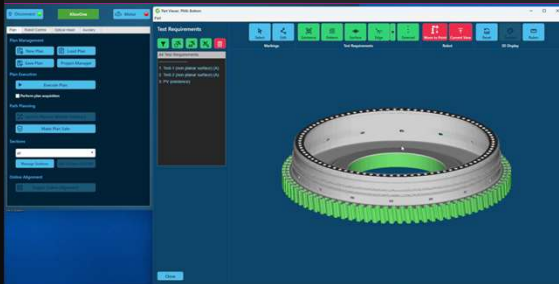

 AI-Powered

SMART VISUAL INSPECTION

- Hybrid AI & computer vision
- Planner-enhanced inspection
- Real-time camera calibration
- Continuous improvement cycles

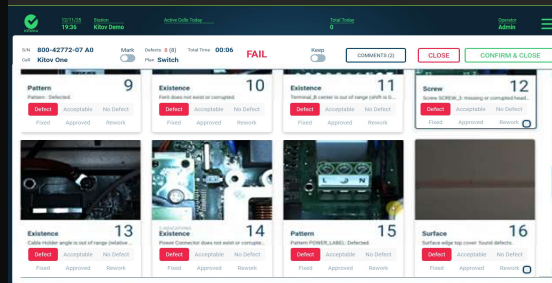

 AI-Powered

ACTIONABLE QUALITY DISCOVERY

- Automated defect classification
- Dynamic yield performance tracking
- Digital evidence & total traceability
- Actionable insights & analytics



 AI-Powered

Open Software Platform – Any Robot, Any Sensor, Any Automation Environment

Tackling The Quality Pain

Complex Geometries





High-Mix Production



Large Defect Variability

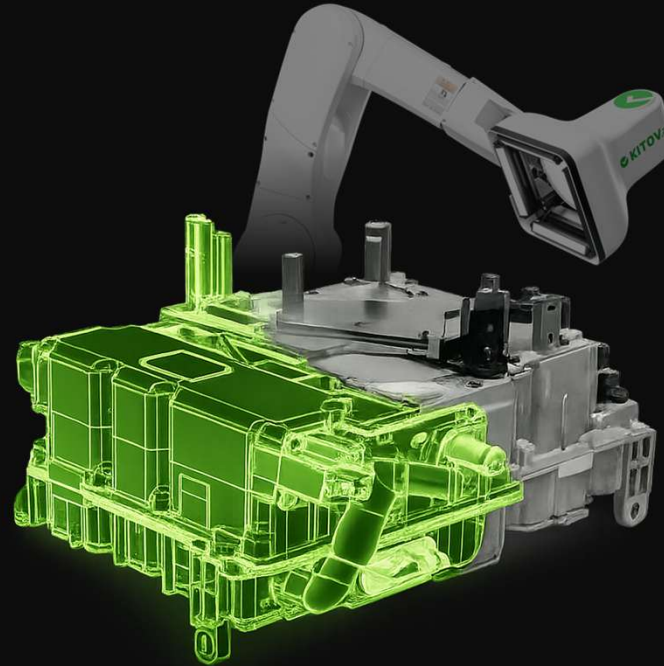

Zero-Tolerance Standards



Accelerate Product Introduction



Scale Operations



Reduce Costs



Unparalleled Quality



Reduce COPG
Cost-Of-Poor-Quality



Delivering Superior Technology

VISION



High-Fidelity
Multi-Sensor Acquisition



Adaptive Imaging
(Illumination &
Calibration)

ROBOTICS



Intelligent
Path-Planning



6/7-Axis
Motion Control

AI



Semantic
AI Detectors



Anomaly Detection
& Classification

METROLOGY



CAD-Defined
Metrology



In-Line
3D Measurement

MODEL



Model Based
Definition (MBD)

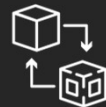

Validated
Digital Twin

High-End Visual Inspection and Quality Discovery

Building High-Impact Market Solutions

System-Level Inspection (Assembly Lines)

KITOV K-series



K-Core
6/7 -Axis Robotic System



K-Eye Solo *
Fixed Camera System

Object-Level Inspection (Discrete Parts)

KITOV X-series



X-Core
6/7 -Axis Robotic System



X-Prime *
CAD-Integrated
7-Axis Robotic System

Offering Flexible Implementation Models

KITOV Integrated Solution

Ready to Use Systems



Multiple Robot Options

Bring Your Own Robot & Automation

Partnership & Licensing



KITOV Sphere



Manufacturer / Integrator

Providing Comprehensive Production Solutions

Unit Assembly

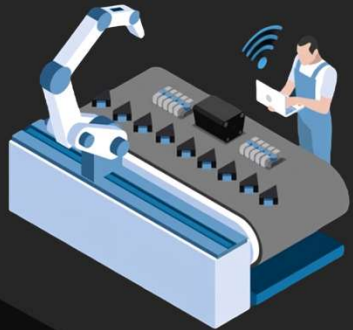

Unit Inspection

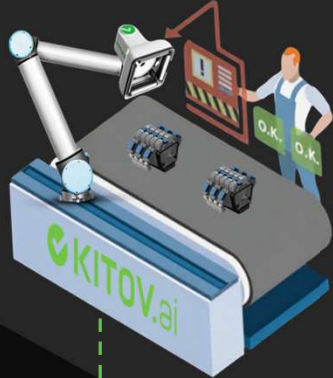

Final Assembly



Part Assembly

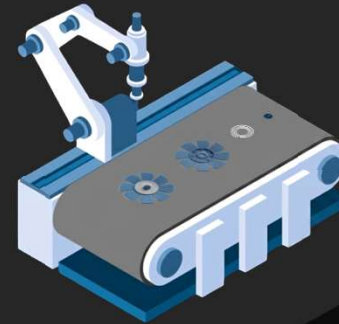

Part Inspection



Final Inspection



Discovering Everything



SURFACE & FINISH

- Edge & surface dents
- Scratches & abrasions
- Oxidation & corrosion
- Coating peel & delamination
- Erosion, pitting, & flash

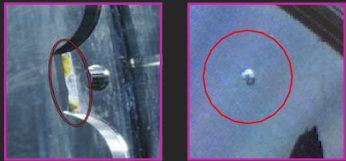

MECHANICAL & ASSEMBLY

- Loose or defective screws
- Missing or wrong parts
- Bent pins & incomplete insertion
- Misalignment & skew
- Foreign Object Debris

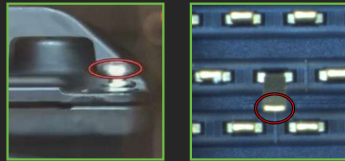

STRUCTURAL & MATERIAL

- Defective welding
- Excess material & weld splatter
- Deformation & warpage
- Porosity & voids
- Fatigue & stress cracking

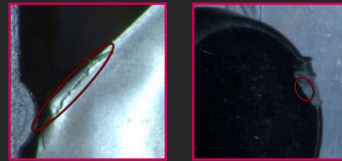

COMPONENTS & PARTS

- Wrong item
- Corrupted or defective item
- Polarity reversal
- Solder bridges & splashes
- Tombstoning & component lift

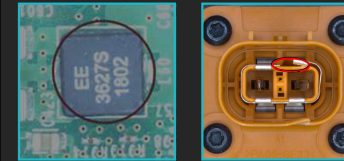

LABELING & PRINTING

- Defective labels
- Defective or corrupted print
- OCV/OCR failure
- Incorrect orientation
- Authentication & revision match



AND MORE...

Uncovering Vital Manufacturing Insights

Unified Data Collection

Aggregate inspection data from every unit across the production line



Cross-Process Data Aggregation

Track repeated inspections of specific units across times and locations

Yield Performance Tracking

Monitor yield and quality trends across lines, shifts, and facilities

AI-Driven Insight Discovery

Identify recurring, growing, and emerging defect patterns

Actionable Production Intelligence

Drive root-cause analysis, corrective actions, and process improvements

Digital Evidence & Traceability

Ensure full auditability and complete digital history for every unit

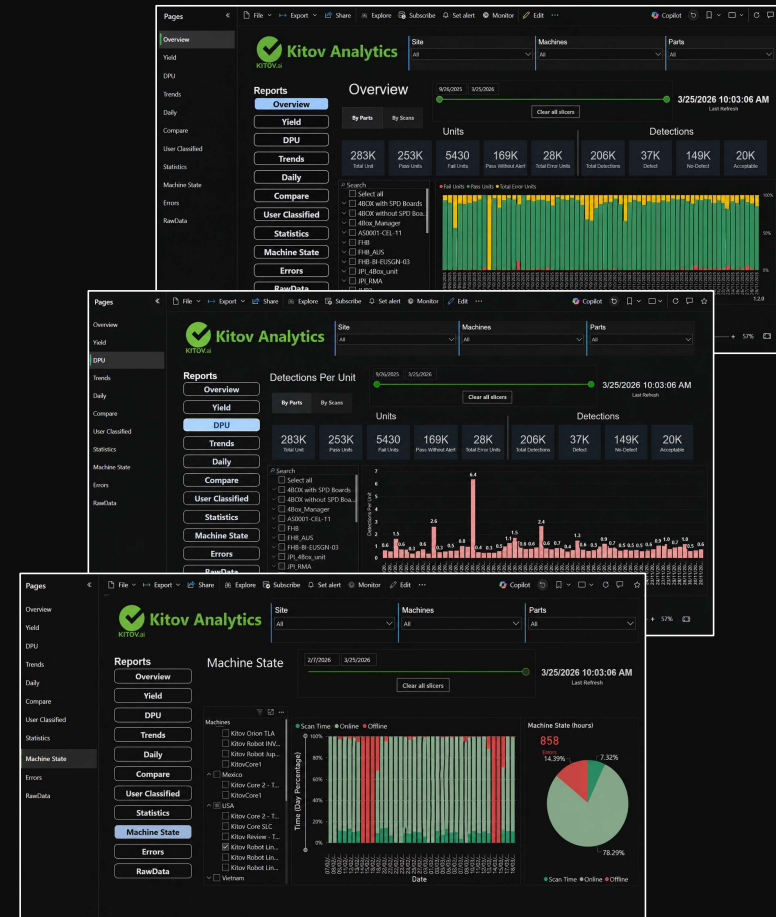

Addressing the MRO Challenge

Automated Bench Triage

Eliminate Subjectivity

Standardized AI ensures consistent, unbiased inspection results.

Scale Capacity

High-throughput robotics eliminate labor bottlenecks and fatigue.

Defect Classification

Automated categorization of surface damage streamlines part routing (Serviceable/FPI/Scrap).

Digital Traceability

Serial-level photographic logs provide a permanent audit trail

Complex Components Inspection

Integrated Structure Inspection

Comprehensive scan of the entire component in a single session (i.e. all airfoils and the disc).

Total Surface Visibility

Systematic robotic navigation reaches internal passages unreachable by humans.

In-Line Metrology

Integrated 3D profiling replaces slow, manual measurement stations.

Scrap Mitigation

Precise automated verdicts prevent costly, incorrect scrap decisions.

Creating Metrology-Enhanced Inspection

Multi-Sensor Inspection System

3D Measurement LMI Gocator 3210



Snapshot Scanning

60–90 μm XY resolution for high-detail stationary inspection.

Stereo Vision

Dual-camera design captures three views with 4.7 μm Z-repeatability.

Onboard Processing

Built-in controllers match rapid inline production speeds.

Factory Integration

35 μm VDI/VDE accuracy pre-calibrated for robotic setup.

Surface Gauge 4D InSpec



Defect Quantification

Measures pits and scratches from 4 μm to 2.5 mm deep.

Direct Measurement

Quantifies features on large parts without physical replication.

High Resolution

Micrometer-level precision for non-contact surface analysis.

Complex Geometries

Specialized optics measure intricate shapes and tight radii.

Surface Form Metrology Zygo Laser Interferometer

Topography & Texture

High-precision topography and roughness via laser interferometry.

High-Dynamic Acquisition

550 fps sensor for rapid, accurate capture in production.

Precision Z-Scanning

400 μm scan and 2 mm FOV for detailed characterization..

Advanced Repeatability

Sub-nanometer precision for high-fidelity surface verification.

Automated GD&T: Surface Texture, Volumetric Defect Analysis, & High-Precision Feature Measurement

Driving AI-based Digital Twinning

Digital Life-Cycle Traceability

Automated Audit Trail

Every defect is logged by serial number with both photographic and metrology-grade data.

Pre & Post Tracking

Side-by-side visual and dimensional evidence verifies repair quality and restoration.

Historical Data

Centralized defect history across multiple shop visits enables long-term trend analysis.

Compliance Assurance

Standardized digital records simplify regulatory audits and provide robust liability protection.

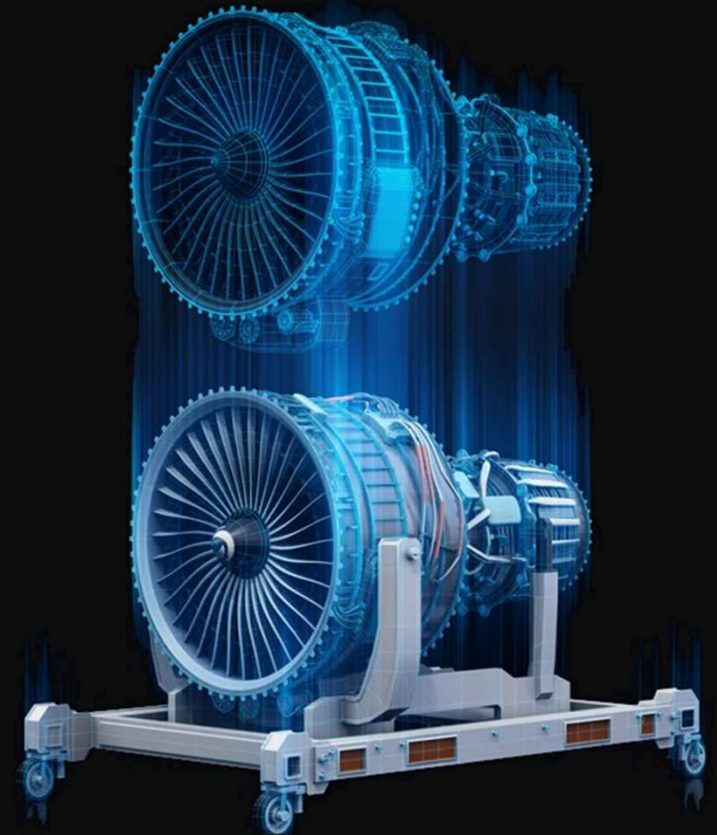

KITOV in Action: Surface Inspection

Automated surface inspection with
Kitov CORE+
and
4D InSpec surface gauge



Pioneering Next Frontiers of Quality Discovery

Fixed-Cell
Robotics



Autonomous
Mobile Robots



Surface Roughness **SENSOFAR**

3-in-1



Ai Focus Variation

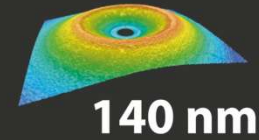

Shape measured in **2s**

Interferometry

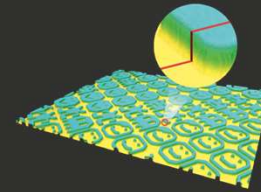

Confocal

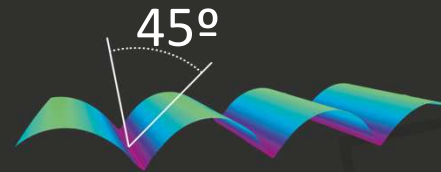

Innovating the Next in Quality Discovery

2026

- Improved AI engine
- New K-Node (Interface and Control Node)
- X-Prime CAD-Integrated 7-Axis Robotic System
- 3D camera
- Metrology sensor
- K-Eye Solo release Fixed Camera System

2027

- New UI/UX
- New optical head
- Polarized sensor
- Inverse configuration
- Metrology sensor
- CAD2Scan: Creo, QIF
- Process / Production quality analysis

2028

- Enhanced metrology
- CAD2Scan: CATIA, Siemens NX
- Offline simulator
- Preventive maintenance insights
- Any Depth-of-Field

Transforming Quality Discovery: Where KITOV.ai Excels



COMPLEX 3D GEOMETRIES

Automates full-coverage inspection for intricate parts with occlusions and tight lighting constraints



HIGH-MIX THROUGHPUT

Eliminates planning bottlenecks with rapid re-configuration for frequent ECOs and product changes



HIGH COST-OF-ESCAPE

Provides ultra-high inspection reliability for mission-critical industries



FULL DIGITAL TRACEABILITY

Links every unit to a comprehensive record of both high-resolution image evidence and precise metrology results



Customers and Applications



Case Study: NVIDIA

Customer

- Customer: Nvidia
- Sector: Electronics
- Global pioneer in full-stack accelerated computing and AI.
- Leading producer of enterprise-grade networking solutions.
- S&P and NASDAQ-traded with a zero-downtime requirement.

Application

- Inspection of 380 connectors per unit, totaling 15,000+ individual pins.
- Automated robotic path planning for visual access to intricate ports.
- Real-time detection of defects occurring during the production phase.
- Digital archiving of images to support and validate warranty claims.

Impact

- Achieved an 80% reduction in total test time.
- Realized zero warranty returns since system implementation.
- Eliminated operator fatigue and difficulties with manual visual access.

“A critical manual quality check was replaced by a fully automated system. Zero warranty claims have been received since implementation of the KITOV system”

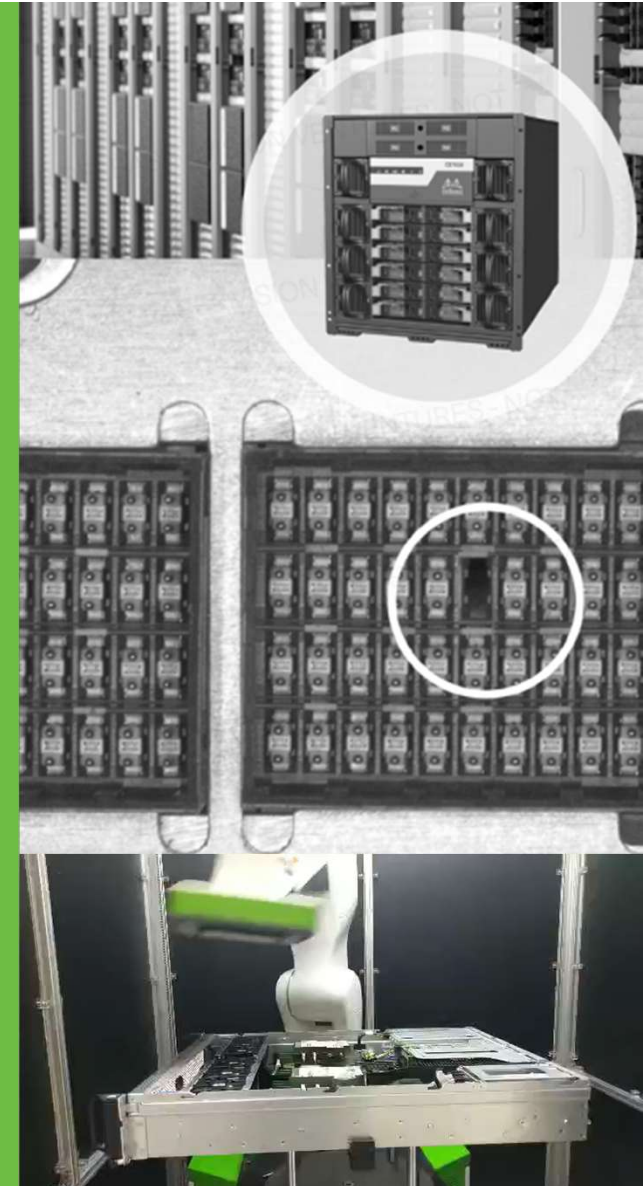

Case Study: solar^{edge}

Customer

- Customer: SolarEdge
- Sector: Smart Energy
- Global leader in smart energy technology and PV installations.
- Diversified portfolio including EV charging and grid services.
- Massive global scale with \$2Bn+ revenue and 4,900+ employees.

Application

- Comprehensive End-of-Line (EoL) assembly and wiring verification.
- Multi-point inspection of connectors, switches, glue points, and welding.
- Global rollout across facilities in the USA, China, Israel, and Europe.
- Flexible integration of stand-alone systems into existing production lines.

Impact

- Standardized quality and inspection protocols across all global sites.
- Significant improvement in accuracy compared to previous manual inspection.
- Realized shorter mean-time-to-repair (MTTR) and higher process visibility.



Case Study: AeroSpace Engine

Customer

- Customer: AeroSpace Engines
- Sector: Aerospace
- Tier-1 supplier of aerospace and defense engine technologies.
- Specialist in complex jet engine components and turbine discs.
- Publicly traded (TASE) with high-stringency quality requirements.

Application

- Robotic inspection of complex jet turbine discs with 600+ points / part.
- Advanced imaging of highly specular (shiny) and reflective metal surfaces.
- CAD-based definition of inspection areas for automated planning.
- Independent configuration of new part sizes for high-mix production.

Impact

- Reduced inspection time by 80%, from 1 hour down to 12 minutes.
- Maintained zero-tolerance quality standards for mission-critical parts.
- Enabled a continuous improvement process driven by AI algorithms.

“The KITOV Core+ reduced inspection time of complex discs by 80% from 1 hour to 12 minutes while providing the flexibility to simply change inspection plans for different part sizes”



 **KITOV.ai**

AI-Powered Quality Discovery



**WILLRICH PRECISION
I N S T R U M E N T**
THINK MEASUREMENT... THINK WILLRICH

Ph 866-945-5742 email:sales@willrich.com